

Sept. 29, 1953

L. H. DAVIDSON
CABINET HAVING IMPROVED MEANS FOR FACILITATING
OPENING DOORS SINGLY OR IN MULTIPLE
Filed May 3, 1947

2,653,851

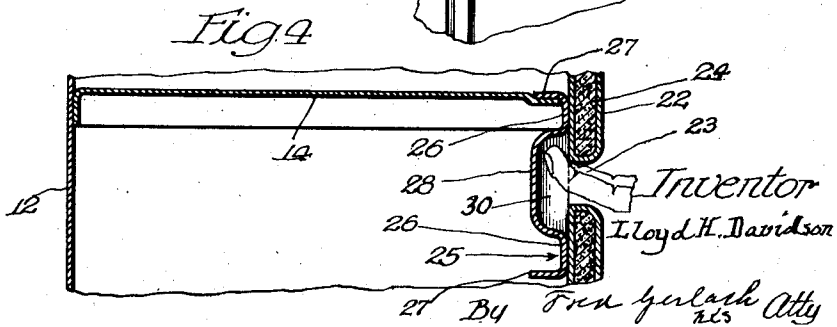
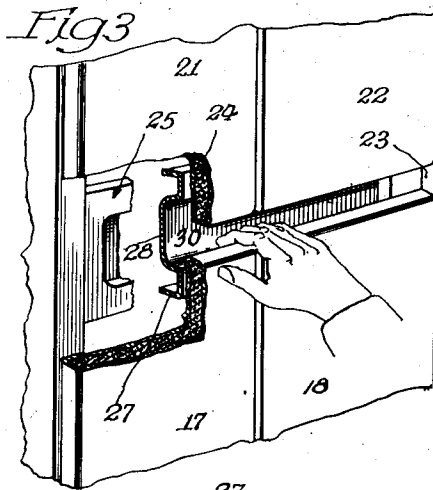
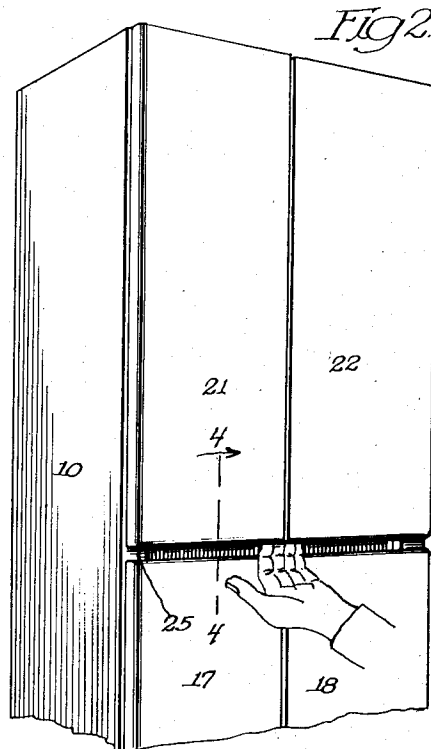
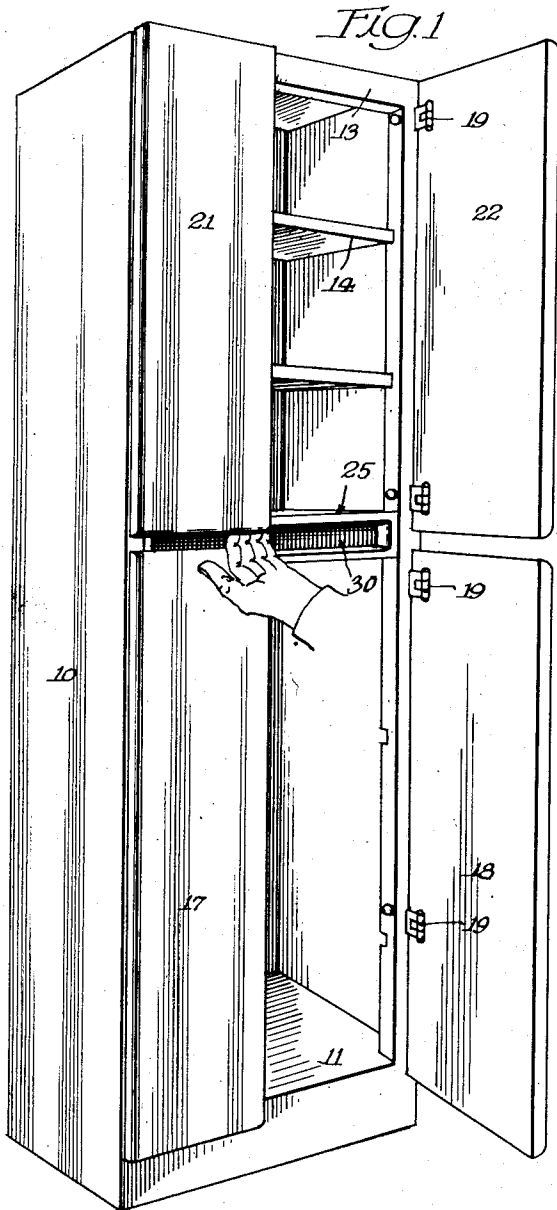

Inventor

Lloyd H. Davidson

By Fred Furlach Atty
265

UNITED STATES PATENT OFFICE

2,653,851

CABINET HAVING IMPROVED MEANS FOR FACILITATING OPENING DOORS SINGLY OR IN MULTIPLE

Lloyd H. Davidson, Connersville, Ind., assignor to Avco Manufacturing Corporation, New York, N. Y., a corporation of Delaware

Application May 3, 1947, Serial No. 745,810

5 Claims. (Cl. 312—320)

1

The invention relates to means for opening doors of cabinets, for access to the interior thereof.

In steel cabinets, such as are used for storage of various articles in kitchens, a desideratum is to provide door-opening means which eliminates projections such as handles or knobs, from the door or cabinet, and which is substantially invisible or maintains the neat and unobstructed appearance of the doors.

One object of the invention is to provide improved means for opening the doors of cabinets, which requires no handles or knobs on the doors, which is simple in construction, and whereby the doors may be opened singly or in multiple.

Another object of the invention is to provide door-opening means of this type which can be readily and inexpensively fabricated.

Other objects of the invention will appear from the detailed description.

The invention consists in the several novel features hereinafter set forth, and more particularly defined by claims at the conclusion hereof.

In the drawings:

Figure 1 is a perspective of a cabinet embodying the invention, the right-hand doors being shown in their open position.

Figure 2 is a perspective, the lower portion of the cabinet being broken away, both the upper and lower doors being shown in their closed position, and illustrating the manner of simultaneously opening the upper doors.

Figure 3 is a partial perspective, parts being shown in section, illustrating the manner of simultaneously opening the lower doors.

Figure 4 is a vertical section taken on line 4—4 of Figure 2.

The invention is exemplified in a cabinet which comprises a body including side walls 10, a bottom 11, a top wall 13, and a back wall 12. Shelves 14 are supported at desired elevations in the cabinet. The front of the cabinet is provided with a mating pair of lower doors 17 and 18, and an upper pair of mating doors 21 and 22. The body and doors are formed of sheet steel and the doors are of the double wall type with insulating material 36. All of these doors are pivotally supported adjacent the sides of the cabinet by spring hinges 19, which permit the doors to be swung laterally and outwardly on axes adjacent the sides of the cabinet and urge the doors to their closed position and preferably also to their open position after the doors are swung open to a predetermined degree. This results in smooth progress of the door opening

2

and closing operation, and in the doors being normally maintained in their closed position. The lower pair of doors 17, 18, and the upper pair of doors 21, 22, in their closed positions, terminate with contiguous vertical edges at the center of the front of the cabinet.

The lower edges of the upper doors 21, 22, are spaced vertically from the upper edges of the lower doors 17, 18, to provide a gap 23 between them, extending crosswise of the front of the cabinet, and of sufficient height for the insertion of fingers of a hand through gap. A bar 25 formed of sheet metal, has front face-portions 25, against which the back faces of the upper and lower doors are adapted to abut, respectively, and integral stiffening flanges 27 along their upper and lower edges. Between face-portions 26, bar 25 is provided with an indented portion 28 which forms a recess 30 in the back of gap 23 and overlaps the marginal portions of the inner faces of the lower margins of the upper doors and the inner faces of the upper margins of the lower doors. Recess 30 extends across the back faces of the doors at the joints between the contiguous inner side edges of the upper doors and the lower doors.

The construction described, provides means whereby the doors may be opened singly or in multiple. To open any of the doors, it is only necessary to insert a finger or fingers through the gap 23 and hook them around the margin of the door or doors to be opened. For example: if the upper doors 20, 21, are to be simultaneously opened for access to the interior of the upper portion of the cabinet, fingers of a hand may be inserted through gap 23 to simultaneously engage the inner lower corners of both doors, as illustrated in Fig. 2. If both of the lower doors are to be simultaneously opened for access to the interior of the lower portion of the cabinet, fingers may be inserted through gap 23 and hooked around the upper margin of the lower doors. The doors may be opened singly, by insertion of a finger or fingers, through gap 23, to engage the door to be opened. If it is desired to open the left-hand or right-hand doors, fingers may be inserted through the gap 23 to hook around the lower margin of the upper door and the upper margin of the lower door for the exertion of a pull on both. If it is desired to simultaneously open both of the upper and lower doors, the fingers of a hand may be inserted through the gap 23, into recess 30, with some of the fingers engaging the upper doors at their meeting edges and other fingers engaging the lower doors at

3

their meeting edges. The recess 30 in bar 25 serves as a guide for the fingers in engaging the doors and the spring hinges 19 normally urge the doors toward bar 25.

The invention exemplifies a cabinet with doors with means for conveniently opening the doors which eliminates any projections such as knobs or handles, from the front faces of the doors, is substantially imperceptible, or at least not readily recognizable as door-opening means, preserves a smooth, uninterrupted exterior appearance of the cabinet, and whereby the doors may be opened singly or in desired multiple. The bar 25 which is structural and fixed to the walls of the cabinet, provides the recess or channel in back of the edges of the doors adjacent their meeting edges, and the recess may be easily fabricated by deformation of a bar formed of sheet metal.

The invention is not to be understood as limited to the details described, since these may be modified within the scope of the appended claims without departing from the spirit or scope of the invention.

Having thus described the invention, what I claim as new and desire to secure by Letters Patent is:

1. A cabinet comprising walls, a pair of doors positioned one above the other, each door being hingedly attached at the side for opening and closing movements laterally, a fixed bar extending across the front of the cabinet behind the upper edge of the lower door and the lower edge of the upper door when the doors are in a closed position, said bar being provided with a centrally disposed finger-receiving recess extending horizontally between the respective doors and having upper and lower face portions defining said recess and extending forwardly into abutting relationship with inner faces of said doors at points above and below the lower and upper edges of the upper and lower doors respectively, when they are closed, said recess thereby vertically underlapping both the upper edge of said lower door and the lower edge of said upper door, said upper and lower extremities of said doors being vertically spaced apart for the entry of the fingers of the user into the recess of said bar and behind the doors whereby they may be opened singly or together.

2. A steel cabinet comprising side walls, mating pairs of doors disposed vertically of each other, each door being hinged to a wall to swing laterally about an axis adjacent its outer side edge, the inner edges remote from the walls being contiguous, the lower edges of the upper doors and the upper edges of the lower doors being spaced for the insertion of the user's fingers between them, and a fixed transverse bar extending across the front of the cabinet between the side walls, said bar having upper and lower face portions abutting the inner faces of said doors at points above and below the lower and upper edges of the upper and lower doors respectively, said bar also having a central recessed portion extending horizontally at least the width of a hand outwardly from each of said contiguous edges and underlapping the upper and lower extremities of said doors thereby providing a space for the entry of the fingers behind the upper or lower door edges whereby the doors may be opened singly or in multiple.

3. A cabinet comprising side walls, pairs of

4

doors disposed vertically of each other, each door being hingedly attached to a side wall for laterally swinging movements, the lower edges of the upper doors and the upper edges of the lower doors being spaced for the insertion of the user's fingers between them, and a fixed transverse bar extending across the front of the cabinet between the side walls in supporting relationship behind the inner faces of said doors at points above and below the lower and upper edges of the upper and lower doors respectively, said bar also having a central recessed portion extending horizontally behind and vertically underlapping said spaced lower edges of the upper doors and upper edges of the lower doors thereby providing a space for the entry of the user's fingers behind the upper and lower door edges whereby the doors may be opened singly or in multiple.

4. A cabinet comprising side, top, and bottom walls, a pair of doors positioned one above the other, each door being hingedly attached at the side for opening and closing movements laterally, a fixed bar extending across the front of the cabinet behind the upper edge of the lower door and the lower edge of the upper door when the doors are in closed position, said bar defining with the respective doors a vertically underlapping finger-receiving recess and having face portions supporting the inner faces of said doors at points above and below the lower and upper edges of the upper and lower doors respectively when they are closed, said upper and lower edges of said doors being vertically spaced apart for entry of the fingers of the user into the recess and behind the doors whereby they may be opened singly or together.

5. A cabinet comprising side, top, and bottom walls, a pair of doors hingedly attached to the side walls for opening and closing movements laterally, said doors having adjacent edges which are spaced slightly for entry of the user's fingers, a fixed bar extending across the face of the cabinet behind the adjacent edges when the doors are in closed position, said bar defining with the respective doors an underlapping finger-receiving recess and having face portions supporting the inner faces of said doors when they are closed, opening of said doors singly or together being accomplished by insertion of the user's fingers between the adjacent door edges and into the recess behind the inner faces of said doors.

LLOYD H. DAVIDSON.

References Cited in the file of this patent
UNITED STATES PATENTS

Number	Name	Date
214,213	Warner	Apr. 8, 1879
459,464	Tipton	Sept. 15, 1891
724,639	Wheeler	Apr. 7, 1903
1,079,507	McClerman	Nov. 25, 1913
1,264,816	Lanza	Apr. 30, 1918
1,668,595	McAuliffe	May 8, 1928
1,751,107	Smith	Mar. 13, 1930
1,846,713	Fanarjian	Feb. 23, 1932
1,908,831	Edward	May 16, 1933
2,137,165	Knight	Nov. 15, 1938
2,328,467	LaCasse	Aug. 31, 1943
2,332,761	Steiner	Oct. 26, 1943

FOREIGN PATENTS

Number	Country	Date
23,807	Denmark	Dec. 2, 1918