

(No Model.)

3 Sheets—Sheet 1.

P. W. RODECKER.
LEATHER PUNCHING MACHINE.

No. 488,324.

Patented Dec. 20, 1892.

Fig. 1

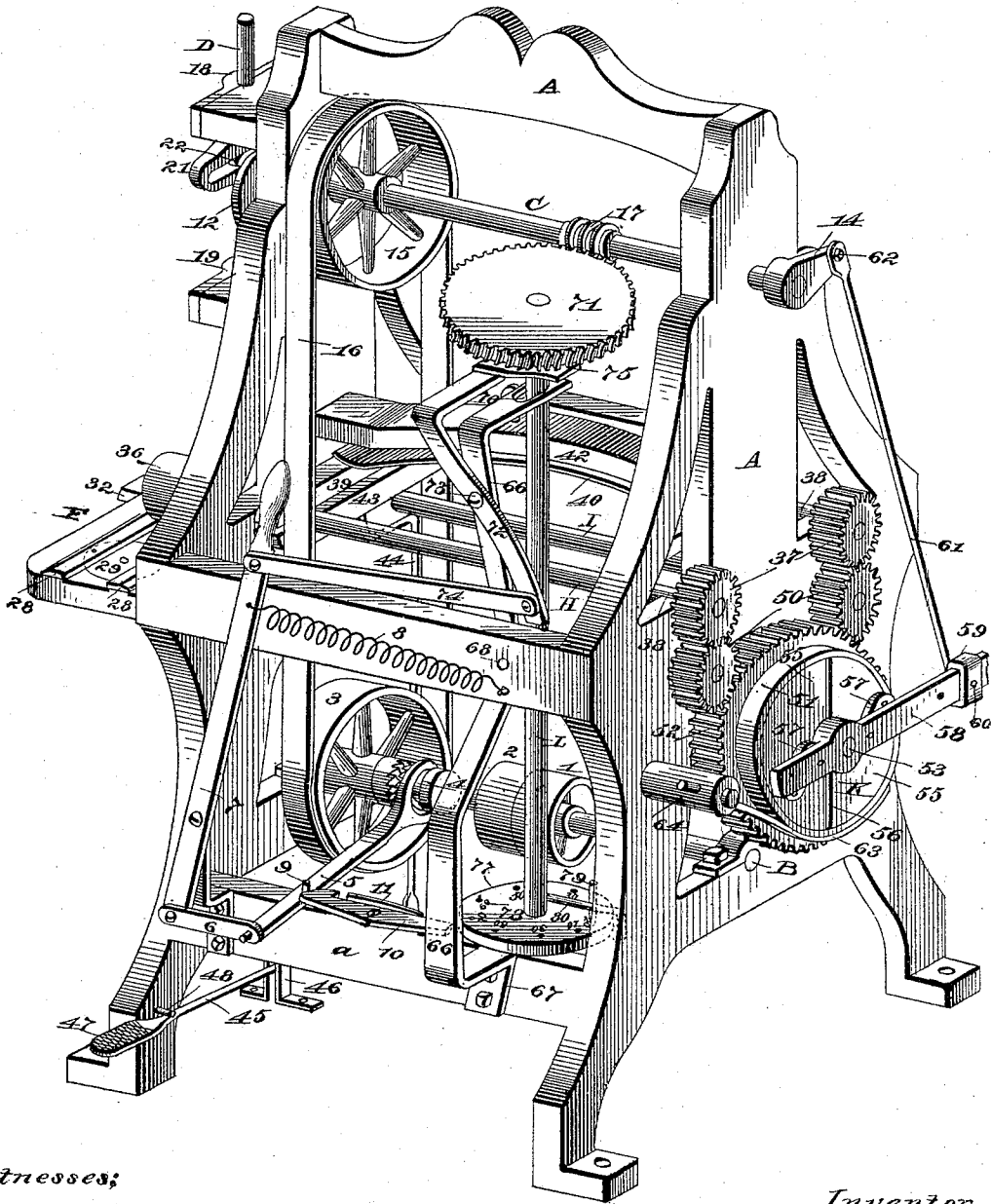

Witnesses;

J. F. Coleman
M. C. Massie

Inventor

Peter W. Rodecker,
By Wm Hunter Myers.

Att'y

(No Model.)

3 Sheets—Sheet 2.

P. W. RODECKER. LEATHER PUNCHING MACHINE.

No. 488,324.

Patented Dec. 20, 1892.

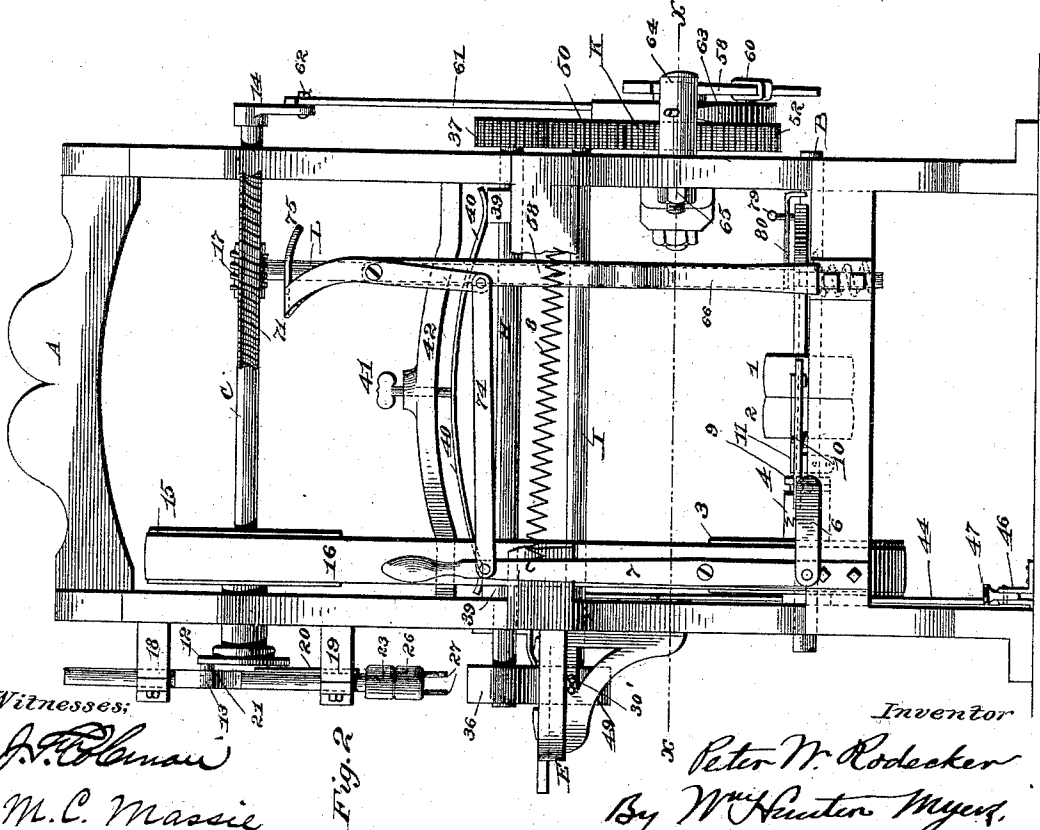
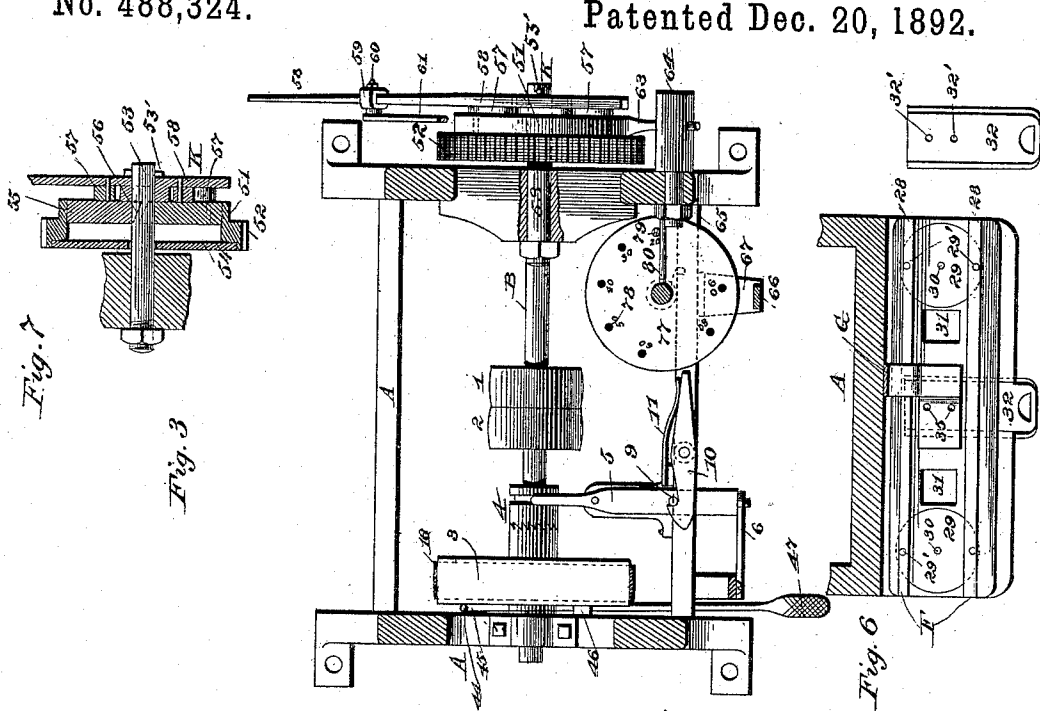

Witnesses:
J. F. Colman
M. C. Massie

Fig. 2

Inventor
Peter W. Rodecker
 By *Wm. Hunter Myers*

Att'y.

(No Model.)

3 Sheets—Sheet 3.

P. W. RODECKER.
LEATHER PUNCHING MACHINE.

No. 488,324.

Patented Dec. 20, 1892.

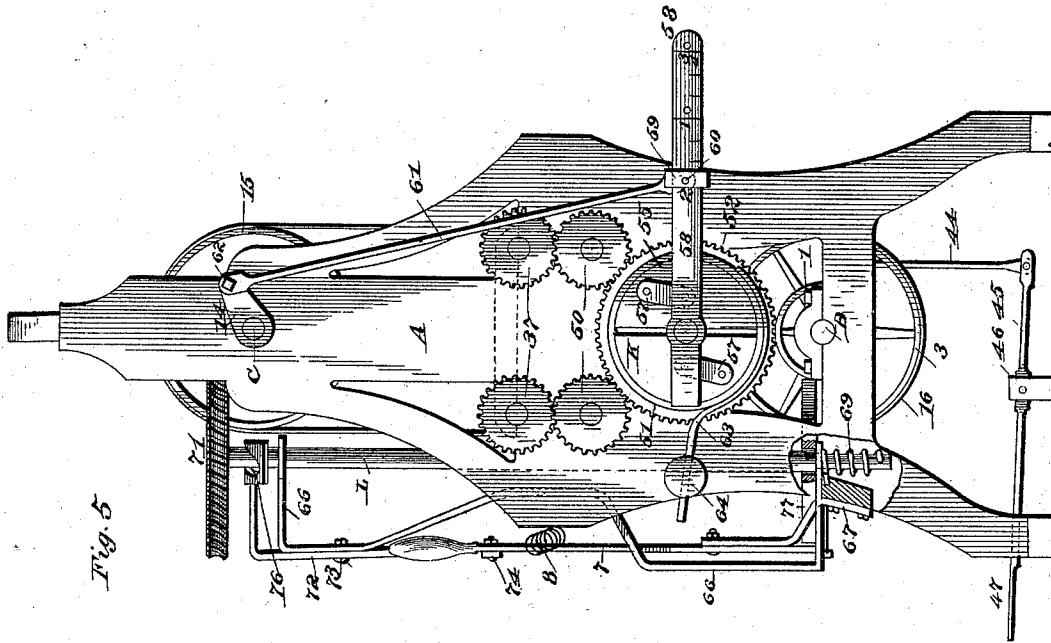

Fig. 5

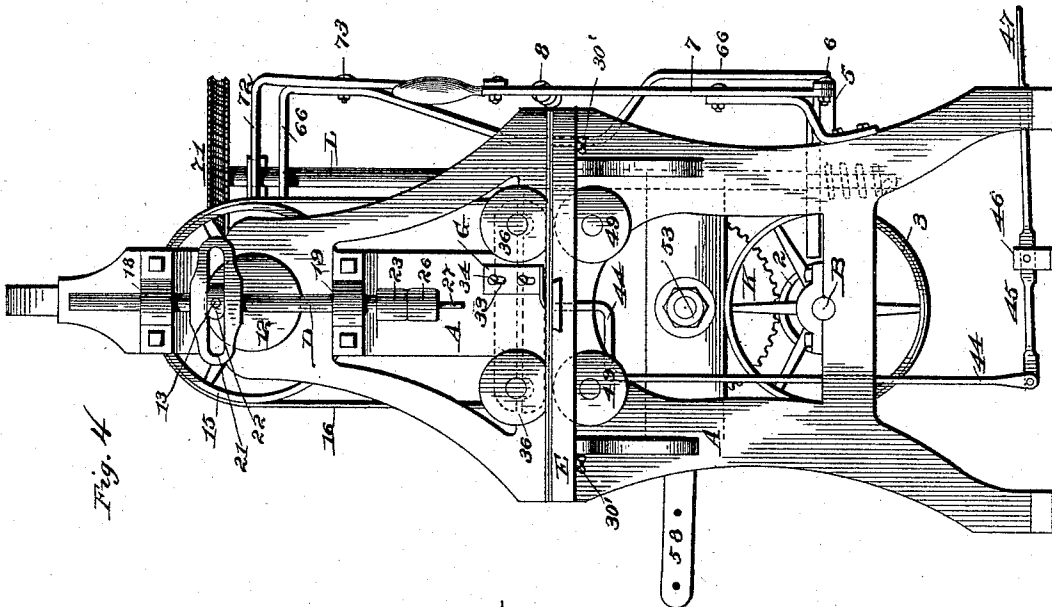

Fig. 4

Witnesses:

J. F. Coleman
M. C. Massie

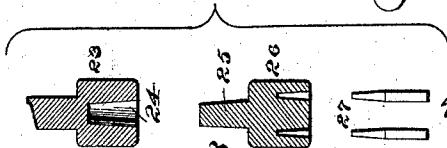

Fig. 8

Inventor
Peter W. Rodecker
By *Wm. Hunter Myers*

Att'y.

UNITED STATES PATENT OFFICE.

PETER W. RODECKER, OF SIDNEY, OHIO, ASSIGNOR OF ONE-HALF TO CHARLES E. GIVEN, JOSEPH C. ROYON, AND JOHN F. GIVEN, OF SAME PLACE.

LEATHER-PUNCHING MACHINE.

SPECIFICATION forming part of Letters Patent No. 488,324, dated December 20, 1892.

Application filed May 16, 1892. Serial No. 433,195. (No model.)

To all whom it may concern:

Be it known that I, PETER W. RODECKER, a citizen of the United States of America, residing at Sidney, in the county of Shelby and State of Ohio, have invented certain new and useful Improvements in Leather-Punching Machines, of which the following is a specification, reference being had therein to the accompanying drawings.

My invention relates to a leather-punching machine of that class in which holes of any desired size and distance apart may be automatically punched in straps of various widths or thicknesses, and whose operation will be automatically stopped when the strap is punched, to permit the removal of the finished strap and the introduction of another to be operated upon, such a machine being peculiarly adapted to the manufacture of fly-nets for horses.

My invention will first be described in connection with the accompanying drawings and then more particularly pointed out in the claims.

Figure 1 is a perspective view of my invention. Fig. 2 is a side elevation. Fig. 3 is a horizontal sectional view taken on the line $x-x$, Fig. 2, showing the friction gear-wheel in elevation. Fig. 4 is a front elevation. Fig. 5 is a rear elevation. Fig. 6 is a detailed plan view of the work-shelf and its attached mechanisms, showing, also, a detached die. Fig. 7 is a central sectional view of the friction gear-wheel and its attached mechanism, with the shaft in elevation. Fig. 8 is a sectional view of the boss, the punch-chuck, and the punches.

In the drawings, A is the framework, in which is mounted the operating mechanism of the machine.

B is the power-shaft, journaled at each end in the framework, and having a tight pulley 1 and a loose pulley 2 near its center. At its front end is the lower band wheel 3, revolvable upon it, and capable of being coupled to said shaft by a clutch 4, operated by clutch-lever 5 through the medium of a link 6 and hand-lever 7. Clutch 4 is held out of connection with band-wheel 3 by a spring 8, attached to the upper end of lever 7 and to the frame

A, and is retained in connection against the pressure of spring 8 by means of a detent-pin 9 in the clutch-lever 5 engaging with a detent 10, pivoted to a cross-beam a of the frame A, and actuated by a spring 11 secured to the side of said beam.

Journaled in the upper portion of the frame is a punch-operating shaft C, parallel to the power-shaft B, and projecting beyond the frame A at each end. To its front end is fixed the crank-disk 12, having a crank-pin 13 in its face, and to its rear end is fixed the crank 14. Near the front end of shaft C, just inside the frame A, is fixed a band-wheel 15, connected with the lower band-wheel 3 by a belt 16. Upon shaft C, between band-wheel 15 and the rear part of frame A, is fixed a worm-gear 17.

To the front of frame A are bolted two keepers, 19 and 10, forming guides for a punch-bar D, provided with a feather 20, which engages with a groove in the lower keeper 19 for the purpose of preventing rotation of said bar. For the purpose of reciprocation, the punch-bar is provided with a yoke 21 carrying a journal-box 22, in which works the crank-pin 13 of the disk 12. On the lower end of punch-bar D is fixed a boss 23, having a socket 24, (Fig. 8) for the reception of the stem 25 of a chuck 26, in such manner that the chuck will be frictionally held to the boss. The chuck is recessed in its lower end for the reception of punches 27, which are frictionally held therein. It is apparent that I may use chucks having recesses closer together or farther apart, as may be desired, and may also use punches of different sizes.

E is a work-shelf secured to the front of the machine, on which is mounted an adjustable guide F, which consists of two parallel bars 28, extending longitudinally of the shelf, and two disks 29, each bearing two pins 29' near its periphery, which engage with the bars 28, the disks 29 being located in recesses in the shelf in such manner that their top surfaces will lie flush with the top of the shelf. It is apparent that, by this construction, when the disks are revolved in one direction or the other, the bars 28 will be moved closer together or farther apart. The disks

are also provided with pins 30, which pass downward through the shelf and are screw-threaded on their lower ends for the reception of thumb-nuts 30' for holding the guide-bars in adjusted position. In the shelf are two openings 31, the purpose of which will be described hereinafter. In a dove-tailed groove transversely of the shelf is placed a removable die 32, punch-holes or recesses, 32', in which are so located as to register with the punches.

To the front of the machine, just above the shelf, is a spring presser-foot G, slotted as at 33 for adjustable attachment to frame A by means of screws 34, the presser-foot having perforations, as 35, designed to be in register with the punches.

H are upper feed-roll shafts, which carry on their front ends feed-rolls 36 and on their rear ends gear-pinions 37. These shafts are journaled at each end in open bearings 38 in the frame A, being retained in these bearings by yokes 39, riding upon them and pressed down by a spring 40, the pressure of which may be adjusted by means of a thumb-screw 41 passing through a screw-threaded bolt-hole in a longitudinal brace 42 of frame A.

Beneath the upper feed-roll shafts H, near their front ends, is a lifting-yoke 43, supported at its center by a lifting-rod 44, which is pivoted at its lower end to one end of a foot-lever 45, fulcrumed to the floor at 46, and having a foot-plate 47 at its other end. The downward movement of the lifting-yoke is limited by a pin 48 fixed in frame A above the outer end of the lever. By pressing down the foot-lever the upper feed-rolls 36 may be raised for the purpose of inserting under them a strap to be punched.

I are lower feed-roll shafts, journaled in the frame A, and having on their front ends lower feed-rolls 49 and on their rear ends gear-pinions 50. Feed-rolls 49 project up through the openings 31 in shelf E, their upper surfaces being flush with the top of the shelf and normally in contact with the upper feed-rolls 36. The upper feed-rolls are removably attached to shafts H, to permit the use of rolls of various widths corresponding to the widths of straps to be punched.

At the rear of the machine is a friction gear-wheel K, having a smooth friction-surface 51 and a geared surface 52, of larger diameter, meshing with both gear-pinions 50, which latter mesh with gear-pinions 37 directly above them, as clearly shown in Fig. 5. Friction-wheel K is revoluble upon a stud 53, fixed to the machine, which passes through a hole in a central web 54 and through an opening in an interior circular expanding center 55. This expanding center comprises two semi-circular halves, overlapping each other along their contiguous diameters, their overlapping edges 56 being scarfed for this purpose, as shown in Fig. 7. To each half is pivoted one end of a link 57, the other ends of said links being pivoted to a lever 58 rotatable on the

fixed stud 53. These links 57, in connection with the lever 58, form compound toggles, which, on the upward movement of said lever, crowd the halves of the expanding center away from each other and into frictional contact with the interior surface of the friction gear-wheel K. The downward movement of the lever reverses this action. The expanding center 55 is retained in place within the friction gear-wheel K by the lever 58, held against it by a pin 53', passing through the stud 53, as shown in Fig. 7. On the long end of lever 58 is a clip 59, adjustable thereon by means of a pin 60 passing through it and through one of a series of holes in the lever 58. To the clip is pivoted the lower end of a connecting-rod 61, the upper end of which is attached to crank 14 on the shaft C by a wrist-pin 62. Lever 58 is provided with several holes at varying distances from the fulcrum, each hole being indicated by a contiguous number, denoting the number of inches of leather that will be fed by the feed-rolls at each revolution of the machine when the clip 59 is fastened to the lever 58 at that point by the pin 60.

63 is a segmental friction-spring pressing on the smooth friction-surface 51 of geared friction-wheel K, and serving to prevent said wheel from being turned forward by its own momentum after the expanding center has released it. One end of this friction-spring is fixed in a stud 64, adjustably attached to the frame A by means of a thread and nut 65, as shown in Fig. 2. By loosening the nut the stud can be turned so as to put any desired pressure of the spring upon the friction-wheel K, and by then tightening the nut it will be held in this position.

L is a vertical revoluble finger-shaft, whose lower end, of reduced diameter, is stepped loosely in a bent upright support 66, rigidly attached to the frame A at 67 and 68. The reduced end of shaft L projects through a hole in this support of smaller diameter than the main portion of the shaft, and has a spring 69 coiled around it, one end of said spring being attached to the shaft and the other end fastened to the frame A. The upper end of shaft L projects through a transverse slot 70 in the upper end of support 66, and has a worm-wheel 71 fixed upon it, adapted to engage with the worm-gear 17 on the shaft C.

72 is a bent cam-lever, pivoted to the support 66 at 73, and having its lower end pivotally attached to one end of a link 74, the other end of which is pivotally attached to the hand-lever 7. At the upper end of the cam-lever 72 is secured a segmental cam-plate 75, having a curved cam-slot 76, through which the shaft L passes. By means of this slotted cam-plate the worm-wheel 71 on the upper end of the shaft L may be thrown into or out of engagement with the worm-gear 17 on the shaft C through the medium of hand-lever 7, link 74, and cam-lever 72.

Just above the point where the shaft L is

stepped in the lower end of support 66 is a dial 77, fixed upon the frame A, and having a central hole, through which shaft L passes. In this dial are holes 78, at graduated distances apart, for the reception of a stop-pin 79. Each hole has a contiguous number, the use of which will be explained hereinafter.

On shaft L, just above the dial 77, is fixed a finger 80, projecting at right angles to the shaft, and having its outer end bent downward, as is clearly shown in Fig. 2.

Power is transmitted to the power shaft B by a belt from the main line-shaft. (Not shown.)

15 The operation of my machine is as follows: The upper feed-rolls 36 are raised by pressing down the foot-lever, which raises the lifting-rod 44 and with it the lifting-yoke 43. The strap to be punched is inserted in the guide
20 between the upper and lower feed-rolls, and the point at which the first holes are to be punched is placed directly beneath the spring presser-foot. The hand-lever is drawn forward, which causes worm-wheel 71 to engage with worm-gear 17 and also throws the clutch 4 into gear with the band-wheel 3, in
25 which position it is held by the detent 10 engaging the pin 9 on the clutch-lever 5. Now if it is desired to punch, say, twenty sets of
30 holes in the strap, the pin 79 is set in the hole in the dial indicated by the number 20, the finger 80 being in front of the said pin. The revolution of the upper shaft C forces the punch down, punching the first
35 holes in the strap. The continued revolution withdraws the punch, and as soon as it is above the presser-foot the lever 58 at the rear of the machine is drawn upward, expanding the central portion of the frictional gear-wheel
40 K and turning the latter partially around, thereby revolving the gear-pinions, and with them the feed-rolls, feeding the strap along to where it is again required to be punched. This distance is regulated in advance by the
45 position of the clip 59 on the lever 58. The continued revolution of the shaft C forces the lever down, releasing the expanding center, and permitting the gear-wheel K and feed-pinions and rolls to remain stationary. The
50 punch again descends and punches another set of holes, and the operation is continued as before. At each revolution of the shaft C the worm-gear 17 revolves the worm-wheel 71 one tooth, and with it the shaft L, carrying
55 the finger 80 around until, after a certain number of revolutions of the shaft C, the finger strikes the detent 10, forcing it out of engagement with the pin 9 on clutch-lever 5 and permitting the spring 8 to throw the
60 clutch open, stopping the machine and disengaging the worm-wheel 71 from the worm-gear 17. As soon as this happens the spring 69 at the bottom of the shaft L unwinds, revolving the shaft in a direction opposite to
65 that imparted to it by the worm-gear 17, thereby carrying the finger 80 back against the pin 79 in the dial 77, which stops it. As the

number of revolutions which the upper shaft C must make to bring the finger into contact with the detent, and thereby stop the ma-
70 chine, is determined by the distance the finger has to travel over the dial from the pin to the detent, it will be readily seen that the position of the pin in the dial will regulate the number of times the strap will be punched
75 before the machine is stopped. As the dial is graduated and has holes for the pin at each graduation, the number of holes for each strap can be regulated in advance. As soon as the machine is stopped by release of the detent
80 10 the strap is removed, and a new one inserted as before, and the operation repeated as heretofore described.

Having thus fully described my invention, what I claim as new and desire to secure by
85 Letters Patent, is—

1. In a leather-punching machine, a reciprocating punch-bar carrying a punch, mechanism for operating the same, a finger actuated by the punch-bar-operating mechanism, a
90 dial over which the finger travels, a stop-pin inserted in the dial and against which the finger normally rests, and punch-bar-stopping mechanism actuated by the finger for stopping the punch-bar after it has made a pre-
95 determined number of reciprocations governed by the position of the stop-pin in the dial.

2. In a leather-punching machine, a power shaft, a band-wheel loose thereon, a clutch
100 mechanism normally locking said band-wheel to the shaft, a punch, a punch-operating shaft deriving motion from said band-wheel, and pre-adjustable automatic clutch releasing mechanism for disengaging the clutch
105 from the band-wheel after a predetermined and variable number of revolutions of the punch-operating shaft.

3. In a leather-punching machine, a power-
110 shaft, a band-wheel loose thereon, a clutch mechanism normally locking said wheel to the shaft, a punch a punch-operating shaft deriving motion from said band-wheel, a spring-actuated clutch-lever engaging with the clutch and provided with a detent-pin,
115 a detent adapted to engage with said pin, and trip mechanism for automatically releasing said detent from the detent-pin after a predetermined number of revolutions of the punch-operating shaft, whereby the clutch
120 is thrown out of engagement with said band-wheel.

4. In a leather-punching machine, a power-
125 shaft, a punch a punch-operating shaft deriving motion from the power-shaft, a shaft perpendicular to the punch-operating shaft and deriving motion therefrom, and pre-adjustable stop mechanism actuated by the perpendicular shaft for automatically stopping the punch-operating shaft after it has made
130 a predetermined number of revolutions.

5. In a leather-punching machine, a power-
shaft, a band-wheel loose thereon, a clutch mechanism normally locking the band-wheel

to the shaft, a spring-actuated clutch-lever engaging with the clutch and provided with a detent-pin, a detent adapted to engage with said pin, a punch a punch-operating shaft deriving motion from said band-wheel, a finger-shaft driven by the punch-operating shaft, and a finger mounted thereon and adapted to release the detent from the detent-pin after a predetermined number of revolutions of the punch operating shaft, whereby the clutch is thrown out of engagement with the band-wheel.

6. In a leather-punching machine, a power-shaft, a band-wheel loose thereon, a clutch mechanism normally locking the wheel to said shaft, a punch a punch-operating shaft deriving motion from said band-wheel, a worm-gear on the punch-operating shaft, a worm-wheel shaft, a worm-wheel thereon adapted to engage with the worm-gear, mechanism operated by the worm-wheel shaft for automatically releasing the clutch from the band-wheel, and a lever adapted to simultaneously engage the clutch with the band-wheel and the worm-wheel with the worm-gear.

7. In a leather-punching machine, a power-shaft, a punch a punch-operating shaft deriving motion from the power shaft, a worm-gear on the punch-operating shaft, an oscillating finger-shaft carrying a finger and provided with a worm-wheel adapted to engage with the worm-gear, and mechanism actuated by the finger for stopping the punch-operating shaft after it has made a predetermined number of revolutions and simultaneously oscillating the finger-shaft to disengage the worm-wheel from the worm-gear.

8. In a leather-punching machine, a power-shaft, a punch a punch-operating shaft deriving motion from the power shaft, a finger-shaft driven by the punch-operating shaft, automatic mechanism actuated by the finger-shaft for stopping the punch-operating shaft after it has made a predetermined number of revolutions, and means for automatically rotating the finger-shaft back to its normal position.

9. In a leather-punching machine, a power-shaft, a punch a punch-operating shaft deriving motion therefrom, a finger-shaft driven by the punch-operating shaft, a finger mounted thereon, a dial over which the finger travels, a stop-pin inserted in the dial and against which the finger normally rests, and mechanism actuated by the finger for stopping the punch-operating shaft after it has moved the finger a predetermined distance from the stop-pin.

10. In a leather-punching machine, a power-shaft, a punch a punch-operating shaft deriving motion from the power shaft, a finger-shaft driven by the punch-operating shaft, a finger mounted thereon, a dial over which the finger travels, having a series of holes, a stop-pin insertible in any given hole in the dial and against which the finger normally rests,

and mechanism actuated by the finger for stopping the punch-operating shaft after it has made a number of revolutions predetermined by the position of the stop-pin in the dial.

11. In a leather-punching machine, a power-shaft, a punch a punch-operating shaft deriving motion from the power shaft, a finger-shaft driven by the punch-operating shaft, a finger mounted thereon, a dial over which the finger travels, a stop-pin inserted in the dial and against which the finger normally rests, mechanism actuated by the finger for stopping the punch-operating shaft after it has moved the finger a predetermined distance from the stop-pin, and means for revolving the finger back over the dial to its normal position against the stop-pin.

12. In a leather-punching machine, a power-shaft, a punch a punch-operating shaft deriving motion from the power shaft, a worm-gear on the punch-operating shaft, a finger-shaft, a worm-wheel thereon normally in engagement with said worm-gear, a stationary dial having a series of holes and contiguous numbers, a finger mounted on the finger-shaft and adapted to travel over the dial, a stop-pin insertible in any given hole in the dial and against which the finger normally rests, and mechanism actuated by the finger for simultaneously stopping the punch-operating shaft and disengaging the worm-wheel from the worm-gear after the punch-operating shaft has made a number of revolutions predetermined by the position of the stop-pin in the dial and indicated by the number opposite the stop-pin.

13. In a leather-punching machine, a power-shaft, a punch a punch-operating shaft deriving motion from the power shaft, a worm-gear on the punch-operating shaft, a finger-shaft, a worm-wheel thereon normally in engagement with the worm-gear, a stationary dial having a series of holes and contiguous numbers, a finger mounted on the finger-shaft and adapted to travel over the dial, a stop-pin insertible in any desired hole in the dial and against which the finger normally rests, mechanism actuated by the finger for simultaneously stopping the punch-operating shaft and disengaging the worm-wheel from the worm-gear after the said shaft has made a given number of revolutions predetermined by the position of the stop-pin in the dial and indicated by the number opposite the stop-pin, and means for revolving the finger-shaft backward until the finger is brought into its normal position against the stop-pin.

14. In a leather-punching machine, a power-shaft, a band-wheel loose thereon, a clutch mechanism normally locking the band-wheel to said shaft, a clutch-lever engaging the clutch and provided with a detent-pin, a detent normally in engagement with said pin, a spring-actuated hand-lever connected to the clutch-lever, a punch a punch-operating shaft deriving motion from the said band-wheel, a worm-

gear on the punch-operating shaft, a finger-shaft, a worm-wheel thereon normally in engagement with said worm-gear, a stationary dial through which the punch-operating shaft loosely passes, a stop-pin inserted in the dial, a finger carried by the finger-shaft, adapted to travel over the dial and disengage the detent from the detent-pin, thereby permitting the clutch-lever to release the clutch from the band-wheel after the punch-operating shaft has made a number of revolutions predetermined by the position of the pin in the dial, means for disengaging the worm-wheel from the worm-gear, and a spring for rotating the finger-shaft backward until the finger is brought into its normal position against the stop-pin.

15. In a leather-punching machine, a power-shaft, a band-wheel loose thereon, a clutch mechanism normally locking said wheel to the shaft, a clutch-lever in engagement with the clutch and carrying a detent-pin, a spring-held hand-lever connected to the clutch-lever, a spring-pressed detent, normally in engagement with the detent-pin, a punch a punch-operating shaft deriving motion from the band-wheel on the power-shaft, a worm-gear on the punch-operating shaft, an oscillating finger-shaft carrying a finger for releasing the detent and provided with a worm-wheel normally in engagement with said worm-gear, a cam-lever provided with a slotted cam-plate, through which the finger-shaft passes, said cam-lever being pivotally connected with the hand-lever, a dial having a series of holes and numbers contiguous thereto, a stop-pin adapted to be inserted in any given hole in the dial for limiting the backward movement of the finger, and a spring for rotating the finger-shaft backward, by which mechanisms the punch-operating shaft will be automatically stopped after a given number of revolutions predetermined by the position of the stop-pin in the dial and indicated by the contiguous number, the worm-wheel will be disengaged from the worm-gear, and the finger-shaft will be rotated backward until the finger reaches its normal position.

16. In a leather-punching machine, feed-roll shafts carrying feed-rolls and gear-wheels, a driving gear-wheel in mesh with the latter and having an interior friction-surface, an expanding center inside of said friction-surface, and means for expanding said center into frictional contact with the friction-surface, imparting a rotary motion to said center, and then contracting the latter out of contact with said friction-surface.

17. In a leather-punching machine, feed-roll shafts carrying feed-rolls and gear-wheels, a driving gear-wheel in mesh with the latter and having an interior annular friction-surface, a sectional expanding center within the annular portion of the driving gear-wheel, a link pivoted to each section, a lever to which said

links are pivoted, a punch, a punch-operating shaft, means for operating the same, and connections between said shaft and lever for giving the latter an oscillating movement, whereby in one movement of the lever the center will be expanded into contact with the friction-surface of the driving gear-wheel and impart motion to said wheel, and in the opposite movement of the lever the center will be contracted, permitting the wheel to remain at rest.

18. In a leather-punching machine, feed-roll shafts carrying feed-rolls and gear-wheels, a driving gear-wheel in mesh with the latter and having an interior annular friction-surface, a sectional expanding center within the annular portion of the driving gear-wheel, a link pivoted to each section, a lever to which said links are pivoted, a clip adjustable on the lever, a punch a punch-operating shaft provided with a crank, means for operating said shaft, and a rod connecting said crank and clip, whereby an adjustable intermittent revolution is imparted to the feed-rolls.

19. In a leather-punching machine, the combination, with the frame, a work-shelf attached thereto, and open journal-bearings in the frame, of a pair of feed-roll shafts mounted in said bearings and carrying feed-rolls which operate above the shelf, means for driving said shafts, a lifting-yoke beneath one end of the shafts, pressure-yokes bearing on the shafts, a tension-spring bearing on the pressure-yokes, a foot-lever, and a rod connecting said lever and the lifting-yoke, whereby the feed-rolls may be lifted out of their normal position, for the purpose stated.

20. In a leather-punching machine, the combination, with the frame, a work-shelf attached thereto, having an opening near each end, and open journal-bearings in the frame, of a pair of upper feed-roll shafts mounted in said bearings and carrying feed-rolls which operate over the openings in the shelf, a pair of lower feed-roll shafts journaled in the frame and carrying feed-rolls which operate in openings in the shelf, means for driving both pairs of shafts, a lifting-yoke beneath one end of the upper shafts, pressure-yokes bearing on the upper shafts, pressure-yokes bearing on the pressure-yokes, a foot-lever, and a rod connecting said lever and the lifting-yoke, for the purposes stated.

21. In a leather-punching machine, the combination, with the frame and a work-shelf attached thereto, of an adjustable work-guide comprising two parallel bars, a series of disks located in recesses in the shelf and pivoted to the bars, and means for holding the disks in position.

In testimony whereof I affix my signature in presence of two witnesses.

PETER W. RODECKER.

Witnesses:

J. C. ROYON,
A. J. HESS.