

June 25, 1935.

G. CHARVET

2,006,262

MECHANISM FOR ANGULAR ADJUSTMENT OF GUN SIGHTS

Filed July 13, 1931

3 Sheets-Sheet 1

Fig. 1

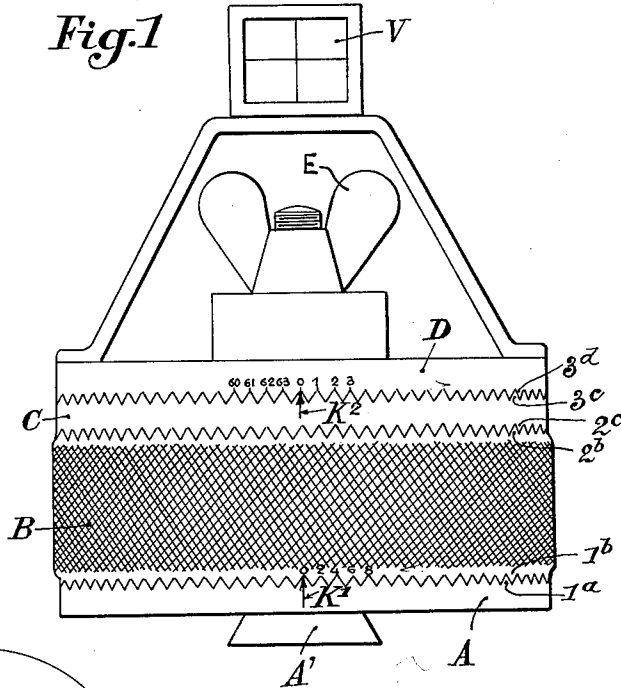

Fig. 7.

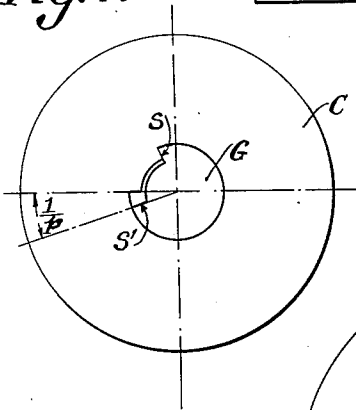
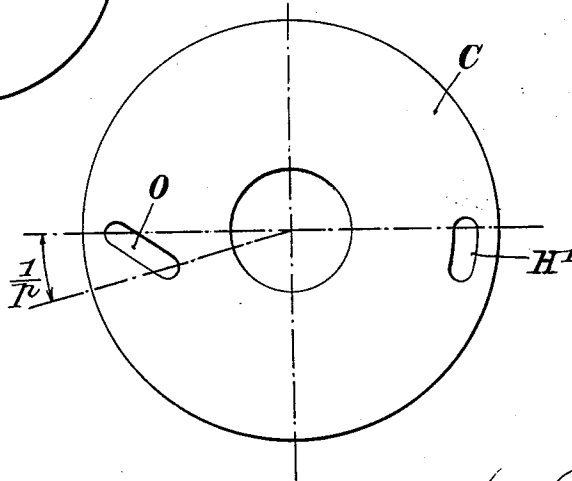

Fig. 4



G. Charvet
INVENTOR

By: *Marks & Clerk*
ATTYS.

1412
~~7419~~

72

59

June 25, 1935.

G. CHARVET

2,006,262

MECHANISM FOR ANGULAR ADJUSTMENT OF GUN SIGHTS

Filed July 13, 1931

3 Sheets-Sheet 2

Fig. 2

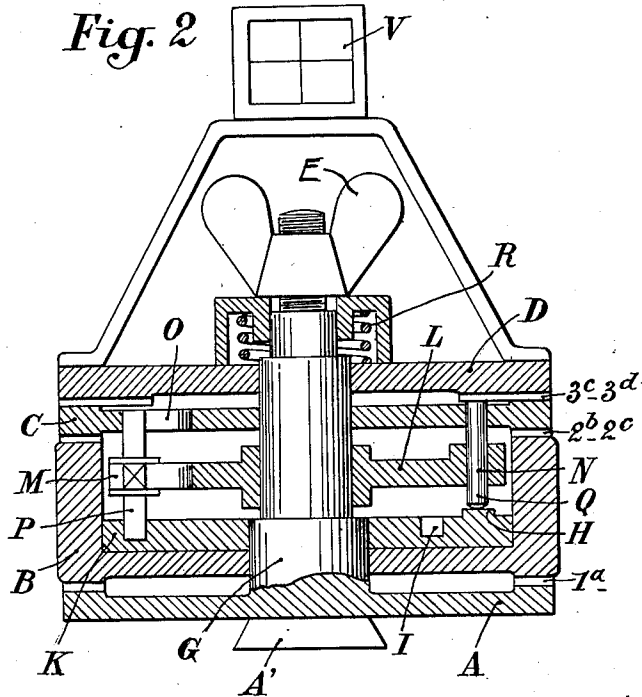
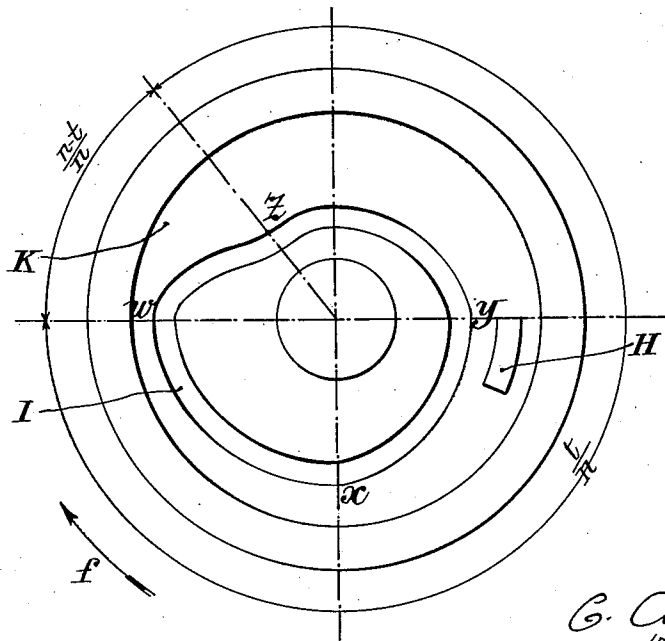

Fig. 3



G. Charvet
INVENTOR

By: *Maxwell H. Clark*
ATTYS.

June 25, 1935.

G. CHARVET

2,006,262

MECHANISM FOR ANGULAR ADJUSTMENT OF GUN SIGHTS

Filed July 13, 1931

3 Sheets-Sheet 3

Fig. 5

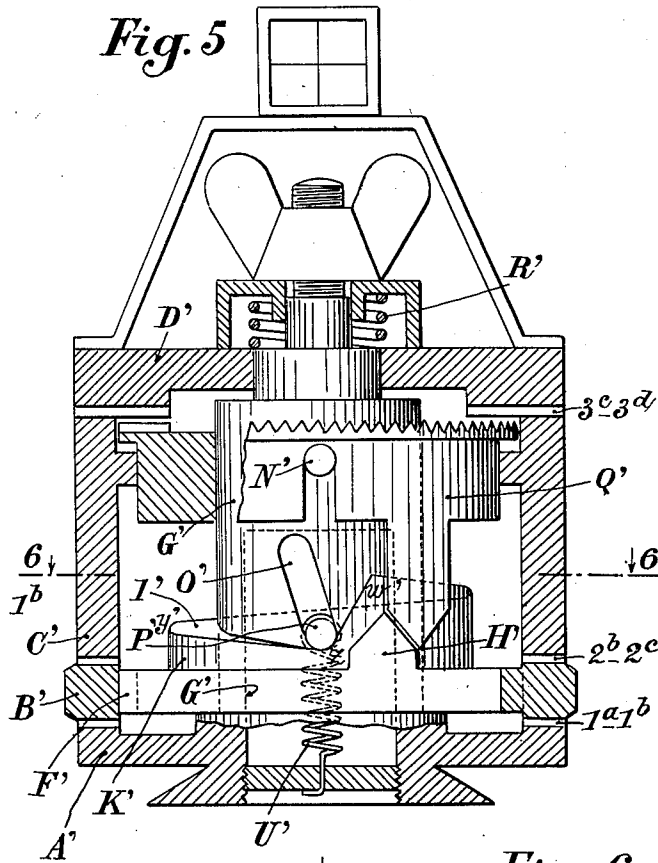
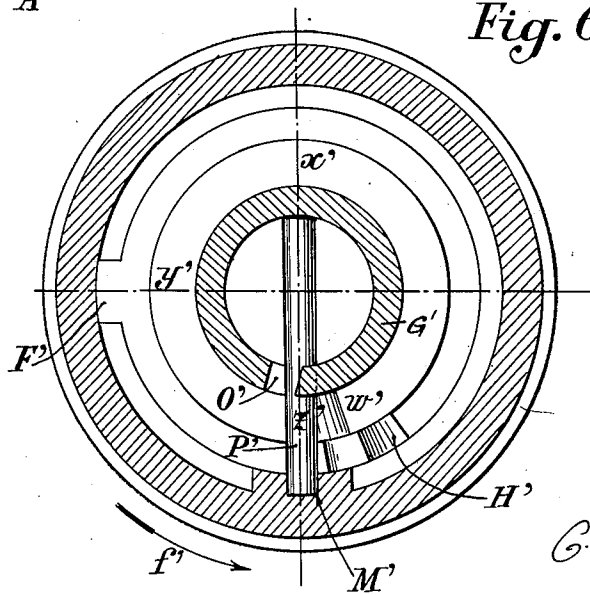

Fig. 6



G. Charvet
 INVENTOR
 By: Market Clerk
 ATTYS.

Patented June 25, 1935

2,006,262

UNITED STATES PATENT OFFICE

2,006,262

MECHANISM FOR ANGULAR ADJUSTMENT OF GUN SIGHTS

Gustave Charvet, Paris, France, assignor, by mesne assignments, to Anciens Etablissements Barbier, Benard & Turenne, Paris, France, a French Company

Application July 13, 1931, Serial No. 550,598
 In France July 21, 1930

3 Claims. (Cl. 33-59)

The present invention relates to improvements in or modifications to mechanisms for angular adjustments, more particularly adapted for goniometric sighting instruments for firearms, claimed in my Patent No. 1,939,540 of December 12, 1933, comprising a stationary disk and a movable disk each provided with a row of teeth, at least one connecting or intermediary disk provided with two rows of teeth, each row of each disk being adapted to be disconnectably coupled with a row of said connecting disk, all said disks being angularly movable with respect to one another, the spacing of the teeth of at least two tooth couplings bearing a known relation to but differing from each other.

According to the invention, one of said connecting, or intermediate disk, is connected with the movable disk, on the one hand by one of the aforesaid teeth couplings, and on the other hand by connecting means so arranged that, when said intermediate disk is rotated in one direction with reference to the stationary disk through an angle corresponding to a certain number of teeth of the coupling between the stationary disk and the intermediate disk, said movable disk will turn in the contrary direction with reference to the first mentioned rotation of said intermediate disk, and by an equal number of teeth of the coupling connecting these two last-mentioned disks.

Further characteristics of the invention will be set forth in the following description.

In the accompanying drawings, which are given by way of example:

Fig. 1 is an elevational view of an embodiment of the invention.

Fig. 2 is a vertical diametral section of the device shown in Fig. 1.

Fig. 3 is a plan view of the lower slotted disk.

Fig. 4 is a plan view of the upper slotted disk.

Fig. 5 is a vertical diametral section of another embodiment of the invention.

Fig. 6 is a horizontal section on the line 6-6 of Figure 5.

Fig. 7 is a plan view of an embodiment of the invention, the upper disk being removed.

The device for angular adjustments comprises, in the same manner as the apparatus described in my above mentioned Patent 1,939,540, four superimposed disks A, B, C, D (Fig. 1) mounted on an axle G and engaging each other by toothings with different numbers of teeth, the disk A being for instance stationary and the disk D carrying the device V which is to be adjusted in angular positions. These disks are urged against

each other by the spring R and may be clamped in their adjusted position by the nut E. If the number of teeth 1^a and 1^b between the disks A and B is n , the number of teeth 2^b and 2^c between the disks B and C is m , and the number of teeth 3^c and 3^d between the disks C and D is p , it has been explained in the above patent that, when it is desired to change the angular position of disk D with relation to disk A through a desired determined angle, disk D is first turned with reference to the other disks, so as to record said desired determined angle with the approximation of

$$\frac{1}{p}$$

revolution.

In order to turn disk D further through the angle corresponding to the difference between said desired determined angle and the angle already recorded by the disk D, disk B is turned with reference to stationary disk A through an angle corresponding to a number S of teeth 1^a and then disk C is turned on the contrary direction with reference to disk B by the same number S of teeth 2^b .

The invention has essentially for its object to dispense with this double operation and to avoid the resulting risk of error. It is based upon the fact that the angle

$$\frac{m-n}{m \times n}$$

revolution is by hypothesis a fraction of the angle

$$\frac{1}{p}$$

revolution (since it is desired to obtain an approximation greater than

$$\frac{1}{p}$$

revolution), so that disk C, by the said double rotation, will never turn through an angle greater than

$$\frac{1}{p}$$

revolution.

On the other hand, the number of teeth S by which the tothing 1^b is turned with reference to the tothing 1^a must be equal to the number of teeth through which the tothing 2^c has turned with reference to the tothing 2^b ; in other words, when the tothing 1^b advances by one tooth with

reference to the tothing 1^a, the tothing 2^c of disk C should advance by one tooth with reference to the tothing 2^b of disk B. In order that any given tooth of the tothing 2^c shall drop into the next recess of the tothing 2^b, the tothing 2^c must advance relatively to the tothing 2^b by an angle greater than

$$\frac{1}{2m}$$

revolution, which angle corresponds to half the length of a tooth of the tothing 2^c. Now, the amount of rotation of disk B, in order that a tooth of the tothing 1^b shall advance by one tooth with reference to the tothing 1^a, is

$$\frac{1}{n}$$

revolution.

According to one embodiment of the invention shown in Figure 7, the rotation of disk C is limited (for instance by stops *s* and *s'* on the stationary spindle G) to

$$\frac{1}{p}$$

revolution, (the maximum rotation, as above stated), whereby when disk B is turned through one tooth 1^a or through an angle of

$$\frac{1}{n}$$

revolution, disk C which is driven by disk B turns only through an angle of

$$\frac{1}{p}$$

revolution (*p* is greater than *n* and

smaller than

$$\left(\frac{1}{n}\right)$$

so that the action is the same as if C had turned with relation to B of

$$\left(\frac{1}{n} - \frac{1}{p}\right)$$

revolution, and as stated above, this angle must be greater than

$$\frac{1}{2m}$$

revolution in order that disk C advances by one tooth 2^b when disk B advances by one tooth 1^a.

According to another embodiment of the invention (Figs. 2, 3 and 4), the rotation of disk C is controlled within the angle of

$$\frac{1}{p}$$

revolution in an automatic manner, and independently of the motion which is imparted thereto by the couplings 2^b and 2^c, according as disk B rotates relatively to disk A, in such manner that, irrespectively of the amount of rotation of disk B with reference to disk A, disk C will constantly assume substantially the desired position relatively to disk B, and will rotate, with reference to the latter, by a number of teeth *S* (equal to the number of teeth by which disk B has turned with reference to disk A).

As shown in Figures 2 to 4, disk B is secured

to a member K, having a slot I consisting of two spiral arcs *wxyz* and *zw* (Fig. 3) which are connected together at the ends. A member L is keyed to stationary spindle G, above member K, and carries a radial slot M. In disk C is cut a slot O of suitable shape and direction, the angular distance between its two ends with reference to the centre of the disk being equal to

$$\frac{1}{p}$$

revolution. A member P is caused to follow simultaneously slots I, M and O. When disk B is turned through an angle corresponding to the arc *wxyz*, the member P moves along the slot I, is guided radially by the slot M and travels from one end to the other of slot O. If there are *t* teeth 1^b on the portion of disk B corresponding to arc *wxyz*, there will be *n-t* teeth on the portion of disk B corresponding to arc *zw*.

When disk B is turned by one tooth of tothing 1^b (that is by

$$\frac{1}{n}$$

revolution with reference to disk A) in the direction of the arrow *f* (Figure 3), member P, controlled by slot I, moves along this latter and also along slot M by a fraction

$$\frac{1}{t}$$

of its whole stroke. The disk C, driven by disk B, is allowed by member P and slot O to turn only

$$\frac{1}{pt}$$

revolution, so that the action is the same as if C had turned with relation to B of

$$\left(\frac{1}{n} - \frac{1}{pt}\right)$$

revolution. If *m*, *n*, *p* and *t* are so chosen that

$$\frac{1}{n} - \frac{1}{pt} = \frac{1}{m}$$

or

$$\frac{1}{pt} = \frac{m-n}{m \times n}$$

it will be obvious that when the tothing 1^b advances by one tooth with reference to the tothing 1^a, the tothing 2^c of disk C will advance by one tooth with reference to the tothing 2^b of disk B.

In this manner, the double operation of disks B and C is replaced by a single operation of disk B.

In the conditions above explained, when *t* teeth of disk B have ridden over the teeth of disk A, disk C will have turned through

$$\frac{1}{p}$$

revolution, and member P has reached the end of slot O. In order to still increase the angle between the disks D and A, in the proper direction, disk D must be advanced by one tooth relatively to disk C, and disk C must then be returned to zero, after which disk B can be again turned in order to move the same number of teeth of the tothing 1^b and 2^c with reference to the tothings 1^a and 2^b, respectively.

In order to avoid this complicated operation, the device for the positive control of disk C is

preferably so constructed that said disk will be automatically returned to zero without having to turn disk B rearwardly, the return motion of disk C to zero taking place concurrently with that of disk B, by continuing to rotate this latter in the same direction. In these conditions, under the positive control of member P and slots I, M and O, the disk C will gradually advance through

$$\frac{1}{p}$$

revolution when disk B is turned through the angle corresponding to arc $wxyz$, and it then moves back by

$$\frac{1}{p}$$

revolution when disk B is turned through an angle corresponding to arc zw .

If the disks C and D would remain constantly engaged by their teeth 3^c and 3^d , these two successive reverse movements of disk C would be imparted to disk D; but if the disposition is such that, at the beginning of the back stroke of disk C, disk D is uncoupled from disk C and is locked with respect to the stationary plate A, the disk C will now move back by one tooth of the p -toothed coupling 3^c relatively to the tothing 3^d of disk D. Disk D being then re-engaged with disk C at the end of the back movement of the latter, disk D will have been automatically advanced by one tooth with reference to the corresponding p -toothed coupling of disk C, thus providing for a continuous control.

In the embodiment shown in Figures 2 to 4, this result is obtained in the following manner:

Disk K comprises one or more bosses H, whose effective length is less than

$$\frac{n-t}{n}$$

of the circumference; member L has as many holes N, parallel with spindle G as there are bosses H, and disk C has one or more slots H^1 , of the same length as the boss or bosses H. In the hole (or holes) N is slidable a member Q having at its upper part one or more teeth; when member Q is raised by the corresponding boss H, its teeth engage the teeth of disk D, which are extended for this purpose towards the spindle G.

The operation is as follows:

If, starting from zero, t teeth of the tothing 1^b (as above stated) have been moved over the stationary disk A, member P proceeds into the second part zw of the spiral slot I, then returning to its initial position during the travel of the $(n-t)$ teeth which remain to be moved in order to make a complete revolution. By the action of slot O, member P also returns disk C to its initial position, whereby disk C moves back through

$$\frac{1}{p}$$

revolution corresponding to one tooth of disk D.

At the beginning of this return motion, member Q is raised by boss H and slides in its hole N, so that its teeth engage the teeth of disk D, and raise the said disk and hold it against rotation. Boss H then moves away, thus allowing member Q and disk D to move down under the action of spring R, at the end of the return movement of disk C, and before the n^{th} tooth of the tothing 1^b of disk B has moved beyond the pointer K^1 of disk A. Thus, the teeth of disk

D are again engaged with the teeth of disk C, but disk D has advanced by one tooth with reference to disk C. After disk B has returned to zero, its rotation can be continued, and each complete rotation will advance disk D by one tooth that is by

$$\frac{1}{p}$$

revolution.

Figs. 5 and 6 show another embodiment of the invention. A member K' , rotatable on a stationary spindle G' , is locked in rotation with disk B' by means of a key F' . The top face I' of member K' has the shape of two helical arcs $w' x' y' z'$ and $z' w'$, which are connected together at the ends; in the same way as arcs $w x y z$ of Fig. 3, arc $w' x' y' z'$ corresponds to a fraction

$$\frac{t}{n}$$

of a circumference, and arc $z' w'$ correspond to a fraction

$$\frac{(n-t)}{n}$$

of a circumference. Member K' carries at the periphery one or more bosses H' .

A key P' , suitably guided so as to move in a direction parallel with its axis, is urged by a spring U' into constant contact with the helical surface of member K' ; said key is also movable in a slot O' , having the shape of a helical arc, cut in the stationary spindle G' (whose lower part is recessed as shown at G''); thus when member K' is rotated by disk B', key P' will move up and down along slot O' , while rotating with reference to stationary spindle G' .

The pitch of the helical slot O' is such that for a complete up or down stroke, key P' will turn through

$$\frac{1}{p}$$

of a revolution about spindle G' .

The end of key P' engages a straight slot M' cut along a generatrix of disk C' (Figure 6), so as to rotate disk C' through

$$\frac{1}{p}$$

of a revolution as a maximum, without however imparting to it the up and down movement of key P' .

A member Q' , whose upper face is toothed upon a part or the whole of its periphery, is adapted to engage the teeth of disk D', which are extended for the purpose; member P' may be raised or lowered by the boss or bosses H' , without rotating, by means of one or more guiding studs N' carried by spindle G' .

The operation is as follows:

When disk B' is turned by one tooth of the tothing 1^b , that is, through

$$\frac{1}{n}$$

of a revolution, with reference to disk A', in the direction of arrow f' (Fig. 6), member P' , controlled by the helical cam surface of member K' will rise through a fraction

$$\frac{1}{t}$$

of its stroke, but as it is guided by the slot O', it will also rotate through the fraction

$$\frac{1}{pt}$$

of a revolution,

$$\frac{1}{pt}$$

being equal to

$$\frac{m-n}{m \times n},$$

and the m -toothed coupling 2^c of disk C' will advance by one tooth with reference to the m -toothed coupling 2^b of disk B'.

Thus the double operation of disks B' and C' is replaced by a single operation of disk B'.

Furthermore, when, starting from the zero position, member B' has been moved by t teeth, key P' engages the second part $z'w'$ of the helical cam surface I' of member K', and during the travel of the $n-t$ teeth which remain to make a complete revolution, key P' returns to its initial position, and by means of the slots O' and M', it returns disk C' to its initial position; otherwise stated, during this movement, disk C' moves back by

$$\frac{1}{p}$$

of a revolution, corresponding to one tooth of disk D'.

At the beginning of this return stroke, member Q', impelled by boss H', rises without turning, due to the slot N', and its teeth engage the teeth of disk D', which is raised and held against rotation. Boss H' then moves away, thus allowing member Q' and disk D' to move down, under the action of spring R', at the end of the return movement of disk C', before the n^{th} tooth of the toothing I^b of disk B' has moved beyond pointer K'.

In this manner, the teeth of disk D' again engage the teeth of disk C', but disk D' has advanced by one tooth with reference to the teeth of disk C'.

The operator may thus continue to rotate disk B', now returned to zero, and each complete revolution of the latter will advance disk D' by one tooth, that is by a fraction

$$\frac{1}{p}$$

of a revolution.

Obviously, the invention is not limited to the embodiments herein described and represented, these being given solely by way of example; for example, the shapes of the slots O, O' and M, M' may be inverted. Slot O' may be formed either in the spindle G' (Fig. 3) or in a member secured to the same. The arrangements for the positive control and for the uncoupling of disk D may be of a different type.

A number of devices according to the invention may be connected together, either upon the same axis or upon different axes, in order to adjust angles in different planes (for azimuths and elevations).

Having now described my invention, what I claim as new and desire to secure by Letters Patent is:

1. In a mechanism for angular adjustment, more particularly adapted for goniometric sight-

ing instruments for firearms, the combination of a stationary member, a movable member provided with a slot, and an intermediate member, said members being provided with coupling teeth for selective interconnection with one another, the number of teeth in one tooth coupling differing from the number of teeth in the other tooth coupling, a cam operatively connected with said intermediate member, a guiding member fixed with respect to said stationary member, and a stop member engaging said cam, said guiding member and said slot in said movable member, said guiding member and said slot having such an inclination with relation to each other that when said intermediate member is advanced with reference to the stationary member by one tooth of the coupling between the stationary member and the intermediate member, said intermediate member will also be advanced with reference to said movable member by one tooth of the coupling between said intermediate and said movable members.

2. In a mechanism for angular adjustment, more particularly adapted for goniometric sighting instruments for firearms, the combination of a stationary member, an intermediate member abutting against said stationary member, a movable member provided with a slot abutting against said intermediate member and a plate abutting against said movable member, said members and plate being provided with inter-engaging coupling teeth for selective connection with one another, the number of teeth in one tooth coupling differing from the number of teeth in the other tooth coupling, and said intermediate member, movable member and plate being rotatably mounted above a common axis, spring means urging yieldingly said members and plate towards each other, a cam fixed to said intermediate member, a guiding member fixed with respect to said stationary member, and a stop member engaging said cam, said guiding member and said slot in said movable member, said cam having such a shape that when said intermediate member is rotated through a complete revolution, said stop member and said movable member are displaced along two strokes of the same amplitude, but in opposite directions, and said guiding member and said slot having such an inclination with relation to each other that when said intermediate member is advanced with reference to the stationary member by one tooth of the coupling between the stationary member and the intermediate member during one of said two strokes, said intermediate member will also be advanced with reference to said movable member by one tooth of the coupling between said intermediate and said movable members, a push piece adapted to separate said plate from said movable member against the action of said spring means, and a second cam operatively connected with said intermediate member and adapted to cooperate with said push-piece when said intermediate member is advanced during the other of said strokes so as to separate said plate from said movable member only during a rotation of said movable member relative to said plate member equal to a tooth spacing between said movable and plate member.

3. A mechanism for angular adjustment more particularly adapted for goniometric sighting instruments for firearms, comprising a stationary member, an intermediate member abutting against said stationary member, a movable mem-

59

2,006,262

5

ber abutting against said intermediate member and a plate member abutting against said movable member, all said members being rotatable about a common axis and provided with inter-
5 engaging circular rows of coupling teeth for selective angular connection with one another, the number of teeth in one tooth coupling differing from the number of teeth in another tooth coupling, resilient means adapted to hold said discs
10 in adjusted position and to allow relative rotation for a new adjustment, a guiding member fixed with respect to said stationary member, there being a slot in said guiding member, a slot in said movable member and a cam slot in said intermediate member, a connecting rod extending through said slots, a push piece adapted to cooperate with said plate member, means
5 for carrying said push piece in an angularly fixed position with respect to said stationary member, at least one boss upon said intermediate member for displacing axially said push piece against said resilient means in order to
10 release the coupling between said plate and movable members during the return stroke of the latter.

GUSTAVE CHARVET.