

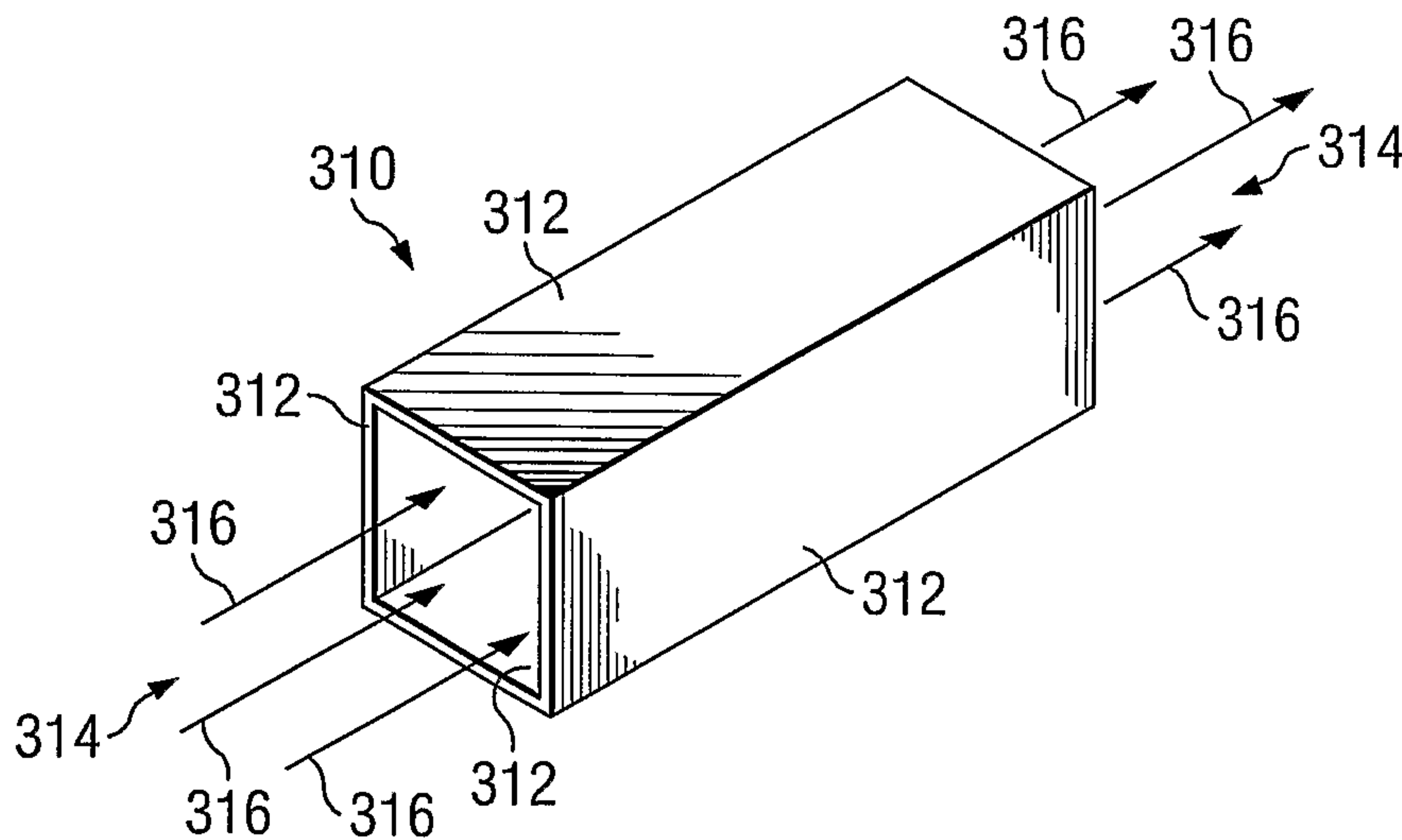

(86) Date de dépôt PCT/PCT Filing Date: 2004/09/30  
 (87) Date publication PCT/PCT Publication Date: 2005/04/14  
 (85) Entrée phase nationale/National Entry: 2006/03/15  
 (86) N° demande PCT/PCT Application No.: US 2004/032129  
 (87) N° publication PCT/PCT Publication No.: 2005/033633  
 (30) Priorité/Priority: 2003/10/01 (US60/507,720)

(51) Cl.Int./Int.Cl. *G01F 1/64* (2006.01),  
*E21B 49/08* (2006.01)  
 (71) Demandeur/Applicant:  
REM SCIENTIFIC ENTERPRISES, INC., US  
 (72) Inventeur/Inventor:  
MAUTE, ROBERT E., US  
 (74) Agent: KIRBY EADES GALE BAKER

(54) Titre : APPAREIL ET PROCEDE POUR MESURER L'ECOULEMENT DE FLUIDES AVEC ECRAN DE DETECTEUR  
 (54) Title: APPARATUS AND METHOD FOR FLUID FLOW MEASUREMENT WITH SENSOR SHIELDING



(57) **Abrégé/Abstract:**

Methods and apparatuses for detecting radial flows of conductive fluid are provided. In an embodiment of the present invention, shields are used to prevent or reduce circulating electrical currents from causing a voltage difference that would adversely affect the measured voltage difference between two adjacent electrodes. The shields may be a conduit through which conductive fluid may flow. Groups of sensors, e.g., two or more, may be placed within the shield. The shields may have any cross-section shape. Generally, once the circulating electrical current flow between the electrode pairs is substantially reduced or eliminated, only the voltage difference from the localized induced electric field remains. This way, a true induced voltage may be measured, and thus an accurate value for the fluid velocity may be determined.

(12) INTERNATIONAL APPLICATION PUBLISHED UNDER THE PATENT COOPERATION TREATY (PCT)

(19) World Intellectual Property  
Organization  
International Bureau



(43) International Publication Date  
14 April 2005 (14.04.2005)

PCT

(10) International Publication Number  
**WO 2005/033633 A2**

- (51) International Patent Classification<sup>7</sup>: **G01F**
- (74) Agent: **KNAPP, Roger C.?**; Slater & Matsil, L.L.P., 17950 Preston Rd., Suite 1000, Dallas, Texas 75252 (US).
- (21) International Application Number: PCT/US2004/032129
- (81) Designated States (unless otherwise indicated, for every kind of national protection available): AE, AG, AL, AM, AT, AU, AZ, BA, BB, BG, BR, BW, BY, BZ, CA, CH, CN, CO, CR, CU, CZ, DE, DK, DM, DZ, EC, EE, EG, ES, FI, GB, GD, GE, GH, GM, HR, HU, ID, IL, IN, IS, JP, KE, KG, KP, KR, KZ, LC, LK, LR, LS, LT, LU, LV, MA, MD, MG, MK, MN, MW, MX, MZ, NA, NI, NO, NZ, OM, PG, PH, PL, PT, RO, RU, SC, SD, SE, SG, SK, SL, SY, TJ, TM, TN, TR, TT, TZ, UA, UG, US, UZ, VC, VN, YU, ZA, ZM, ZW.
- (22) International Filing Date: 30 September 2004 (30.09.2004)
- (25) Filing Language: English
- (26) Publication Language: English
- (30) Priority Data: 60/507,720 1 October 2003 (01.10.2003) US
- (71) Applicant (for all designated States except US): **REM SCIENTIFIC ENTERPRISES, INC.** [US/US]; 1213 Chesterton Drive, Richardson, Texas 75080 (US).
- (84) Designated States (unless otherwise indicated, for every kind of regional protection available): ARIPO (BW, GH, GM, KE, LS, MW, MZ, NA, SD, SL, SZ, TZ, UG, ZM, ZW), Eurasian (AM, AZ, BY, KG, KZ, MD, RU, TJ, TM), European (AT, BE, BG, CH, CY, CZ, DE, DK, EE, ES, FI, FR, GB, GR, HU, IE, IT, LU, MC, NL, PL, PT, RO, SE, SI, SK, TR), OAPI (BF, BJ, CF, CG, CI, CM, GA, GN, GQ, GW, ML, MR, NE, SN, TD, TG).
- (72) Inventor; and
- (75) Inventor/Applicant (for US only): **MAUTE, Robert E.** [US/US]; 1213 Chesterton Drive, Richardson, Texas 75080 (US).

[Continued on next page]

(54) Title: APPARATUS AND METHOD FOR FLUID FLOW MEASUREMENT WITH SENSOR SHIELDING

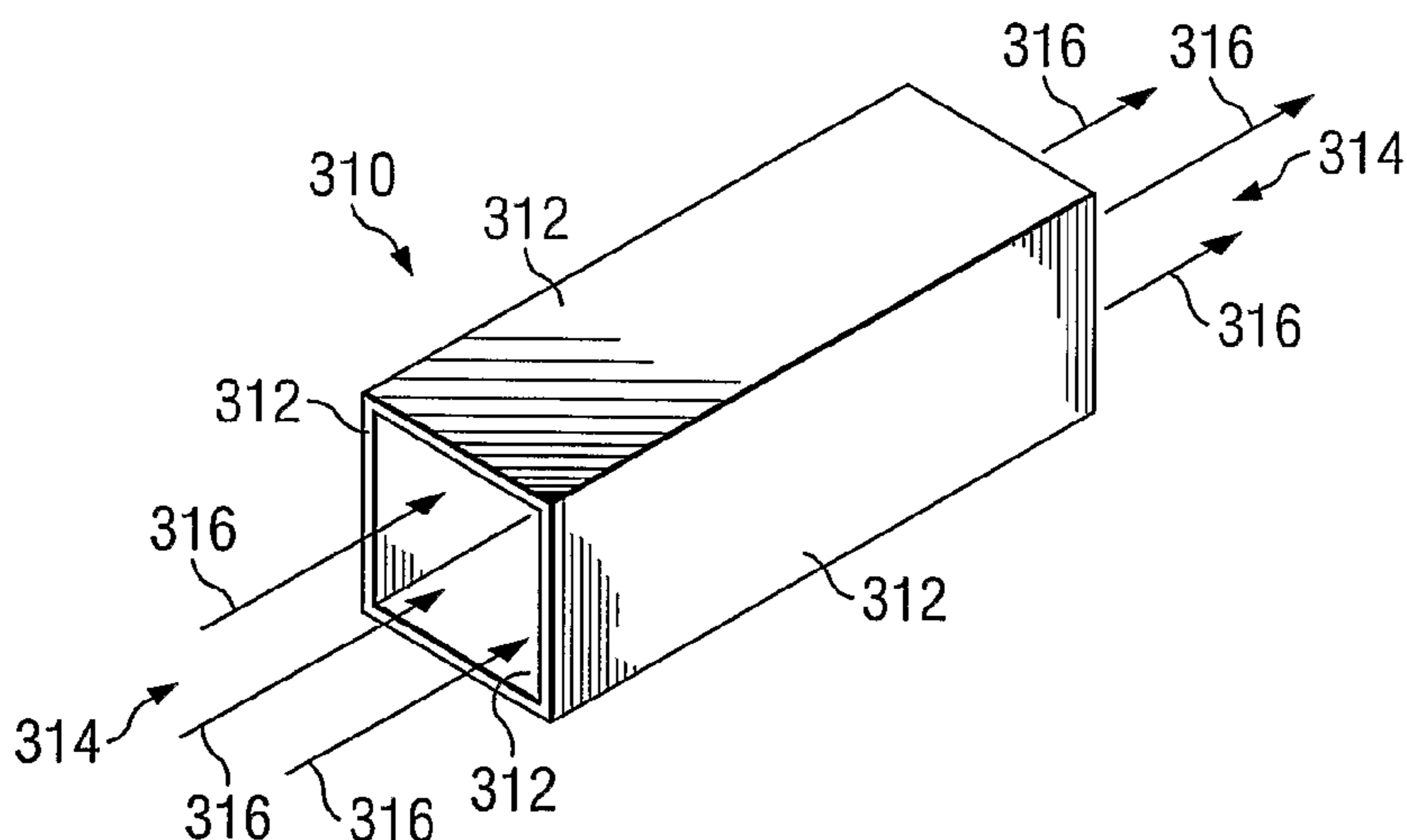

(57) Abstract: Methods and apparatuses for detecting radial flows of conductive fluid are provided. In an embodiment of the present invention, shields are used to prevent or reduce circulating electrical currents from causing a voltage difference that would adversely affect the measured voltage difference between two adjacent electrodes. The shields may be a conduit through which conductive fluid may flow. Groups of sensors, e.g., two or more, may be placed within the shield. The shields may have any cross-section shape. Generally, once the circulating electrical current flow between the electrode pairs is substantially reduced or eliminated, only the voltage difference from the localized induced electric field remains. This way, a true induced voltage may be measured, and thus an accurate value for the fluid velocity may be determined.

WO 2005/033633 A2

**WO 2005/033633 A2**



**Declaration under Rule 4.17:**

— *of inventorship (Rule 4.17(iv)) for US only*

**Published:**

— *without international search report and to be republished upon receipt of that report*

*For two-letter codes and other abbreviations, refer to the "Guidance Notes on Codes and Abbreviations" appearing at the beginning of each regular issue of the PCT Gazette.*

### Apparatus and Method for Fluid Flow Measurement with Sensor Shielding

This application claims the benefit of U.S. Provisional Application No. 60/507,720, filed on October 1, 2003, entitled "Apparatus and Method for Fluid Flow Measurement with Sensor Shielding," which application is hereby incorporated herein by reference.

#### CROSS-REFERENCE TO RELATED APPLICATIONS

5           This application is related to the following co-pending and commonly-assigned patent applications: Serial No. 09/880,402, filed June 13, 2001, entitled "Conductive Fluid Logging Sensor and Method," now issued as U.S. Patent No. 6,711,947 B2; Serial No. 10/600,053, filed June 20, 2003, entitled "Fluid Flow Measuring Device and Method of Manufacturing Thereof," now issued as U.S. Patent No. 6,799,407 B2; and Serial No. 10/924,320, filed August 23, 2004, entitled "Fluid Flow Measuring Device and Method of Manufacturing Thereof," which  
10 applications/patents are hereby incorporated herein by reference.

#### TECHNICAL FIELD

This invention relates generally to fluid flow sensing devices and methods and, more particularly, to fluid flow sensing devices and methods utilizing sensor shielding.

#### BACKGROUND

15           An oil and gas well is shown in Figure 1 generally at 60. Well construction involves drilling a hole or borehole 62 in the surface 64 of land or ocean floor. The borehole 62 may be several thousand feet deep, and drilling is continued until the desired depth is reached. Fluids such as oil, gas and water reside in porous rock formations 68. A casing 72 is normally lowered into the borehole 62. The region between the casing 72 and rock formation 68 is filled with cement 70 to provide a hydraulic seal. Usually, tubing 74 is inserted into the hole 62, the  
20 tubing 74 including a packer 76 which comprises a seal. A packer fluid 78 is disposed between the casing 72 and tubing 74 annular region. Perforations 80 may be located in the casing 72 and cement 70, into the rock 68, as shown.

          Production logging involves obtaining logging information about an active oil, gas or water-injection well while the well is flowing. A logging tool instrument package comprising sensors is lowered into a well, the well is  
25 flowed and measurements are taken. Production logging is generally considered the best method of determining actual downhole flow. A well log, a collection of data from measurements made in a well, is generated and is usually presented in a long strip chart paper format that may be in a format specified by the American Petroleum Institute (API), for example.

The general objective of production logging is to provide information for the diagnosis of a well. A wide variety of information is obtainable by production logging, including determining water entry location, flow profile, off depth perforations, gas influx locations, oil influx locations, non-performing perforations, thief zone stealing production, casing leaks, crossflow, flow behind casing, verification of new well flow integrity, and floodwater breakthrough, as examples. The benefits of production logging include increased hydrocarbon production, decreased water production, detection of mechanical problems and well damage, identification of unproductive intervals for remedial action, testing reservoir models, evaluation of drilling or completion effectiveness, monitoring Enhanced Oil Recovery (EOR) process, and increased profits, for example. An expert generally performs interpretation of the logging results.

In current practice, measurements are typically made in the central portion of the wellbore cross-section, such as of spinner rotation rate, fluid density and dielectric constant of the fluid mixture. These data may be interpreted in an attempt to determine the flow rate at any point along the borehole. Influx or exit rate over any interval is then determined by subtracting the flow rates at the two ends of the interval.

In most producing oil and gas wells, the wellbore itself generally contains a large volume percentage or fraction of water, but often little of this water flows to the surface. The water that does flow to the surface enters the wellbore, which usually already contains a large amount of water. The presence of water already in the wellbore, however, makes detection of the additional water entering the wellbore difficult and often beyond the ability of conventional production logging tools.

Furthermore, in deviated and horizontal wells with multiphase flow, and also in some vertical wells, conventional production logging methods are frequently misleading due to complex and varying flow regimes or patterns that cause misleading and non-representative readings. Generally, prior art production logging is performed in these complex flow regimes in the central area of the borehole and yields frequently misleading results, or may possess other severe limitations. Often the location of an influx of water, which is usually the information desired from production logging, is not discernable due to the small change in current measurement responses superimposed upon large variations caused by the multiphase flow conditions.

U.S. Patent Application Serial No. 09/880,402, filed June 13, 2001, entitled "Conductive Fluid Logging Sensor and Method," now issued as U.S. Patent No. 6,711,947 B2, Serial No. 10/600,053, filed June 20, 2003, entitled "Conductive Fluid Logging Sensor and Method," now issued as U.S. Patent No. 6,799,407 B2, and Serial No. 10/924,320, filed August 23, 2004, entitled "Fluid Flow Measuring Device and Method of Manufacturing Thereof," disclose apparatuses and methods for measuring the flow of fluid as it enters or exits an interior wall of a fluid conduit before the fluid becomes substantially intermixed with the fluids and the often complex flow pattern already in the fluid conduit. In particular, the apparatuses and methods may be used to measure the radial flow of conductive fluid through the wall of a fluid conduit, generally without being sensitive to non-conductive fluid flow or to non-radial conductive fluid flow. As an application example, embodiments may be used to detect and measure the radial flow of water through the conduit or borehole wall of an oil or gas well.

As described in the above-referenced patent applications, an electric field is induced when water or generally any material moves through a magnetic field. When the material has at least a small amount of conductivity, the voltage difference generated by the induced electric field between two points may be measured.

Generally, the voltage from the induced electric field is proportional to the velocity of the fluid medium. If this voltage is measured, the velocity of the medium may be determined.

In some cases, however, another effect may also contribute to the measured voltage. In particular, a voltage drop due to the circulation of electrical currents in the fluid may introduce an extra voltage component into the measured voltage. These circulating electrical currents generally may be caused by the ubiquitous induced electric fields in the vicinity of the two electrodes, and may depend upon the velocity distribution of the fluid, as well as the values and locations of all the induced electric fields in the proximity of the measure electrodes.

Generally, the voltage difference in a localized area (such as between two closely spaced electrodes) contributed by these circulating currents is dependent upon the conductivity of the medium and the localized current density. In addition, the value of the circulating current may change from point to point. Thus, under some circumstances or in some applications, the measured voltage difference between two electrodes may introduce an error component and interfere with a reasonably accurate fluid velocity measurement.

## SUMMARY OF THE INVENTION

These and other problems are generally solved or circumvented, and technical advantages are generally achieved, by preferred embodiments of the present invention that utilize shields between electrode pairs. Generally, shields substantially reduce or prevent circulating currents from contributing an undesired component to the measured voltage, thus helping to ensure that the voltage measurement provides a voltage value that is proportional to the velocity of the fluid flow.

In a preferred embodiment of the present invention, using shields between groups of electrodes generally inhibits or prevents circulating electrical currents from causing a voltage difference that would adversely affect the measured voltage difference between two adjacent electrodes. Generally, once the circulating electrical current flow between the electrode pairs is substantially reduced or eliminated, only the voltage difference from the localized induced electric field remains. This way, a true induced voltage may be measured, and thus an accurate value for the fluid velocity may be determined.

The foregoing has outlined rather broadly the features and technical advantages of the present invention in order that the detailed description of the invention that follows may be better understood. Additional features and advantages of the invention will be described hereinafter which form the subject of the claims of the invention. It should be appreciated by those skilled in the art that the conception and specific embodiment disclosed may be readily utilized as a basis for modifying or designing other structures or processes for carrying out the same purposes of the present invention. It should also be realized by those skilled in the art that such equivalent constructions do not depart from the spirit and scope of the invention as set forth in the appended claims.

20

## BRIEF DESCRIPTION OF THE DRAWINGS

For a more complete understanding of the present invention, and the advantages thereof, reference is now made to the following descriptions taken in conjunction with the accompanying drawings, in which:

Figure 1 is a cross-section view of an oil or gas well;

5 Figure 2A shows a perspective view of the sensor loop moving towards a water inflow;

Figure 2B shows a perspective view of the sensor loop positioned over a water inflow, and thus sensing the water inflow;

Figure 3A is a perspective view of a rectangular shield;

Figure 3B is a perspective view of a circular shield;

10 Figure 4 is a perspective view of a rectangular shield having a mid-section narrower than the ends;

Figure 5 is a perspective view of a rectangular shield having a mid-section wider than the ends;

Figure 6 is a perspective view of a circular shield having a mid-section narrower than the ends;

Figure 7 is a perspective view of a circular shield having a mid-section wider than the ends;

Figure 8 is a perspective view of a rectangular shield having a tapered perimeter;

15 Figure 9 is a perspective view of a circular shield having a tapered circumference;

Figure 10 is a perspective view of a rectangular shield having point electrodes;

Figure 11 is a perspective view of a rectangular shield having medium-sized electrodes;

Figure 12 is a perspective view of a rectangular shield having large-sized electrodes;

20 Figure 13 is a perspective view of a rectangular shield wherein electrodes are mounted on opposing sides of the rectangular shield;

Figure 14 is a perspective view of multiple rectangular shields;

Figure 15 is a perspective view of multiple circular shields; and

Figure 16 is a perspective view of multiple circular shields wherein the space between the circular shields is filled.

25

## DETAILED DESCRIPTION OF ILLUSTRATIVE EMBODIMENTS

The making and using of the presently preferred embodiments are discussed in detail below. It should be appreciated, however, that the present invention provides many applicable inventive concepts that can be embodied in a wide variety of specific contexts. The specific embodiments discussed herein are merely illustrative of specific  
5 ways to make and use the invention, and do not limit the scope of the invention.

The present invention will be described with respect to preferred embodiments in a specific context, namely an apparatus and method for detecting radial water flow through the borehole wall of an oil or gas well. The invention may also be applied, however, to other apparatuses and methods that generally would benefit from the detection of conductive fluid flow in one direction while being insensitive to nonconductive fluid flow in the same  
10 direction or to either type of fluid flow in orthogonal directions. For example, the invention may be used to detect conductive fluid flow leaks in some other type of fluid conduit, such as a water pipeline, a chemical line or a sewer line.

As will be described in detail below, a wide variety of shield designs and electrode designs may be used in accordance with preferred embodiments of the present invention. All of these designs, as well as many other  
15 variations that one of ordinary skill in the art would understand to be within the scope of the present invention, may be used with the apparatuses and methods disclosed in U.S. Patent Application Serial No. 09/880,402, filed June 13, 2001, entitled "Conductive Fluid Logging Sensor and Method," now issued as U.S. Patent No. 6,711,947 B2, Serial No. 10/600,053, filed June 20, 2003, entitled "Conductive Fluid Logging Sensor and Method," now issued as U.S. Patent No. 6,799,407 B2, and Serial No. 10/924,320, filed August 23, 2004, entitled "Fluid Flow Measuring Device  
20 and Method of Manufacturing Thereof". For example, the shield and electrode designs disclosed herein may be used with the devices disclosed in Figures 2-10 of the above-mentioned patent applications.

Figure 2A schematically illustrates a perspective view of a sensor loop 108 positioned against the inside of the casing 111b wall as described in U.S. Patent Application Serial No. 09/880,402, filed June 13, 2001, entitled "Conductive Fluid Logging Sensor and Method," now issued as U.S. Patent No. 6,711,947 B2, Serial No.  
25 10/600,053, filed June 20, 2003, entitled "Conductive Fluid Logging Sensor and Method," now issued as U.S. Patent No. 6,799,407 B2, and Serial No. 10/924,320, filed August 23, 2004, entitled "Fluid Flow Measuring Device and Method of Manufacturing Thereof," which are incorporated herein by reference, having shields 120 interposed between adjacent pairs of sensors. Generally, the sensor loop 108 is adapted to move upward and downward over perforation holes 112 through the casing 111b towards an inflow of water 113 through perforation holes 112.

In an oil or gas well, water inflow is undesirable, therefore the location of the water inflow is important information to obtain so that the casing 111b can be repaired, for example. No inflow of water is measured in the sensor loop 108 position shown in Figure 2A, because there is no inflow of water 113 anywhere over the sensor loop 108. Preferably, the sensor loop 108 remains flush with the casing 111b to maintain close proximity to regions of inflow of water 113, in order to directly sense the inflow of water 113. Figure 2B shows the sensor loop 108 against  
30 the inside of the casing wall 111b moving downward and actually at the location of the inflow of water 113 through a perforation hole 112. In this position the sensor loop 108 detects the inflow of water 113.  
35

In accordance with an embodiment of the present invention, one or more shields 120 are positioned between groups of electrodes in a sensor loop, wherein each group of electrodes may have two or more electrodes. (Pairs of electrodes are illustrated herein for illustrative purposes only.) While the shape and size of the shields 120 may vary, it should be noted that at least a portion of each electrode should be exposed to the fluid to allow  
5 detection of conductive fluid flow. The position of the electrode with respect to the shield may be adjusted to maximize the detection of conductive fluid flow.

The shields 120 may be formed of a conducting material (*e.g.*, a metal) or an insulating material (*e.g.*, a dielectric). Use of an insulating material, such as a plastic, however, is generally preferable.

The shields 120 may be of any design that adequately prevents or reduces the circulating electrical currents  
10 from interfering with measurement of the voltage difference caused by a conductive fluid flow induced electric field. It should be noted, however, that the shields 120 are illustrated in Figures 2a and 2b as single planar dividers interposed between pairs of electrodes for illustrative purposes only to illustrate the desired isolation effect between groups of electrodes. Preferably, the shields 120 form a conduit through which the conductive fluid flow passes. The shields 120 may, for example, be tubes having circular, square, rectangular, triangular, elliptical, hexagonal,  
15 octagonal, irregular-shaped, a combination of any of the above, or the like cross-section. Generally, any shape shield may be used that allows fluid flow in the desired direction while substantially inhibiting circulating electrical currents from interfering with the electrodes.

Figures 3a and 3b are perspective views of shields having a square cross-section and a circular cross-section, respectively, in accordance with an embodiment of the present invention. Referring first to Figure 3a, a  
20 square shield 310 is illustrated. The square shield 310 preferably has solid surfaces 312 and open ends 314, thereby allowing fluids to flow through the square shield 310 as indicated by directional arrows 316. Similarly, Figure 3b illustrates a cylindrical shield 320 having a solid side surface 322 and open ends 324. Other shapes may be used.

The shields, such as those illustrated in Figures 3a and 3b, are preferably positioned such that the flow of fluid flowing through the shields is substantially parallel to the flow of conductive fluid that is to be detected. In the  
25 embodiment of the borehole discussed above, the shields are preferably positioned such that the flow of fluid through the shields is substantially orthogonal to the longitudinal axis of the borehole or conduit in order to detect the radial flow of conductive fluid through the wall of the borehole or conduit. In this manner, the interference from the induced electric field due to the flow of conductive fluid is limited and limits the interference to adjacent sensors.

Additional variations in the shield design are possible, with the primary object being to block the  
30 circulating electrical currents from the electrodes. Some of these designs may help increase the mechanical strength of the measurement sensor loop or improve the manufacturability or other aspects of preferred embodiments of the invention. For example, one variation is a conduit having varying inner dimensions along the direction of fluid flow through the shield. The shields may have a rectangular cross-section such that the perimeter is reduced in a mid-  
35 region along the direction of the fluid flow as illustrated in Figure 4, a rectangular cross-section such that the perimeter is enlarged in a mid-region along the direction of the fluid flow as illustrated in Figure 5, a circular cross-section such that the circumference is reduced in a mid-region along the direction of fluid flow as illustrated in Figure 6, or a circular cross-section such that the circumference is enlarged in a mid-region along the direction of

fluid flow as illustrated in Figure 7. Similar shields may be used having different cross-section shapes, such as circular, square, triangular, elliptical, hexagonal, octagonal, irregular in shape, a combination of any of the above, or the like cross-section.

It should be noted that Figures 4-7 illustrate embodiments in which the cross-section of the ends (the entry and exit points of the fluid) are congruent for illustrative purposes only, and that the cross-section of the ends of a shield may be of different sizes. For example, shields may be used that have a tapered, increasing or decreasing, shape along the fluid flow. For example, Figure 8 illustrates a rectangular-tapered shield 800 having a rectangular cross-section such that the perimeter of a receiving end 810 is greater than the perimeter of an exiting end 812, and Figure 9 illustrates a circular-tapered shield 900 having a circular cross-section such that the circumference of a receiving end 910 is greater than the perimeter of an exiting end 912. It should be noted that the receiving ends 810 and 910 are illustrated as being larger than the exiting ends 812 and 912, respectively, for illustrative purposes only. Other embodiments of the present invention may orient the shields such that the expected fluid flow enters the narrower end (*e.g.*, ends 812 and 912) and exits the larger end (*e.g.*, ends 810 and 910). Furthermore, the thickness of the floor, sides and roof of each shield may be different from each other.

Figure 10 illustrates a rectangular shield 1000 having point electrodes 1008 in accordance with an embodiment of the present invention. It should be noted that the rectangular shield 1000 is illustrated as having transparent sides for illustrative purposes to better illustrate the placement of the point electrodes 1008. As illustrated in Figure 10, the point electrodes are located along the inner side of opposing sidewalls 1010 and 1012. The point electrodes may be placed along the sidewalls 1010 and 1012, as illustrated in Figure 10, or along the top wall 1014 and the bottom wall 1016. Additionally, the point electrodes 1008 may be positioned in the middle of the shield, or closer to either end. However, it is preferred that the point electrodes be arranged such that a line drawn connecting the point electrodes 1008 is orthogonal to the conductive fluid flow. It should be noted that the sensors (not shown) are preferably mounted along opposing interior walls of the shields as described below.

As other examples, Figures 11 and 12 illustrate medium-sized electrodes 1108 and large-sized electrodes 1208, respectively, in accordance with an embodiment of the present invention. In these embodiments, the point electrodes 1008 of Figure 10 are replaced with longitudinal electrodes, such as the medium-sized electrodes 1108 of Figure 11 and the large-sized electrodes 1208 of Figure 12. The position of the medium-sized electrodes 1108 and the large-sized electrodes 1208 may be varied (*e.g.*, closer to either end of the conduit), but it is preferred that the medium-sized electrodes 1108 and the large-sized electrodes 1208 be arranged such that a line drawn connecting the electrodes is orthogonal to the conductive fluid flow.

Figure 13 illustrates an example of large area electrodes that may be used in accordance with the present invention. In particular, Figure 13 illustrates an example in which the electrodes cover a larger area, such as the sides of shield 1300. In the embodiment illustrated in Figure 13, electrodes 1308 substantially cover opposing sides 1310 and 1312 of the shield 1300. In this embodiment, it is preferred that the top 1314 and the bottom 1316 be formed of a dielectric or insulating material. This type of electrode may have the advantage of the measured voltage difference being independent of the fluid velocity distribution within the given shield, although this may not be a problem with a smaller shield. A circular shield with point electrodes at the ends of the appropriate diameter provides a measured voltage that should indicate an accurate fluid velocity regardless of whether any currents are

circulating within the shield, as long as the fluid flow is axially symmetric within the circular tube or column (again, currents circulating within a small shield generally should not be a problem in practice).

Alternatively, the electrodes may take on other shapes (*e.g.*, curved, spiral, etc.) and other orientations (*e.g.*, horizontal, diagonal, etc.), or combinations of the above. Preferably, each electrode is exposed to fluid flow on each side of the sidewall to which it is mounted. Alternatively, separate electrodes may be mounted on each side of a given sidewall.

For various reasons, empirical calibration of the fluid flow velocity preferably may be used, and may even be necessary.

It should be noted that some variation in the nominally regular spacing of the electrodes could be used to give greater mechanical strength to the sensor loop. Also, some occasional variations in the overall thickness of the sensor loop shields may be used to enhance mechanical strength while maintaining a small overall size for running into and out of a well. Other means may be used for strengthening the sensor loop, such as a strong flexible insert above or below the shields, or a strong top layer on top of the shields. Other possible ways to mechanically strengthen the sensor loop are possible and are considered to be within the spirit and scope of the present invention.

Figures 14-16 illustrate embodiments of the present invention in which multiple shields are used with multiple electrodes. In particular, Figure 14 illustrates the use of multiple rectangular shields to isolate adjacent groups (two or more) electrodes (not shown), and Figure 15 illustrates the use of multiple circular shields to isolate adjacent groups of electrodes (not shown). Figure 16 is similar to Figure 15, except that the space between the circular shields is filled with a dielectric or insulating material. This embodiment may have the added advantage of providing additional shielding and providing additional mechanical support for the sensor ring.

These configurations may be used on a sensor loop as disclosed in the previously mentioned patent applications, such as patent application Serial No. 09/880,402, now U.S. Patent No. 6,711,947. In particular, the configuration of Figure 11 of the present disclosure may be used on radial sensing device 108 in Figures 2-4, 5D and 6 of patent application Serial No. 09/880,402, now U.S. Patent No. 6,711,947. Furthermore, the configuration of Figure 11 of the present disclosure may be used for electrodes 129 in Figures 8-9 and 10A-10B of patent application Serial No. 09/880,402, now U.S. Patent No. 6,711,947. Again, both the shields and the electrodes may be any of a wide variety of designs, some of which have been discussed above.

Although the present invention and its advantages have been described in detail, it should be understood that various changes, substitutions and alterations can be made herein without departing from the spirit and scope of the invention as defined by the appended claims. For example, different shield designs may be used within a single sensor loop, or different electrode designs may be used within a single sensor loop.

Moreover, the scope of the present application is not intended to be limited to the particular embodiments of the process, machine, manufacture, composition of matter, means, methods and steps described in the specification. As one of ordinary skill in the art will readily appreciate from the disclosure of the present invention, processes, machines, manufacture, compositions of matter, means, methods, or steps, presently existing or later to be developed, that perform substantially the same function or achieve substantially the same result as the corresponding

embodiments described herein may be utilized according to the present invention. Accordingly, the appended claims are intended to include within their scope such processes, machines, manufacture, compositions of matter, means, methods, or steps.

## WHAT IS CLAIMED IS:

1. A logging tool for a borehole, the borehole having an interior wall, the logging tool comprising:
  - a tool body adapted to be inserted into the borehole;
  - a sensing device coupled to the tool body, the sensing device adapted to detect radial flow of conductive
- 5 fluid entering or leaving the borehole interior wall, the sensing device being adapted to detect the conductive fluid flow adjacent the borehole interior wall;
  - shields disposed along the sensing device; and
  - voltage sensing electrodes disposed on the interior surfaces of the shields.
2. The logging tool of claim 1, wherein the shields are interconnected.
- 10 3. The logging tool of claim 1, wherein the shields comprise a conduit through which fluid may flow.
4. The logging tool of claim 1, wherein the voltage sensing electrodes comprise a point electrode.
5. The logging tool of claim 1, wherein the voltage sensing electrodes comprise a longitudinal electrode.
6. The logging tool of claim 1, wherein the voltage sensing electrodes substantially cover opposing sides of
- 15 7. A fluid flow measuring device, comprising:
  - a plurality of resistors disposed in a circular pattern;
  - a plurality of shields disposed along the fluid flow measuring device in a circular pattern;
  - a plurality of electrodes, each electrode coupled between two adjacent resistors and disposed on an interior
- 20 surface wall of one of the shields;
  - a first coil of wire adapted to generate a magnetic field wound proximate the resistors and electrodes;
  - a second coil of wire adapted to generate a magnetic field wound proximate the resistors and electrodes;
  - and
  - a voltage measuring mechanism electrically coupled between two of the resistors, wherein a flow of
- 25 8. The fluid flow measuring device of claim 7, wherein the shields are interconnected.

9. The fluid flow measuring device of claim 7, wherein the shields comprise a conduit through which fluid may flow.
10. The fluid flow measuring device of claim 7, wherein the electrodes comprise a point electrode.
11. The fluid flow measuring device of claim 7, wherein the electrodes comprise a longitudinal electrode.
- 5 12. The fluid flow measuring device of claim 7, wherein the electrodes substantially cover opposing sides of the shields.
13. A method of measuring radial fluid flow in a borehole having an interior wall, the method comprising:  
traversing the borehole with a tool body having a sensor loop attached thereto, wherein shields are disposed along the sensor loop, and wherein voltage sensing electrodes are disposed on the interior surfaces of the shields;  
10 and  
detecting a radial flow of conductive fluid entering or leaving the borehole interior wall.
14. The method of claim 13, wherein the shields are interconnected.
15. The method of claim 13, wherein the shields comprise a conduit through which fluid may flow.
16. The method of claim 13, wherein the voltage sensing electrodes comprise a point electrode.
- 15 17. The method of claim 13, wherein the voltage sensing electrodes comprise a longitudinal electrode.
18. The method of claim 13, wherein the voltage sensing electrodes substantially cover opposing sides of the shields.
19. A fluid flow measuring device, comprising:  
a plurality of shields disposed along a curved loop;  
20 a series-coupled plurality of alternating electrodes and resistors, wherein each of the electrodes is disposed on an interior surface wall of one of the shields;  
a magnetic field source, the magnetic field source oriented to generate a magnetic field between adjacent electrodes, the magnetic field substantially orthogonal to an imaginary line intersecting the adjacent electrodes; and

a voltage measuring circuit electrically coupled to the plurality of alternating electrodes and resistors, the voltage measuring circuit coupled to measure a voltage difference between the adjacent electrodes, the voltage difference representative of a radial flow of conductive fluid substantially orthogonal to both the imaginary line and the magnetic field.

- 5 20. The fluid flow measuring device of claim 19, wherein the shields are interconnected.
21. The fluid flow measuring device of claim 19, wherein the shields comprise a conduit through which fluid may flow.
22. The fluid flow measuring device of claim 19, wherein the electrodes comprise a point electrode.
23. The fluid flow measuring device of claim 19, wherein the electrodes comprise a longitudinal electrode.
- 10 24. The fluid flow measuring device of claim 19, wherein the electrodes substantially cover opposing sides of the shields.

25. A method of manufacturing a fluid flow measuring device, the method comprising:  
disposing a plurality of shields on a sensor loop;  
disposing a plurality of electrodes on interior surface walls of the shields;  
disposing a plurality of resistors on the sensor loop;  
5 electrically coupling the electrodes and resistors in an alternating series;  
disposing a magnetic field source on the sensor loop proximate the electrodes, wherein the magnetic field source is oriented to generate a magnetic field substantially orthogonal to an imaginary line intersecting adjacent electrodes; and  
electrically coupling a voltage measuring circuit to the plurality of alternating electrodes and resistors, the  
10 circuit coupled to measure a voltage difference between adjacent electrodes, the voltage difference representative of a radial flow of conductive fluid substantially orthogonal to both the imaginary line and the magnetic field.
26. The method of claim 25, wherein the shields are interconnected.
27. The method of claim 25, wherein the shields comprise a conduit through which fluid may flow.
28. The method of claim 25, wherein the electrodes comprise a point electrode.
- 15 29. The method of claim 25, wherein the electrodes comprise a longitudinal electrode.
30. The method of claim 25, wherein the electrodes substantially cover opposing sides of the shields.
31. An inspection tool for a casing, the casing having an interior wall, the inspection tool comprising:  
a tool body adapted to be inserted into the casing;  
an electromagnetic sensing device coupled to the tool body, the electromagnetic sensing device having a  
20 plurality of electrodes positioned substantially equidistance from the interior wall and having a plurality of shields, each shield comprising a conduit through which fluid may flow and having a plurality of the electrodes therein; and  
a magnetic field generator coupled to the tool body, the magnetic field generator adapted to generate a magnetic field substantially perpendicular to an imaginary line between two adjacent electrodes;  
wherein the electromagnetic sensing device is adapted to measure an induced voltage caused by an inflow  
25 or outflow of conductive fluid through the interior wall of the casing.

32. The inspection tool according to claim 31, wherein the magnetic field is an alternating magnetic field.
33. The inspection tool according to claim 31, wherein the electromagnetic sensing device comprises a sensor loop, the sensor loop being adapted to exert outward pressure to maintain the sensor near the interior wall of the casing while the tool traverses the casing.
- 5 34. The inspection tool according to claim 33, wherein the sensor loop includes a spring disposed within the sensor loop to exert outward pressure.
35. The inspection tool according to claim 33, wherein the sensor loop is a continuous ring, wherein an inflow or outflow of conductive fluid is detectable along the circumference of the sensor loop.
- 10 36. The inspection tool according to claim 33, wherein the magnetic field generator comprises:  
a first coil of wire adapted to generate a magnetic field proximate the sensor loop;  
a second coil of wire adapted to generate a magnetic field proximate the sensor loop;  
a ferromagnetic material disposed between the two coils; and  
an alternating current generator coupled to the first coil and the second coil.
- 15 37. The inspection tool according to claim 31, wherein the electromagnetic sensing device further comprises:  
a plurality of resistors, at least one resistor being coupled between two adjacent electrodes; and  
a voltage measuring mechanism electrically coupled between two of the resistors.
38. The inspection tool according to claim 31, wherein the magnetic field generator comprises a first coil and a second coil.
- 20 39. The inspection tool according to claim 31, wherein the electromagnetic sensing device is coupled to the tool body at a loop high point and a loop low point, the loop high point and loop low point being about 180 degrees apart along the electromagnetic sensing device.
40. The inspection tool according to claim 31, wherein the electromagnetic sensing device is relatively insensitive to a flow of conductive fluid along a longitudinal axis of the casing.

41. An inspection tool for detecting a radial flow of conductive fluid through a casing, the inspection tool comprising:
- a tool body adapted to be inserted into the casing;
  - an electromagnetic sensing device coupled to the tool body, the electromagnetic sensing device having a plurality of electrodes and a plurality of shields, each shield having a plurality of electrodes therein; and
  - a magnetic field generator adapted to generate a magnetic field substantially perpendicular to the imaginary line between two adjacent electrodes;
- wherein the plurality of electrodes are oriented to detect the radial flow of conductive fluid through the casing.
42. The inspection tool according to claim 41, wherein the magnetic field generator generates an alternating magnetic field.
43. The inspection tool according to claim 41, wherein the electromagnetic sensing device comprises a sensor loop, the sensor loop being adapted to exert outward pressure to maintain the sensor near the casing interior wall while the tool traverses the casing.
44. The inspection tool according to claim 43, wherein the sensor loop includes a spring disposed within the sensor loop to exert outward pressure.
45. The inspection tool according to claim 43, wherein the sensor loop is a continuous ring, wherein an inflow or outflow of conductive fluid is detectable along the circumference of the sensor loop.
46. The inspection tool according to claim 43, wherein the magnetic field generator comprises:
- a first coil of wire adapted to generate a magnetic field proximate the sensor loop;
  - a second coil of wire adapted to generate a magnetic field proximate the sensor loop;
  - a ferromagnetic material disposed between the two coils; and
  - an alternating current generator coupled to the first coil and the second coil.
47. The inspection tool according to claim 41, wherein the electromagnetic sensing device further comprises:
- a plurality of resistors, at least one resistor being coupled between two adjacent electrodes; and
  - a voltage measuring mechanism electrically coupled between two of the resistors.

48. The inspection tool according to claim 41, wherein the alternating magnetic field generator comprises a first coil and a second coil.
49. The inspection tool according to claim 41, wherein the electromagnetic sensing device is coupled to the tool body at a loop high point and a loop low point, the loop high point and loop low point being about 180 degrees  
5 apart along the electromagnetic sensing device.
50. The inspection tool according to claim 41, wherein the electromagnetic sensing device is relatively insensitive to a flow of conductive fluid along a longitudinal axis of the casing.
51. A method of measuring radial fluid flow in a casing having an interior wall, the method comprising:  
traversing the casing with a tool body having a plurality of electrodes and a plurality of shields, each shield  
10 comprising a conduit through which fluid may flow and having two or more electrodes therein;  
generating a magnetic field substantially perpendicular to an imaginary line between adjacent electrodes;  
and  
measuring an induced voltage indicative of a substantially radial flow of conductive fluid entering or  
leaving the casing interior wall.
- 15 52. The method according to claim 51, wherein the magnetic field is an alternating magnetic field.
53. The method according to claim 51, further comprising maintaining the plurality of electrodes near the interior wall of the casing.
54. The method according to claim 51, wherein the plurality of electrodes are positioned on a sensor loop, and further comprising adjusting the sensor loop such that the sensor loop fits within the casing.
- 20 55. The method according to claim 54, wherein the adjusting includes changing the angle of the sensor loop with respect to a central axis of the casing.
56. A fluid flow measuring device, comprising:  
a plurality of resistors disposed in a circular pattern;  
a plurality of electrodes, at least one resistor being coupled between two adjacent electrodes;  
25 a plurality of shields having two or more of the electrodes therein;

a pair of coils adapted to generate a magnetic field proximate the resistors and electrodes, the pair of coils being substantially parallel to each other; and

a voltage measuring mechanism electrically coupled between two of the resistors, wherein the voltage measuring mechanism measures an induced voltage indicative of a flow of conductive fluid between two electrodes.

- 5 57. The fluid flow measuring device according to claim 56, wherein the magnetic field is an alternating magnetic field.
58. The fluid flow measuring device according to claim 56, wherein the pair of coils are electrically coupled to an alternating current source.
59. The fluid flow measuring device according to claim 56, further comprising a ferromagnetic material  
10 disposed between the two coils.
60. The fluid flow measuring device according to claim 59, wherein the ferromagnetic material comprises an iron alloy.
61. The fluid flow measuring device according to claim 56, wherein at least the resistors and electrodes are mounted on a sensor loop, the sensor loop being spring-loaded and being adapted to exert outward pressure to  
15 maintain the sensor loop near a casing interior wall.
62. The fluid flow measuring device according to claim 61, further comprising:  
means for maintaining the sensor loop near the casing interior wall over a range of casing diameters.
63. The fluid flow measuring device according to claim 61, wherein the sensor loop comprises a body comprising fluoropolymer resin.
- 20 64. The fluid flow measuring device according to claim 61, wherein the sensor loop is spring-loaded with a stainless steel spring wire.
65. The fluid flow measuring device according to claim 61, wherein the sensor loop has a substantially oval shape.

66. The fluid flow measuring device according to claim 56, wherein the coils comprise copper.
67. The fluid flow measuring device according to claim 56, wherein the plurality of resistors comprise values of between about 500,000 ohms and about 2,500,000 ohms.
68. The fluid flow measuring device according to claim 56, wherein at least the resistors and electrodes are  
5 mounted on a sensor loop, the sensor loop being spring-loaded to maintain the sensor loop near an interior wall of a fluid conduit.
69. A fluid flow measuring device, comprising:  
a series-coupled plurality of electrodes and resistors such that one or more resistors are coupled between adjacent electrodes;  
10 a plurality of shields having two or more of the electrodes therein;  
a magnetic field source, the magnetic field source oriented to generate a magnetic field between adjacent electrodes, the magnetic field substantially orthogonal to an imaginary line intersecting adjacent electrodes; and  
a voltage measuring circuit electrically coupled to the plurality of electrodes and resistors, the voltage measuring circuit coupled to measure a voltage difference between adjacent electrodes, the voltage difference  
15 representative of a flow of conductive fluid through the magnetic field.
70. The fluid flow measuring device according to claim 69, wherein the magnetic field is an alternating magnetic field.
71. The fluid flow measuring device according to claim 69, wherein the electrodes are disposed along a curved loop
- 20 72. The fluid flow measuring device according to claim 69, wherein the magnetic field source includes an alternating current source.
73. The fluid flow measuring device according to claim 69, wherein the voltage difference is proportional to a velocity of the radial flow of conductive fluid.
74. The fluid flow measuring device according to claim 69, wherein the magnetic field source comprises a first  
25 coil of wire proximate the electrodes.

75. The fluid flow measuring device according to claim 74, wherein the magnetic field source further comprises a second coil of wire proximate the electrodes and offset from the first coil of wire.
76. The fluid flow measuring device according to claim 75, wherein the magnetic field source further comprises a ferromagnetic material disposed between the first coil of wire and the second coil of wire.
- 5 77. The fluid flow measuring device according to claim 69, wherein the adjacent electrodes are spaced about 0.3 inches or less from each other.
78. The fluid flow measuring device according to claim 69, wherein the electrodes are mounted on a sensor loop, the sensor loop comprising a force loop exerting outwardly directed radial force.
79. The fluid flow measuring device according to claim 69, wherein the resistors comprise values of between  
10 about 500,000 ohms and about 2,500,000 ohms.
80. A method of manufacturing a fluid flow measuring device, the method comprising:  
disposing a plurality of electrodes spaced apart on a sensor loop;  
disposing a plurality of resistors on the sensor loop;  
disposing a plurality of shields having two or more electrodes therein;  
15 electrically coupling the electrodes and one or more resistors in an alternating series;  
disposing a magnetic field source on the sensor loop proximate the electrodes, wherein the magnetic field source is oriented to generate an magnetic field substantially orthogonal to an imaginary line intersecting adjacent electrodes; and  
electrically coupling a voltage measuring circuit to the plurality of alternating electrodes and resistors, the  
20 voltage measuring circuit coupled to measure a voltage difference between adjacent electrodes, the voltage difference representative of a radial flow of conductive fluid substantially orthogonal to both the imaginary line and the magnetic field.
81. The method of claim 80, wherein the magnetic field is an alternating magnetic field.
82. The method of claim 80, wherein the disposing the magnetic field source further comprises:  
25 disposing a first coil of wire on the sensor loop proximate the electrodes; and

disposing a second coil of wire on the sensor loop proximate the electrodes and offset from the first coil of wire.

83. The method of claim 82, wherein the disposing the magnetic field source further comprises disposing a ferromagnetic material between the first coil of wire and the second coil of wire.
- 5 84. The method of claim 80, wherein the electrodes are positioned along the exterior of the sensor loop.
85. The method of claim 80, wherein the electrodes are disposed on a surface of the sensor loop.
86. The method of claim 80, wherein the resistors and the magnetic field source are disposed under a surface of the sensor loop.
87. The method of claim 80, wherein the electrically coupling of the electrodes and resistors is performed  
10 before the disposing of the plurality of electrodes and the disposing of the plurality of resistors.
88. The method of claim 80, wherein the electrodes are regularly spaced on the sensor loop.
89. The method of claim 88, wherein adjacent electrodes are spaced about 0.3 inches or less from each other.
90. The method of claim 80, further comprising disposing a force loop on the sensor loop, wherein the force loop exerts outwardly directed radial force.
- 15 91. The method of claim 80, wherein the sensor loop has a substantially oval shape.

1/5

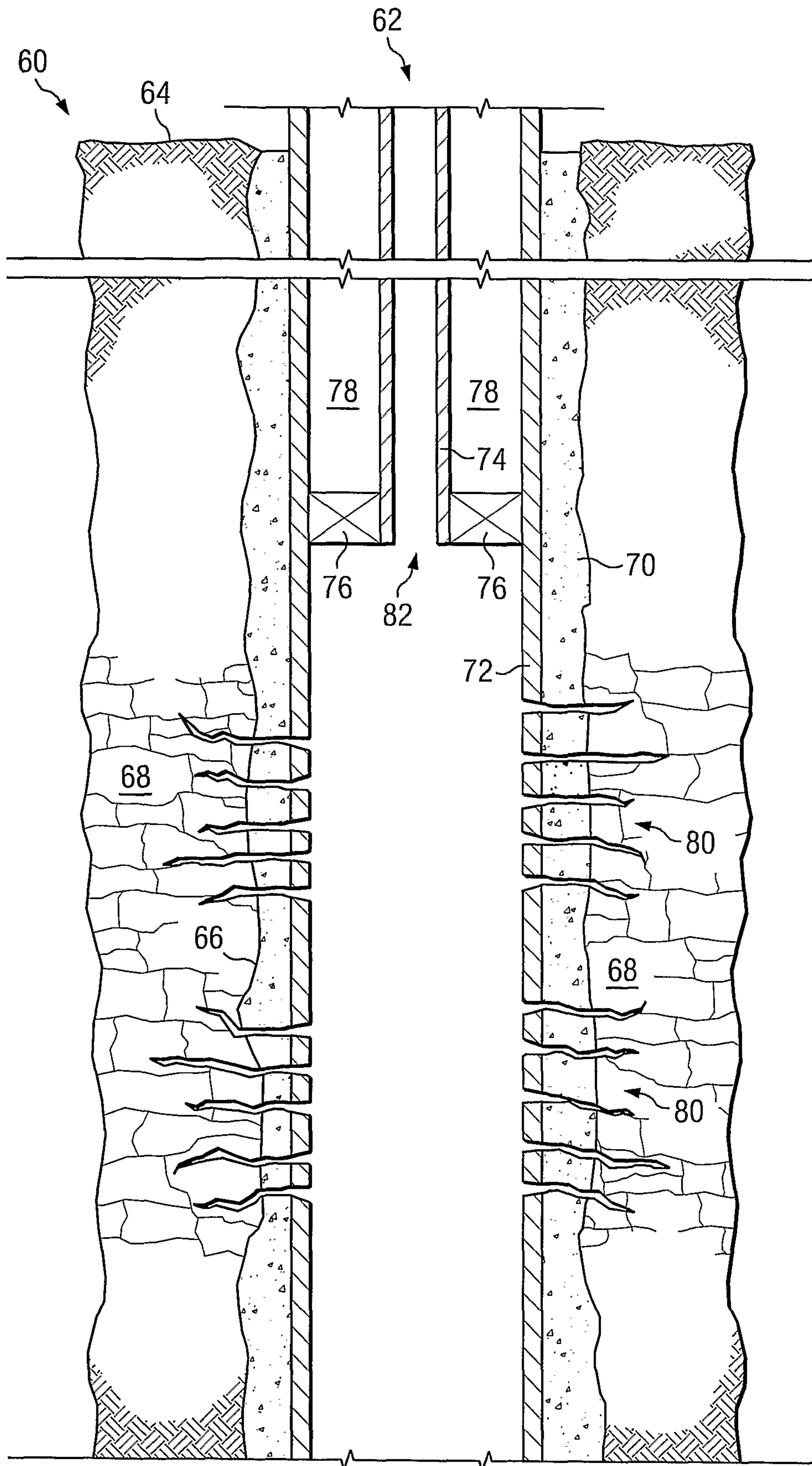

FIG. 1

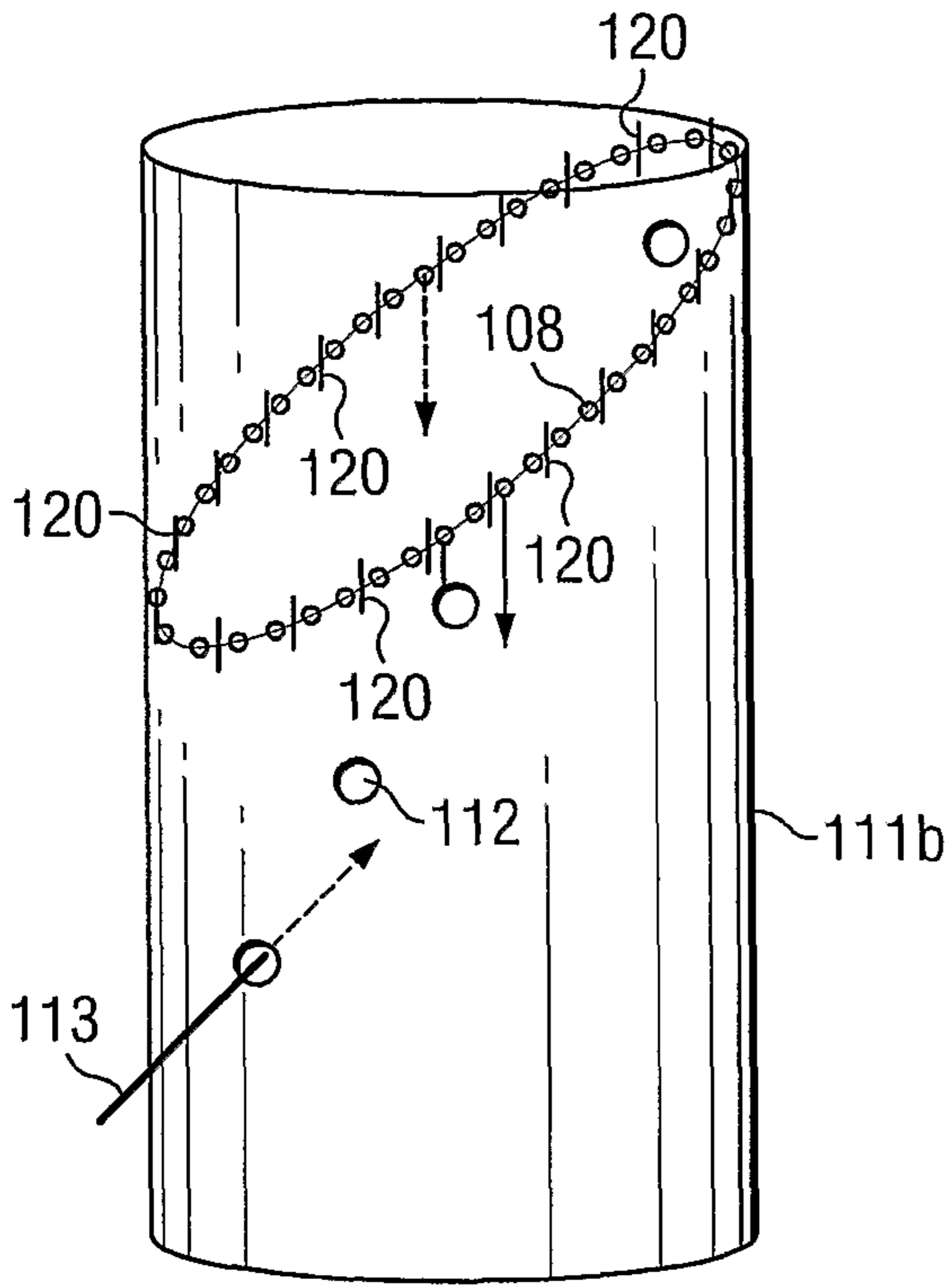

FIG. 2A

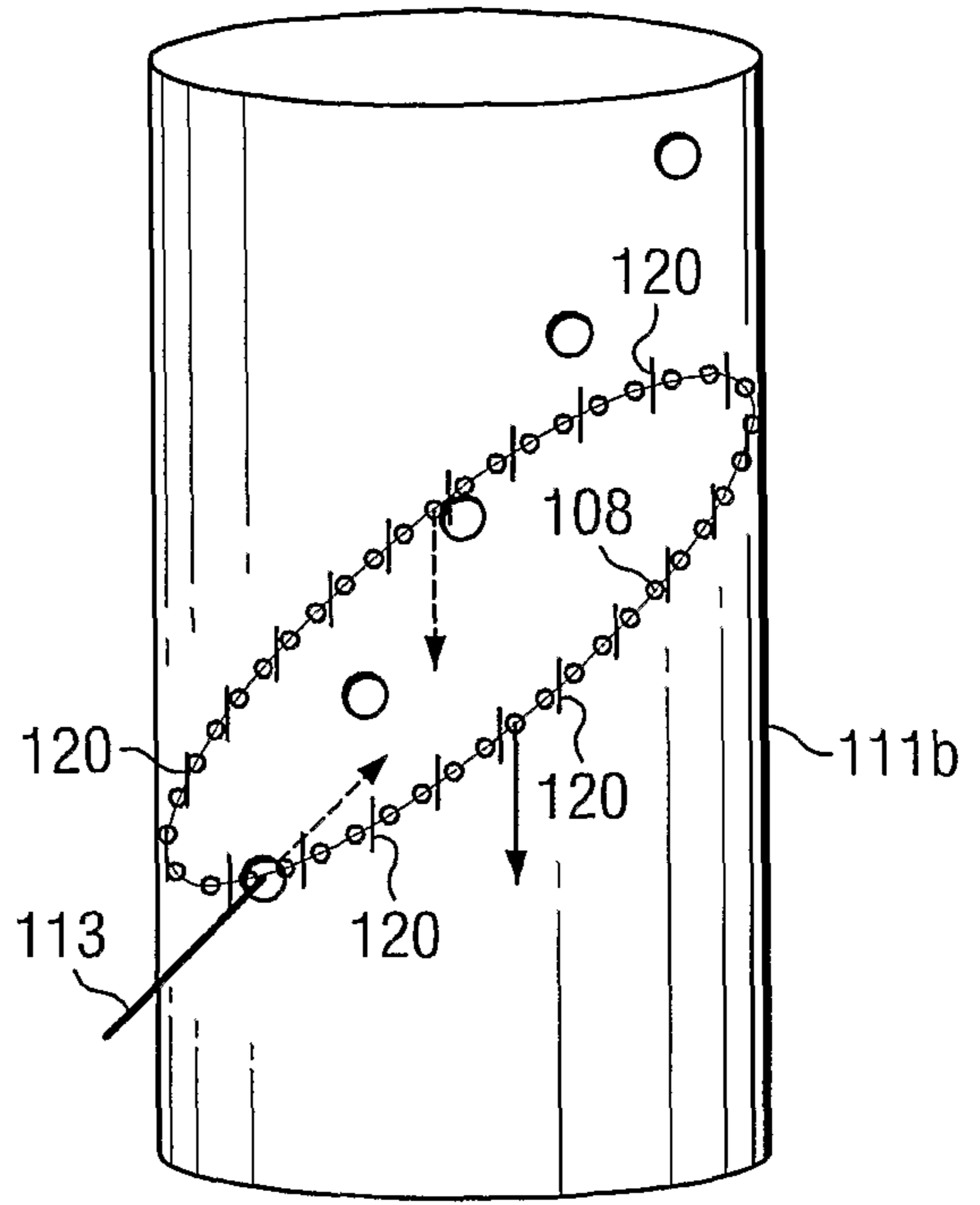

FIG. 2B

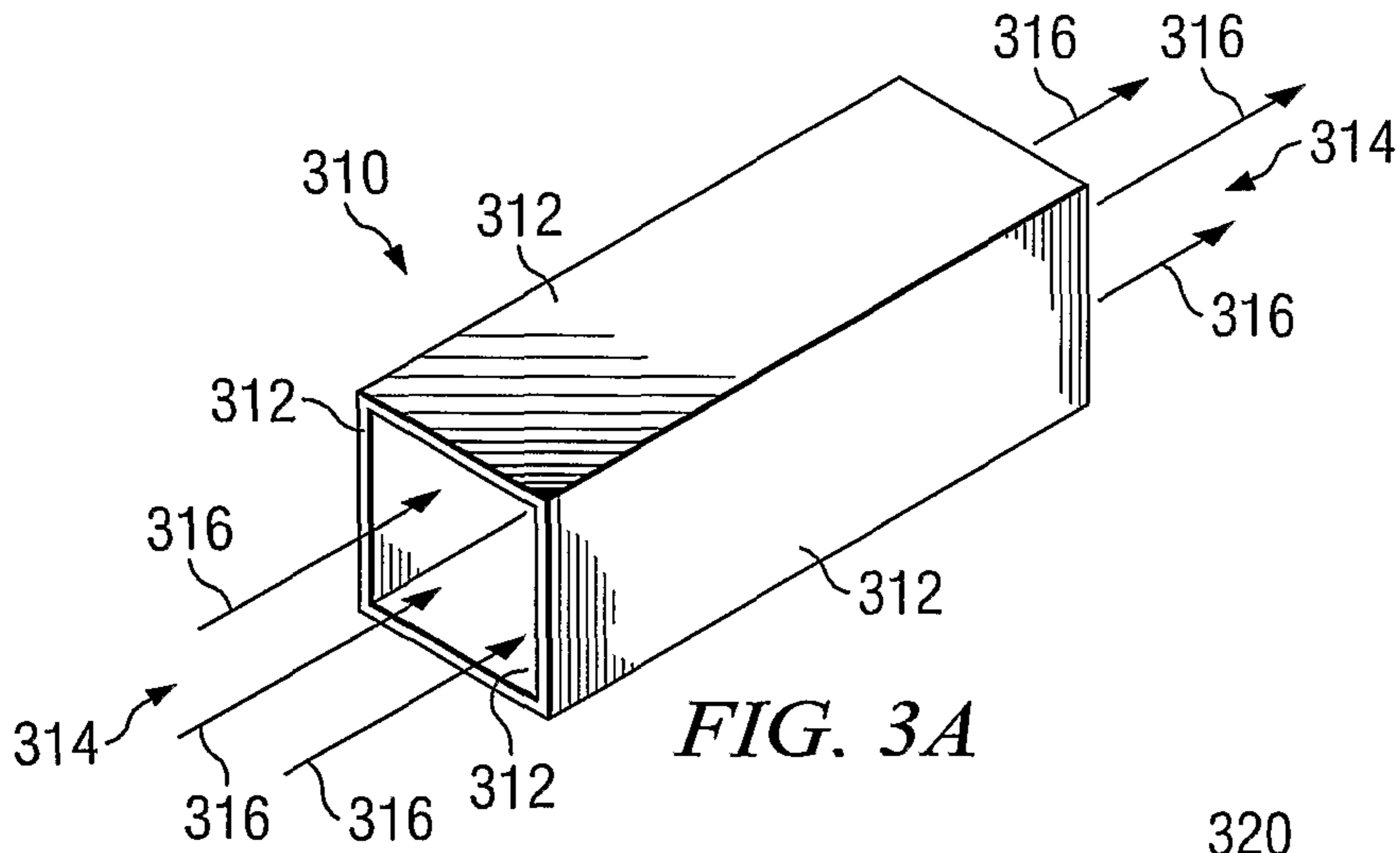

FIG. 3A

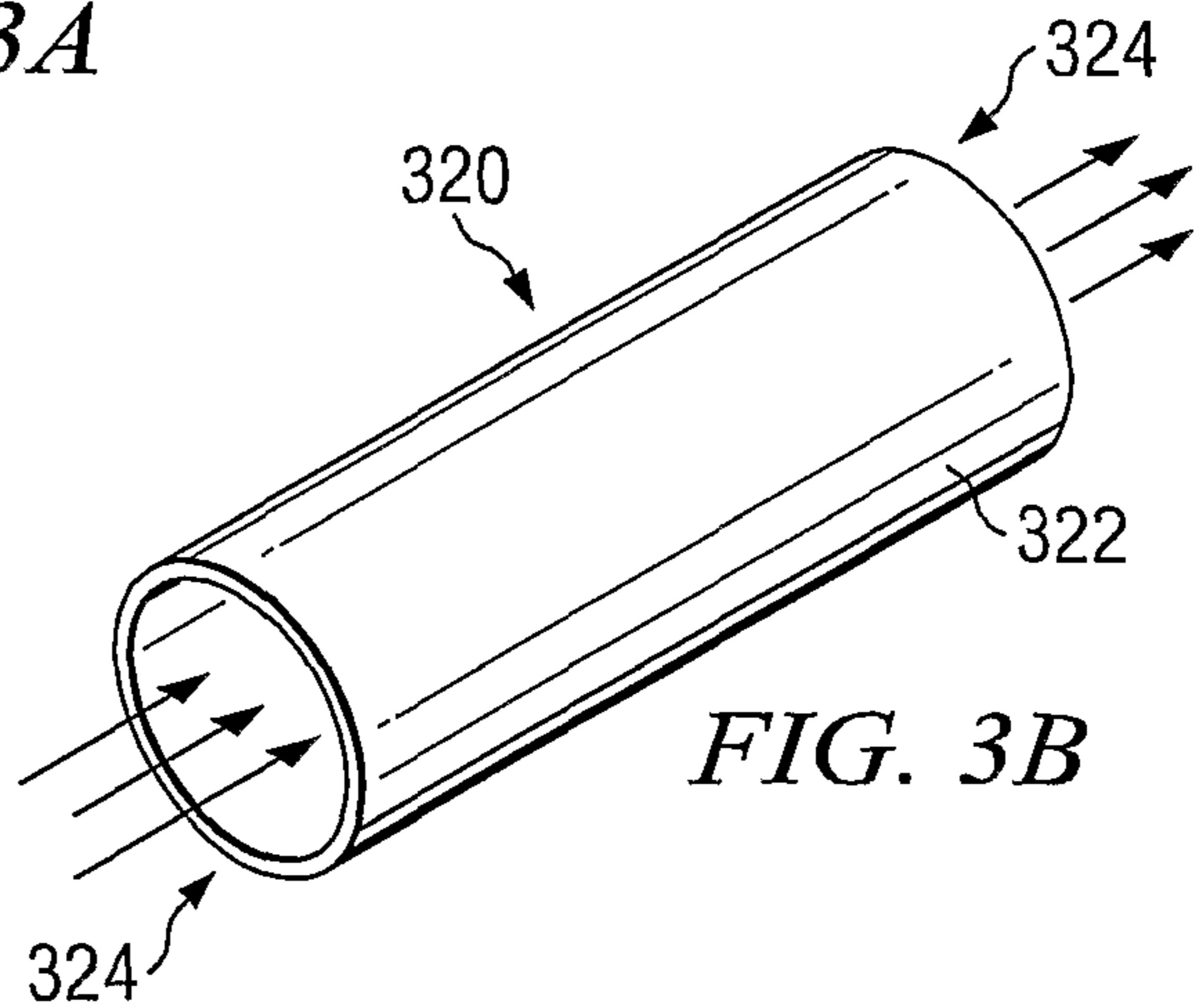

FIG. 3B

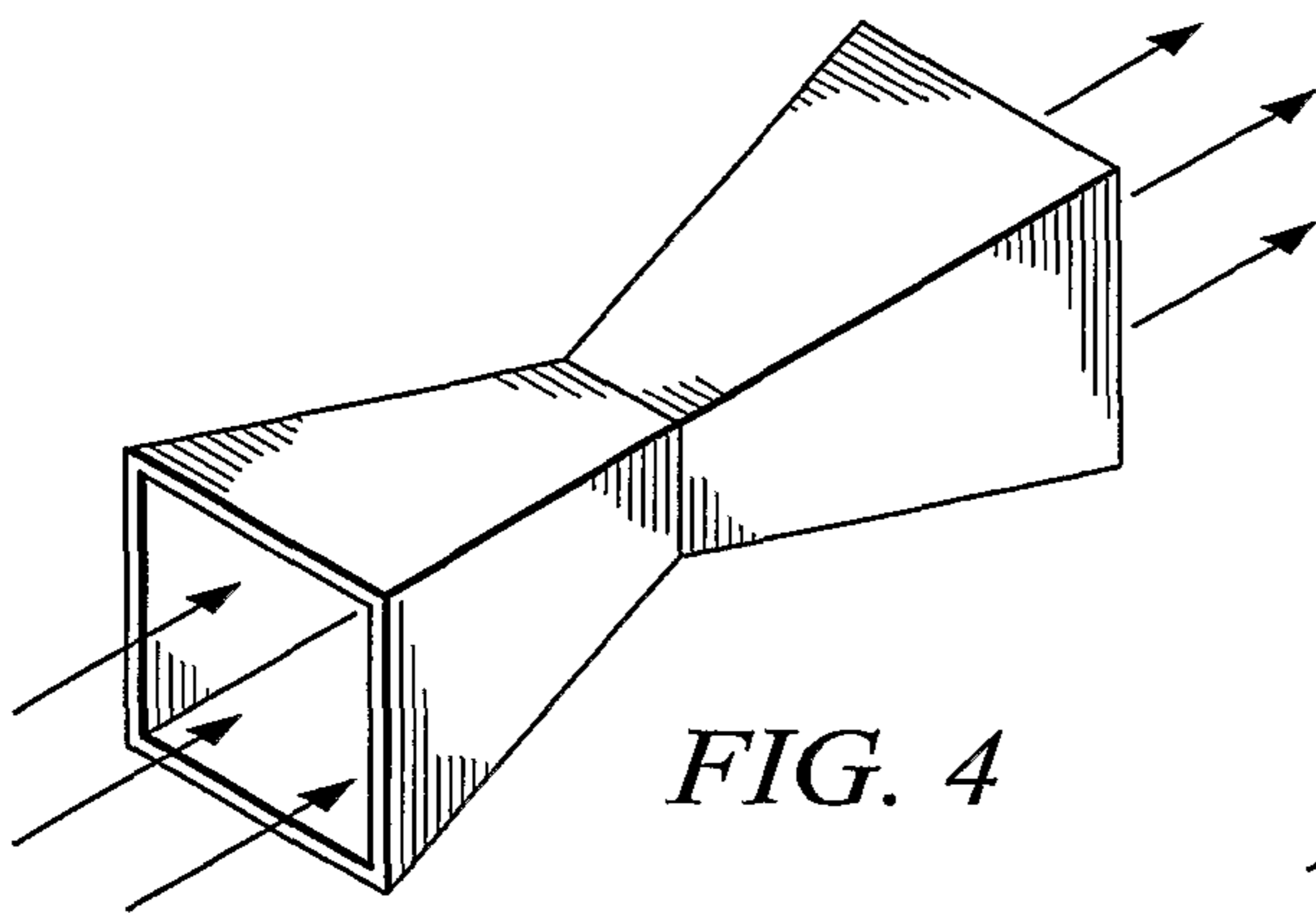

FIG. 4

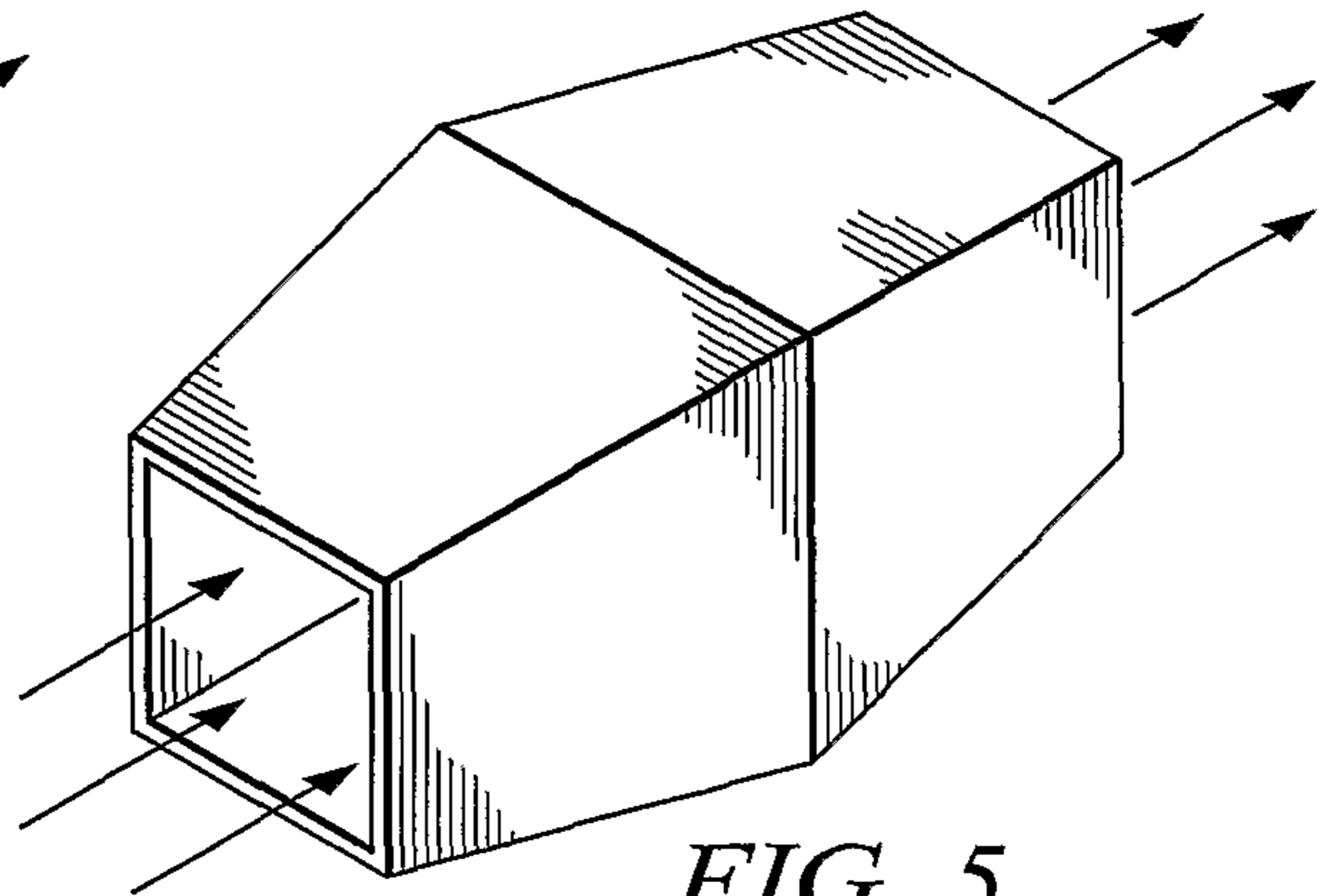

FIG. 5

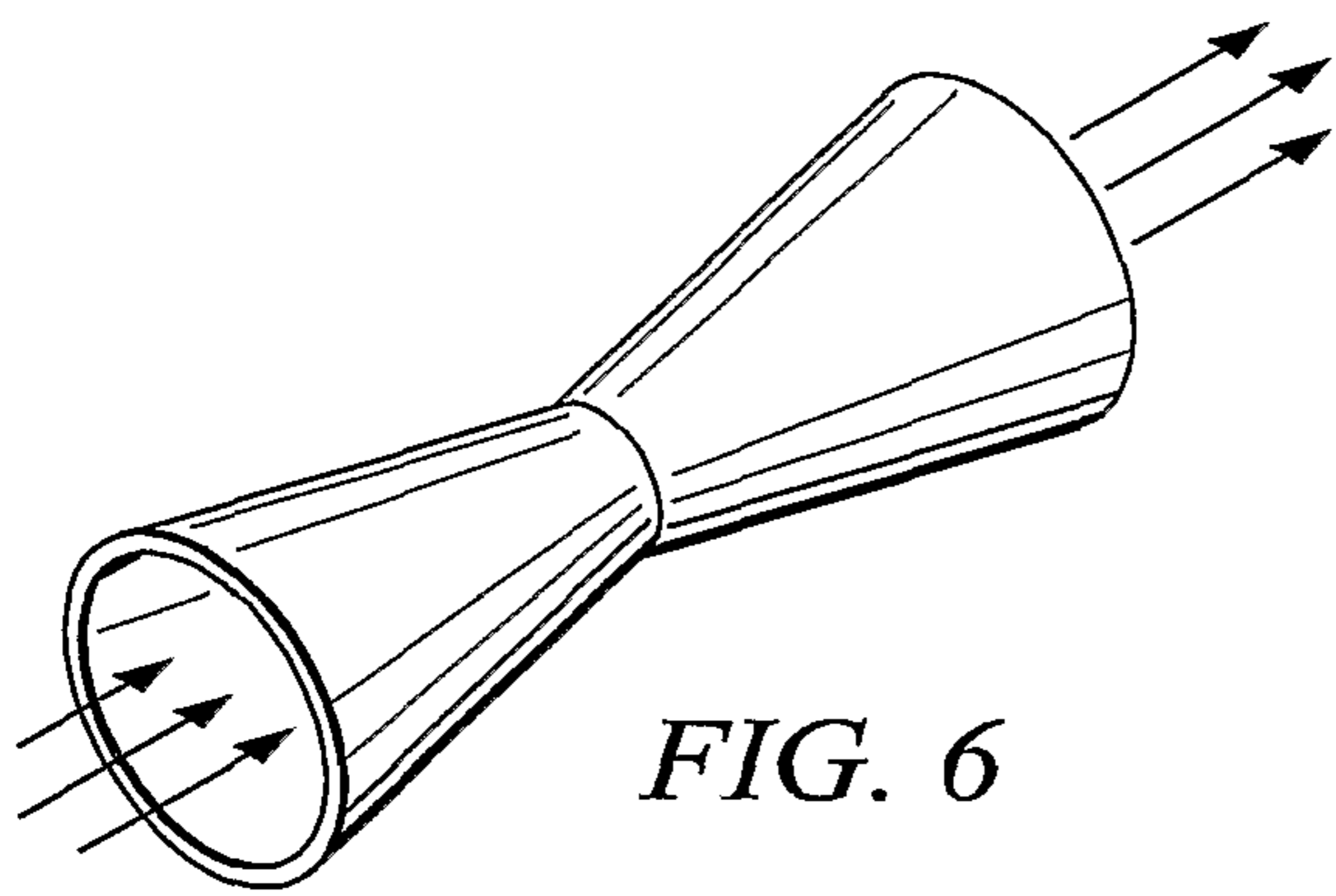

FIG. 6

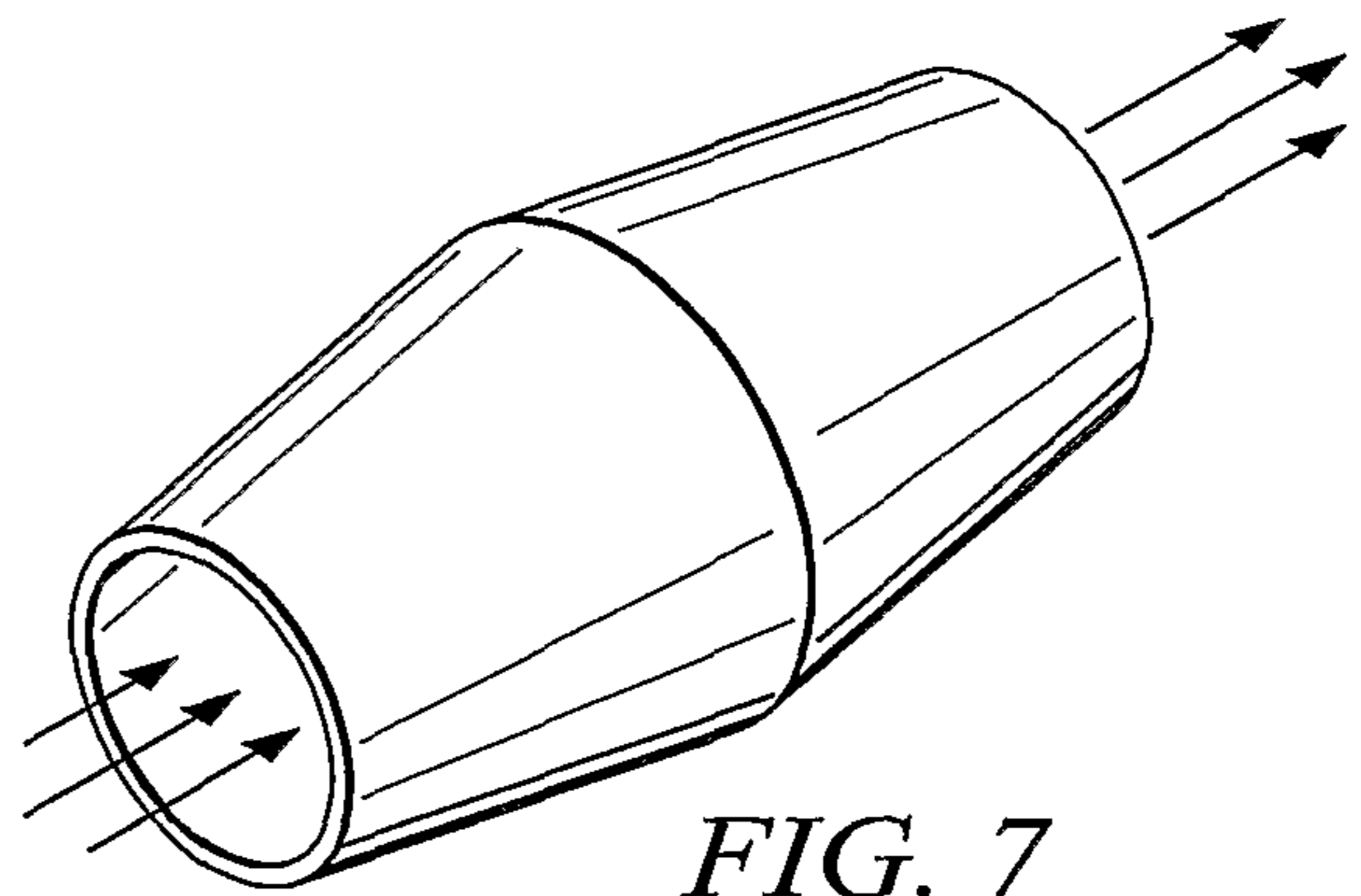

FIG. 7

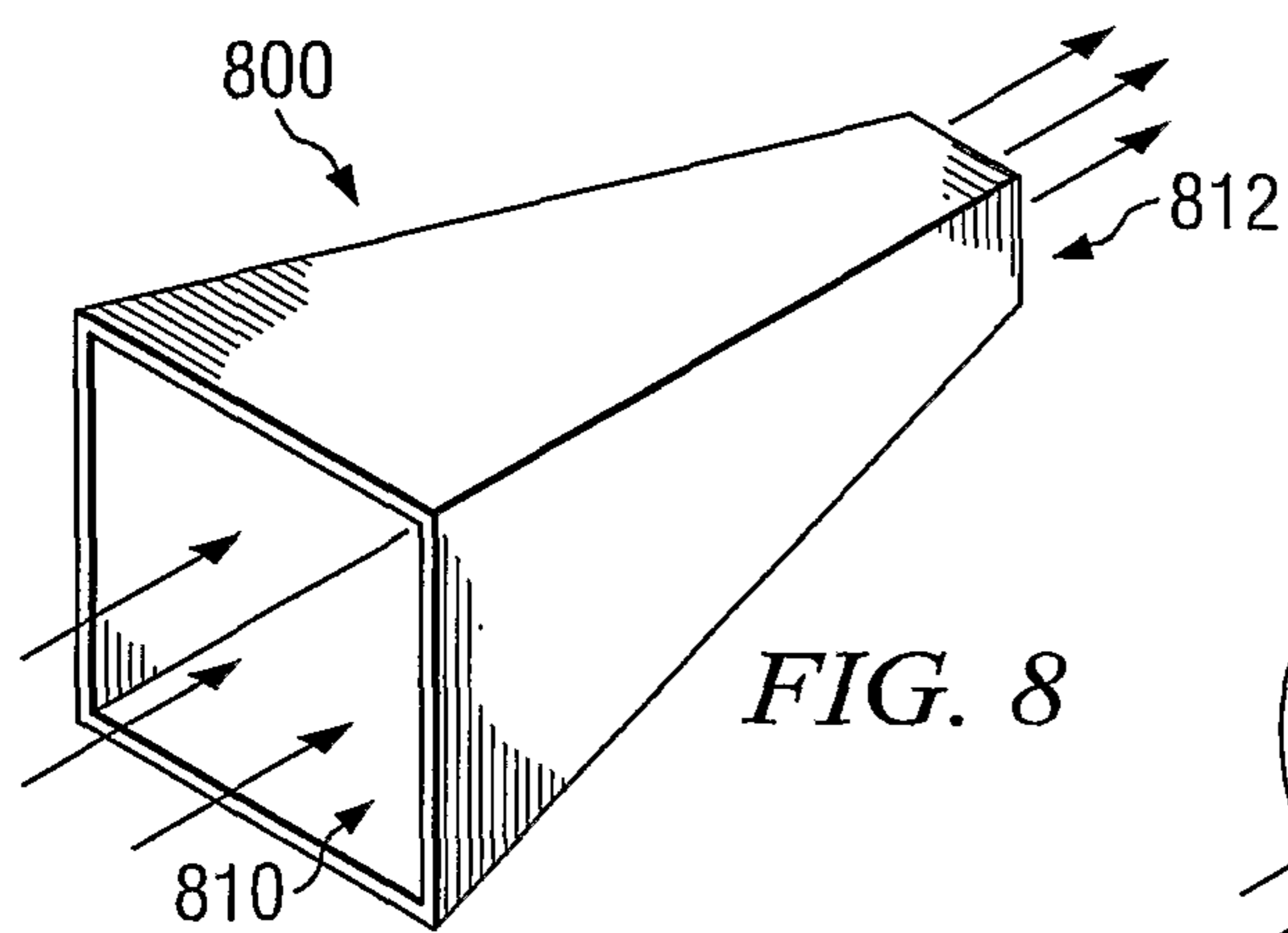

FIG. 8

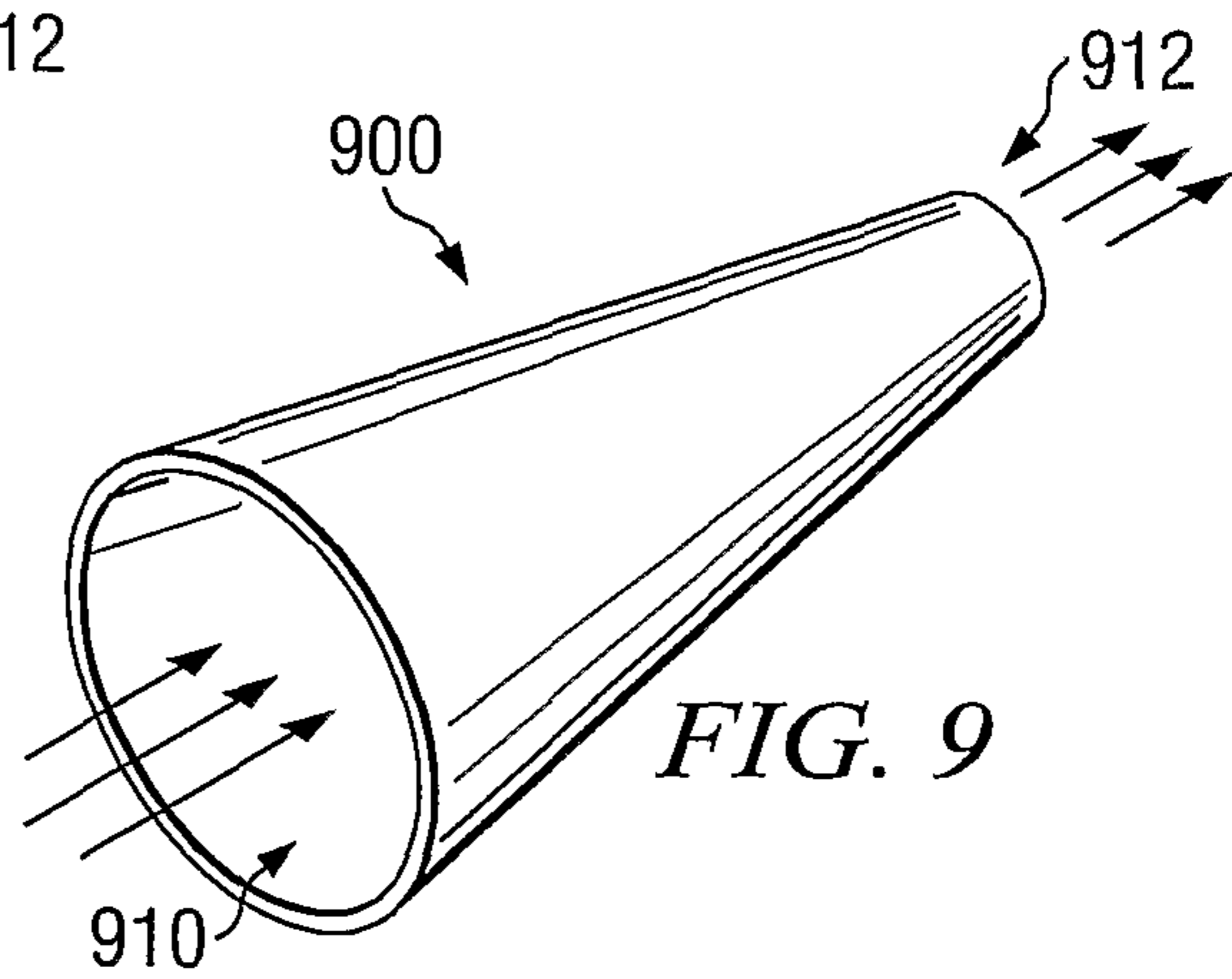
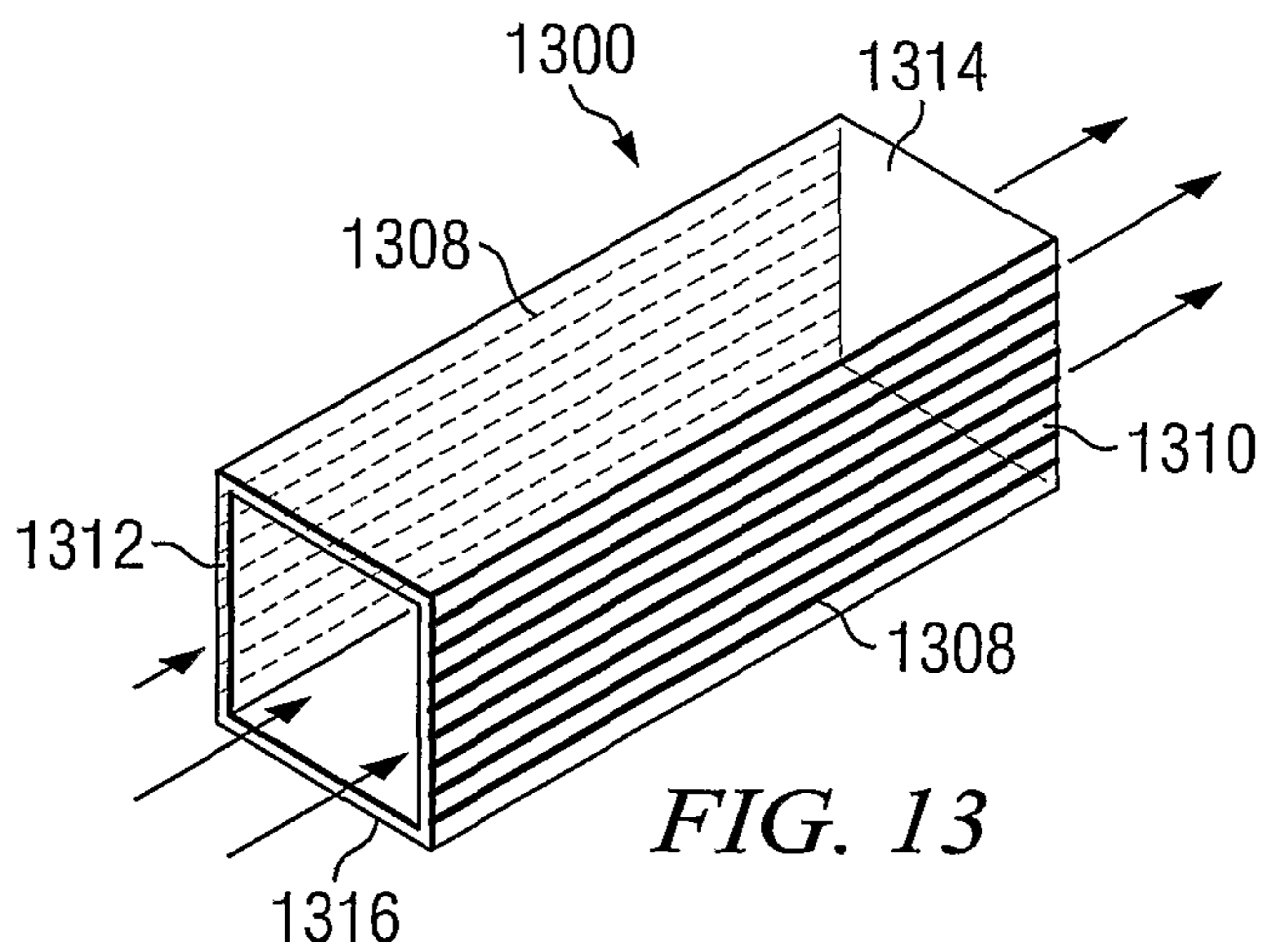
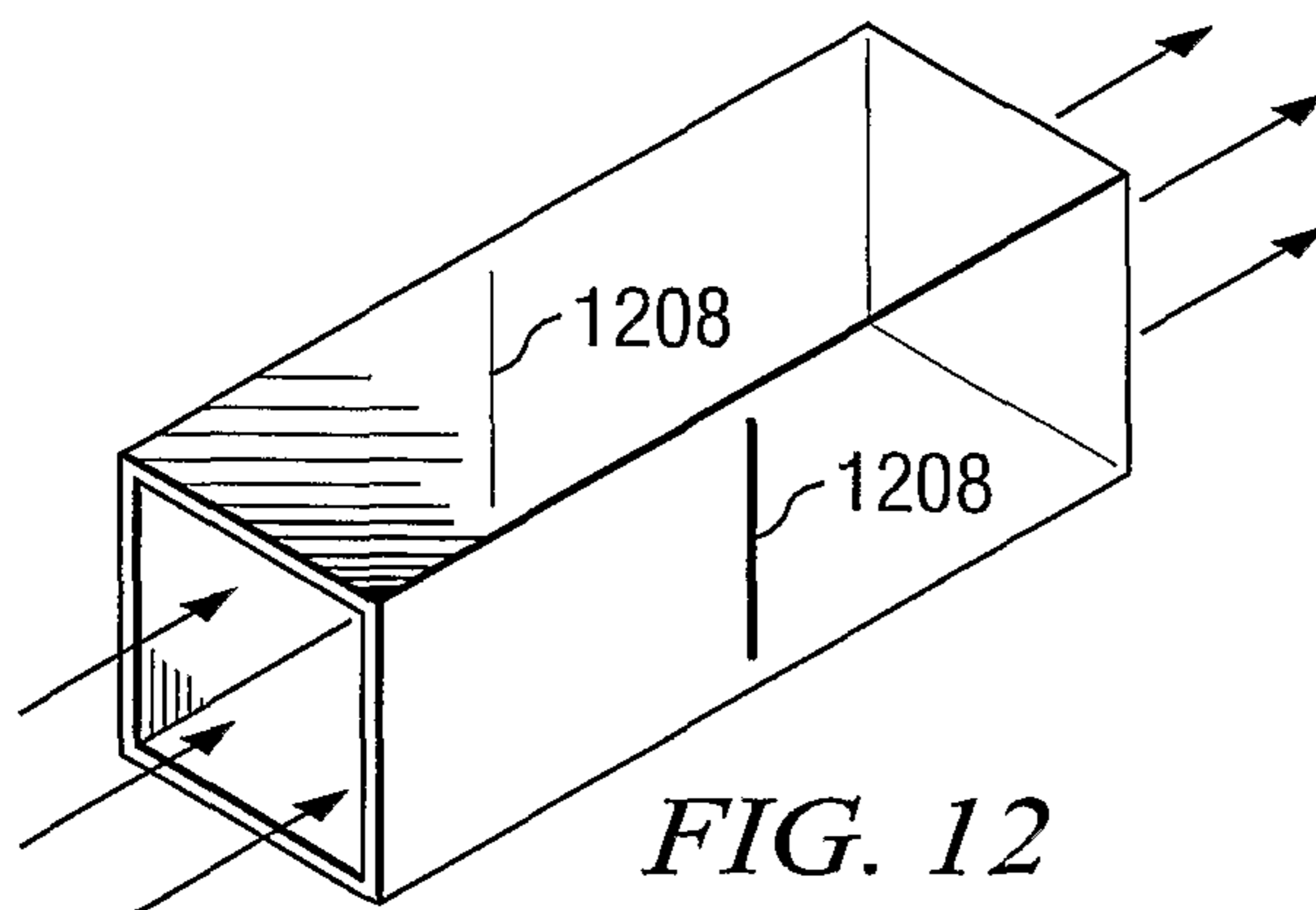
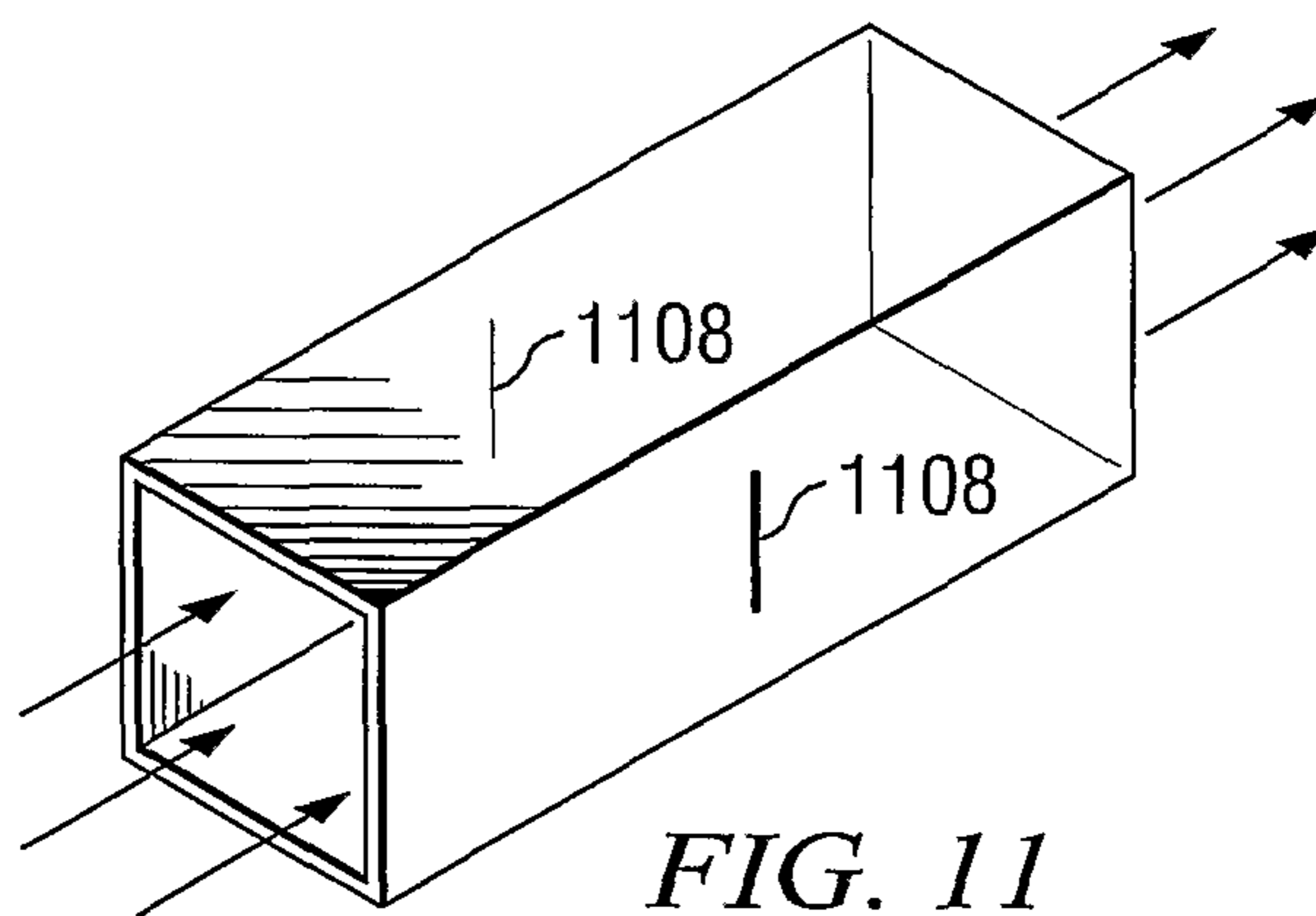
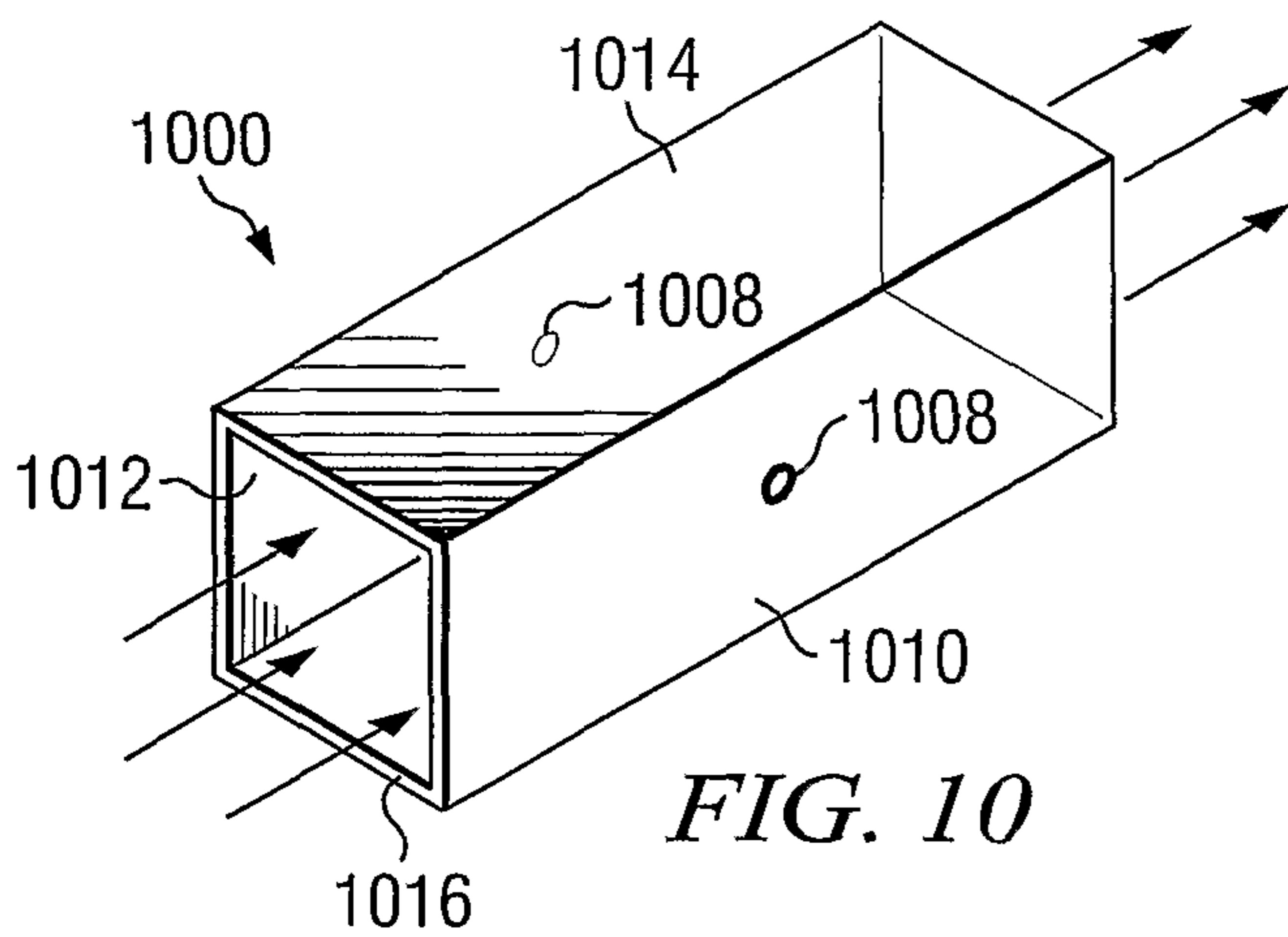

FIG. 9



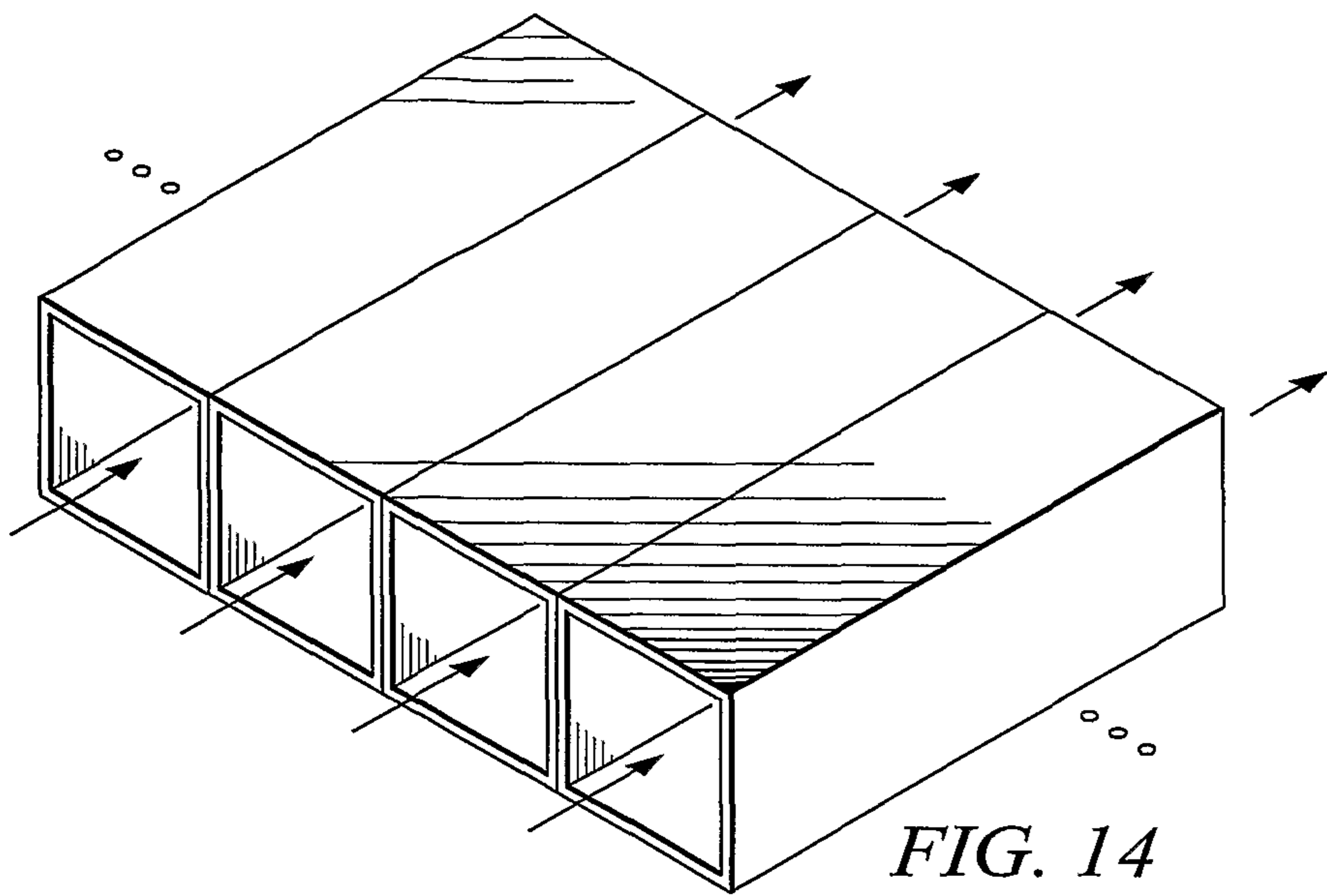

FIG. 14

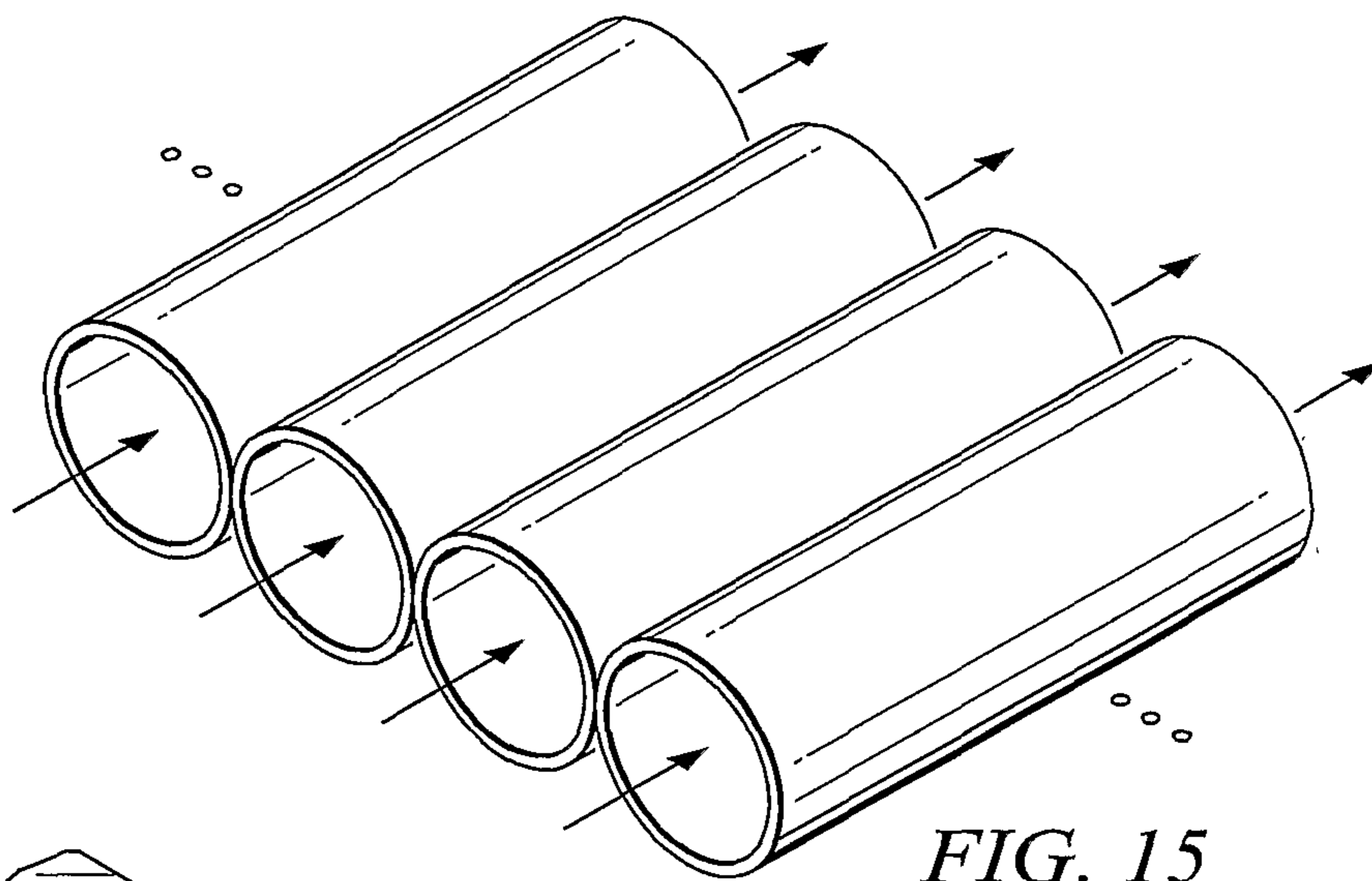

FIG. 15

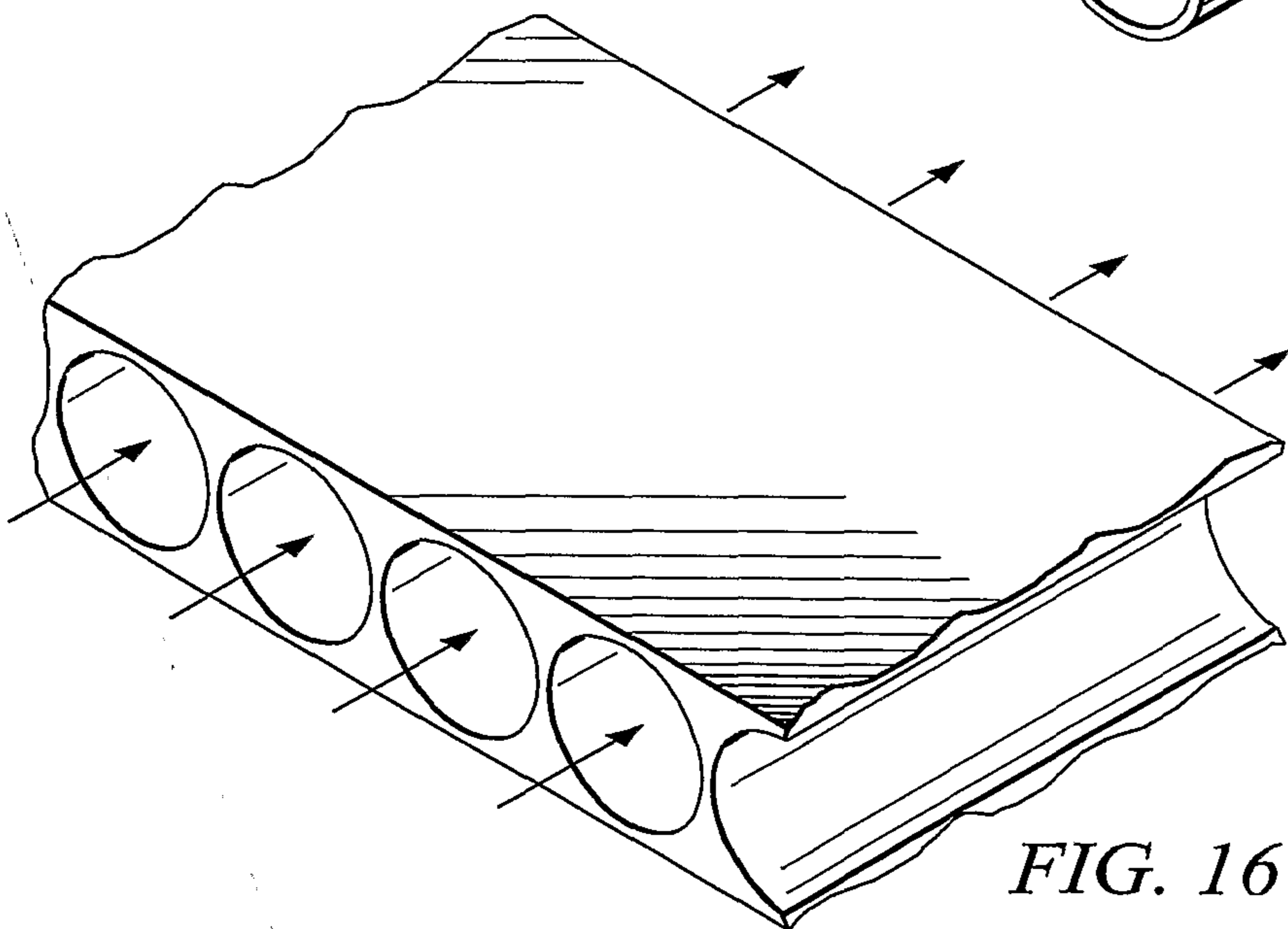

FIG. 16

