



(86) Date de dépôt PCT/PCT Filing Date: 2012/11/08
 (87) Date publication PCT/PCT Publication Date: 2013/05/16
 (45) Date de délivrance/Issue Date: 2021/10/19
 (85) Entrée phase nationale/National Entry: 2014/05/07
 (86) N° demande PCT/PCT Application No.: US 2012/064198
 (87) N° publication PCT/PCT Publication No.: 2013/070946
 (30) Priorité/Priority: 2011/11/08 (US61/557,319)

(51) Cl.Int./Int.Cl. *A61N 5/06* (2006.01)
 (72) Inventeurs/Inventors:
 JOHNSON, PATRICK LAMBERTH, US;
 BUCHANAN, KATHLEEN STANTON, US
 (73) Propriétaire/Owner:
 BIOPHOTAS, INC., US
 (74) Agent: GOWLING WLG (CANADA) LLP

(54) Titre : DISPOSITIF DEFORMABLE DE LUMINOTHERAPIE ET PROCEDE ASSOCIE
 (54) Title: SHAPEABLE LIGHT THERAPY DEVICE AND METHOD

(57) **Abrégé/Abstract:**

Methods, devices and systems for delivering light therapy to human or non-human animal subjects. Included are shapeable light therapy devices which are formable into different shapes suitable for delivery of therapeutic light to different regions of the subject's body and will retain the desired shape without a need for the use of a strap or other shape-retaining apparatus. Also included are light therapy devices that, in at least some modes of operation, deliver light that is not visible to the human eye and which include indicator(s) to indicate to a user and/or to the subject being treated when non-visible light is actually being emitted.

(12) INTERNATIONAL APPLICATION PUBLISHED UNDER THE PATENT COOPERATION TREATY (PCT)

(19) World Intellectual Property
Organization
International Bureau(10) International Publication Number
WO 2013/070946 A2(43) International Publication Date
16 May 2013 (16.05.2013)(51) International Patent Classification:
A61N 5/06 (2006.01)(21) International Application Number:
PCT/US2012/064198(22) International Filing Date:
8 November 2012 (08.11.2012)

(25) Filing Language: English

(26) Publication Language: English

(30) Priority Data:
61/557,319 8 November 2011 (08.11.2011) US(71) Applicant: **BIOPHOTAS, INC.** [US/US]; 250 El Camino
Real # 110, Tustin, CA 92780 (US).(72) Inventors: **JOHNSON, Patrick, Lamberth**; 10212 La Si-
erra Place, Cowan Heights, CA 92705 (US).
BUCHANAN, Kathleen, Stanton; 545 Emerald Bay, La-
guna Beach, CA 92651 (US).(74) Agent: **BUYAN, Robert, D.**; Stout, Uxa, Buyan &
Mullins, LLP., 4 Venture, Suite 300, Irvine, CA 92618
(US).(81) Designated States (*unless otherwise indicated, for every
kind of national protection available*): AE, AG, AL, AM,AO, AT, AU, AZ, BA, BB, BG, BH, BN, BR, BW, BY,
BZ, CA, CH, CL, CN, CO, CR, CU, CZ, DE, DK, DM,
DO, DZ, EC, EE, EG, ES, FI, GB, GD, GE, GH, GM, GT,
HN, HR, HU, ID, IL, IN, IS, JP, KE, KG, KM, KN, KP,
KR, KZ, LA, LC, LK, LR, LS, LT, LU, LY, MA, MD,
ME, MG, MK, MN, MW, MX, MY, MZ, NA, NG, NI,
NO, NZ, OM, PA, PE, PG, PH, PL, PT, QA, RO, RS, RU,
RW, SC, SD, SE, SG, SK, SL, SM, ST, SV, SY, TH, TJ,
TM, TN, TR, TT, TZ, UA, UG, US, UZ, VC, VN, ZA,
ZM, ZW.(84) Designated States (*unless otherwise indicated, for every
kind of regional protection available*): ARIPO (BW, GH,
GM, KE, LR, LS, MW, MZ, NA, RW, SD, SL, SZ, TZ,
UG, ZM, ZW), Eurasian (AM, AZ, BY, KG, KZ, RU, TJ,
TM), European (AL, AT, BE, BG, CH, CY, CZ, DE, DK,
EE, ES, FI, FR, GB, GR, HR, HU, IE, IS, IT, LT, LU, LV,
MC, MK, MT, NL, NO, PL, PT, RO, RS, SE, SI, SK, SM,
TR), OAPI (BF, BJ, CF, CG, CI, CM, GA, GN, GQ, GW,
ML, MR, NE, SN, TD, TG).**Published:**— *without international search report and to be republished
upon receipt of that report (Rule 48.2(g))*

(54) Title: SHAPEABLE LIGHT THERAPY DEVICE AND METHOD

(57) Abstract: Methods, devices and systems for delivering light therapy to human or non-human animal subjects. Included are shapeable light therapy devices which are formable into different shapes suitable for delivery of therapeutic light to different regions of the subject's body and will retain the desired shape without a need for the use of a strap or other shape-retaining apparatus. Also included are light therapy devices that, in at least some modes of operation, deliver light that is not visible to the human eye and which include indicator(s) to indicate to a user and/or to the subject being treated when non-visible light is actually being emitted.



WO 2013/070946 A2

SHAPEABLE LIGHT THERAPY DEVICE AND METHOD

RELATED APPLICATION

[0001] This patent application claims priority to United States Provisional Patent Application No. 61/557,319 entitled Shapeable Light Therapy Device and Method filed November 8, 2011.

FIELD OF THE INVENTION

[0002] The present invention relates generally to the fields of physics, electronics, biology and medicine and more particularly to devices and methods for delivering light therapy to humans or animals.

BACKGROUND

[0003] Light therapy (i.e., "phototherapy"), using various types of light, has been used or proposed for use in a number of cosmetic and therapeutic applications, including but not necessarily limited to improvement of skin elasticity, deterrence of skin aging, treatment of dermatological disorders (e.g., acne, psoriasis), healing of wounds, treatment of jaundice in newborns, and treatment of certain psychological conditions such as seasonal affective disorder (SAD) and certain sleep disorders. In some applications, light therapy is used alone while in others it is used in combination with drugs or agents (e.g., photo-sensitizing agents, photo-activating agents, agents which reduce skin opacity or improve light penetration through or into the skin, etc.). In some forms of light therapy, the subject is positioned in or near a device

called a light therapy box. In other forms of light therapy, a light emitting device is positioned on or near a particular are of the body to be treated.

[0004] One example of a light emitting device that is positionable on or near a particular are of the body to be treated is described in United States Patent Application Publication No. 2011/0144724 (Benedict) entitled *Portable Phototherapy Device and Method for Using a Portable Phototherapy Device*, a copy of which is appended to and forms a portion of United States Provisional patent Application No. 61/557,319, to which this application claims priority.

[0005] Light emitting phototherapy devices of the prior art have not been optimal for all potential applications. For example, at least some light emitting phototherapy devices of the prior art have lacked sufficient flexibility characteristics to allow them to be formed by had into various alternative shapes (e.g., including shapes that have tight radii of curvature and/or complex curvatures) without damaging the device and/or have required the use of a strap or other shape-retaining apparatus to hold the device in a desired shape during use. In general, this lack of formability can result in some or all of the light emitters of the device being positioned at non-optimal distances from the affected body surface during treatment. The development of new light emitting phototherapy devices having improved or different formability may improve the potential efficacy of the phototherapy provided by enabling the device to be pre-formed to a shape that causes many or all of the light emitters on the device to be within a therapeutically optimal distance from the affected body surface.

[0006] Accordingly, there remains a need in the art for the development of new or modified phototherapy devices that incorporate modifications and improvements which render them advantageous over the prior art.

SUMMARY OF THE INVENTION

[0007] The present invention provides new light therapy devices and methods as well as modifications, improvements and additions that may be incorporated into prior light therapy devices, such as those described in United States Patent Application Publication No. 2011/0144724 (Benedict). Additionally, certain aspects, details, attributes and elements of the invention may be understood from the examples shown in accompanying Figures 1-20 and described below.

[0008] In accordance with one aspect of the present invention, there is provided a light therapy device that may be substantially the same as that described in United States Patent Application Publication No. 2011/0144724 (Benedict) but which is capable of being formed into and retaining a desired shape (e.g., a curved or twisted shape) without the need for strap(s) or other restraining apparatus to hold the device in the desired shape. For at least some applications, the improved formability of the devices of the present invention enables such devices to be pre-formed to various shapes to ensure that many or all of the light emitters on the device will be within a therapeutically optimal distance (in some cases -- as close as possible without touching) from the affected body surface. By positioning the light emitters within the therapeutically optimal distance from the body surface, factors such as the depth to which therapeutic wavelength(s) of light penetrate the subject's body.

[0009] In accordance with another aspect of the present invention, there are provided light therapy devices that include light emitters (e.g., LEDs) which emit light at wavelength(s) outside of human visible range (referred to herein as “non-visible light”), wherein the device includes one or more indicator(s) to indicate to a user of the device when the non-visible light is being emitted. For example, a light therapy device of the present invention may include an array of infrared, red and blue LEDs wherein each LED(s) emits light in accordance with one or more programmed light therapy protocols. In such device, one or more indicator LED’s of a different visible color (e.g., green LED(s)) may be included in the array and the device may be programmed to cause such indicator LED(s) to illuminate when the infrared LEDs are emitting non-visible light.

[0010] In accordance with one specific embodiment of the invention, there is provided a system which comprises a) a pad (e.g., panel, sheet, etc.) that is positionable on or near a portion of the body or a human or animal subject and b) at least one light emitter positioned on or in the pad and operative to deliver a light therapy session by casting light from the pad onto or into said portion of the body. At least a portion of the pad is formable into alternative configurations (e.g., curved or twisted configurations) and, when formed into a particular alternative configuration, will retain that alternative configuration during a subsequent light therapy session without the need for straps or other retainer members to hold the device in such alternative configuration. In this manner the device may be custom-formed to a desired configuration at the time of each use. For example, the device may be formed to correspond (e.g., fit upon or have an analogous configuration to) the anatomical shape of the portion of a human or animal’s body to which light therapy is to be

delivered. In some embodiments, substantially the entire pad may be shapeable while in other embodiment(s) only one or more portions of the pad may be shapeable. In some embodiments, the pad may have a plurality of shapeable regions, one or more of which have different forming properties (e.g., flexibility, rigidity, shape memory, elasticity, etc.) than one or more other of shapeable regions. For example, in some embodiments, end regions of the device may be shapeable to more precise or smaller curves than a mid-region of the device. To have the desired formability, the device may be constructed in any suitable manner. For example, in some embodiments substantially the entire pad may be formed of plastically deformable material (e.g., memory material, bendable material, malleable material, shapeable material, etc.). In other embodiments the pad may comprise a composite or layered structure that includes flexible and plastically deformable components or layers, in combination. One non-limiting example of such construction is shown in the accompanying Figures 1-20 and described in detail herebelow.

[0011] In accordance with another aspect of the invention, there is provided a method for delivering light therapy to a human or animal subject. This method generally comprises the steps of: A) causing a device of the foregoing character to be positioned on or near the body of the subject and B) using the device to deliver light to the subject. Step A of this method may include forming of the device to a desired configuration and causing the device to be positioned on or near the body of the subject while it is formed in that desired configuration. As described above, the desired configuration to which the device is formed may correspond to the anatomical shape of the selected body portion to which light therapy is to be delivered. When using an embodiment of the device that is programmed for operation in alternative light

treatment modes, Step B of the method may include selecting the desired light treatment mode in which therapy is to be delivered. When using an embodiment of the device that is programmed to deliver light therapy in either non-modulated (e.g., non-pulsed) or modulated (e.g., pulsed) form, Step B of the method may include selecting either non-modulated or modulated light. The available treatment modes and/or modulation options may be selected for use in treating different pathological or cosmetic conditions and/or for varying the depth of penetration of the desired wavelength(s) of light into the subject's body. Examples of different therapeutic effects that may be achieved by selection of different treatment modes (e.g., red light vs. blue light vs. infrared light) are described in Bartolet, D., *Light-Emitting Diodes (LEDs) in Dermatology*; Seminars in Cutaneous Medicine and Surgery, Vol. 27: pp. 227-238 (2008). Examples of different therapeutic effects that may be achieved by selection of different modulation (e.g., pulsation or non-pulsation) characteristics are described in Bartolet, D., *Importance of Pulsing Illumination Parameters in Low-Level-Light Therapy*; Journal of Biomedical Optics, Vol. 15, No. 4: pp. 048001-048005 (2010).

BRIEF DESCRIPTION OF THE DRAWINGS

[0012] Figure 1 shows one example of a light therapy system comprising a shapeable light therapy device (front view), power source and controller.

[0013] Figure 2 also shows the light therapy system of Figure 1 with a rear view of the shapeable light therapy device.

[0014] Figure 3 shows a sectional view of a portion of the shapeable light therapy device of Figure 1.

[0015] Figure 4 shows a top flexible pad component used in the manufacture of the shapeable light therapy device of Figure 1.

[0016] Figure 5 shows a plastically deformable component used in the manufacture of the shapeable light therapy device of Figure 1.

[0017] Figure 6 shows a flexible circuitry layer component of the light therapy device of Figure 1.

[0018] Figure 7 shows an exploded view of various component layers of the shapeable light therapy device of Figure 1.

[0019] Figure 8 is a rear view of the fully assembled shapeable light therapy device of Figure 1 disposed in a first curved shape.

[0020] Figure 9 is a front view the fully assembled shapeable light therapy device of Figure 1 disposed in the first curved shape.

[0021] Figure 10 is a front view of the fully assembled shapeable light therapy device of Figure 1 disposed in a twisted shape.

[0022] Figure 11 is a front view of the fully assembled shapeable light therapy device of Figure 1 disposed in a second curved shape.

[0023] Figure 12 shows a shapeable light therapy device of the present invention in the first curved shape positioned over the face and neck of a human subject so as to apply light therapy to the subject's face and neck.

[0024] Figure 13 is a schematic of a first portion of an LED array useable in the shapeable light therapy device of Figure 1.

[0025] Figure 14 is a schematic of a second portion of the LED array useable in the shapeable light therapy device of Figure 1.

[0026] Figure 15 is a schematic of a controller circuit board useable in the system of Figure 1.

[0027] Figure 16 is a primary (front) side view of a PCBA of an LED array useable in the shapeable light therapy device of Figure 1

[0028] Figure 17 is a secondary (rear) side view of a PCBA of an LED array useable in the shapeable light therapy device of Figure 1

[0029] Figure 18 is an enlarged sectional/assembly view of region A-A of Figure 17.

[0030] Figure 19 is a primary (front) side view of a PCBA of a controller circuit board usable in the system of Figure 1.

[0031] Figure 20 is a secondary (rear) side view of a PCBA of a controller circuit board usable in the system of Figure 1.

DETAILED DESCRIPTION AND EXAMPLES

[0032] The following detailed description and the accompanying drawings to which it refers are intended to describe some, but not necessarily all, examples or embodiments of the invention. The described embodiments are to be considered in all respects only as illustrative and not restrictive. The contents of this detailed description and the accompanying drawings do not limit the scope of the invention in any way. This example refers to the accompanying Figures 1-20.

[0033] Figures 1 and 2 show one non-limiting example of a system 10 of the present invention. This system 10 includes at least one shapeable pad light emitting apparatus 12, a controller/user interface 14 and a power supply 16. In some applications the controller/user interface 14 may be connected to a single shapeable pad light emitting apparatus 12. In other applications, the controller/user interface 14 may be connected to, and used to simultaneously control, more than one shapeable pad light emitting apparatus 12. Such

simultaneous use of more than one shapeable pad light emitting apparatus 12 may be desirable in instances where more than one area of a subject's body is being treated. In Figure 1, the shapeable pad light emitting apparatus 12 is seen in front view while in Figure 2 a rear view of the shapeable pad light emitting apparatus 12 is shown.

[0034] In general, the power source 16 may be any suitable type of power source. In the particular non-limiting example shown in these drawings, the power source 16 comprises a universal power source that may be plugged into standard wall power outlets in various geographic regions of the world to supply power to the shapeable pad light emitting apparatus 12 and controller/user interface. In the example shown, the shapeable pad light emitting apparatus 12 has a control cable 30 that is adapted to be alternately connected to and disconnected from the controller/user interface 14. In some such embodiments, the controller/user interface 14 may have multiple jacks or connector sites so that it may be connected to, and used to control, more than one shapeable pad light emitting apparatus 12. In other embodiments, the control cable 30 of at least one shapeable pad light emitting apparatus 12 may be permanently connected to the controller/user interface.

[0035] In general, the controller/user interface 14 may comprise a suitable microprocessor, circuit board and user interface which communicates by wired or wireless connection with the shapeable pad light emitting apparatus 12 to provide on/off, mode and pulsation control of the light emitted by the LEDs of the shapeable pad light emitting apparatus 12. In some embodiments, the controller/user interface 14 may be programmed to simultaneously control more than one shapeable pad light emitting apparatus 12 when desired. In the particular non-limiting example shown in the

drawings, the controller/user interface includes an on/or button 14a, a mode selection button 14c, selected mode indicator lights 15, a treatment start button 14b and a pulsation on/pulsation off button 14d. Non-limiting examples of specific electrical circuitry and components usable in this controller/user interface 14 are shown in the schematics and diagrams of Figures 19-20.

[0036] In general, the shapeable pad light emitting apparatus 12 of this example may comprise a number of components affixed in a stacked array as shown in the cross sectional view of Figure 3. These components include a front flexible pad layer 18 having a central aperture 19 formed therein, a plastically deformable (e.g., bendable, malleable, shapeable) layer 20 which also has a central aperture 19 formed therein, at least one flexible circuitry layer 22 having light emitting diodes (LEDs) 23 positioned thereon and a rear flexible pad member 24. Examples of specific electrical circuitry and components usable in the circuitry layer 22 are shown in the schematics and diagrams of Figures 13-18. In the particular non-limiting example shown in Figure 1, the LEDs 23 include a multiplicity of therapeutic light emitting LEDs including infrared, red and blue LEDs as well as one or more indicator LEDs 25 comprising green LEDs which emit light only when the infrared LEDs are illuminated. In this manner, the visible green light emitted by the indicator LEDs signals to the user and/or the subject being treated when the non-visible infrared LEDs are emitting therapeutic light.

[0037] As may be appreciated from the cross-sectional view of Figure 3, in some embodiments, the front flexible pad member 18 may be formed of two layers of flexible plastic foam 18a and 18b, in juxtaposition to one another. These components affixed to one another in a stacked array such that light emitted by the LEDs will pass through the central aperture of the front flexible

pad layer 18. A translucent shield or barrier 26 may extend over the front of the flexible circuitry layer 22 thereby preventing the LEDs and any other electronic components on the front side of the flexible circuitry layer 22 from directly contacting objects or body surfaces and/or to allow hygienic cleansing of the device, while allowing the emitted light to pass through the translucent shield or barrier 26. Optionally, in some embodiments, all or just a portion (e.g., a peel off front surface film layer) of the translucent shield or barrier 26 may be disposable and/or replaceable between uses of the device 10.

[0038] The flexible circuitry layer 22 may comprise one or more flexible circuit boards. Specifically, in this example, the flexible circuitry layer 22 may comprise a flexible printed circuit board having the LEDs and possibly other components such as resistors. A second printed circuit board comprising firmware embedded in microprocessor logic circuitry may be housed in the user interface 14 or any other component connected to the device 10. Also, in this example, the LEDs comprise infrared, red and blue LEDs which, respectively, deliver infrared light having a wavelength of, or of about, 880nm; red light having a wavelength of, or of about, 640nm or blue light having a wavelength of, or of about, 465nm.

[0039] As seen in Figure 7, a control cable 30 is connected to the flexible circuitry layer 22. Such control cable 30 may extend through a passage channel 32 formed in the rear layer 18a of the front flexible pad member 18. The front layer 18b may then be placed over top of the rear layer 18a to encase the control cable 30 within the channel 32.

[0040] As seen in Figure 5, in this example, the plastically deformable layer 20 is formed of a plastically deformable material (e.g., aluminum or other suitable metal, deformable memory plastic, etc.) that is flexible enough to be

deformed to a desired configuration by hand while also having sufficient shape memory to retain the configuration to which it has been deformed during subsequent use of the device for delivery of a light therapy session. This metal sheet has end regions with perforations 21 formed therein and a non-perforated mid-region on either side of the central aperture 19. The size, number and spacing of the perforations 21 controls the forming properties (e.g., flexibility, rigidity, shape memory, elasticity, etc.) of the end regions and lessens the amount of force required to change the shape of those regions, thereby enabling a user to hand-shape the device as desired. For example, these perforations 21 in the plastically deformable layer 20 may render the end regions of the device 10 shapeable to curved shapes that have tighter or different radii of curvature than would be possible if such perforations 21 were not present. In this manner, regionalized perforations 21 are used to control the relative deformability and memory of various regions of the device 10. In this example, the perforations 21 allow the ends of the device 10 to be bent to form "feet" at either end of the device so that when the mid-region of the device is curved, the device will form an arch-like structure at a desired height over an underlying surface and/or body part. Also, in this example, the perforations 21 allow the use of a metal sheet that sufficiently thick enough to impart the desired structural integrity and forming properties to the relatively narrow portions on either side of the central aperture 19 in the mid-region, without causing the end regions to be too stiff or too difficult to bend or form to the desired shape(s).

[0041] Figures 8 through 12 show several non-limiting examples of shapes that the shapeable pad light emitting apparatus 12 may be formed to and which the apparatus 12 will retain without the need for a strap or other

retaining device. As illustrated in Figure 12, the ability to place the apparatus 12 in various formed shapes allows it to be positioned so that it corresponds to (e.g., conforms to or tracks the shape of) the underlying area of the body to be treated (e.g., face, thigh, neck, etc.). Thus, for many common applications, the apparatus 12 may be hand-shaped to a configuration that allows it to be positioned over the body part to be treated with the therapeutic LEDs located as close as possible to the skin without the apparatus 12 actually touching the skin. Also, in some applications, this allows the ends of the apparatus 12 to be shaped so that the apparatus 12 may be stood upon an underlying surface (e.g., the surface of the bed or treatment table on which the subject is positioned) while the therapeutic LEDs are optimally positioned to deliver the desired phototherapy treatment.

[0042] In this example, the device 10 is programmed to deliver light therapy in a plurality of alternative light treatment modes intended for different therapeutic or cosmetic applications, including a) one light treatment mode wherein the emitted light is primarily infrared; b) another light treatment mode wherein the emitted light is primarily red; and c) yet another light treatment mode wherein the emitted light is primarily blue. Operation of the device 10 in the infrared treatment mode may cause the LEDs to emit light having a wavelength of, or of about, 880nm. Operation of the device 10 in the red treatment mode may cause the LEDs to emit light having a wavelength of, or of about, 640nm. Operation of the device 10 in the blue treatment mode may cause the LEDs to emit light having a wavelength of, or of about, 465nm. As explained above, these different treatment modes may be selected depending on the pathological or cosmetic condition being treated and/or the depth of light penetration desired. See, Bartolet, D., *Light-Emitting Diodes (LEDs) in*

Dermatology; Seminars in Cutaneous Medicine and Surgery, Vol. 27: pp. 227-238 (2008).

[0043] The user interface 14 may include a switch for turning the power on/off and a selector for selecting which treatment mode is desired. Also, optionally, the treatment times may be fixed or the user interface may include a timer set for setting the desired treatment time. Also, optionally, the device may be programmed to emit light in each treatment mode in either a pulsed (e.g., modulated) or non-pulsed fashion and the user interface may include a switch or function to allow the user to select or not select whether pulsing (e.g., modulation) is desired. For example, the device 10 may be set to default to a pulsed delivery of light in each treatment mode unless the user inputs a signal through the user interface 14 to terminate the pulsing. More specifically, in this non-limiting example, when a light therapy session is initiated with the device set in the one treatment mode, the blue LEDs will emit blue light at a 1% duty cycle and the red and infrared LEDs will fade up from 1% to 90% in 20 seconds. When a light therapy session is initiated with the device set in another treatment mode, the blue LEDs will fade up from 1% to 90% in 20 seconds and the red and infrared LEDs will fade up from 1.3% to 2.5% in 2.5 seconds. Also, when a light therapy session is initiated with the device set in yet another treatment mode, the blue LEDs will fade up from 1% to 90% in 20 seconds and the red and infrared LEDs will cycle from 30% to 80% in 11.5 seconds. In this particular non-limiting example, each treatment mode will deliver pulsed light unless pulsation is turned off via the user interface 14, as follows: a) the first light treatment mode will deliver light at a pulse width modulation frequency of about 680Hz unless pulse width modulation is turned off via the user interface 14; b) the second light treatment

mode delivers light at a pulse width modulation frequency of about 800Hz unless pulse width modulation is turned off via the user interface 14 and the third light treatment mode delivers light at a pulse width modulation frequency of about 80Hz unless pulse width modulation is turned off via the user interface 14. As explained above, this ability to select the desired modulation (e.g., pulsation or non-pulsation) allowed the system 10 to be used to achieve different therapeutic effects. See, Bartolet, D., *Importance of Pulsing Illumination Parameters in Low-Level-Light Therapy*; Journal of Biomedical Optics, Vol. 15, No. 4: pp. 048001-048005 (2010).

[0044] In the particular example shown, the controller/user interface 14 includes indicator lights 15 for each of the available therapeutic modes for which the controller is programmed to perform (acne, anti-aging, aches & pains). When the on-off button 14a has been depressed to turn the system on, the controller initially defaults to a first mode (e.g., acne) and the indicator light for that mode begins to blink. If the user wishes to operate in that first mode, the user then presses the start button 14b which causes the first mode indicator light to stop blinking and remain on continually and also causes the therapeutic LEDs to begin to emit light in the selected first treatment mode. If the user wishes to operate in a treatment mode other than the first treatment mode, the user will push the treatment mode selector button 14c the appropriate number of times (i.e., once to shift to the second mode (anti-aging) and twice to shift the third mode (aches & pains), while the indicator light is still blinking. After the desired treatment mode is selected, the user will depress the start button and the system 10 will proceed to deliver therapy in the selected treatment mode, as will be indicated by non-blinking, constant illumination of the selected treatment mode indicator light.

[0045] Pressing the pulsation on/pulsation off button 14d will cause the light emitted by the therapeutic LEDs 23 to pulsate. Pressing the pulsation on/pulsation off button 14d again will cause the light emitted by the therapeutic LEDs 23 to be continuous (i.e., non-pulsating).

[0046] In some embodiments the controller/user interface 14 may include a display. Such display may display indications of whether the power is on or off and what light treatment mode has been selected. Optionally, such display may also display a treatment time that has been selected and/or elapsed and/or remaining; and, optionally, whether pulse width modulation is on or off.

[0047] It is to be appreciated that, although the invention has been described hereabove with reference to certain examples or embodiments of the invention, various additions, deletions, alterations and modifications may be made to those described examples and embodiments without departing from the intended spirit and scope of the invention. For example, any elements, steps, members, components, compositions, reactants, parts or portions of one embodiment or example may be incorporated into or used with another embodiment or example, unless otherwise specified or unless doing so would render that embodiment or example unsuitable for its intended use. Also, where the steps of a method or process have been described or listed in a particular order, the order of such steps may be changed unless otherwise specified or unless doing so would render the method or process unsuitable for its intended purpose. Additionally, the elements, steps, members, components, compositions, reactants, parts or portions of any invention or example described herein may optionally exist or be utilized in the substantial absence of other elements, steps, members, components, compositions, reactants, parts or portions unless otherwise noted. All reasonable additions,

deletions, modifications and alterations are to be considered equivalents of the described examples and embodiments and are to be included within the scope of the following claims.

CLAIMS

What is claimed is:

1. A light therapy device comprising:
 - 5 a light emitting pad that is alternately shapeable into a plurality of retained configurations so as to be positionable adjacent to different body portions of a human or animal subject;
 - 10 a plurality of light emitters comprising i) blue LEDs which emit blue light at wavelength of approximately 465 nm, ii) red LEDs which emit red light at a wavelength approximately 640 nm, iii) infrared LEDs which emit invisible infrared light at a wavelength approximately 880 nm and iv) a visible indicator light which indicates when invisible infrared light, is being emitted from the infrared LEDs, wherein the blue, red and infrared light emitters are positioned on or in the pad and operative to deliver preprogrammed light therapy sessions by casting light from the pad onto
15 or into a body portion adjacent to which the pad is positioned;
 - 20 a controller programmed to cause the light emitters to alternately deliver user-selected preprogrammed light therapy sessions which include at least; i) a light therapy session wherein the emitted light is primarily blue; ii) a light therapy session wherein the emitted light is primarily red; and iii) a light therapy session wherein the emitted light is primarily invisible infrared and wherein the visible indicator light is illuminated; and
 - 25 a user interface in communication with the controller whereby a user may select which of the preprogrammed light therapy sessions is to be delivered and whether the light is to be pulsed or non-pulsed;
 - 30 wherein at least a portion of the pad comprises a pressure deformable shape-retaining member of a material which has shape retention properties so that, as the pad is shaped into one of a plurality of alternative configurations, the pressure deformable shape-retaining member retains the pad in that alternative configuration during a subsequent light therapy session without the need for a strap or other restraining apparatus.

2. A device according to claim 1 wherein less than the entire pad is shapeable.
3. A device according to claim 1 wherein the device has end regions wherein the pad is shapeable to alternative curved shapes and a mid-region wherein the pad is shapeable to alternative curve shapes, and wherein the end regions are shapeable to curved shapes that have tighter or different radii of curvature than curved shapes to which the mid-region is shapeable.
- 5 4. A device according to claim 1 wherein the light emitting pad has a plurality of layers which comprise:
 - a front flexible pad layer having a central aperture formed therein;
 - 10 the pressure deformable shape-retaining member comprising a shape retaining pad layer formed of said material and having a central aperture formed therein;
 - at least one flexible circuitry layer having at least one light emitter positioned thereon; and
 - 15 a rear flexible pad member;
 - the front flexible pad member, shape retaining pad layer, at least one flexible circuitry layer and rear flexible pad layer being affixed to one another in a stacked array such that light emitter by the at least one light emitter passes through the central aperture of the front flexible pad layer.
- 20 5. A device according to claim 1 wherein at least one light emitter comprises a plurality of LEDs on a flexible printed circuit board.
6. A device according to claim 1 wherein the user interface comprises a printed circuit board having firmware embedded in microprocessor logic circuitry.
7. A device according to claim 1 wherein the pressure deformable shape-retaining member comprises a metal.
- 25 8. A device according to claim 1 wherein the user interface is adapted to receive user input for controlling: a) power on/off, and b) selection of desired light treatment mode.

9. A device according to claim 8, wherein the user interface is further adapted to receive user input for controlling: c) pulsation on/off.
10. A device according to claim 8 or claim 9, wherein the user interface is further adapted to receive user input for controlling: d) time duration of light therapy session.
- 5
11. A device according to claim 1 wherein the preprogrammed light session include:
- a light therapy session wherein the blue LEDs will emit blue light at a 1% duty cycle and the red and infrared LEDs will fade up from 1% to 90% in 20 seconds;
- 10
- a light therapy session wherein the blue LEDs will fade up from 1% to 90% in 20 seconds and the red and infrared LEDs will fade up from 1.3% to 2.5% in 2.5 seconds; and
- a light therapy session wherein the blue LEDs will fade up from 1% to 90% in 20 seconds and the red and infrared LEDs will cycle from 30% to 80% in 11.5 seconds.
- 15
12. A device according to claim 1 wherein pulsed light is delivered at a pulse width modulation frequency of approximately 680 Hz.
13. A device according to claim 1 wherein pulsed light is delivered at a pulse width modulation frequency of approximately 800 Hz.
- 20
14. A device according to claim 1 wherein pulsed light is delivered at a pulse width modulation frequency of approximately 80 Hz.
15. A device according to claim 1 wherein a body-contacting portion of the device is disposable or replaceable.
- 25
16. A device according to claim 1 wherein the indicator comprises at least one additional light emitter that emits indicator light of a color other than red or blue when infrared light is being emitted by the infrared light emitters.

17. A device according to claim 1 wherein the controller and user interface are connectable to, and useable to control, a plurality of light emitting pads.
18. Use of the light therapy device according to any one of claims 1 to 17 for delivering light therapy to the human or animal subject.
- 5 19. A method for arranging a light therapy device with respect to a human or animal subject for delivering light therapy, said method comprising the steps of:
- 10 A) obtaining the light therapy device comprising a light emitting pad which comprises a plastically deformable member and a flexible circuitry layer which comprises a multiplicity of therapeutic light emitters, including light emitters of differing wavelengths, positioned so as to cast therapeutic light from a light emitting region on one side of the pad, said pad being alternately shapeable into a plurality of retained configurations which correspond to the shape of different body portions of the human or animal subject and wherein the flexible circuitry layer flexes while the plastically deformable member deforms, thereby enabling the pad to be alternately formed into said plurality of retained configurations and to be retained in such configuration due to plastic deformation of the deformable member; and
- 15
- 20 B) shaping the light emitting pad into a desired retained configuration which corresponds to the shape of a body part to be treated, wherein said shaping of the pad to the desired retained configuration causes the flexible circuitry layer flexes while the plastically deformable member deforms; and
- 25 C) causing the pad, while in said desired retained configuration, to be positioned such that the light emitting region is adjacent to the body part to be treated;
- 30 wherein, the light therapy device is useable to deliver plurality of alternative light treatment modes, including at least one mode wherein nonvisible light is delivered from certain ones of the therapeutic light emitters and an indicator which indicates when nonvisible light is being emitted;

5 wherein the indicator comprises at least one indicator light emitter positioned on the same side of the pad as the light emitting region so as to be visible concurrently with the array of therapeutic light emitters, wherein said at least one indicator light emitter emits, at times when nonvisible light is being emitted by certain ones of the therapeutic light emitters, visible indicator light that is visually distinguishable from visible therapeutic light emitted by the therapeutic light emitters; and

10 wherein the method is performed without a strap or other retaining apparatus being required to hold the light emitting pad in the retained configuration which corresponds to the shape of the body part to be treated.

20. A method according to claim 19 wherein the retained configuration allows the light emitting pad to be positioned a spaced-distance away from the skin of the body part to be treated without directly contacting the skin.

15 21. A method according to claim 19 wherein the device further comprises a controller having a user interface, said controller being programmed to cause the device to deliver light therapy according to whichever of the alternative light treatment modes that a user selects via the user interface.

22. A method according to claim 21 wherein the plurality of alternative light treatment modes from which the user selects comprise:
20 one light treatment mode wherein the emitted light is primarily blue;
another light treatment mode wherein the emitted light is primarily red; and
yet another light treatment mode wherein the emitted light is primarily infrared.

23. A method according to claim 22 wherein the infrared light has a wavelength of, or of approximately 880nm.

25 24. A method according to claim 22 wherein the red light has a wavelength of, or of approximately 640nm.

25. A method according to claim 22 wherein the blue light has a wavelength of, or of about, 465nm.

26. A method according to claim 19 wherein the device is adapted to deliver light therapy using either non-modulated or modulated light and wherein the method further comprises the step of selecting either non-modulated or modulated light.
- 5 27. A method according to claim 19 wherein a portion of the device is removable or replaceable and wherein the method further comprises removing or replacing the removable or replaceable portion prior to performance of Step A.
- 10 28. A method according to claim 27 wherein the device is placed in contact with the subject's body and the removable or replaceable portion of the device comprises a body-contacting portion of the device.
29. A method according to claim 19 wherein the controller/user interface is connected to and used to control a single light therapy device.
- 15 30. A method according to claim 19 wherein the controller/user interface is connected to and used to control a plurality of light therapy devices.
31. A method according to claim 30 wherein the light therapy devices are positioned to allow for simultaneously delivering light therapy to a plurality of locations on a subject's body.
- 20 32. A method according to claim 19 wherein the body part to be treated comprises the face.
33. A method according to claim 19 wherein the body part to be treated comprises the neck.
34. A method according to claim 19 wherein the body part to be treated comprises a limb.
- 25 35. A method according to claim 19 wherein the body part to be treated comprises the torso.

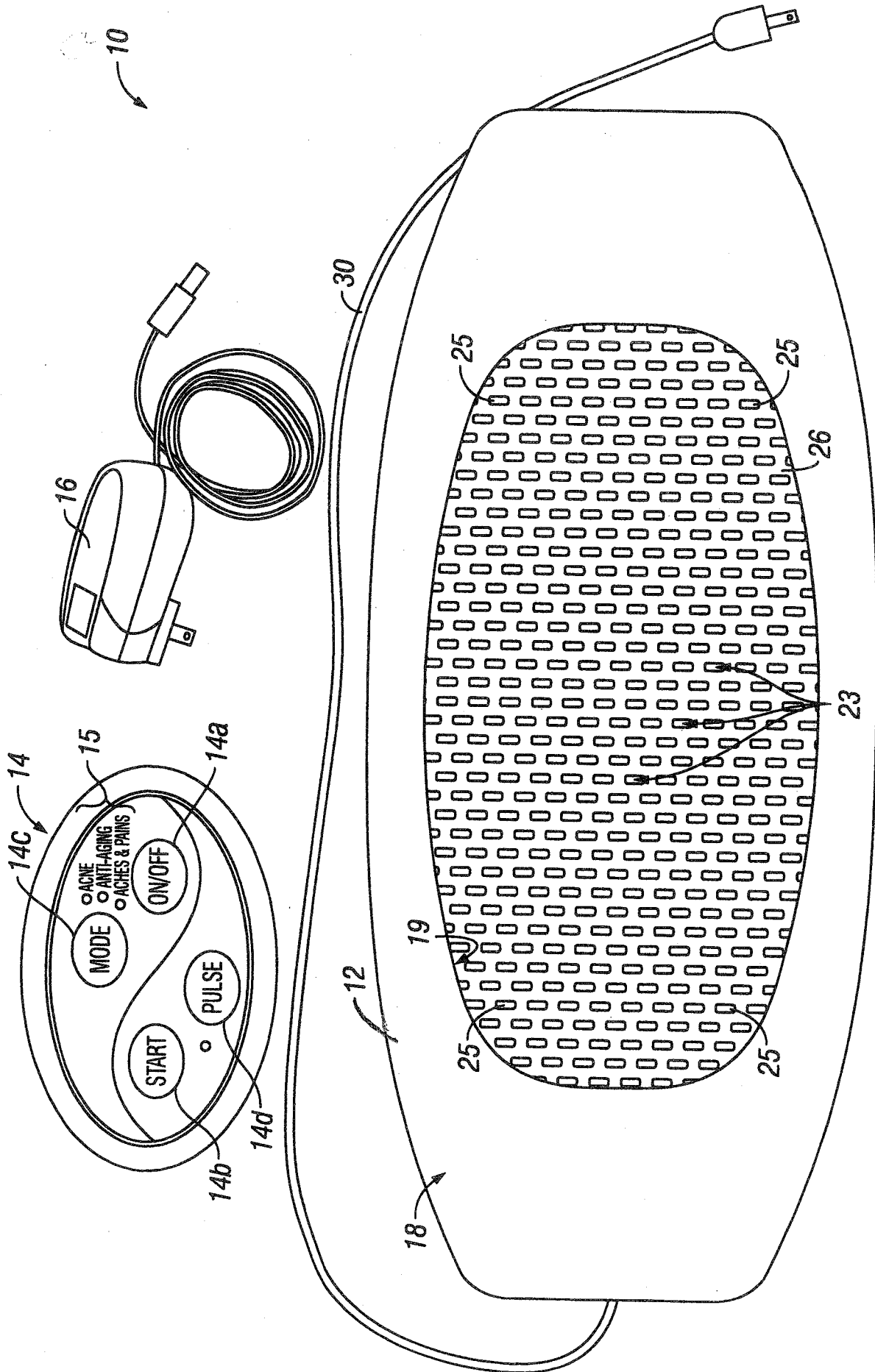

FIG. 1

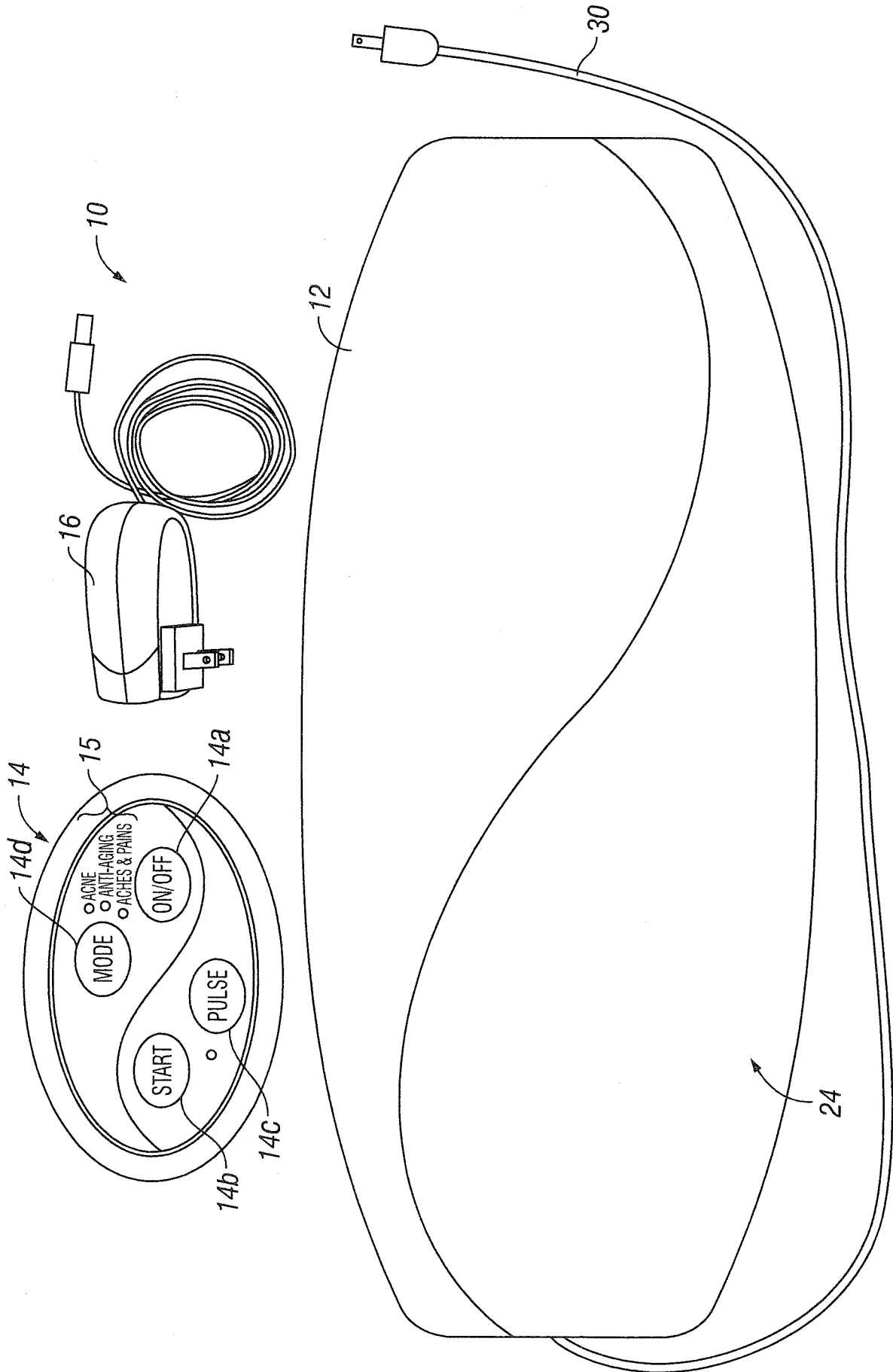

FIG. 2

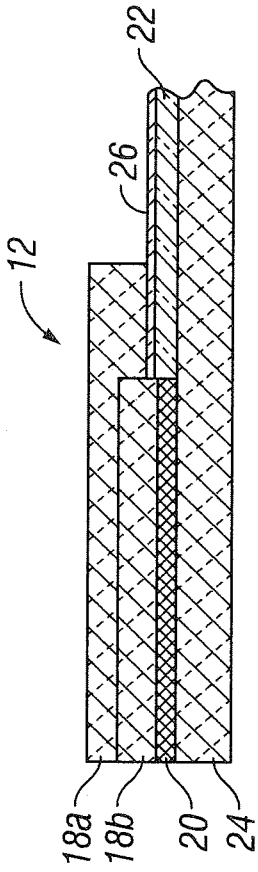

FIG. 3

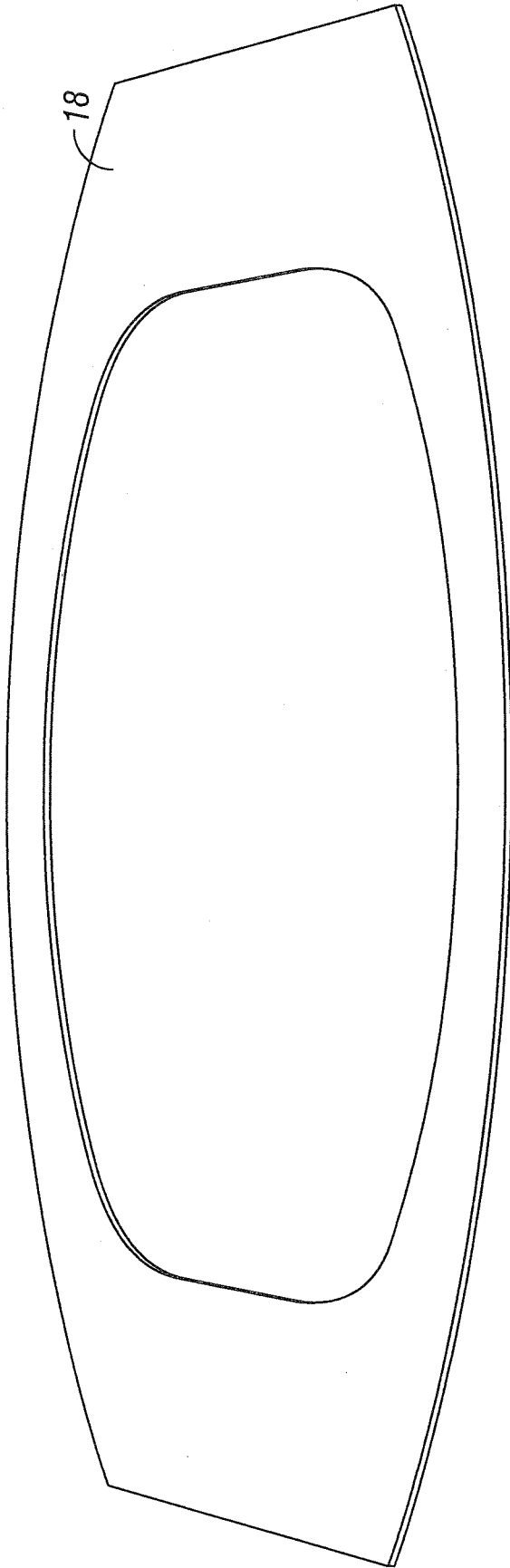

FIG. 4

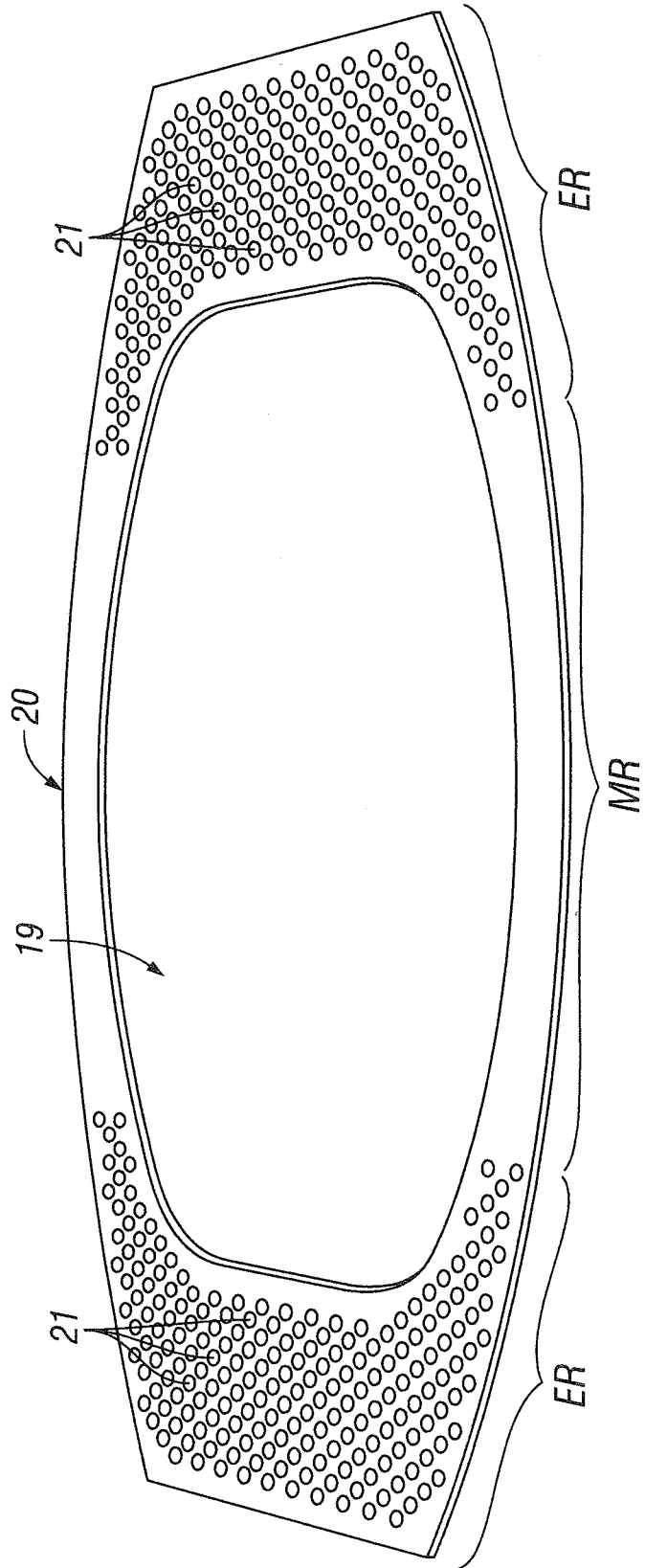

FIG. 5

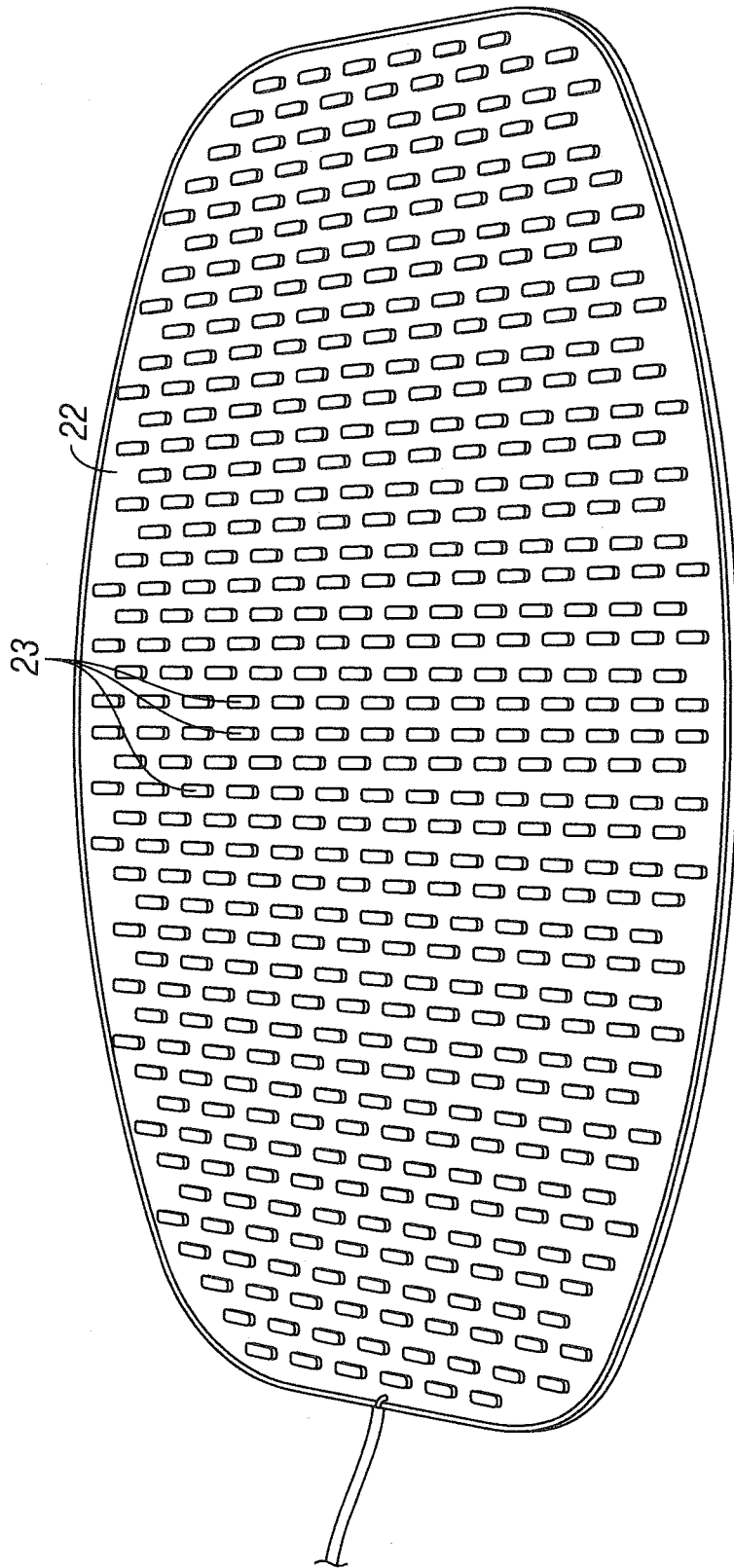

FIG. 6

6/17

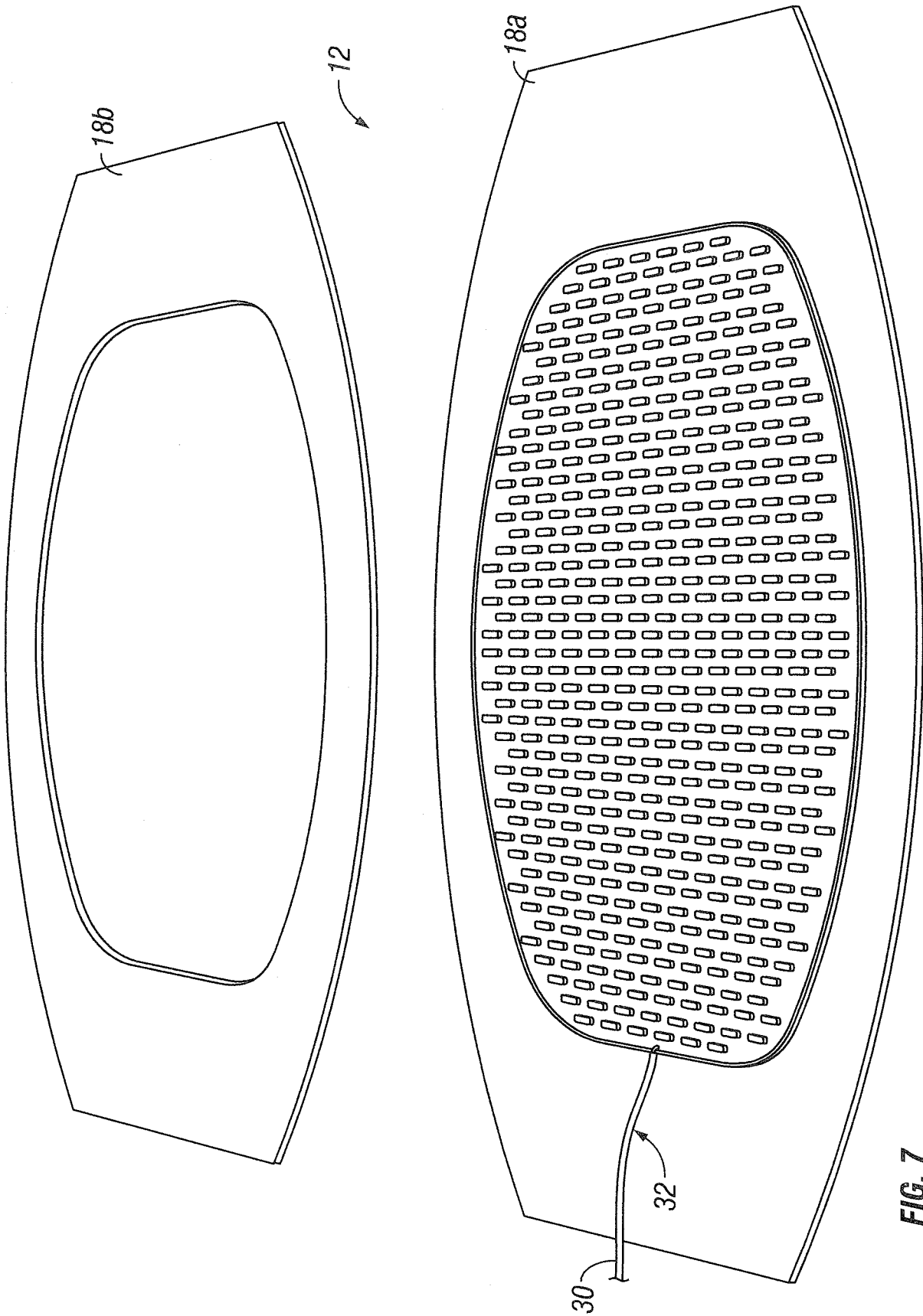

FIG. 7

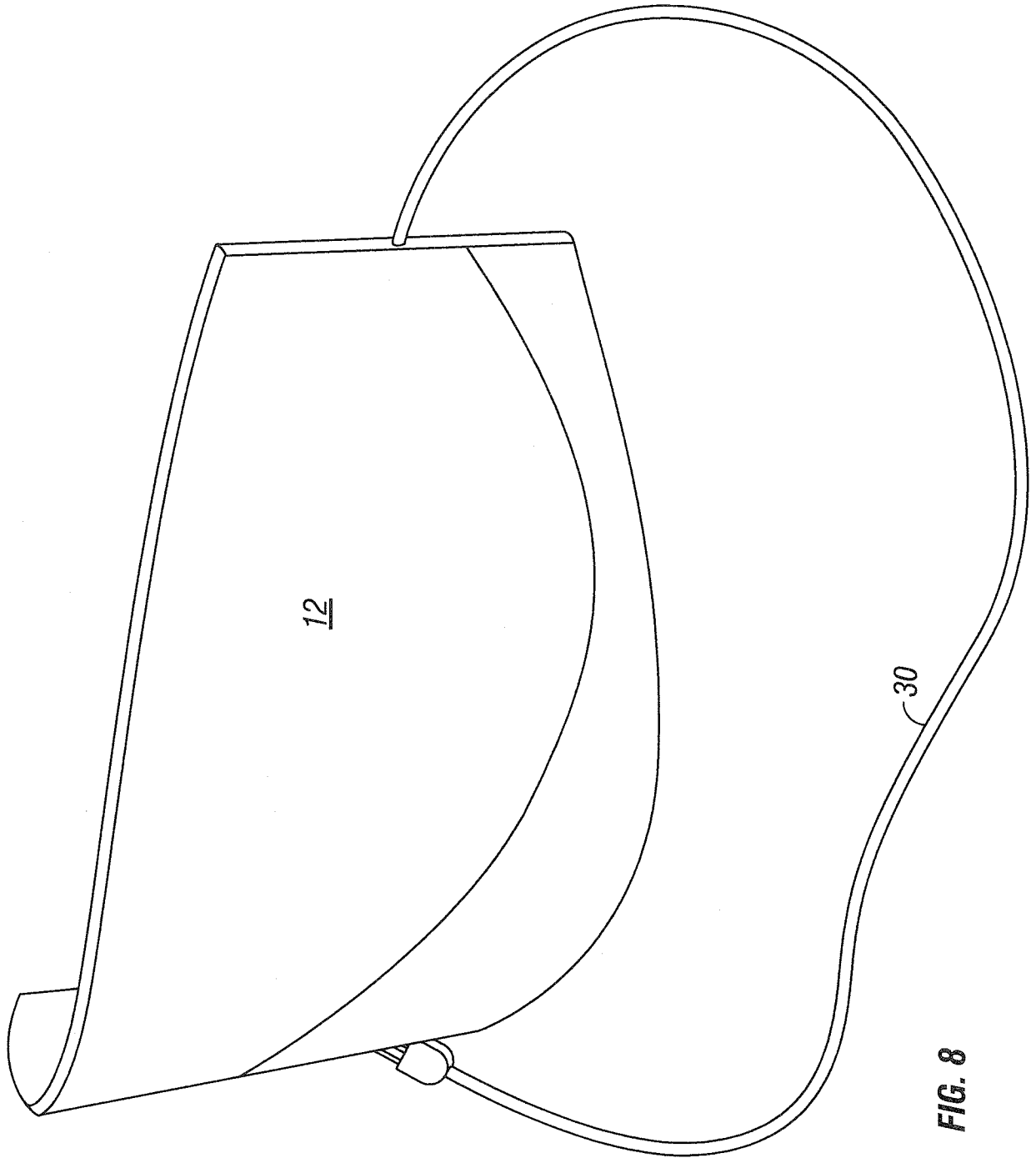

FIG. 8

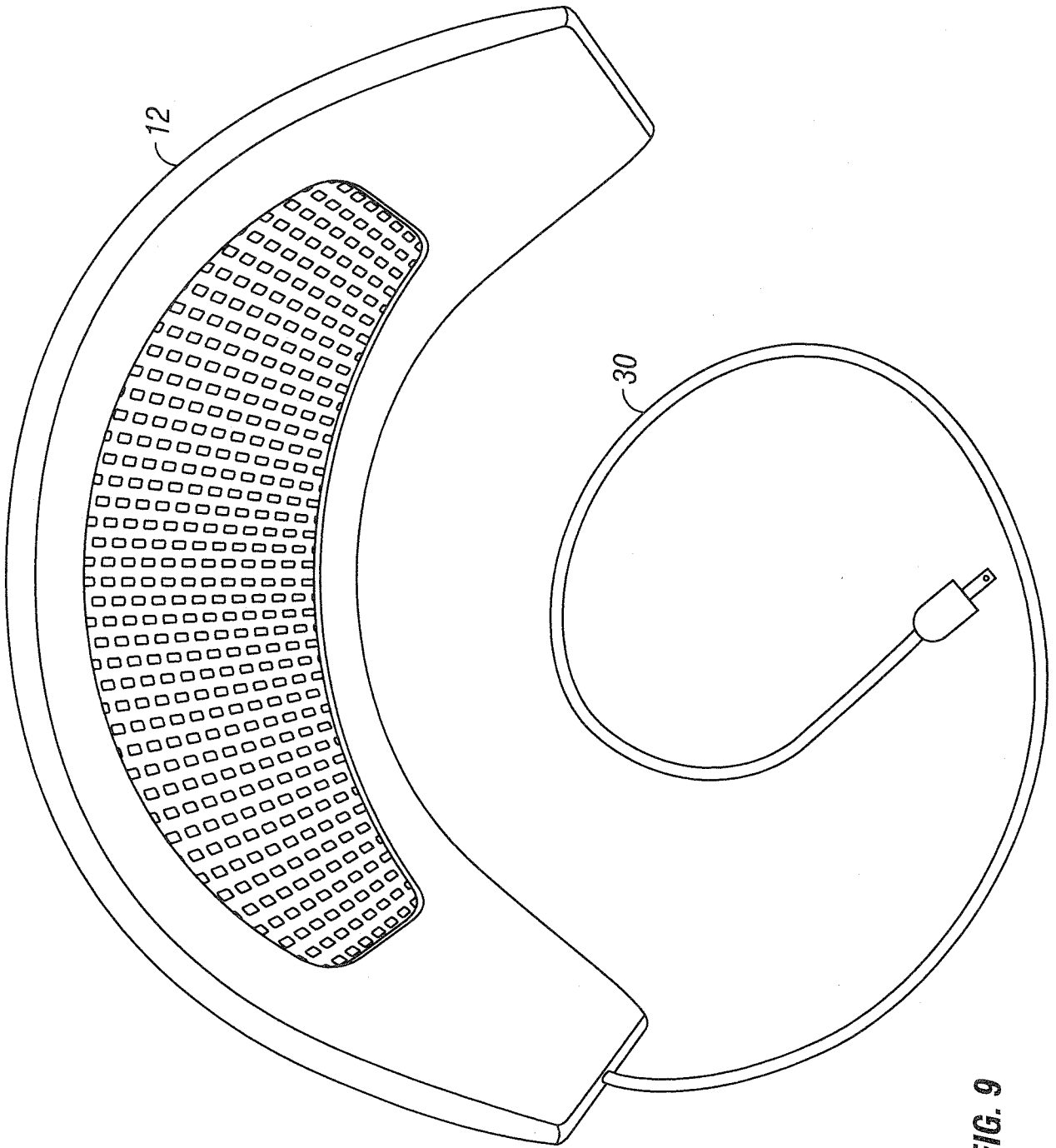

FIG. 9

9/17

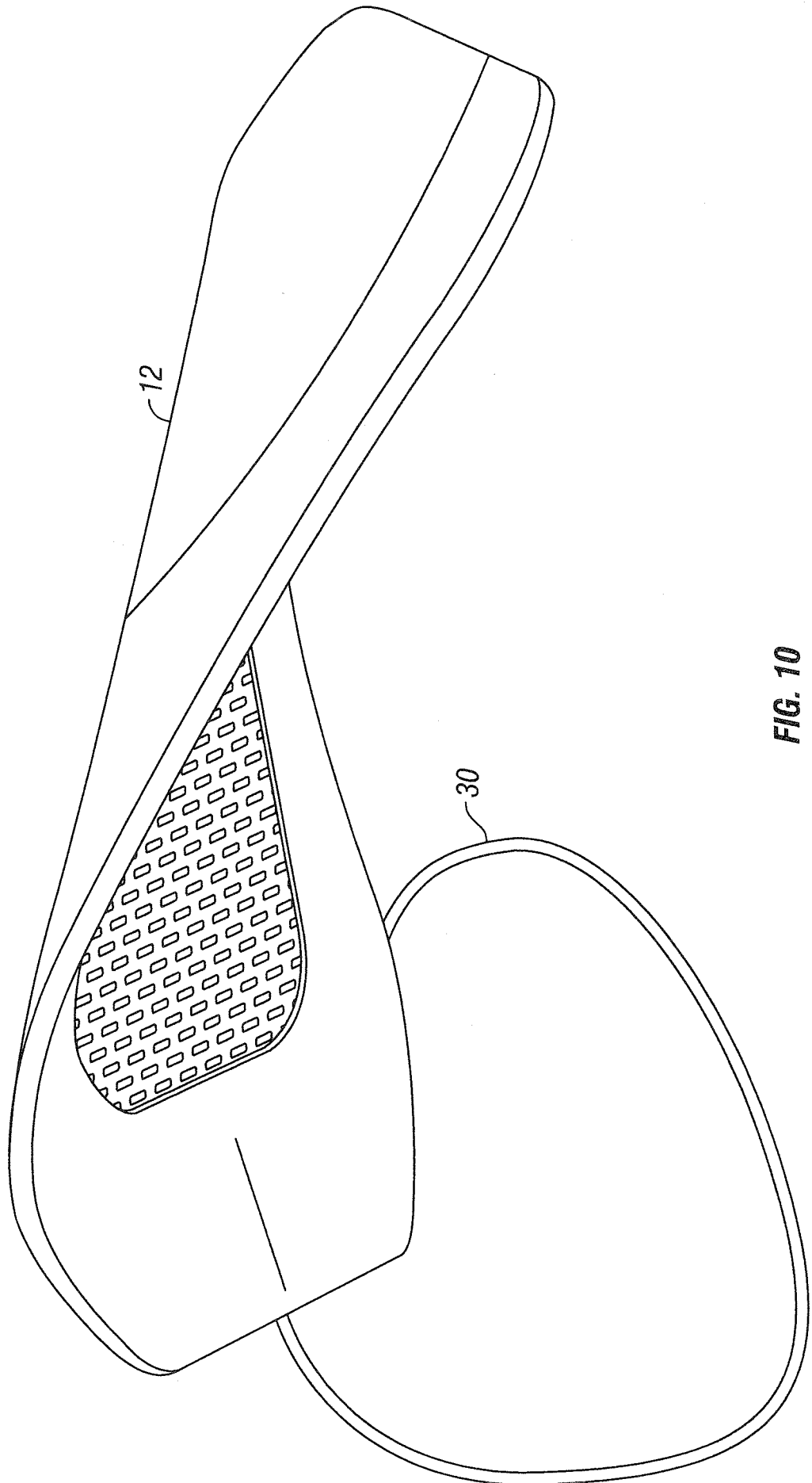

FIG. 10

10/17

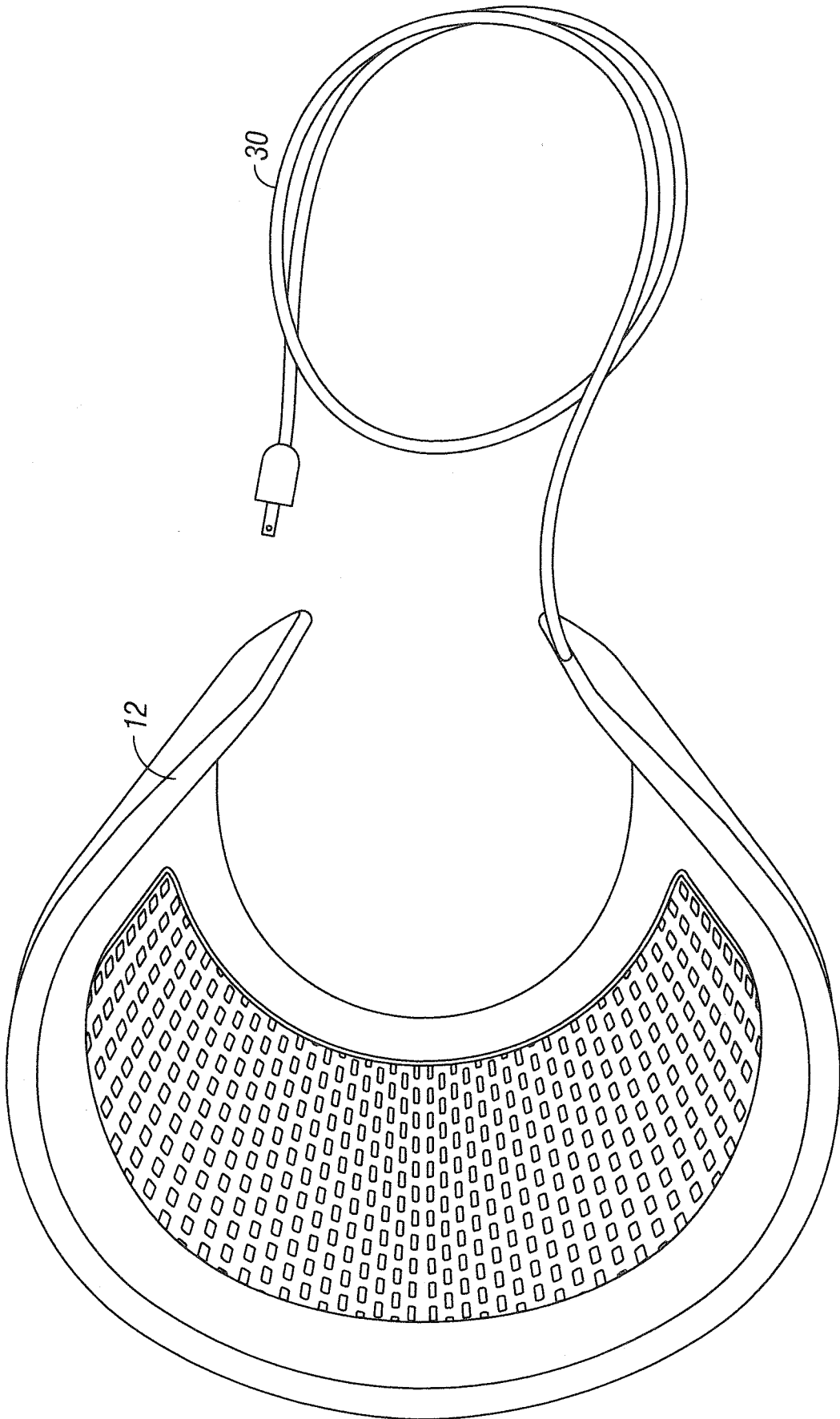

FIG. 11

11/17



FIG. 12

12/17

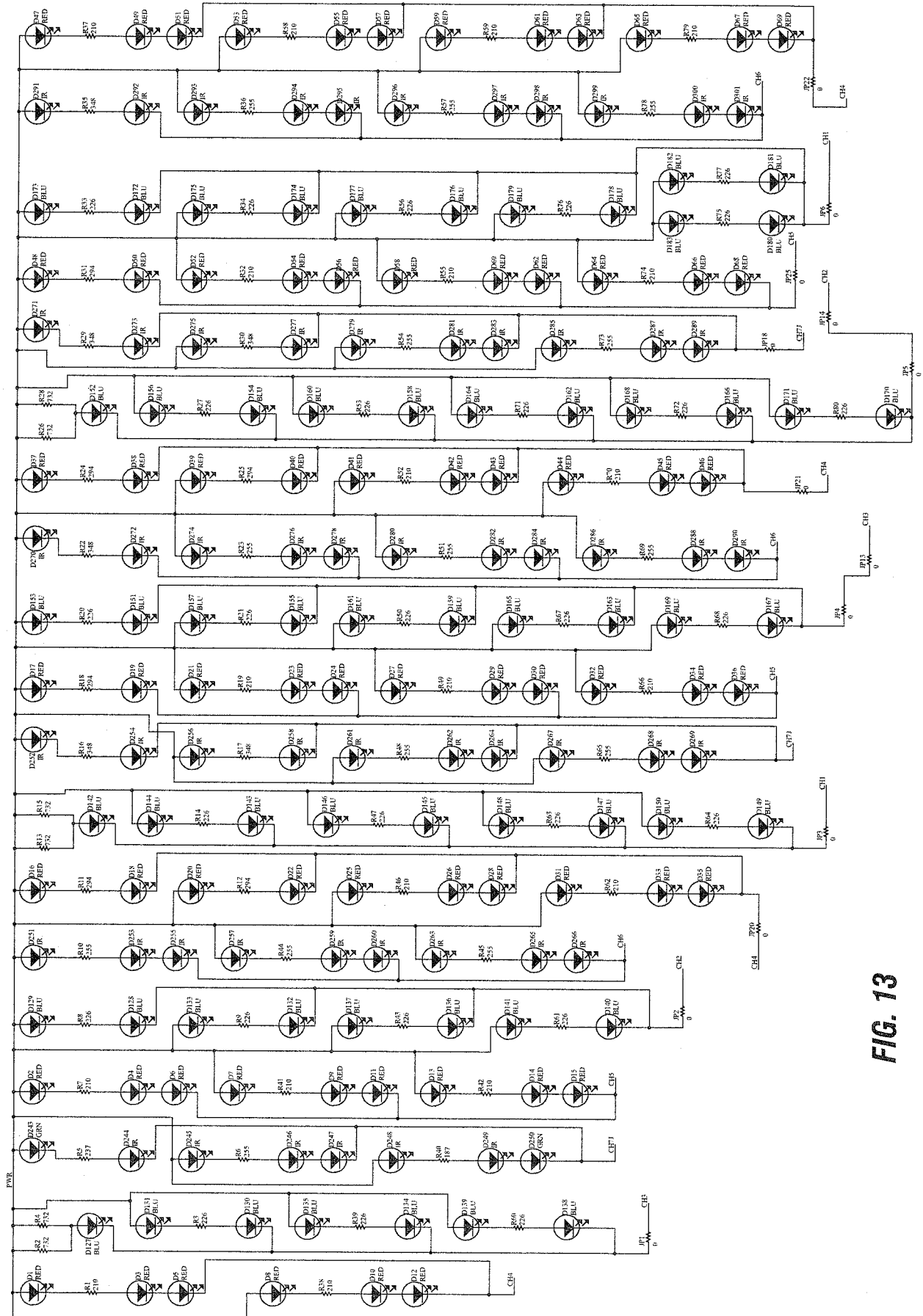

FIG. 13

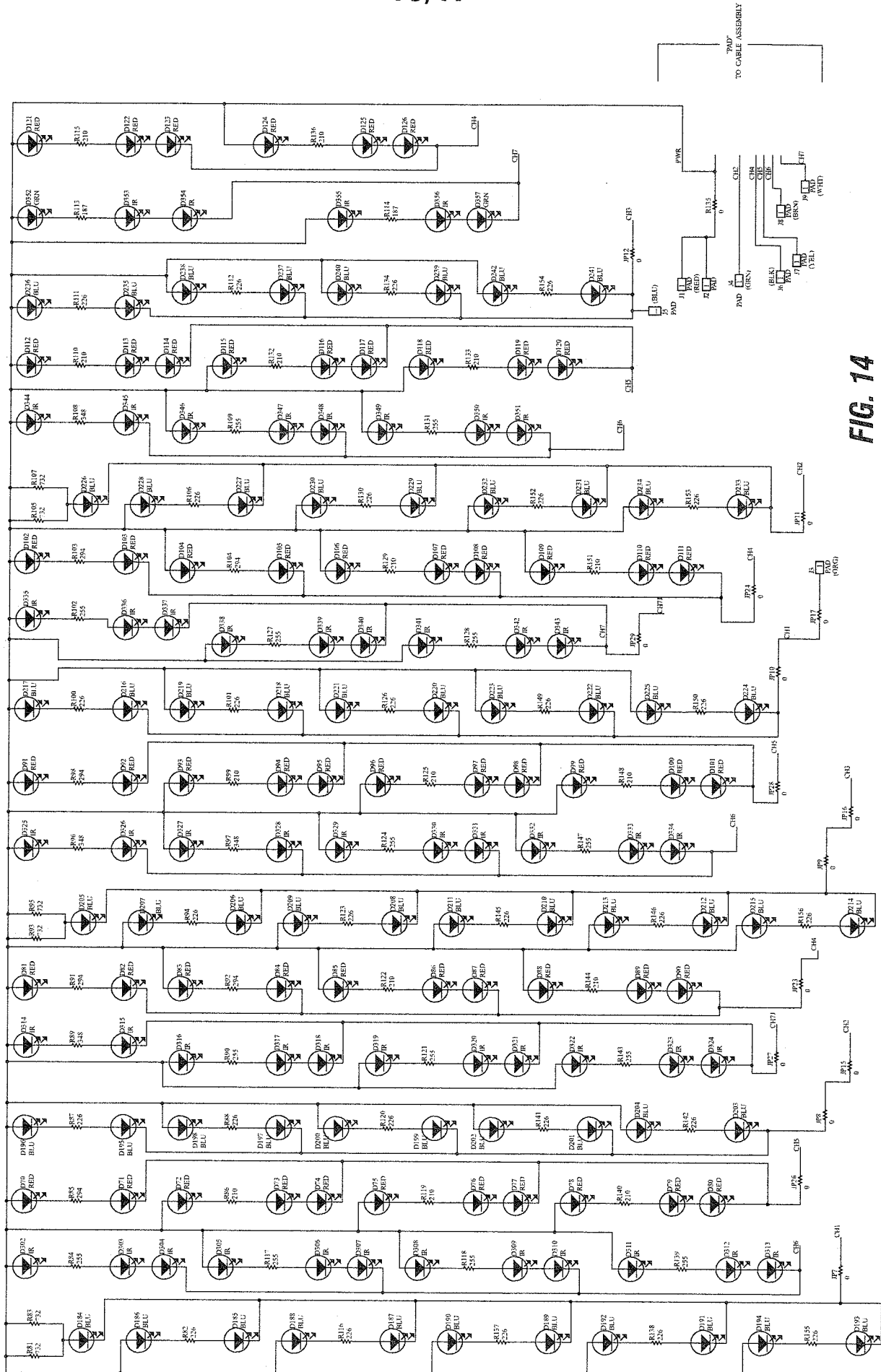

FIG. 14



FIG. 16

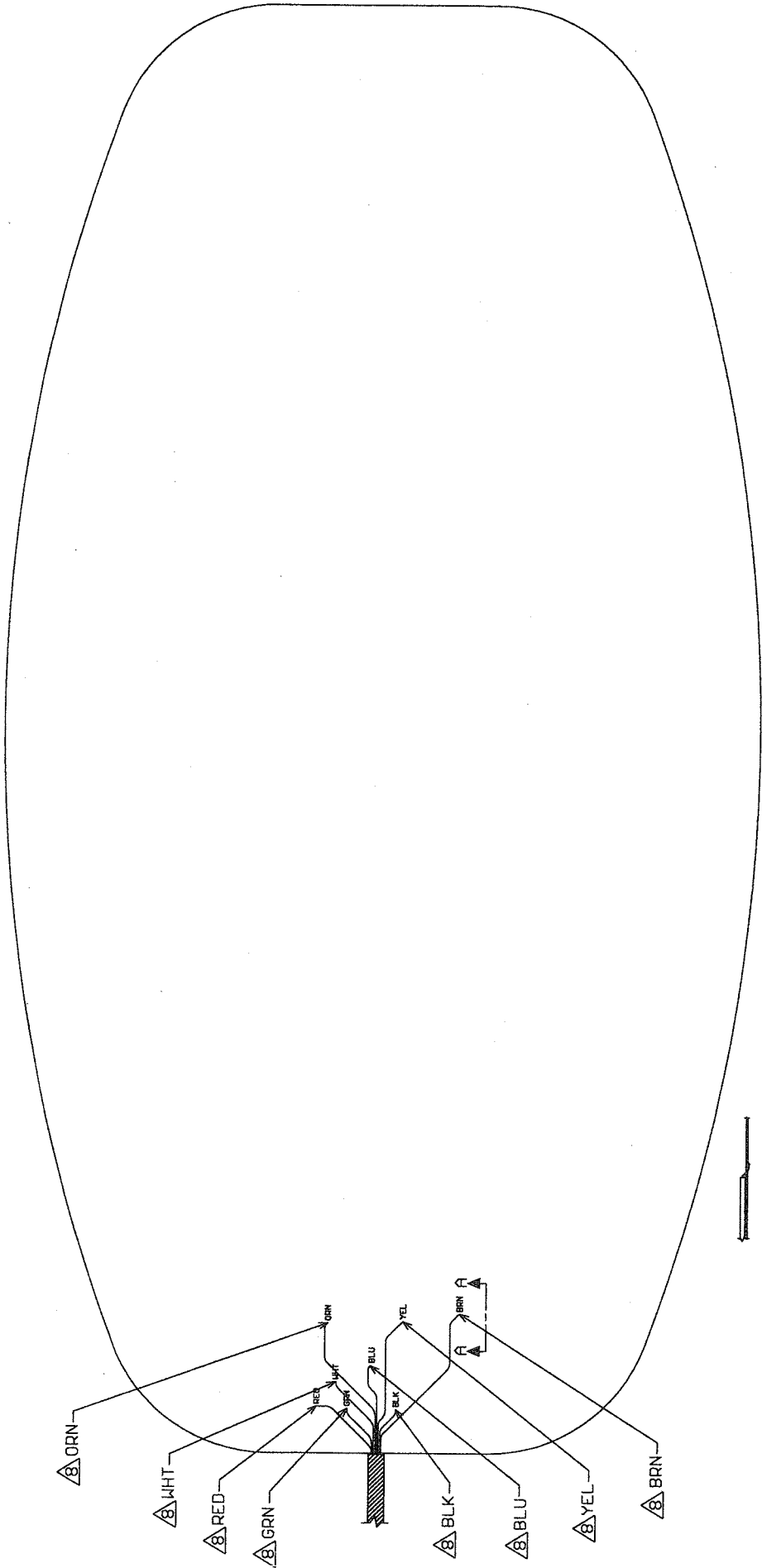

FIG. 17

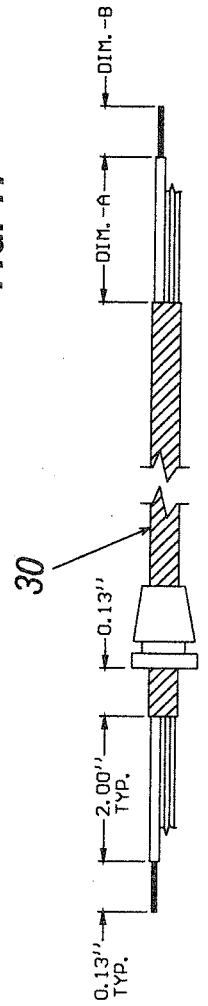

FIG. 18

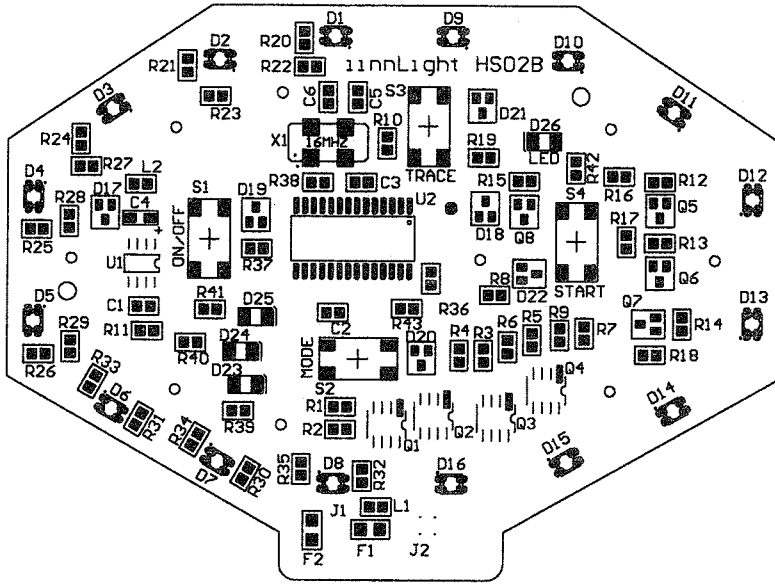

FIG. 19

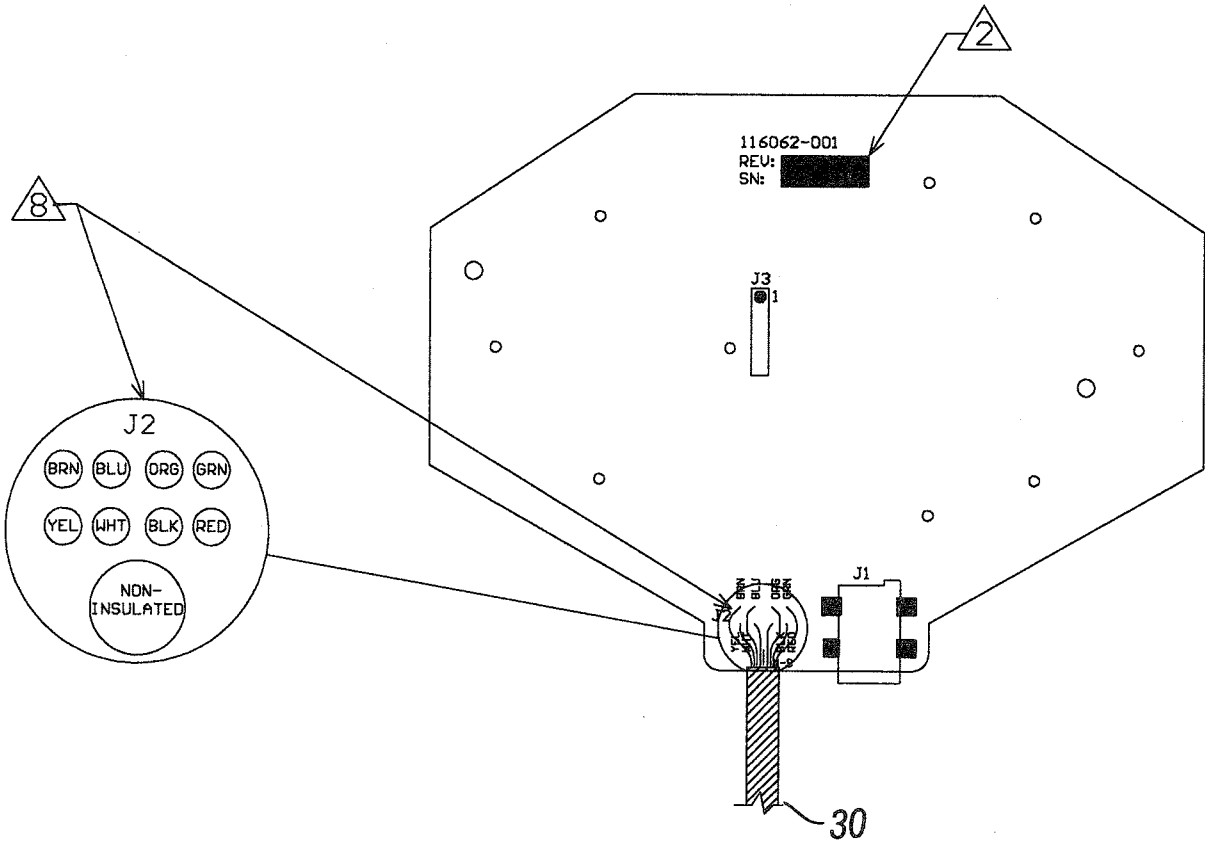

FIG. 20