



(43) International Publication Date
5 January 2017 (05.01.2017)

- (51) International Patent Classification:
B01F 5/02 (2006.01) *A61C 17/022* (2006.01)
B01F 3/04 (2006.01)
- (21) International Application Number:
PCT/CN2015/082901
- (22) International Filing Date:
30 June 2015 (30.06.2015)
- (25) Filing Language: English
- (26) Publication Language: English
- (72) Inventors; and
(71) Applicants : LIN, Kechuang [CN/CN]; No.1721-1725, Lvling Road, Siming District, Xiamen, Fujian 361009 (CN). HUANG, Yi-Jui [CN/CN]; No.1721-1725, Lvling Road, Siming District, Xiamen, Fujian 361009 (CN).
- (81) Designated States (unless otherwise indicated, for every kind of national protection available): AE, AG, AL, AM, AO, AT, AU, AZ, BA, BB, BG, BH, BN, BR, BW, BY, BZ, CA, CH, CL, CN, CO, CR, CU, CZ, DE, DK, DM,

DO, DZ, EC, EE, EG, ES, FI, GB, GD, GE, GH, GM, GT, HN, HR, HU, ID, IL, IN, IR, IS, JP, KE, KG, KN, KP, KR, KZ, LA, LC, LK, LR, LS, LU, LY, MA, MD, ME, MG, MK, MN, MW, MX, MY, MZ, NA, NG, NI, NO, NZ, OM, PA, PE, PG, PH, PL, PT, QA, RO, RS, RU, RW, SA, SC, SD, SE, SG, SK, SL, SM, ST, SV, SY, TH, TJ, TM, TN, TR, TT, TZ, UA, UG, US, UZ, VC, VN, ZA, ZM, ZW.

(84) Designated States (unless otherwise indicated, for every kind of regional protection available): ARIPO (BW, GH, GM, KE, LR, LS, MW, MZ, NA, RW, SD, SL, ST, SZ, TZ, UG, ZM, ZW), Eurasian (AM, AZ, BY, KG, KZ, RU, TJ, TM), European (AL, AT, BE, BG, CH, CY, CZ, DE, DK, EE, ES, FI, FR, GB, GR, HR, HU, IE, IS, IT, LT, LU, LV, MC, MK, MT, NL, NO, PL, PT, RO, RS, SE, SI, SK, SM, TR), OAPI (BF, BJ, CF, CG, CI, CM, GA, GN, GQ, GW, KM, ML, MR, NE, SN, TD, TG).

Published:
— with international search report (Art. 21(3))

(54) Title: BUBBLE-GENERATION APPARATUS AND SYSTEM

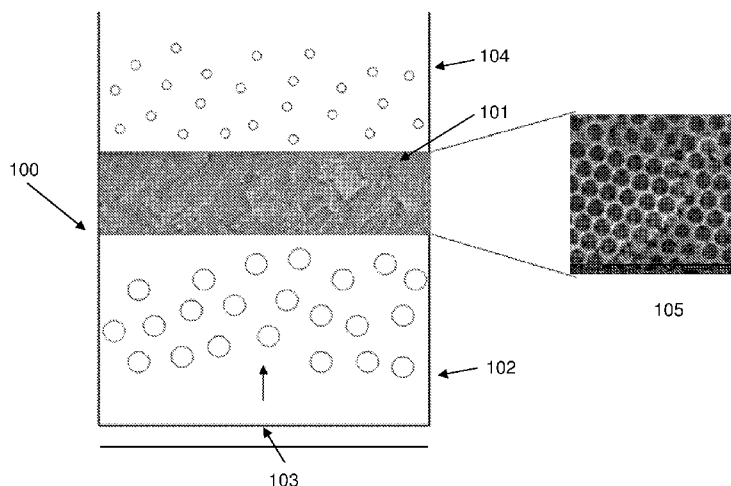

FIG. 1

(57) Abstract: A super-fine bubble generation apparatus is provided herein, which includes a fine-array porous membrane and a means for generating substantially uniform, super-fine gas bubbles in a liquid. The fine-array porous membrane includes a plurality of pores having a substantially uniform size of <math><100\ \mu\text{m}</math>, with a variation of <math><20\ \%\</math>. The super-fine gas bubbles generated by this apparatus may have a size of 50 nm -50000 nm, with a substantially uniform distribution with variations <math><20\ \%\</math>. Applications of such super-fine bubble generation apparatus are also provided herein, including a skin cleansing device and a teeth cleaning device which comprise such super-fine bubble generation apparatus.



BUBBLE-GENERATION APPARATUS AND SYSTEM

BACKGROUND

[001] Air bubbles or gas bubbles can be generated in a number of ways in a liquid such as water. For example, boiling water or cavitation can generate large air bubbles. The technology of controlling the generation and/or collapsing of gas bubbles in a liquid has been widely applied in various fields such as sewage treatment (by providing substantial mass transfer of oxygen to wastewater), industrial cleaning (by generating controlled acoustic cavitation in the cleaning fluid for cleaning contaminants), industrial mixing (by breaking down and homogenizing suspended particles in a liquid solution), and biomedical engineering (for example, to destruct kidney stones in shock wave lithotripsy).

SUMMARY

[002] The present disclosure relates to a super-fine bubble generation apparatus or system that comprises a fine-array porous membrane, and to its practical applications.

[003] It may be possible to generate gas bubbles using foam materials. Existing foam materials may have pore sizes of 0.5 ~ 8 mm, and may have a specific surface area of 14 ~ 3100/mm. However, the pore sizes of these foam materials have a large variation, for example >100%.

[004] Some embodiments disclosed herein comprise high surface-area-to-volume ratio fine-array porous material. The fine-array porous material can be a fine-array membrane, having a thickness of 10 μm - 50000 μm , and preferably of 100 μm - 1000 μm . The fine-array porous material can have a surface area larger than 100 cm^2 , such as 20 $\text{cm} \times 20 \text{ cm}$.

The sizes of the pores can be, for example, less than about 100 μm , and preferably less than about 25 μm . Compared with existing foam materials, the size of the pores in the fine-array porous material disclosed herein is substantially uniform with a variation of less than about 20% and preferably of less than about 10%. In some embodiments, the fine-array porous material can include a plurality of grain boundary regions filled with a solid material or film to increase the mechanical strength of the fine-array porous material, wherein the specific surface area is higher than 410/mm, the size variation is less than about 10%, and the grain boundary regions have a size of about 5 μm - 15 μm . In some embodiments, the fine-array porous material may have little or no grain boundaries.

[005] An apparatus for generating fine gas bubbles, and more specifically, for generating substantially uniform, super-fine gas bubbles in a liquid is disclosed herein. The apparatus may include a fine-array porous membrane with a specific surface area higher than about 410/mm, the specific surface area depending on different pore sizes. The fine-array porous membrane comprises a plurality of pores, wherein the plurality of pores have a size of less than about 100 μm , and preferably less than about 25 μm . The size of the plurality of pores is substantially uniform with a variation of less than about 20% and preferably of less than about 10%. In some embodiments, the fine-array porous membrane in the apparatus may be made of polymer, ceramic, metal, or a composite material. For examples, the fine-array porous membrane in the apparatus may be made of SiO_2 , TiO_2 , Al_2O_3 , or ZnO .

[006] The super-fine bubble generation apparatus disclosed herein also comprises a means for generating super-fine gas bubbles in the liquid. The means for generating super-fine gas bubbles is configured to push gas bubbles contained in the liquid on a first

side of the fine-array porous membrane through to a second side of the fine-array porous membrane to generate super-fine gas bubbles in the liquid on the second side of the fine-array porous membrane.

[007] In some embodiments, the means for generating super-fine gas bubbles comprises a high-pressure liquid injection device, configured to apply a pressure on the liquid from the first side of the fine-array porous membrane through to the second side of the fine-array porous membrane to generate super-fine gas bubbles. The liquid on the first side of the fine-array porous membrane can contain a large amount of large gas bubbles with sizes of $>50 \mu\text{m}$. The volumetric ratio between liquid and gas bubbles can be, for example, 1:1 - 10000:1, and preferentially 20:1 - 500:1.

[008] In some embodiments, the means for generating super-fine gas bubbles comprises an ultrasound vibration device, wherein the ultrasound vibration device is disposed on the first side of the fine-array porous membrane and at a position that directionally points at the fine-array porous membrane. The ultrasound vibration device is configured to work at a frequency of $>20 \text{ KHz}$, preferably at a range of $80 \text{ KHz} - 200 \text{ KHz}$, and at a power of $<0.5 \text{ W/cm}^2$, preferably at a range of $0.01 \text{ W/cm}^2 - 0.1 \text{ W/cm}^2$.

[009] The large air bubbles at the first side of the fine-array porous membrane traverse the membrane as a result of the water pressure and/or the vibration from the ultrasound, and generate substantially uniform super-fine bubbles at the second side of the fine-array porous membrane. The size of the super-fine bubbles can be controlled by selecting the fine-array porous membrane with desired pore sizes.

[0010] In some embodiments, the liquid can be water. In some embodiments, the liquid can be an organic solvent, such as EtOH (alcohol), ACE(acetone), IPA(isopropyl alcohol),

and toluene. In some embodiments, the liquid can be an oil. In some embodiments, the gas bubbles can be air bubbles, and in other embodiments, the gas bubbles can be made of a gas such as CO₂, N₂, or an inactive gas.

[0011] In some embodiments, the fine-array porous membrane can be surface-treated to improve the efficiency to generate super-fine gas bubbles, depending on the composition of the fine-array porous membrane and the type of the liquid that is used. In some embodiments where super-fine gas bubbles need to be generated in a liquid with a high viscosity, for example, oil, the fine-array porous membrane can be surface-treated to become hydrophobic or oleophobic, in order to facilitate the flow of gas bubbles through the fine-array porous membrane by reducing the electrostatic adherence of the liquid on the surface of the fine-array porous membrane. In embodiments where the fine-array porous membrane is made of a metal, such as Al, Ti, Ni and Cu, a ceramic such as TiO₂, Al₂O₃ and ZnO, or a polymer such as polystyrene and silicone, a hydrophobic group can be added to the surface of the fine-array porous membrane through dehydrolysis between the hydroxyl group of the fine-array porous membrane and the hydrophilic group of a surfactant that also contains the hydrophobic group. In one example, a fine-array porous membrane made of Cu (containing CuO or Cu₂O on the surface) can be surface-treated with perfluorooctyltriethoxysilane to make the surface of the porous membrane hydrophobic. In some embodiments where a liquid with a low viscosity, such as water, is used, the fine-array porous membrane can be surface-treated to become hydrophilic, and the electric potential of the surface of the fine-array porous membrane is configured to equal to the electric potential of the gas bubbles, in order to facilitate the flow-through of

the gas bubbles mediated by electro-osmosis between the liquid and the fine-array porous membrane.

BRIEF DESCRIPTION OF THE DRAWINGS

[0012] FIG. 1 illustrates a fine-bubble generation apparatus.

[0013] FIG. 2 illustrates a fine-bubble generation apparatus comprising a high-pressure liquid injection device according to some embodiments.

[0014] FIG. 3 illustrates a fine-bubble generation apparatus comprising an ultrasound vibration device.

[0015] FIG. 4 illustrates a skin cleansing device having a fine-bubble generation apparatus.

[0016] FIG. 5 is a diagram illustrating a teeth cleaning device having a fine-bubble generation apparatus.

DETAILED DESCRIPTION

[0017] Embodiments disclosed herein provide an apparatus or system configured to generate super-fine air bubbles, such as bubbles $< 50 \mu\text{m}$ in size, for example $< 10 \mu\text{m}$ in diameter. The size of super-fine air bubbles depends on the pore size, and is estimated to be around pore size $\pm 20\%$. For example, an apparatus with a pore size of $50 \mu\text{m}$ can generate super-fine air bubbles with a size of about $40 - 60 \mu\text{m}$. These super-fine air bubbles can float slowly in the water. Some of the super-fine air bubbles can dissolve in the water, thereby increasing the levels of dissolved oxygen in the water. The bubbles

can also burst quickly, and when a large number of bubbles burst, a lot of heat can be generated in the process. In some cases, rupture of the air bubbles can also generate ultrasonic wave and/or negative ions, etc. in the water.

[0018] The dissolved oxygen carried by the super-fine air bubbles, and the heat, ultrasonic waves, and/or negative ions generated by rupture of the super-fine bubbles can have a variety of health benefits, and thus the super-fine bubbles can be used in cosmetics or health care. As an example, super-fine bubbles with a diameter of $<10\ \mu\text{m}$ can easily penetrate into pores on the skin, and thus in some embodiments, the super-fine air bubble generated by the disclosed apparatus can be used in a skin cleanser product to deep clean dirt, oil and makeup from skin pores, preventing the formation of and alleviating the symptoms of acne. In another example, rupture of super-fine bubbles in water can generate a large amount of heat, ultrasonic waves and/or oxygen anions which may have therapeutic effect, and thus in some other embodiments, super-fine bubbles generated by the disclosed apparatus can be used in therapeutic products for skin care, skin cleansing, whitening, hydrating the skin, improving elasticity, alleviating athlete's foot, acne treatment and eczema treatment.

[0019] FIG. 1 illustrates a fine-bubble generation apparatus. The apparatus 100 comprises a fine-array porous membrane 101, a first chamber 102 filled with a large gas bubble-containing liquid on a first side of the fine-array porous membrane 101, a means for generating super-fine gas bubbles 103 disposed on one end of the first chamber 102, and a second chamber 104 containing the liquid with super-fine bubbles. A magnified view of the fine-array porous membrane is shown in 105. The fine-array porous membrane may have a thickness of $10\ \mu\text{m}$ - $50000\ \mu\text{m}$, and preferably of $100\ \mu\text{m}$ - 1000

μm . The fine-array porous membrane may have a surface area of larger than 100 cm^2 , such as $20\text{ cm} \times 20\text{ cm}$. The sizes of the pores can be, for example, less than about $100\ \mu\text{m}$, and preferably less than about $25\ \mu\text{m}$. The size of the pores is substantially uniform with a variation of less than about 20% and preferably of less than about 10%. Different sizes of the pores in the fine-array porous membrane can be selected to control the sizes of the super-fine air bubbles that are generated, such as $50\text{ nm} - 50000\text{ nm}$.

[0020] FIG. 2 illustrates a fine-bubble generation apparatus comprising a high-pressure liquid injection device according to some embodiments. In the apparatus 200, a high-pressure liquid injection device 203 is the means for generating super-fine gas bubbles, which substantially pushes the large gas bubble-containing liquid in the first chamber 202 through the fine-array porous membrane 201 to generate super-fine gas bubbles in the second chamber 204. In some embodiments, the liquid can be water and the gas bubbles can be air bubbles. In these embodiments, the high-pressure water injection device can work at a pressure of $< 100\text{ Pa}$, and preferably of $0.1\text{ Pa} - 10\text{ Pa}$. Water under the high pressure can contain a large number of large air bubbles, for example with sizes of $>50\ \mu\text{m}$. The volumetric ratio between water and air bubbles can be $1:1 - 10000:1$, and preferably around $20:1-500:1$. In some embodiments, other liquid, such as an organic solvent and oil, can be used. Examples of an organic solvent include EtOH (Alcohol), ACE (Acetone), IPA (isopropyl alcohol), and toluene. The pressure needs be selected based on the type of the liquid used. Overly high pressure may cause the fine-array porous membrane to break.

[0021] In some embodiments, an ultrasound vibration device can be included in a super-fine bubble generation apparatus. As illustrated in FIG. 3, an ultrasound vibration device

303 is disposed on one end of a first chamber 302 filled with a liquid containing large gas bubbles, at a position that directionally points at the fine-array porous membrane 301, substantially allowing the ultrasonic wave released from the ultrasound vibration device 303 to push the gas bubbles in the first chamber 302 through the fine-array porous membrane 301 to generate super-fine gas bubbles in the liquid contained in a second chamber 304. [in FIG.3, it's preferable that the second chamber 304 is drawn as in FIGs. 1 and 2] The ultrasound vibration device can be configured to work at a frequency of >20 KHz, preferably at a range of 80 KHz - 200 KHz, and at a power of <0.5 W/cm², preferably at a range of 0.1W/cm² - 0.01W/cm².

[0022] In both the embodiments that comprise a high-pressure liquid injection device, and the embodiments that comprises an ultrasound vibration device, the large gas bubbles at the first side of the fine-array porous membrane traverse the fine-array porous membrane under the water pressure and/or as a result of the vibration from the ultrasound, and generate substantially uniform super-fine air bubbles at the second side of the fine-array porous membrane. For example, the super-fine bubbles generated at the second side of the fine-array porous membrane can have a diameter distribution within about $\pm 20\%$. The size of the bubbles can be controlled by selecting the film with desired pore sizes.

[0023] In some embodiments, the fine-array porous membrane can be surface treated to become hydrophilic or hydrophobic, depending on the type and nature of the liquid that is used. In some embodiments where a liquid with a high viscosity is used, the fine-array porous membrane can be surface-treated to become hydrophobic, in order to facilitate the flow of gas bubbles through the fine-array porous membrane by reducing the electrostatic

adherence of the liquid on the surface of the fine-array porous membrane. In some embodiments where a liquid with a low viscosity, such as water, is used, the fine-array porous membrane can be surface-treated to become hydrophilic, and the electric potential of the surface of the fine-array porous membrane is configured to equal to the electric potential of the bubbles, in order to facilitate the flow-through of the gas bubbles via electro-osmosis between the liquid and the fine-array porous film.

[0024] FIG. 4 illustrates a skin cleansing device 400 having a fine-bubble generation unit 401. The fine-bubble generation unit 401 is disposed inside a head unit of the skin cleansing device 400, and is configured to push a skin-cleansing liquid containing large air-bubbles outward through a fine-array porous membrane 402 to generate skin-cleansing liquid containing super-fine air bubbles in a controllable manner. A high-pressure liquid injection device or an ultrasound vibration device may be used for this purpose. The super-fine air bubbles generated by this skin care apparatus can carry an increased level of oxygen and negative ions, and can also easily penetrate into pores on the skin for deep cleaning and for cosmetic care. This skin cleansing apparatus may further comprise a plurality of brushes 403 perpendicularly disposed on the outer surface of the fine-array porous membrane 402. In some embodiments, the plurality of brushes comprise fine-array porous filaments and may have a diameter of less than about 1 μm , which can further enhance the beneficial effect brought about by the super-fine bubbles generated by the skin cleansing apparatus.

[0025] FIG. 5 is a diagram illustrating a teeth cleansing device 500 having a super-fine air bubble generation unit 502 and a water jet head unit 504. The water jet head unit 504 is configured to connect with the super-fine air bubble generation unit 502, such that the

teeth cleansing liquid containing super-fine air bubbles generated by the super-fine air bubble generation unit 502 is transferred to and accelerated by the water jet head unit for dental floss. In some embodiments, the water jet head unit 504 further contains a fine-array porous material similar to the brushes of FIG. 4, which can brush the teeth while flossing with the water jet.

[0026] Although specific embodiments have been described above in detail, the description is merely for purposes of illustration. It should be appreciated, therefore, that many aspects described above are not intended as required or essential elements unless explicitly stated otherwise. Various modifications of, and equivalent acts corresponding to, the disclosed aspects of the exemplary embodiments, in addition to those described above, can be made by a person of ordinary skill in the art, having the benefit of the present disclosure, without departing from the spirit and scope of the disclosure defined in the following claims, the scope of which is to be accorded the broadest interpretation so as to encompass such modifications and equivalent structures.

Claims

1. A apparatus for generating substantially uniform, super-fine gas bubbles in a liquid, comprising:
 - a fine-array porous membrane, and
 - a means for generating super-fine gas bubbles in a liquid, wherein:
 - the fine-array porous membrane comprises a plurality of pores, wherein the plurality of pores have a size of less than about 100 μm , and the size of the plurality of pores is substantially uniform with a variation of less than about 20%;
 - the means for generating super-fine gas bubbles is configured to push gas bubbles contained in the liquid on a first side of the fine-array porous membrane through to a second side of the fine-array porous membrane to generate super-fine gas bubbles in the liquid on the second side of the fine-array porous membrane.
2. The apparatus of Claim 1, wherein the fine-array porous membrane has a thickness of about 10 μm -50000 μm .
3. The apparatus of Claim 2, wherein the fine-array porous membrane has a thickness about 100 μm -1000 μm .
4. The apparatus of Claim 1, wherein the plurality of pores have a size of less than about 25 μm .
5. The apparatus of Claim 1, wherein the size of the plurality of pores is substantially uniform with a variation of less than about 10%.
6. The apparatus of Claim 1, wherein the means for generating super-fine gas bubbles in a liquid comprises a high-pressure liquid injection device, wherein

the high-pressure liquid injection device is disposed on the first side of the fine-array porous membrane.

7. The apparatus of Claim 6, wherein the high-pressure liquid injection device is configured to work at a pressure of less than about 100 Pa.
8. The apparatus of Claim 7, wherein the high-pressure liquid injection device is configured to work at a pressure of about 0.1 Pa - 10 Pa.
9. The apparatus of Claim 8, wherein the liquid at the first side of the fine-array porous membrane contains gas bubbles having a size of more than about 50 μm and have a volumetric ratio of about 1:1 - 10000:1.
10. The apparatus of Claim 9, wherein the gas bubbles have a volumetric ratio of about 20:1-500:1.
11. The apparatus of Claim 1, wherein the means for generating super-fine gas bubbles in a liquid comprises an ultrasound vibration device, wherein
the ultrasound vibration device is disposed on the first side of the fine-array porous membrane and at a position that directionally points at the fine-array porous membrane.
12. The apparatus of Claim 11, wherein the ultrasound vibration device is configured to work at a frequency of higher than about 20 KHz and at a power of lower than about 0.5 W/cm^2 .
13. The apparatus of Claim 12, wherein the ultrasound vibration device is configured to work at a frequency of about 80 - 200 KHz, and at power of about 0.1 W/cm^2 - 0.01 W/cm^2 .
14. The apparatus of Claim 1, wherein the liquid is water, an organic solvent, or an oil.
15. The apparatus of Claim 1, wherein the fine-array porous membrane is made of one of polymer, ceramic, metal, or a composite material.

16. The apparatus of Claim 1, wherein the fine-array porous membrane is surface-treated to be hydrophilic or hydrophobic (oleophobic).
17. A skin cleansing device, comprising a super-fine bubble generation unit, wherein:
the super-fine bubble generation unit comprises a fine-array porous membrane, the fine-array porous membrane comprising a plurality of pores, wherein:
the plurality of pores have a size of less than about 100 μm ; and
the size of the plurality of pores is substantially uniform with a variation of less than about 20%.
18. The skin cleansing device according to Claim 17, further comprising a plurality of brushes, wherein the plurality of brushes comprises a plurality of fine-array porous filaments having a diameter of less than about 1 μm .
19. A teeth cleaning device, comprising:
a super-fine bubble generation unit; and
a water jet head unit, wherein:
the super-fine bubble generation unit comprises a fine-array porous membrane, the fine-array porous membrane comprising a plurality of pores, wherein:
the plurality of pores have a size of less than about 100 μm ; and
the size of the plurality of pores is substantially uniform with a variation of less than about 20%; and
the water jet head unit is connected to the super-fine bubble generation unit such that a liquid containing super-fine air bubbles generated by the super-fine air bubble generation unit is transferred to and accelerated by the water jet head unit.

20. The teeth cleaning device according to Claim 19, wherein the water jet head unit comprises a plurality of fine-array porous filaments having a diameter of less than about 1 μm .
21. The apparatus of Claim 1, wherein the fine-array porous membrane is made of SiO_2 , TiO_2 , Al_2O_3 , ZnO , and wherein the liquid is water.
22. The apparatus of Claim 16, wherein the fine-array porous membrane is made of Cu, and the fine-array porous membrane is surface-treated with perfluorooctyltriethoxysilane.

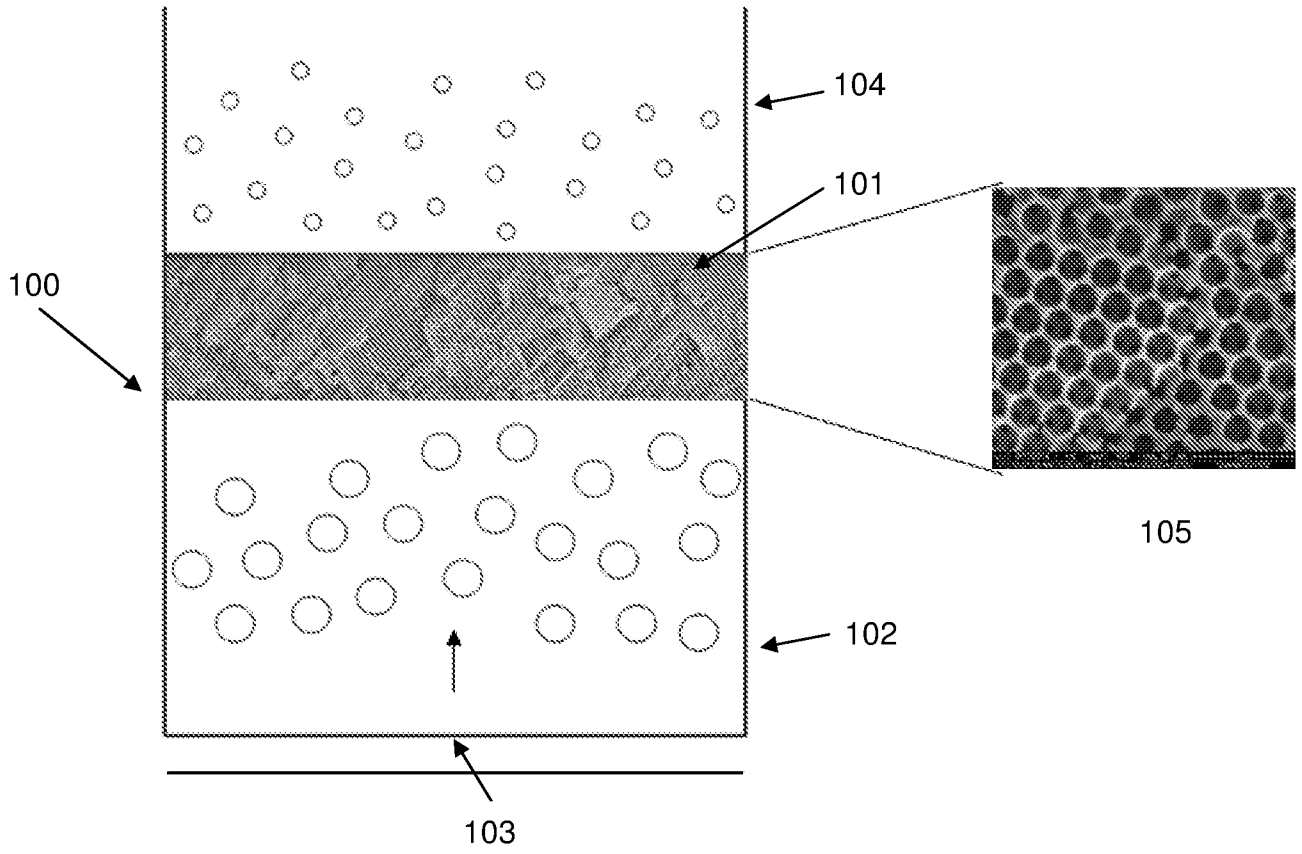

FIG. 1

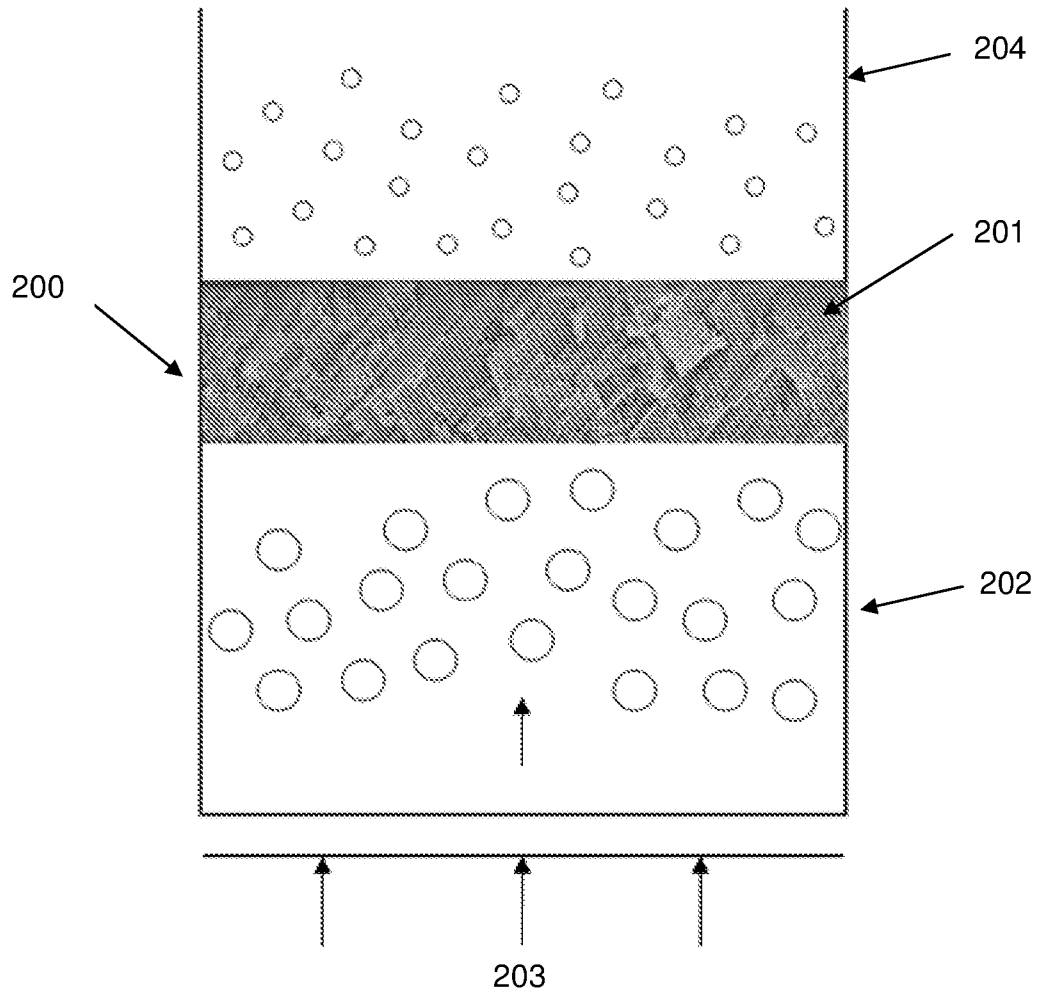

FIG. 2

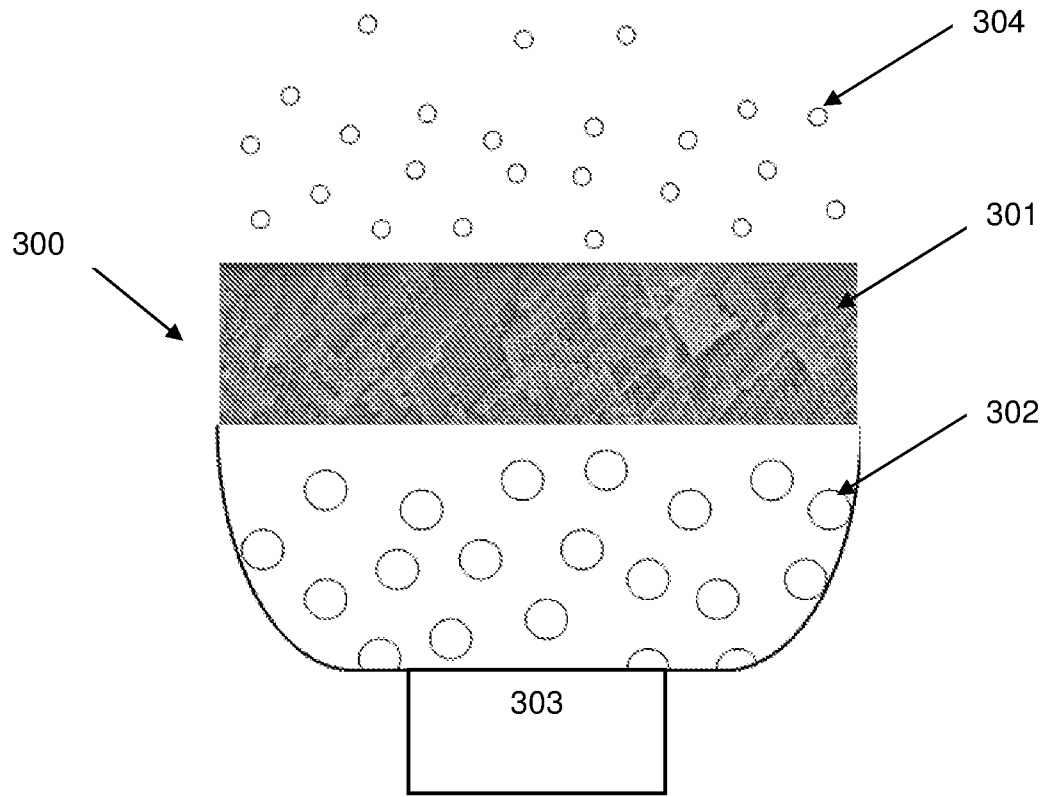

FIG. 3

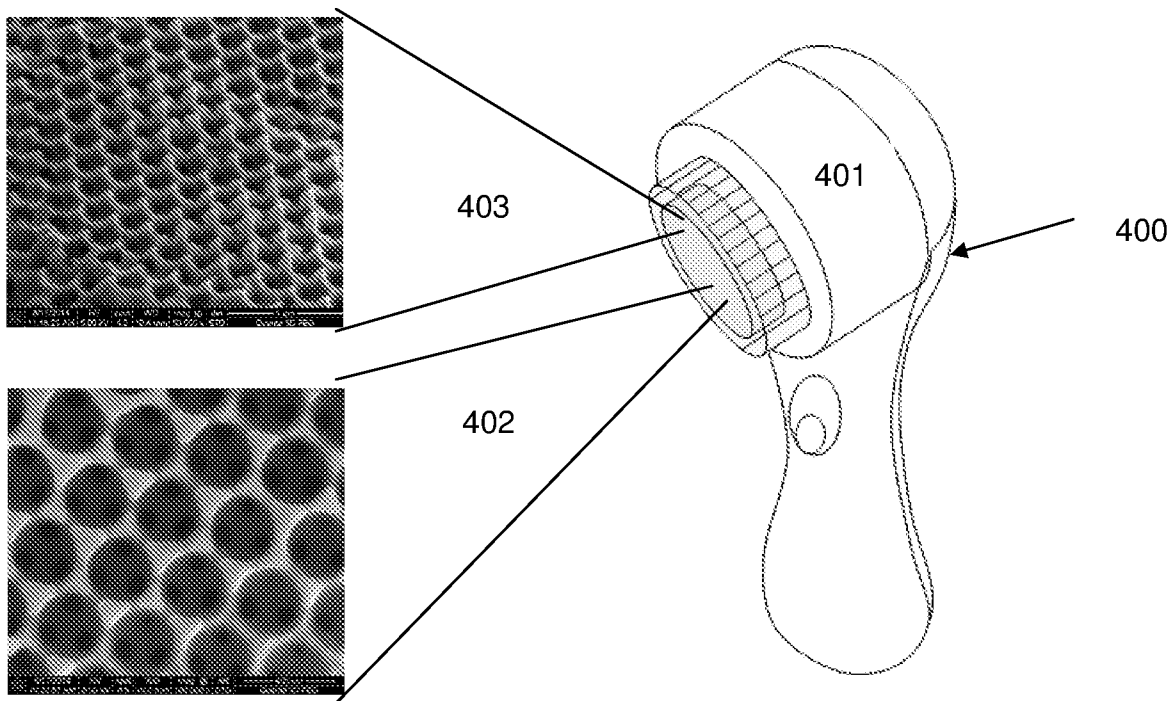

FIG. 4

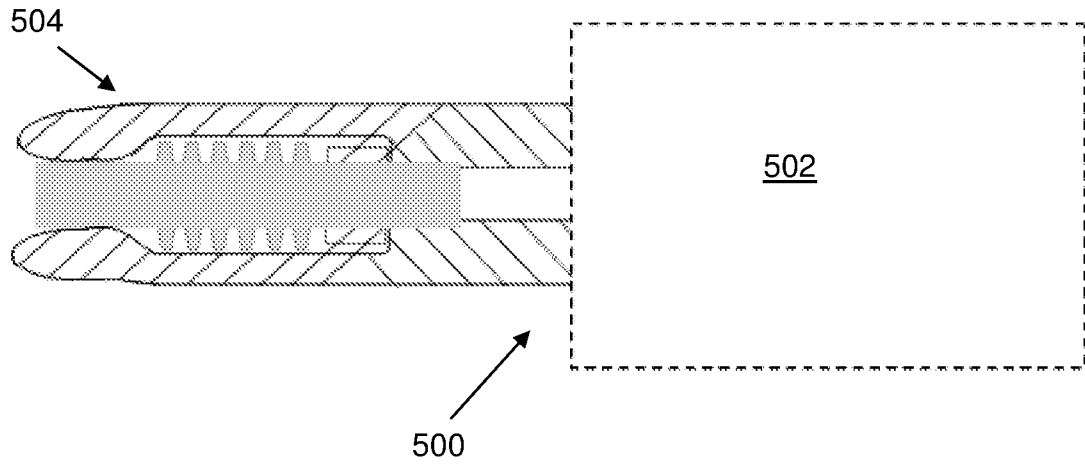

FIG. 5

INTERNATIONAL SEARCH REPORT

International application No.

PCT/CN2015/082901

A. CLASSIFICATION OF SUBJECT MATTER

B01F 5/02(2006.01)i; B01F 3/04(2006.01)i; A61C 17/022(2006.01)i

According to International Patent Classification (IPC) or to both national classification and IPC

B. FIELDS SEARCHED

Minimum documentation searched (classification system followed by classification symbols)

B01F; A61C

Documentation searched other than minimum documentation to the extent that such documents are included in the fields searched

Electronic data base consulted during the international search (name of data base and, where practicable, search terms used)

CNTXT;CNABS;DWPI;SIPOABS;CNKI:air, membrane?, gas, porous, super?fine, apparatus, +fine, bubble?, film?, generat+, liquid, device, teeth, clean+

C. DOCUMENTS CONSIDERED TO BE RELEVANT

Category*	Citation of document, with indication, where appropriate, of the relevant passages	Relevant to claim No.
X	JP 2002301345 A (SASAKI TERUJI) 15 October 2002 (2002-10-15) description, paragraphs [0014]-[0019]	1-18, 21-22
Y	JP 2002301345 A (SASAKI TERUJI) 15 October 2002 (2002-10-15) description, paragraphs[0014]-[0019]	19-20
Y	TW 201513835 A (CHANG SZU-CHUNGET AL.) 16 April 2015 (2015-04-16) abstract	19-20
A	KR 101179885 B1 (GKOXY CO LTD) 17 September 2012 (2012-09-17) the whole document	1-22
A	US 2014072502 A1 (ENOMURA MASAKAZUET AL.) 13 March 2014 (2014-03-13) the whole document	1-22
A	JP 2007000846 A (MATSUSHITA ELECTRIC WORKS LTD) 11 January 2007 (2007-01-11) the whole document	1-22

 Further documents are listed in the continuation of Box C. See patent family annex.

* Special categories of cited documents:

“A” document defining the general state of the art which is not considered to be of particular relevance

“E” earlier application or patent but published on or after the international filing date

“L” document which may throw doubts on priority claim(s) or which is cited to establish the publication date of another citation or other special reason (as specified)

“O” document referring to an oral disclosure, use, exhibition or other means

“P” document published prior to the international filing date but later than the priority date claimed

“T” later document published after the international filing date or priority date and not in conflict with the application but cited to understand the principle or theory underlying the invention

“X” document of particular relevance; the claimed invention cannot be considered novel or cannot be considered to involve an inventive step when the document is taken alone

“Y” document of particular relevance; the claimed invention cannot be considered to involve an inventive step when the document is combined with one or more other such documents, such combination being obvious to a person skilled in the art

“&” document member of the same patent family

Date of the actual completion of the international search

28 March 2016

Date of mailing of the international search report

06 April 2016

Name and mailing address of the ISA/CN

STATE INTELLECTUAL PROPERTY OFFICE OF THE
P.R.CHINA
6, Xitucheng Rd., Jimen Bridge, Haidian District, Beijing
100088, China

Authorized officer

XU,Xuefeng

Facsimile No. (86-10)62019451

Telephone No. (86-10)62084843

INTERNATIONAL SEARCH REPORT
Information on patent family members

International application No.

PCT/CN2015/082901

Patent document cited in search report			Publication date (day/month/year)	Patent family member(s)			Publication date (day/month/year)
JP	2002301345	A	15 October 2002	None			
TW	201513835	A	16 April 2015	None			
KR	101179885	B1	17 September 2012	None			
US	2014072502	A1	13 March 2014	WO	2012164652	A1	06 December 2012
				CN	103534014	A	22 January 2014
				EP	2716352	A4	05 November 2014
				KR	20140015465	A	06 February 2014
				EP	2716352	A1	09 April 2014
JP	2007000846	A	11 January 2007	JP	4631561	B2	23 February 2011