



INTERNATIONAL APPLICATION PUBLISHED UNDER THE PATENT COOPERATION TREATY (PCT)

<p>(51) International Patent Classification <sup>6</sup> : <b>H01M 8/10, 8/24</b></p>	<p><b>A1</b></p>	<p>(11) International Publication Number: <b>WO 99/27599</b></p> <p>(43) International Publication Date: 3 June 1999 (03.06.99)</p>
<p>(21) International Application Number: PCT/US98/21769</p> <p>(22) International Filing Date: 15 October 1998 (15.10.98)</p> <p>(30) Priority Data: 08/979,853 20 November 1997 (20.11.97) US</p> <p>(71) Applicant: AVISTA LABS [US/US]; 1411 East Mission, Spokane, WA 99220-3727 (US).</p> <p>(71)(72) Applicant and Inventor: FUGLEVAND, William, A. [US/US]; 8025 E. Woodview Drive, Spokane, WA 99212 (US).</p> <p>(72) Inventors: BAYYUK, Shiblihanna, I.; 2703 E. 38th Avenue, Spokane, WA 99223 (US). LLOYD, Greg, A.; 12822 E. 23rd Avenue, Spokane, WA 99216 (US). DEVRIES, Peter, D.; 8323 W. Jackson Avenue, Spokane, WA 99204 (US). LOTT, David, R.; N. 2215 Washington, Spokane, WA 99205 (US). SCARTOZZI, John, P.; 13721 East 25th Avenue, Spokane, WA 99216 (US). SOMERS, Gregory, M.; 5900 N. Starr Road, Newman Lake, WA 99025 (US). STOKES, Ronald, G.; S. 2004 Century Court, Veradale, WA 99037 (US).</p>		<p>(74) Agents: GRIGEL, George, G. et al.; Suite 1300, 601 West First Avenue, Spokane, WA 99201-3828 (US).</p> <p>(81) Designated States: AL, AM, AT, AU, AZ, BA, BB, BG, BR, BY, CA, CH, CN, CU, CZ, DE, DK, EE, ES, FI, GB, GD, GE, GH, GM, HR, HU, ID, IL, IS, JP, KE, KG, KP, KR, KZ, LC, LK, LR, LS, LT, LU, LV, MD, MG, MK, MN, MW, MX, NO, NZ, PL, PT, RO, RU, SD, SE, SG, SI, SK, SL, TJ, TM, TR, TT, UA, UG, UZ, VN, YU, ZW, ARIPO patent (GH, GM, KE, LS, MW, SD, SZ, UG, ZW), Eurasian patent (AM, AZ, BY, KG, KZ, MD, RU, TJ, TM), European patent (AT, BE, CH, CY, DE, DK, ES, FI, FR, GB, GR, IE, IT, LU, MC, NL, PT, SE), OAPI patent (BF, BJ, CF, CG, CI, CM, GA, GN, GW, ML, MR, NE, SN, TD, TG).</p> <p><b>Published</b> <i>With international search report.</i></p>

(54) Title: A PROTON EXCHANGE MEMBRANE FUEL CELL POWER SYSTEM

(57) Abstract

A proton exchange membrane fuel cell power system for producing electrical power is described and which includes a plurality of discrete fuel cell modules (100) having at least two membrane electrode diffusion assemblies (150), each of the membrane electrode diffusion assemblies having opposite anode (153) and cathode (154) sides; a pair of current collectors (190) individually disposed in juxtaposed ohmic electrical contact with opposite sides of the membrane electrode diffusion assemblies; and individual force application assemblies (200) applying a given force to the pair of current collectors and the individual membrane electrode diffusion assemblies. The proton exchange fuel cell power system also includes an enclosure mounting a plurality of subracks which receive the discrete fuel cell modules. Additionally, a control system is disclosed which optimizes the performance parameters of the discrete proton exchange fuel cell modules.

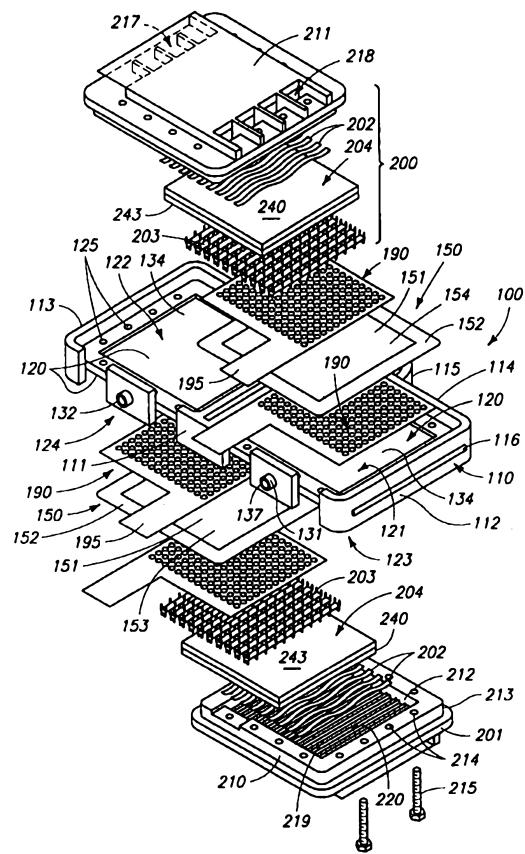

**FOR THE PURPOSES OF INFORMATION ONLY**

Codes used to identify States party to the PCT on the front pages of pamphlets publishing international applications under the PCT.

AL	Albania	ES	Spain	LS	Lesotho	SI	Slovenia
AM	Armenia	FI	Finland	LT	Lithuania	SK	Slovakia
AT	Austria	FR	France	LU	Luxembourg	SN	Senegal
AU	Australia	GA	Gabon	LV	Latvia	SZ	Swaziland
AZ	Azerbaijan	GB	United Kingdom	MC	Monaco	TD	Chad
BA	Bosnia and Herzegovina	GE	Georgia	MD	Republic of Moldova	TG	Togo
BB	Barbados	GH	Ghana	MG	Madagascar	TJ	Tajikistan
BE	Belgium	GN	Guinea	MK	The former Yugoslav Republic of Macedonia	TM	Turkmenistan
BF	Burkina Faso	GR	Greece	ML	Mali	TR	Turkey
BG	Bulgaria	HU	Hungary	MN	Mongolia	TT	Trinidad and Tobago
BJ	Benin	IE	Ireland	MR	Mauritania	UA	Ukraine
BR	Brazil	IL	Israel	MW	Malawi	UG	Uganda
BY	Belarus	IS	Iceland	MX	Mexico	US	United States of America
CA	Canada	IT	Italy	NE	Niger	UZ	Uzbekistan
CF	Central African Republic	JP	Japan	NL	Netherlands	VN	Viet Nam
CG	Congo	KE	Kenya	NO	Norway	YU	Yugoslavia
CH	Switzerland	KG	Kyrgyzstan	NZ	New Zealand	ZW	Zimbabwe
CI	Côte d'Ivoire	KP	Democratic People's Republic of Korea	PL	Poland		
CM	Cameroon	KR	Republic of Korea	PT	Portugal		
CN	China	KZ	Kazakstan	RO	Romania		
CU	Cuba	LC	Saint Lucia	RU	Russian Federation		
CZ	Czech Republic	LI	Liechtenstein	SD	Sudan		
DE	Germany	LK	Sri Lanka	SE	Sweden		
DK	Denmark	LR	Liberia	SG	Singapore		
EE	Estonia						

## DESCRIPTION

### A PROTON EXCHANGE MEMBRANE FUEL CELL POWER SYSTEM

#### Technical Field

The present invention relates to a proton exchange membrane (PEM) fuel  
5 cell power system, and more specifically to a power system which includes a  
plurality of discrete fuel cell modules producing respective voltages, and wherein  
the discrete fuel cell modules are self humidifying, have an electrical efficiency  
of at least about 40%, and offer plant reliability, ease-of-maintenance, and  
reduced capital costs not possible heretofore.

#### 10 Background Art

The fuel cell was developed in England more than 150 years ago by Sir  
William Grove in 1839. The inventor called it a "gaseous battery" at the time  
to distinguish the fuel cell from another invention of his, the electric storage  
battery. The fuel cell is an electrochemical device which reacts hydrogen and  
15 oxygen which is usually supplied from the air, to produce electricity and water.  
With prior processing, a wide range of fuels, including natural gas and coal-  
derived synthetic fuels can be converted to electric power. The basic process  
is highly efficient, and for those fuel cells fueled directly by hydrogen, pollution  
free. Further, since fuel cells can be assembled into stacks, of varying sizes,  
20 power systems have been developed to produce a wide range of output levels  
and thus satisfy numerous kinds of end-use applications.

Heretofore, fuel cells have been used as alternative power sources in earth  
and space applications. Examples of this use are unattended communications  
repeaters, navigational aids, space vehicles, and weather and oceanographic  
25 stations, to name but a few.

Although the basic process is highly efficient and pollution free, a  
commercially feasible power system utilizing this same technology has remained  
elusive. For example, hydrogen-fueled fuel cell power plants based on Proton  
Exchange Membrane (PEM) Fuel Cells are pollution free, clean, quiet on site,  
30 and have few moving parts. Further, they have a theoretical efficiency of up  
to about 80%. This contrasts sharply with conventional combustion technologies  
such as combustion turbines, which convert at most 50% of the energy from  
combusting fuel into electricity and in smaller generation capacities, are  
uneconomical and significantly less efficient.

35 Although the fundamental electrochemical processes involved in all fuel  
cells are well understood, engineering solutions have proved elusive for making

certain fuel cell types reliable and for other types, economical. In the case of PEM fuel cells, reliability has not been the driving concern to date, but rather the installed cost per watt of generation capacity has. In order to lower the PEM fuel cost per watt, much attention has been placed on increasing power  
5 output. Historically this has resulted in additional, sophisticated balance-of-plant systems necessary to optimize and maintain high PEM fuel cell power outputs. A consequence of highly complex balance-of-plant systems is they do not readily scale down to low (single residence) generation capacity plants. Consequently installed cost, efficiency, reliability and maintenance expenses all are adversely  
10 effected in low generation applications.

As earlier noted, a fuel cell produces an electromotive force by reacting fuel and oxygen at respective electrode interfaces which share a common electrolyte. In the case of a PEM fuel cell, hydrogen gas is introduced at a first electrode where it reacts electrochemically in the presence of a catalyst to  
15 produce electrons and protons. The electrons are circulated from the first electrode to a second electrode through an electrical circuit connected between the electrodes. Further, the protons pass through a membrane of solid, polymerized electrolyte (a proton exchange membrane or PEM) to the second electrode. Simultaneously, an oxidant, such as oxygen gas, (or air), is introduced  
20 to the second electrode where the oxidant reacts electrochemically in the presence of the catalyst and is combined with the electrons from the electrical circuit and the protons (having come across the proton exchange membrane) thus forming water and completing the electrical circuit. The fuel-side electrode is designated the anode and the oxygen-side electrode is identified as the cathode.  
25 The external electric circuit conveys electrical current and can thus extract electrical power from the cell. The overall PEM fuel cell reaction produces electrical energy which is the sum of the separate half cell reactions occurring in the fuel cell less its internal losses.

Since a single PEM fuel cell produces a useful voltage of only about 0.45  
30 to about 0.7 volts D.C. under a load, practical PEM fuel cell plants have been built from multiple cells stacked together such that they are electrically connected in series. In order to reduce the number of parts and to minimize costs, rigid supporting/conducting separator plates often fabricated from graphite or special metals have been utilized. This is often described as bipolar construction. More  
35 specifically, in these bipolar plates one side of the plate services the anode, and the other the cathode. Such an assembly of electrodes, membranes, and the

bipolar plates are referred to as a stack. Practical stacks have heretofore consisted of twenty or more cells in order to produce the direct current voltages necessary for efficient inverting to alternating current.

The economic advantages of designs based on stacks which utilize bipolar  
5 plates are compelling. However, this design has various disadvantages which have detracted from its usefulness. For example, if the voltage of a single cell in a stack declines significantly or fails, the entire stack, which is held together in compression with tie bolts, must be taken out of service, disassembled, and repaired. In traditional fuel cell stack designs, the fuel and oxidant are directed  
10 by means of internal manifolds to the electrodes. Cooling for the stack is provided either by the reactants, natural convection, radiation, and possibly supplemental cooling channels and/or cooling plates. Also included in the prior art stack designs are current collectors, cell-to-cell seals, insulation, piping, and various instrumentation for use in monitoring cell performance. The fuel cell  
15 stack, housing, and associated hardware make up the operational fuel cell plant. As will be apparent, such prior art designs are unduly large, cumbersome, and quite heavy. Certainly, any commercially useful PEM fuel cell designed in accordance with the prior art could not be manipulated by hand because of these characteristics.

20 It is well known that PEM fuel cells can operate at higher power output levels when supplemental humidification is made available to the proton exchange membrane (electrolyte). Humidification lowers the resistance of proton exchange membranes to proton flow. Supplemental water can be introduced into the hydrogen or oxygen streams or more directly to the proton exchange membrane  
25 by means of the physical phenomena of wicking. The focus of investigation in recent years has been to develop Membrane/Electrode Assemblies (MEAs) with increasingly improved power output when running without supplemental humidification (self-humidified). Being able to run an MEA when it is self-humidified is advantageous because it decreases the complexity of the balance-of-  
30 plant and its attendant costs. However, self-humidification heretofore has resulted in fuel cells running at lower current densities, and thus, in turn, has resulted in more of these assemblies being required in order to generate a given amount of power. This places added importance on reducing the cost of the supporting structures, such as the bipolar plates, in conventional designs.

35 Accordingly, a proton exchange membrane fuel cell power system which achieves the benefits to be derived from the aforementioned technology but

which avoids the detriments individually associated therewith, is the subject matter of the present invention.

#### SUMMARY OF THE INVENTION

5 One aspect of the present invention is to provide a proton exchange membrane fuel cell power system having a plurality of discrete PEM fuel cell modules with individual membrane electrode diffusion assemblies, the PEM fuel cell modules further having individual force application assemblies for applying a given force to the membrane electrode diffusion assemblies. Further, the PEM  
10 fuel cell modules of the present invention can be easily manipulated by hand.

Another aspect of the present invention is to provide a PEM fuel cell module which, in operation, produces a given amount of heat energy, and wherein the same PEM fuel cell module has a cathode air flow which removes a preponderance of the heat energy generated by the PEM fuel cell module.

15 Another aspect of the present invention is to provide a proton exchange membrane fuel cell power system wherein each of the discrete PEM fuel cell modules has opposing membrane electrode diffusion assemblies having a cumulative active area of at least about 60 square centimeters, and wherein each of the discrete fuel cell modules produce a current density of at least about 350  
20 mA per square centimeter of active area at a nominal voltage of about 0.5 volts D.C.; and a power output of at least about 10.5 watts.

Still a further aspect of the present invention relates to a proton exchange membrane fuel cell power system which includes an enclosure defining a cavity; and a subrack mounted in the cavity and supporting the plurality of  
25 discrete proton exchange membrane fuel cell modules.

Another aspect of the present invention relates to a proton exchange membrane fuel cell power system which comprises:

a hydrogen distribution frame defining discrete cavities, and wherein individual membrane electrode diffusion assemblies are sealably mounted in each  
30 of the cavities, the membrane electrode diffusion assemblies each having opposite anode and cathode sides; and

a pair of current collectors received in each of the cavities, the individual current collectors positioned in ohmic electrical contact with the respective anode and cathode sides of each of the membrane electrode diffusion assemblies.

35 A further aspect of the present invention relates to a proton exchange membrane fuel cell power system comprising:

a cathode cover which partially occludes the respective cavities of the hydrogen distribution frame, the respective cathode covers individually releasably cooperating with each other, and with the hydrogen distribution frame; and

a pressure transfer assembly received in each of the cavities and applying  
5 a given force to the current collectors and the membrane electrode diffusion assembly, and wherein the cathode cover is disposed in force transmitting relation relative to the pressure transfer assembly.

A further aspect of the present invention relates to a proton exchange membrane fuel cell power system which includes a membrane electrode diffusion  
10 assembly comprising:

a solid proton conducting electrolyte membrane which has opposite anode and cathode sides;

individual catalytic anode and cathode electrodes disposed in ionic contact with the anode and cathode sides of the electrolyte membrane; and

15 a diffusion layer borne on each of the anode and cathode electrodes and which is electrically conductive and has a given porosity.

Still another aspect of the present invention is to provide a proton exchange membrane fuel cell power system having a solid electrolyte membrane which comprises crosslinked polymeric chains having sulfonic acid groups, and  
20 wherein the crosslinked polymeric chains comprise methacrylates.

Moreover, another aspect of the present invention relates to a proton exchange membrane fuel cell power system which includes current collectors which have at least about 70% open area.

These and other aspects of the present invention will be discussed in  
25 further detail hereinafter.

#### **Brief Description of the Drawings**

The accompanying drawings serve to explain the principles of the present invention.

Figure 1 is a perspective, front elevation view of a proton exchange  
30 membrane fuel cell power system of the present invention and showing some underlying structures in phantom lines.

Figure 2 is a perspective view of a subrack employed with the present invention.

Figure 3 is a fragmentary, transverse, vertical sectional view taken from  
35 a position along line 3-3 of Figure 2.

Figure 4 is a second, fragmentary, transverse, vertical sectional view taken from a position along line 3-3 of Figure 2.

Figure 5 is a perspective view of a portion of the subrack.

Figure 6 is transverse, vertical, sectional view taken from a position along  
5 line 6-6 of Figure 2.

Figure 7A is a transverse, vertical, sectional view taken through an air mixing valve of the present invention.

Figure 7B is a transverse, vertical, sectional view taken through an air mixing valve of the present invention, and showing the valve in a second  
10 position.

Figure 8 is a longitudinal, horizontal, sectional view taken from a position along line 8-8 of Figure 2.

Figure 9 is a perspective, exploded, side elevation view of a proton exchange membrane fuel cell module utilized with the present invention, and the  
15 accompanying portion of the subrack which mates with same.

Figure 10 is a side elevation view of a hydrogen distribution frame utilized with the proton exchange membrane fuel cell module of the present invention.

Figure 11 is a perspective, side elevation view of a proton exchange membrane fuel cell module utilized with the present invention.

Figure 12 is a partial, exploded, perspective view of one form of the  
20 PEM fuel cell module of the present invention.

Figure 13 is a partial, greatly enlarged, perspective, exploded view of a portion of the PEM fuel cell module shown in Figure 12.

Figure 14 is a partial, exploded, perspective view of one form of the  
25 PEM fuel cell module of the present invention.

Figure 15 is a partial, greatly enlarged, perspective, exploded view of a portion of the PEM fuel module shown in Figure 14.

Figure 16 is a partial, exploded, perspective view of one form of the PEM fuel module of the present invention.

Figure 17 is a partial, greatly enlarged, perspective, exploded view of a  
30 portion of the PEM fuel cell module shown in Figure 16.

Figure 18 is a partial, exploded, perspective view of one form of the PEM fuel cell module of the present invention.

Figure 19 is a partial, greatly enlarged, perspective exploded view of a  
35 portion of the PEM fuel cell module shown in Figure 18.



Figure 20 is a perspective view of a pressure plate which is utilized in one form of PEM fuel cell module of the present invention.

Figure 21 is an end view of the pressure plate shown in Figure 20.

Figure 22 is a fragmentary, transverse, vertical sectional view taken through  
5 a cathode cover of the present invention and showing one form thereof.

Figure 23 is a fragmentary, transverse, vertical sectional view taken through a cathode cover of the present invention and showing an alternative form thereof.

Figure 24 is a fragmentary, transverse, vertical sectional view taken through  
10 a cathode cover of the present invention and showing an alternative form thereof.

Figure 25 is a fragmentary, transverse, vertical sectional view taken through a cathode cover of the present invention and showing an alternative form thereof.

Figure 26 is a greatly simplified, exploded view of a membrane electrode  
15 diffusion assembly of the present invention.

Figure 27 is a greatly simplified, exploded view of an alternate form of the membrane electrode diffusion assembly of the present invention.

Figure 28 is a top plan view of a current collector employed in the PEM  
20 fuel cell module of the present invention.

Figure 29 is a greatly enlarged perspective view of a pressure transfer assembly which is utilized with the present invention.

Figure 30 is a greatly simplified, schematic view of the control assembly of the present invention.

Figure 31 is a greatly simplified schematic view of a heat exchanger which  
25 is employed with the present invention.

#### **DETAILED DESCRIPTION OF THE PREFERRED EMBODIMENTS**

The proton exchange membrane (PEM) fuel cell power system of the  
30 present invention is generally indicated by the numeral 10 in Figure 1. As shown therein, the PEM fuel cell power system includes an enclosure which is generally indicated by the numeral 11, and which sits on the surface of the earth or other supporting surface 12. Enclosure 11 has left and right sidewalls 13 and 14, respectively, and front and rear surfaces 15 and 20, respectively.  
35 The enclosure has a top surface 21 which is joined to the left and right sidewalls; and front and rear surfaces respectively. First and second apertures

22 and 23 respectively are formed in the front surface 15. Further, a pair of doors which are generally designated by the numeral 24, are hingedly mounted on the front surface 15 and are operable to occlude the respective apertures 22 and 23. The enclosure 11, described above, defines a cavity 25 of given dimensions.

Occluding the aperture 23 are a plurality of subracks which are generally indicated by the numeral 30. The subracks are individually mounted in the cavity 25, and are operable to support a plurality of discrete PEM fuel cell modules in a given orientation in the cavity 25. The PEM fuel cell modules will be discussed in greater detail hereinafter. Referring now to Figure 2, each subrack 30 has a main body 31 for supporting the PEM fuel cell modules. The main body includes supporting flanges 32, which are attached by suitable fasteners to the enclosure 11. The subrack 30 has a forward edge 33 and a rearward edge 34. Further, the main body has top and bottom portions 35 and 40, respectively. A rear wall 41 (Figs. 5 and 6) joins the top and bottom portions together at the rearward edge 34. As best seen in Figure 2, a plurality of apertures 42 and 43 are formed in the top and bottom portions 35 and 40, respectively. Further, elongated channels 44 and 45 are formed in the respective top and bottom portions 35 and 40, respectively. As best understood by reference to Figures 3, 4, and 5, the main body 31 is made up of a number of discrete mirror image portions 31A, which when joined together, form the main body. This is further seen in Figure 8. These mirror image portions are fabricated from a moldable, dielectric substrate. As best seen by reference to Figures 5 and 6, a D.C. (direct current) bus 50 is affixed on the rear wall 41 of the subrack 30. A repeating pattern of 8 pairs of conductive contacts 51 are attached on the rear wall 41. Further, first and second valves 52 and 53 are appropriately positioned relative to the 8 pairs of conductive contacts 51. As best seen in Figure 6, the respective first and second valves 52 and 53 extend through the rear wall 41 and are coupled in fluid flowing relation relative to first and second conduits 54 and 55, respectively. Referring now to Figure 8, the first conduit 54 constitutes a hydrogen distribution assembly which is coupled in fluid flowing relation with a source of hydrogen 60 (Figure 1). Further, a valve assembly 61 is coupled in fluid meter relation relative to the source of hydrogen 60 and the first conduit 54. The second conduit 55 exhausts to ambient, or may be coupled in fluid flowing relation with other systems such as a hydrogen recovery and recycling system or alternatively a chemical reformer

which produces a supply of hydrogen for use by the power system 10. In this regard, the hydrogen recovery and recycling system would recover or recapture unreacted hydrogen which has previously passed through the individual PEM fuel cell modules. This system, in summary, would separate the unreacted hydrogen  
5 from other contaminants (water, nitrogen, etc.) and return it to the power system 10. In the alternative, a chemical reformer may be utilized for the purpose described above, and the unreacted hydrogen would be returned to the chemical reformer where it would again be delivered to the individual PEM fuel cell modules, as will be described in further detail below.

10 Referring now to Figure 6, the PEM fuel cell power system 10 of the present invention further includes an air distribution assembly 70 which is received in the enclosure 11 and which is coupled in fluid flowing relation relative to the subrack 30. The air distribution assembly 70 includes an air plenum which is generally indicated by the numeral 71. The air plenum 71 has  
15 a first intake end 72, and a second exhaust end 73. The exhaust end 73 is positioned intermediate the top and bottom portions 35 and 40 and delivers air to each of the PEM fuel cell modules supported on the subrack 30. Further, the intake end 72 is positioned in fluid flowing relation relative to the top and bottom portions 35 and 40 of the subrack 30.

20 An air movement ventilation assembly 74 comprising a direct current fan 75 or equivalent substitute is operably coupled to the plenum 71. The variably adjustable speed fan 75 moves air from the intake end 72 to the exhaust end 73 of the plenum 71. Referring now to Figures 6, 7A and 7B, an air mixing valve 80 is operably coupled with the air movement assembly 74, and the intake  
25 end 72 of the plenum 71. The air mixing valve 80 includes an outer tube 81 which has formed therein a pair of apertures 82 which communicate in fluid flowing relation with the air plenum 71. Still further, the air mixing valve 80 includes an inner tube 83 which is telescopingly received internally of, and substantially concentrically disposed relative to, the outer tube 81. The inner  
30 tube 83 is selectively rotatable relative to the outer tube 81. A pair of apertures 84 are formed in the inner tube and provides a convenient means by which the exhaust end 73 may be selectively coupled with the intake end 72 of the air plenum 71. Still further, it should be understood that the inner tube is connected in fluid flowing relation with ambient air which comes from outside  
35 of the plenum 71. As illustrated most clearly by references to Figure 2, an actuator, or motor 85, is disposed in force transmitting relation relative to the

air mixing valve 80 and more specifically, to the inner tube 83 thereof. The actuator 85, when energized, moves the air mixing valve 80 and more specifically, the second tube along a given course of travel 90 between a first position 91, as seen in Figure 7B, to a second open position 92, which is seen in Figure 5 7A. The movement of the air mixing valve 80 along this course of travel 90 facilitates the selective mixing of outside air with the air which has previously passed through the respective PEM fuel cell modules and which has become heated and humidified by way of the chemical reaction taking place within each of the proton exchange membrane fuel cell modules.

10 As best appreciated by a study of Figure 30, temperature sensors 93 are positioned near the exhaust end 73 of the air plenum 71 for sensing the temperature of the air entering the discrete PEM fuel cell modules and near the plenum intake end 72. The temperature sensors 93 sense the temperature of the air mixture which comprises outside ambient air, and the air which has just 15 passed through each of the discrete proton exchange membrane fuel cell modules. Still further, and as best seen in Figure 30, a control assembly 250 is electrically coupled with the temperature sensors 93, and the actuator 85. The control assembly selectively energizes the actuator 85 to move the air mixing valve 80 along the course of travel 90 to control the temperature of the air delivered at 20 the exhaust end 73 of the air plenum 71. As should be understood, the air movement assembly 74 has a speed of operation which is variably adjustable. In this regard, the control assembly is electrically coupled in controlling relation relative to the air movement assembly 74, temperature sensors 93, and the air mixing valve 80 to vary or otherwise optimize the performance characteristics of 25 the Proton Exchange Membrane (PEM) fuel cell modules under assorted operational conditions. This relationship is illustrated most accurately by a study of Figure 30.

Referring now to Figure 9, a plurality of discrete PEM fuel cell modules are generally indicated by the numeral 100, and are releasably supported on the 30 subrack 30. The description which follows relates to a single PEM fuel cell module 100, it being understood that each of the PEM fuel cell modules are substantially identical in construction, and are light in weight and can be readily manipulated or moved about by hand.

A discrete PEM fuel cell module 100 is best illustrated by reference to 35 Figures 9 and 11 respectively. Referring now to Figure 10, each PEM fuel cell module 100 includes a hydrogen distribution frame which is generally indicated

by the numeral 110. The hydrogen distribution frame 110 is fabricated from a substrate which has a flexural modulus of less than about 500,000 pounds per square inch, and a compressive strength of less than about 20,000 pounds per square inch. As such, any number of suitable or equivalent thermoplastic materials can be utilized. The hydrogen distribution frame 110 includes a main body 111 as seen in Figure 10. The main body has a first end 112, and an opposite second end 113. Further, the main body is defined by a peripheral edge 114. Positioned in a given location along the peripheral edge is a handle 115 which facilitates the convenient manual manipulation of the PEM fuel cell module 100. An elongated guide member or spine 116 is located on the first and second ends 112 and 113 respectively. Each spine 116 is operable to be matingly received in, or cooperate with, the respective elongated channels 44 and 45 which are formed in the top and bottom portions 35 and 40 of the subrack 30 (Figure 9). As should be understood, the alignment and mating receipt of the individual spines 116 in the respective channels allows the individual PEM fuel cell modules 100 to be slidably received and positioned in predetermined spaced relation, one to the other, on the subrack 30. Such is seen most clearly by reference to Figure 2. When received on the subrack 30, the exhaust end 73 of the air plenum 71 is received between two adjacent PEM fuel cell modules 100.

As seen in Figure 10, the main body 111 defines a plurality of substantially opposed cavities 120. These cavities are designated as first, second, third, and fourth cavities 121, 122, 123, and 124 respectively. Still further, and referring again to Figure 10, a plurality of apertures 125 are formed in given locations in the main body 111 and are operable to receive fasteners which will be discussed in further detail hereinafter. The main body 111 further defines a pair of passageways designated generally by the numeral 130. The pair of passageways include a first passage 131 which permits the delivery of hydrogen gas from the source of same 60, to each of the cavities 121-124; and a second passageway 132 which facilitates the removal of impurities, water and unreacted hydrogen gas from each of the cavities 121-124. A linking passageway 133 operably couples each of the first and second cavities 121, and 122, and the third and fourth cavities 123 and 124 in fluid flowing relation one to the other, such that hydrogen gas delivered by means of the first passageway 131 may find its way into each of the cavities 121-124. Each of the cavities 121 through 124 are substantially identical in their overall dimensions and shape. Still further,

each cavity has a recessed area 134 having a given surface area and depth. Positioned in the recessed area 134 and extending substantially normally outwardly therefrom are a plurality of small projections 135. The function of these individual projections will be discussed in greater detail below. As best seen in  
5 Figure 10, the first and second passageways 131 and 132 are connected in fluid flowing relation relative to each of the recessed areas 134. Referring still to Figure 10, the peripheral edge 114 of the main body 111 is discontinuous. In particular, the peripheral edge 114 defines a number of gaps or openings 136. Referring now to Figure 11, each passageway 131 and 132 has a terminal end  
10 137 which has a given outside diametral dimension. The terminal end 137 of each passageway 130 is operable to matingly interfit in fluid flowing relation relative to the first and second valves 52 and 53 respectively.

Referring now to Figures 12, 13, 26, and 27, sealably mounted within the respective cavities 121 through 124 respectively is a membrane electrode diffusion  
15 assembly 150 which is generally indicated by the numeral 150. The membrane electrode diffusion assembly 150 has a main body or solid electrolyte membrane 151 which has a peripheral edge 152 which is sealably mounted to the hydrogen distribution frame 110. The membrane electrode diffusion assembly 150 has an anode side 153, and an opposite cathode side 154. The anode side 153 is held  
20 in spaced relation relative to hydrogen distribution frame 110 which forms the respective cavities 121-124 by the plurality of projections 135 (Figure 10). This special relationship ensures that hydrogen delivered to the respective cavities 121-124 reaches all parts of the anode side of the membrane electrode diffusion assembly 150. Electrodes 160, comprising catalytic anode and cathode electrodes  
25 161 and 162 are formed on the main body 151. These individual anode and cathode electrodes 161 and 162 are disposed in ionic contact therewith. Still further, a noncatalytic electrically conductive diffusion layer 170 is affixed on the anode and cathode electrodes 160 and has a given porosity. As best illustrated in Figure 26, the noncatalytic electrically conductive diffusion layer 170 has a  
30 first diffusion layer 171 which is positioned in ohmic electrical contact with each of the electrodes 161 and 162 respectively, and a second diffusion layer 172 which is positioned in ohmic electrical contact with the underlying first diffusion layer. As best seen in Figure 27, a second form of the membrane electrode diffusion assembly 150 is shown and wherein a third diffusion layer 173 is  
35 provided. In this form, the third layer is affixed to the main body 151 prior to affixing the first and second diffusion layers thereto. In this regard, a

number of commercially available membrane electrode assemblies are fabricated which have a preexisting proprietary diffusion layer attached to same, the composition of which is unknown to the inventors.

Referring now to Figure 26, the membrane electrode diffusion assembly  
5 150 and more specifically, the first diffusion layer 171 which is affixed thereto comprises a coating of particulate carbon suspended in a binding resin. Further, the second diffusion layer 172 comprises preferably a porous hydrophobic carbon backing layer. With respect to the binding resin, it is substantially hydrophobic and is selected from the group consisting essentially of perfluorinated  
10 hydrocarbons or a substitute equivalent. Further, the first diffusion layer 171 has about 20% to about 90% by weight of particulate carbon. With respect to the second diffusion layer 172, it is selected from the group consisting essentially of carbon cloth, carbon paper, or carbon sponge or a substitute equivalent which has been rendered hydrophobic. In the preferred form of the invention, the  
15 first diffusion layer 171 is a composite coating formed of successive layers of the first diffusion layer, each of the successive layers having a given hydrophobicity. Additionally, the first diffusion layer 171 has a hydrophobic gradient. This gradient can be altered by adjusting the hydrophobicity of the successive layers that form the composite coating. Depending upon the desired performance  
20 parameters of the membrane electrode diffusion assembly 150 that is employed, the successive layers closest to the second diffusion layer 172 may be the least hydrophobic of all the successive layers, or the most hydrophobic. To affix the first and second diffusion layers 171 and 172 to the underlying anode and cathode electrodes 161 and 162, a thermoplastic binding agent can be utilized  
25 and which is selected from the group consisting essentially of polyethylene or wax, or a substitute equivalent. Still further, these same layers may be attached by pressure and heat. In the preferred form of the invention, the individual anode and cathode electrodes 161 and 162 comprise particulate carbon; a catalyst such as platinum or the like; and a crosslinked copolymer incorporating sulfonic  
30 acid groups.

The method of forming the first and second diffusion layers 171 and 172, as described above, is discussed in the paragraphs which follow. The method of forming a diffusion layer 170 for use with a membrane electrode diffusion assembly 150 comprises as a first step, providing a carbon backing layer  
35 constituting a second diffusion layer 172. The carbon backing layer is selected from the group consisting essentially of carbon cloth, carbon paper, or carbon

sponge. The subsequent steps in the method comprises applying a hydrophobic polymer to the carbon backing layer constituting the second diffusion layer 172; and sintering the carbon backing layer constituting the second diffusion layer at a temperature greater than the melting point of the hydrophobic polymer. As  
5 discussed above, the hydrophobic polymer is selected from the group consisting essentially of perfluorinated hydrocarbons or a substitute equivalent. Still further, in the method as described, the sintering step takes place at a temperature of about 275 degrees to about 365 degrees C. The preferred method of forming the diffusion layer 170 for use with the membrane electrode diffusion assembly  
10 150 comprises providing a porous carbon backing layer constituting the second diffusion layer 172; and applying a porous coating comprising a slurry of particulate carbon, a binding resin and a delivery fluid which is applied on the porous carbon backing layer. The porous carbon backing layer constituting the second diffusion layer 172 is the same as was described above. Further, the  
15 binding resin is hydrophobic and may include perfluorinated hydrocarbons. The porous coating comprises at least about 20% to about 90% by weight of the particulate carbon. The delivery fluid utilized to form the slurry of particulate carbon and the binding resin comprises water, and a compatible surfactant. In this regard, the delivery fluid consists essentially of about 95% to about 99% by  
20 weight of water; and about 1% to about 5% by weight of the compatible surfactant. The surfactant is selected from the group consisting essentially of ammonium hydroxide and/or alcohol. In the examples which follow, the delivery fluid utilized consists of a solution of 2-butoxyethanol and ammonium hydroxide as the surfactants. A solution such as this may be commercially secured. In  
25 the present instance, the inventors used a commercially available cleaner with properties such as "Windex". Windex is the registered trademark of S.C. Johnson and Sons. After the delivery of the slurry which includes the binding resin and particulate carbon, the method further comprises removing the delivery fluid thereby leaving behind or depositing the particulate carbon and the binding resin  
30 on the porous carbon backing layer constituting the first diffusion layer 171. The delivery fluid is removed by applying heat energy to same which facilitates the evaporation of the delivery fluid.

In another alternative form of the invention, the binding resin and porous carbon coating slurry as described above, may be applied in successive coats  
35 thereby creating a hydrophobic gradient. This hydrophobic gradient, as earlier discussed, may be adjusted by altering the hydrophobicity of each of the



successive coats. To achieve this adjustable hydrophobic gradient, binding resins are selected from the group consisting essentially of hydrophobic and hydrophilic binding resins or a substitute equivalent. As should be appreciated, the given hydrophobicity of each coat forming the composite first diffusion layer 171 may  
5 be adjusted by providing a predetermined mixture of the hydrophobic and hydrophilic binding resins in the resulting slurry or by altering the proportional relationship of the components. As was discussed above, each of the coatings of the composite first diffusion layer 171 which are applied closest to the porous carbon backing layer may be the most hydrophilic or the least hydrophilic  
10 depending upon the performance characteristics desired for the membrane electrode diffusion assembly 150. Still further, the method may include a sintering step whereby the resulting diffusion layer 170 is sintered at a temperature effective to melt the binding resin and create a substantially homogeneous surface. In addition to the foregoing, the method further  
15 comprises, after the sintering step, applying a predetermined pattern of pressure of a given value to the diffusion layer 171, and which is effective to vary the porosity of the resulting diffusion layer 170. As was discussed above, the diffusion layer 170 may be attached to the underlying catalytic anode and cathode electrodes 162 and 163 respectively by utilizing a thermoplastic binding  
20 emulsion which is selected from the group consisting essentially of polyethylene or wax or alternatively by utilizing heat and pressure.

The diffusion layer 170, described above, is useful in managing the water which is generated as a result of the chemical reaction taking place in each of the PEM fuel cell modules 100. In this regard, the inventors have discovered  
25 that the diffusion layer 170 allows sufficient water to escape from the cathode side of the membrane electrode diffusion assembly 150 such that the PEM fuel cell module 100 does not "flood out" with water thereby inactivating same. On the other hand, the hydrophobic gradient, as described above, facilitates the retention of sufficient moisture such that the PEM fuel cell module 100 becomes  
30 self-humidifying, that is, sufficient water is retained in the membrane electrode diffusion assembly 150 such that it achieves substantially the maximum current density possible without the addition of extra moisture or humidification from outside of the PEM fuel cell module 100. Still further, the air distribution assembly 70 and air mixing valve 80 provides a convenient means by which  
35 outside ambient air may be added to air which has previously passed through each of the PEM fuel cell modules 100 thereby maintaining the PEM fuel cell

modules 100 in a properly humidified state. As should be understood, this mixing of air effectively removes water from the cathode side of membrane electrode diffusion assembly 150. Additionally, the same mixing of air effectively removes heat energy which is a by-product of the chemical reaction taking place  
5 in each of the PEM fuel cell modules 100 and thus maintains the PEM fuel cell modules at a stable temperature. In this regard, the air delivered at the exhaust end 73 of the air plenum 71 constitutes the cathode air flow, and in the present invention 10 a novel feature of the power system 10 is that a preponderance of the heat energy produced by each of the PEM cell modules  
10 100 is removed from same by this cathode air flow.

Examples of forming the diffusion layer 170 on an underlying main body 151 of the membrane electrode diffusion assembly 150 is set forth below.

The examples set forth hereinafter relate to the fabrication of the diffusion layer 170 as seen in Figures 26 and 27, respectively.

15

#### General Test Procedures

A hydrogen/air fuel cell test fixture was fabricated from a two-part stainless steel fixture which encloses a 4 cm x 4 cm proton conductivity membrane electrode diffusion assembly (MEDA) for testing. The hydrogen side  
20 of the block (anode) defines a cavity which contains a flat, perforated ceramic plate. Pressure conditions effective to affix top of this plate is a matching perforated platinum coated nickel current collector. Hydrogen gas passes into the anode half of the stainless steel fixture, through the holes in the ceramic plate and the associated current collector. The hydrogen is thus able to reach  
25 the anode of the MEDA, which is placed on top of the anode current collector.

The proton-conducting MEDA, which is purchased from the W.L. Gore Company under the trade designation Primea 6000 Series is larger than the electrodes which are affixed to same, the MEDA, having dimensions of about 5 cm x 5 cm. This allows for the placement of a sealing gasket around the  
30 periphery of the electrodes when the stainless steel test fixture is bolted together.

The cathode side of the test fixture also defines a cavity which matingly receives a perforated ceramic plate and current collector. However, the stainless steel fixture does not press the current collector against the MEDA directly.  
35 Instead, five screws are mounted on the test fixture cathode side. These screws press against a perforated metal pressure plate. The plate has apertures which

are substantially coaxially aligned with the holes formed in the ceramic plate. These screws further press against the ceramic plate and the current collector. By threadably advancing the screws, the current collector contact pressure relative to the MEDA can be selectively adjusted after the stainless steel test fixture has  
5 been bolted together.

A supply of air is provided at the cathode, by means of several holes which have been machined into the stainless steel fixture between the aforementioned pressure screws. This allows air to travel past the screws and the perforated steel pressure plate, ceramic plate, and current collector to the  
10 cathode side of the MEDA.

The test MEDAs were placed over the cathode of the test fixture along with a sealing gasket. The test fixture is then bolted together. The pressure screws are then threadably advanced until sufficient force has been generated at the current collector cathode/anode interfaces for good electrical contact. Once  
15 this has been accomplished, the hydrogen gas is supplied at a pressure of about 5 PSI. The anode side of the MEDA is then purged of any air. A supply of fresh air is then supplied to the cathode side of the MDEA by means of a fan or the like. The supply of air had a dewpoint of 15 degrees Celsius.

Electrical performance is tested by loading the fuel cell with a variety of  
20 resistors. Since the resistor values are known, the current can be computed by examining the voltage across the resistors. MEDAs are initially short-circuited to condition them, and then are allowed to stabilize at a given load of usually about 0.6 volts. When a steady-state power output has been obtained, the data is gathered.

For comparative testing, the diffusion layers 170 which are affixed on the  
25 cathode and anode sides of MEDA are often dissimilar. A PEM fuel cell's electrical performance is largely unaffected when the configuration of the anode diffusion layer is changed. However, the diffusion layer placed on the cathode side of the MEA, on the other hand, has a significant impact on the electrical  
30 performance of the PEM fuel cell because water production, and evaporation of same, must occur on the cathode side of the MEDA. As earlier noted, the fabrication method described above includes subjecting the diffusion layer 170 to given temperature and pressure conditions effective to affix the diffusion layer 170 to the underlying MEA thus forming the MEDA. In this regard, the same  
35 pressure is applied to the cathode and anode sides of the MEDA. The most accurate comparison between two different diffusion layers made by the foregoing

methods is done by using a single MEDA. In this regard, comparative testing between dissimilar layers is done by simply flipping the MEDA over in the test fixture, thus reversing the anode and cathode sides of the MEDA. Therefore, the same MEDA is tested with different diffusion layers acting as the cathode.

5

#### EXAMPLE 1

A sheet of carbon paper (Toray TGP-H-060) was dipped into a solution of 2:3 Teflon-120 (Dupont) and deionized water for several minutes. Teflon-120 is a hydrophobic polymer comprising polytetrafluoroethylene. Teflon-120 is a trade  
10 designation of the E.I. Dupont Company. After removal from the solution the carbon paper was allowed to dry in a horizontal position on top of an open cell foam sponge. The carbon paper was then placed in an air-filled sintering oven (360 °C) for 3-5 minutes. This rendered the carbon paper hydrophobic.

#### 15 Diffusion Layer Side "A".

A solution comprising water, and a compatible surfactant was then prepared. In this regard, 200 ml of a commercially available cleaner "Windex" was mixed with 4.2 g Vulcan XC-72R (Cabot) particulate carbon powder. The mixture was sonicated for 90 seconds at a power of about 200 watts, using a  
20 stir-bar to agitate the mixture during sonication and create a slurry. After sonication, 1 ml of a hydrophobic polymer, Teflon-30 (Dupont), was added. The slurry was then sprayed onto the carbon paper with an air brush using multiple passes. Once the carbon paper was wetted with the solution, it was placed on a hot plate to evaporate the solution comprising the water and surfactant. The  
25 spraying/drying process was then repeated. As will be appreciated, the process of evaporation deposited the particulate carbon and associated binding resin until a final (dried) added weight of  $6.4 \text{ mg/cm}^2$  had been achieved. Finally, the coated carbon paper was loaded into the air-filled sintering oven at 360 °C for 3-5 minutes. This sintering melted the binding resin and created a substantially  
30 homogeneous surface.

#### Diffusion Layer Side "B".

Side "B" was fabricated in approximately the same manner as side "A" described above. However, side "B" was placed into a press for 10 seconds and  
35 was subjected to three tons of force. An irregular surface was placed on top of the diffusion layer side "B" prior to subjecting it to pressure. In the present

test a 150-grit sandpaper with an aluminum foil spacer sheet was utilized. The spray-on side faced the sandpaper/foil during the pressing stress.

#### MEA Fabrication:

5 The diffusion layers were affixed to a commercially available membrane electrode diffusion assembly such as that which may be secured from the W. L. Gore Company under the trade designation Primea Series 6000. This was done by placing the assembly in a hot press. The MEDA was hot pressed several times using successively higher pressures. Data was taken between successive  
10 presses.

#### Results:

Each sample was loaded into the test fixture described above. Temperatures were measured at the diffusion layer surface and were within a  
15 range of +/- 2 °C. These temperatures were controlled by varying the cathode air flow. Values are current density as expressed in mA/cm<sup>2</sup> at 0.6 volts. Sides "A" and "B" as noted below refer to that side acting as the cathode.

Press Method	36 °C		45 °C		53 °C	
	A	B	A	B	A	B
3.5 tons, 190 °C, 20 sec	-	-	-	-	-	-
4 tons, 190 °C, 20 sec	318	319	293	325	277	316
4.5 tons, 180 °C, 30 sec	372	363	350	353	322	322
5 tons, 180 °C, 30 sec	399	371	363	374	319	361
25 5.5 tons, 180 °C, 30 sec	338	363	375	394	-	-
6 tons, 170 °C, 40 sec	269	250	356	380	363	354

Conclusions: The patterned-press (side "B") yields slightly better or equal  
30 performance at 45 °C and 53 °C at 8 of the 9 comparative data points. Good performance is also obtained with side "A".

**EXAMPLE 2**

A sheet of carbon paper (Toray TGP-H-060) was dipped into a solution of 2:3 Teflon-120 (Dupont) and deionized water solution for several minutes. As earlier noted, Teflon-120 is a trade designation of E.I. Dupont Company. 5 After removal from the solution the carbon paper was allowed to dry in a horizontal position on top of an open cell foam sponge. The carbon paper was then placed in an air-filled sintering oven (360 °C) for 3-5 minutes. The heat energy melted the polytetrafluoroethylene (Teflon-120) thus making a substantially homogeneous surface. This sintering rendered the carbon paper hydrophobic.

10

**Diffusion layer side "A":**

A slurry was then prepared utilizing water and a compatible surfactant such as ammonia or the like. In the present example the slurry was prepared by mixing 200 ml of a commercially available cleaner "Windex" with 4.2 g Vulcan 15 XC-72R (Cabot) particulate carbon powder. The slurry was then sonicated for 90 seconds at a power of about 200 watts, using a stir-bar to agitate the slurry during sonication. After sonication, 1 ml of hydrophobic polymer solution Teflon-30 (Dupont) was added. The slurry was then sprayed onto the carbon paper with an air brush using multiple passes as was described earlier. Once the 20 carbon paper had been wetted with the slurry, it was placed on a hot plate to evaporate the solution of water and surfactant. The spraying/drying process was then repeated until a final (dried) added weight of  $6.4 \text{ mg/cm}^2$  had been achieved. Side "B" was subsequently placed into a press for 10 seconds and subjected to three tons of force. As with the first example, an irregular surface 25 was utilized between the press and the sprayed on layers. In this example, a 150-grit sandpaper with an aluminum foil spacer sheet was employed. The spray-on side faced the sandpaper/foil combination during pressing.

**Diffusion layer side "B":**

A similar slurry was prepared by mixing 200 ml of "Windex" with 4.2 g Vulcan XC-72R (Cabot) carbon powder. The mixture was sonicated for 90 seconds at a power of about 200 watts, using a stir-bar to agitate the mixture  
5 during sonication. After sonication, a 1.2 ml solution of Teflon-30 (Dupont) was added to the slurry. The mixture was then sprayed onto the carbon paper with an air brush using multiple passes. Once the carbon paper had been wetted with the solution, it was placed on a hot plate to evaporate the water and surfactant solution (Windex). The spraying/drying process was then repeated  
10 until a final (dried) added weight of  $4.91 \text{ mg/cm}^2$  had been achieved.

A second slurry was then prepared by mixing 200 ml of "Windex" with 4.2 g Vulcan XC-72R (Cabot) carbon powder. The slurry was sonicated for 90 seconds at a power of about 200 watts, using a stir-bar to agitate the mixture during sonication. After sonication, 0.5 ml of Teflon-30 (Dupont) was added.  
15 The slurry was then sprayed onto the previously coated carbon paper with an air brush using multiple passes. Once the carbon paper had been wetted with the slurry, it was placed on a hot plate to evaporate the water and surfactant and thus deposit the hydrophobic polymer and the particulate carbon. The spraying/drying process was then repeated until a final (dried) added weight of  
20  $1.58 \text{ mg/cm}^2$  had been achieved. The total weight of the spray-on layers was  $6.5 \text{ mg/cm}^2$ . Side "B" was placed into the press for 10 seconds at 3 tons of force underneath an irregular surface (150-grit sandpaper with an aluminum foil spacer sheet). The spray-on side faced the sandpaper/foil combination during pressing.

**MEA Fabrication:**

The diffusion layers were affixed to a commercially available MEDA such as what was described in Example 1, above. This was done by placing the assembly in the hot press. The MEDA was hot pressed several times using  
5 successively higher pressures. Data was taken between successive presses.

**Results:**

Each sample was loaded into the test fixture as described earlier. Temperatures as noted below were measured at the diffusion layer surface and  
10 are within a tolerance of +/- 2 °C. The values which are set forth are expressed in mA/cm<sup>2</sup> at 0.6 volts. Sides "A" and "B" refer to that side acting as the cathode. For this sample, as identified, hot pressing involved two identical steps at the same pressure and rotating the MEDA 180 degrees between each pressing.

15

**Press Method**36 °C  
A B45 °C  
A B53 °C  
A B

Press Method	36 °C		45 °C		53 °C	
	A	B	A	B	A	B
2x3.5 tons, 170 °C, 40 s	238	219	318	219	277	244
2x4 tons, 170 °C, 40 s	263	263	331	356	331	325
20 2x4.5 tons, 170 °C, 40 s	206	206	338	344	325	356
2x5 tons, 170 °C, 40 s	219	219	325	338	325	356
2x5.5 tons, 170 °C, 40 s	188	213	263	269	244	256

25 The results demonstrate that the reverse gradient samples, when subjected to greater than 3.5 tons pressure, produces current densities which are equal to or better than the non-gradient samples in 11 of 12 comparative tests.



## EXAMPLE 3

A sheet of carbon paper (Toray TGP-H-090) was dipped into a solution of 4:9 Teflon-120 (Dupont) and deionized water for several minutes. After removal from the solution the carbon paper was allowed to dry in a horizontal position on top of an open cell foam sponge. The carbon paper was then placed in an air-filled sintering oven (360 °C) for 3-5 minutes. This rendered the carbon paper hydrophobic.

**Diffusion layer side "A":**

A slurry was then prepared by mixing 200 ml of "Windex" with 4.2 grams of Vulcan XC-72R (Cabot) carbon powder. This is identical to the previous examples. The slurry was then sonicated for 90 seconds at a power of about 200 watts, using a stir-bar to agitate the mixture during sonication. After sonication, a 1.2 ml solution of Teflon-30 (Dupont) was added to the slurry. The slurry was then sprayed onto the carbon paper with an air brush using multiple passes. Once the carbon paper had been wetted with the solution, it was placed on a hot plate to evaporate the water and surfactant solution (Windex) and thus deposit the hydrophobic polymer and particular carbon. The spraying/drying process was then repeated until a final (dried) added weight of 1.0 mg/cm<sup>2</sup> had been achieved.

A second slurry was then prepared by mixing 200 ml of "Windex" with 4.2 grams of Vulcan XC-72R (Cabot) carbon powder. The slurry was then sonicated for 90 seconds at a power of about 200 watts, using a stir-bar to agitate the mixture during sonication. After sonication, 0.5 ml of a solution of Teflon-30 (Dupont) was added. The slurry was then sprayed onto the previously coated carbon paper with an air brush using multiple passes. Once the carbon paper had been wetted with the slurry, it was placed on a hot plate

to evaporate the water and surfactant solution (Windex), and thereby deposit the hydrophobic polymer and particulate carbon. The spraying/drying process was repeated until a final (dried) added weight of  $0.5 \text{ mg/cm}^2$  had been achieved.

The total weight of the spray-on layers is approximately  $1.5 \text{ mg/cm}^2$ .

5

**Diffusion layer side "B":**

Side "B" was prepared exactly the same as side "A". However, side "B" was placed into a press for 10 seconds and subjected to three tons of force underneath an irregular surface (150-grit sandpaper with an aluminum foil spacer  
10 sheet). The spray-on side faced the sandpaper/foil combination during pressing.

**MEA Fabrication:**

The diffusion layers were affixed to a commercially available MEDA as was discussed in Example 1, above. This was done by placing the MEDA in  
15 a hot press. The MEDA was hot pressed several times using successively higher pressures. Data was taken between successive presses.

**Results:**

Each sample was loaded into the aforementioned test fixture. The  
20 temperature as noted below was measured at the diffusion layer surface and is within a tolerance of  $\pm 2 \text{ }^\circ\text{C}$ . The values below are expressed in  $\text{mA/cm}^2$  at 0.6 volts. Sides "A" and "B" refer to that side acting as the cathode. For this sample, hot pressing usually involved two identical steps at the same pressure. The MEDA was rotated about 180 degrees between each pressing.

Press Method	36 °C		45 °C		53 °C	
	A	B	A	B	A	B
2x3.5 tons, 170 °C, 40 s	-	-	-	-	-	-
2x4 tons, 170 °C, 40 s	363	316	369	338	350	319
5 2x4.5 tons, 170 °C, 40 s	363	-	363	-	325	-
2x5 tons, 170 °C, 40 s	413	-	416	-	400	-
4x5.5 tons, 170 °C, 30 s	388	-	419	-	413	-

10 The data above further confirms the novelty of the diffusion layer 170 and associated membrane electrode diffusion assembly construction 150.

#### EXAMPLE 4

##### Diffusion Layer Side "A"

15 A sheet of carbon paper (Toray TGP-H-060) was dipped into a solution of 4:9 Teflon-120 (Dupont) and deionized water for several minutes. After removal from the solution the carbon paper was allowed to dry in a horizontal position on top of an open cell foam sponge. The carbon paper was then placed in an air-filled sintering oven (360 °C) for 3-5 minutes. This sintering  
20 rendered the carbon paper hydrophobic.

A slurry was then prepared utilizing water and a compatible surfactant such as ammonia or the like. In the present example the slurry was prepared by mixing 200 ml of a commercially available cleaner "Windex" with 4.2 g Vulcan XC-72R (Cabot) carbon powder. The slurry was sonicated for 90 seconds  
25 at a power of about 200 watts, using a stir-bar to agitate the slurry during sonication. After sonication, 1.2 ml of hydrophobic polymer solution Teflon-30 (Dupont) was added. The mixture was then sprayed onto the carbon paper with an air brush using multiple passes as was described earlier. Once the carbon paper had been wetted with the slurry, it was placed on a hot plate to  
30 evaporate the solution of water and surfactant. The spraying/drying process was

then repeated until a final (dried) added weight of  $4.2 \text{ mg/cm}^2$  had been achieved.

A second slurry was then prepared by mixing 200 ml Windex with 4.2 g Vulcan XC-72R (Cabot) carbon powder. The slurry was sonicated for 90 seconds  
5 at a power of about 200 watts, using a stir-bar to agitate the slurry during sonication. After sonication, 0.5 ml of Teflon-30 (Dupont) was added. The slurry was then sprayed onto the previously coated carbon paper with an air brush using multiple passes. Once the carbon paper had been wetted with the slurry, it was placed on a hot plate to evaporate the water and surfactant. The  
10 spraying/drying process was then repeated until a final (dried) added weight of  $1.6 \text{ mg/cm}^2$  had been achieved. The total weight of the spray-on layers was  $5.8 \text{ mg/cm}^2$ .

#### **Diffusion Layer Side "B"**

15 A sheet of carbon paper (Toray TGP-H-090) was dipped into a solution of 4:9 Teflon-120 (Dupont):DI water for several minutes. After removal from the solution the carbon paper was allowed to dry in a horizontal position on top of an open cell foam sponge. The carbon paper was then placed in an air-filled sintering oven ( $360 \text{ }^\circ\text{C}$ ) for 3-5 minutes. This rendered the carbon paper  
20 hydrophobic.

A slurry was then prepared utilizing water and a compatible surfactant such as ammonia or the like. The slurry was prepared by mixing 200 ml of a commercially available cleaner "Windex" with 4.2 g Vulcan XC-72R (Cabot) carbon powder. The slurry was sonicated for 90 seconds at a power of about  
25 200 watts, using a stir-bar to agitate the slurry during sonication. After sonication, 1.2 ml of hydrophobic polymer solution Teflon-30 (Dupont) was added. The mixture was then sprayed onto the carbon paper with an air brush using

multiple passes. Once the carbon paper had been wetted with the slurry, it was placed on a hot plate to evaporate the solution of water and surfactant. The spraying/drying process was then repeated until a final (dried) added weight of 1.0 mg/cm<sup>2</sup> had been achieved.

5 A second slurry was then prepared by mixing 200 ml Windex with 4.2 g Vulcan XC-72R (Cabot) carbon powder. The slurry was sonicated for 90 seconds at a power of about 200 watts, using a stir-bar to agitate the slurry during sonication. After sonication, 0.5 ml of Teflon-30 (Dupont) was added. The slurry was then sprayed onto the previously coated carbon paper with an air  
10 brush using multiple passes. Once the carbon paper had been wetted with the slurry, it was placed on a hot plate to evaporate the water and surfactant. The spraying/drying process was then repeated until a final (dried) added weight of 0.5 mg/cm<sup>2</sup> had been achieved. The total weight of the spray-on layers was 1.5 mg/cm<sup>2</sup>.

15

#### **MEDA Fabrication and Testing**

The respective diffusion layers were affixed to a commercially available membrane electrode assembly, such as that which may be secured from the W.L. Gore Company under the trade designation Primea Series 6000. This was done  
20 by placing the assembly in a hot press. The 60 cm<sup>2</sup> MEDA was hot pressed once for 4 minutes at 150 ° C at a pressure of 32 tons, and then re-pressed for an additional minute at 150 ° C at a pressure of 37 tons. The process was repeated to fabricate four MEDAs.

#### **25 Results**

A PEM fuel cell module 100 was fabricated using the four MEDAs. The fuel cell module 100 was configured as shown in Figures 10, 11, and 14, except

that the ceramic plate 205 was deleted, and the pressure transfer assembly 203 directly contacted the cathode current collector 192. The fuel cell module 100 was tested by inserting it into a test stand similar to that illustrated in Figure 5, and using a small fan to pass approximately 12 cubic feet per minute of air  
5 through the fuel cell module. The hydrogen feed pressure was set to about 8 psi. At 2.004 volts (approximately 0.5 volts per MEDA), a current of 24.0 amperes was measured using a calibrated DC current transducer, which yielded a current density of 400 mA/ cm<sup>2</sup> and a PEM fuel cell module power of 48.096 watts.

10 The main body 151 of the membrane electrode diffusion assembly 150, as earlier discussed, comprises an electrolyte membrane having substantially linear crosslinked polymeric chains incorporating sulfonic acid groups. In particular, the crosslinked polymeric chains are formed from monomeric units which are selected from the group consisting essentially of poly (ethylene glycol) methacrylate, poly  
15 (propylene glycol) methacrylate, poly (ethylene glycol) ethyl ether methacrylate, and poly (propylene glycol) methyl ether methacrylate, hydroxypropyl methacrylate, 2-hydroxyethyl methacrylate, the acrylate analogs, and 4-hydroxybutyl acrylate. Linear copolymers composed of similar monomeric units, but synthesized without crosslinking agents will be described below.

20 Still further, the sulfonic acid groups are selected from the group consisting essentially of 3-alkoxy-2-hydroxy-1-propanesulfonic acid, 4-styrenesulfonic acid, vinylsulfonic acid, 3-sulfopropyl methacrylate, 3-sulfopropylacrylate and fluorinated derivatives thereof. Additionally, the crosslinking agent utilized to crosslink the copolymers is selected from the group consisting essentially of  
25 ethylene glycol divinyl ether, diethylene glycol divinyl ether, triethylene glycol divinyl ether, ethylene glycol dimethacrylate, diethylene glycol dimethacrylate,

triethylene glycol dimethacrylate, glycerol dimethacrylate, diallyloxyacetic acid, and allylmethacrylate.

In the preferred form of this invention, the membrane electrode diffusion assembly 150 comprises:

5       about 35% to about 50% by molar concentration of a methacrylate monomer;

          about 30% to about 50% by molar concentration of an acrylate monomer;

          about 25% to about 45% by molar concentration of a sulfonic acid; and

          about 5% to about 20% by molar concentration of a compatible  
10 crosslinking agent.

In the preferred form of the invention as described above, the electrolyte membrane, or main body 151, which is incorporated into the membrane electrode diffusion assembly 150, has a glass transition temperature of at least about 110 degrees C, and has a preferred thickness of about 0.2 millimeter. Additionally,  
15 this electrolyte membrane 151 must be substantially stable in the presence of water, and operational at temperatures of less than about 80 degrees C. The electrolyte membrane 151, as noted above, may further comprise a compatible plasticizer which is selected from the group consisting essentially of phthalate esters. In still another form of the invention, the electrolyte membrane 151  
20 includes a porous supporting matrix which is made integral with the electrolyte membrane 151, and which provides mechanical strength to same. In this regard, the porous supporting matrix does not reactively produce hydrogen ions and is dielectric. Further, the porous supporting matrix is substantially inert and has a porosity of about 30% to about 80% and has a given proton conductivity  
25 which is proportional to the porosity of the supporting matrix. An acceptable porous supporting matrix may be selected from the group consisting essentially of grafted hydrophilic polyethylenes.

In its most preferred form, the electrolyte membrane 151 of the present invention comprises at least about 10% to about 50% by molar concentration of a copolymer which has monomeric units which are selected from the group consisting essentially of poly (ethylene glycol) methacrylate, poly (propylene glycol) methacrylate, poly (ethylene glycol) ethyl ether methacrylate, poly (propylene glycol) methyl ether methacrylate, hydroxypropyl methacrylate, 2-hydroxyethyl methacrylate, acrylate analogs and 4-hydroxybutyl acrylate;

at least about 25% to about 45% by molar concentration of an acid selected from the group consisting essentially of 3-alkoxy-2-hydroxy-1-propanesulfonic acid, 4-styrenesulfonic acid, vinylsulfonic acid, 3-sulfopropyl methacrylate, 3-sulfopropylacrylate and fluorinated derivatives thereof;

at least about 5% to about 20% by molar concentration of a crosslinking agent selected from the group consisting essentially of ethylene glycol divinyl ether, diethylene glycol divinyl ether, triethylene glycol divinyl ether, ethylene glycol dimethacrylate, diethylene glycol dimethacrylate, triethylene glycol dimethacrylate, glycerol dimethacrylate, diallyloxyacetic acid, and allylmethacrylate;

a compatible plasticizer; and

a support matrix having a given minimum porosity, and which is dielectric.

As discussed above, one example of a suitable electrolyte membrane 151 may be secured from the W. L. Gore Company under the trade designation Primea Series 6000 MEA.

Representative examples which concern the synthesis of the electrolyte membrane 151 are set forth below.

25

#### EXAMPLE 1

10.56 mL of a 15.78% w/v aqueous solution (8 mmol) of 3-sulfopropyl methacrylate was first concentrated so as to yield a final reaction mixture with



## 31

a water content of 16.3% v/v. Poly(propylene glycol) methacrylate (2.9600 g, 8 mmol), hydroxypropyl methacrylate (0.14422 g, 1 mmol), and glycerol dimethacrylate (0.4565 g, 2 mmol) were added to, and well mixed with the concentrated acid solution. The mixture was cooled to 4 degrees C, and then  
5 cold ethylene glycol divinyl ether (0.2283 g, 2 mmol), and ammonium persulfate (0.5052 g, 2.2 mmol) dissolved in 0.72 mL of water were added. After thorough mixing, the reaction mixture was de-aerated and applied onto grafted polyethylene (E15012) that was previously rendered hydrophilic. Photochemical polymerization was achieved under UV light for 10 minutes.

10

## EXAMPLE 2

A 15.78% w/v aqueous solution of 3-sulfopropyl methacrylate (7.92 mL, 6 mmol) was concentrated so as to obtain a final reaction mixture with 17.7% v/v water, and poly (propylene glycol) meth-acrylate (5.1800g, 14 mmol) was then  
15 added and well mixed. Benzoyl peroxide (0.4844g, 2 mmol) and 1,1-azobis(1-cyclohexanecarbonitrile) (0.4884g, 2 mmol) were dissolved in acetone (4 mL) and added. The reaction mixture was then de-aerated under vacuum and substantially all of the acetone was removed. Thermal polymerization was effected at 71-74 degrees C. for 90 minutes. After cooling to room temperature overnight, the  
20 product crystallized into bundles of needle-shaped crystals. Similar linear polymers were also synthesized by using hydroxypropyl methacrylate (14 mmol) and poly(ethylene glycol) methacrylate (14 mmol), in place of the poly (propylene glycol) methacrylate.

25

## EXAMPLE 3

A 35% aqueous solution of 3-allyloxy-2-hydroxy-1-propanesulfonic acid (21.60 mL, 40 mmol) was concentrated so as to yield a final reaction mixture

containing 120.9% v/v water. Poly(propylene glycol) methacrylate (11.1000 g, 30 mmol), hydroxypropyl methacrylate (2.8834g, 20 mmol), and diethylene glycol dimethacrylate (2.4227 g, 10 mmol) were added, and well mixed with the acid. The initiator ammonium persulfate (1.1410 g, 5 mmol) was dissolved in the  
5 proper amount of water and added. After thorough mixing, the reaction mixture was de-aerated, and either thermally polymerized in a mold at 75 degrees C. for 90 minutes or photochemically polymerized under UV light for 10 minutes using grafted and hydrophilized polyethylene as a support material. Poly(ethylene glycol) methacrylate was also used as a substitute for poly(propylene glycol)  
10 methacrylate, and the crosslinked mixture consisting of glycerol dimethacrylate (or diallyloxyacetic acid) and ethylene glycol divinyl ether was also used as a substitute for diethylene glycol dimethacrylate.

Each electrolyte membrane synthesized from the examples, above, were tested and were found to yield the performance characteristics as earlier  
15 discussed.

As seen in Figures 12-19 and 28, the proton exchange membrane fuel cell power system 10 of the present invention further includes a pair of current collectors 190 which are received in each of the respective cavities 121 through 124, respectively. The current collectors for identification have been given the  
20 numerals 191 and 192, respectively. The current collectors 190 are individually disposed in juxtaposed ohmic electrical contact with the opposite anode and cathode sides 153 and 154 of each membrane electrode diffusion assembly 150. As best seen in Figure 28, each current collector 190 has a main body 193 which has a plurality of apertures or open areas formed therein 194. In this  
25 regard, the main body has a given surface area of which, at least about 70% is open area. A conductive member 195 extends outwardly from the main body and is operable to extend through one of the openings or gaps 136 which are

formed in the hydrogen distribution frame 110. Such is seen in Figure 11. Each conductive member 195 is received between and thus electrically coupled within one of the 8 pairs of conductive contacts 51 which are mounted on the rear wall 41 of the subrack 30. This is illustrated most clearly by reference to  
5 Figures 3 and 4.

As a general matter, the current collectors 190 comprise a base substrate forming a main body 193, and wherein a coating(s) or layer(s) is applied to same and which is effective in maintaining electrical contact with the adjacent membrane electrode diffusion assembly 150. The main body 193 includes four  
10 discrete components. The first component is an electrically conductive substrate which may be capable of surface passivation if exposed to oxygen. Suitable materials which may be used in this discrete component of the main body 193 include current carrying substrates consisting essentially of 3XX Series chromium containing stainless steel or equivalent substitutes. These substrates have a bulk  
15 conductivity of about 2.4 IACS, and an overall thickness of about 0.7 to about 3mm. Additionally, copper or nickel substrates having a bulk conductivity of greater than about 24% IACS, and a thickness of about 0.20 to about 1.3 mm. may be used with equal success.

The second component, which may be utilized in forming the main body  
20 193 comprises a protection layer formed in covering relation over the conductive substrate, and which will passivate if inadvertently exposed to oxygen. Suitable materials for this second component include a foil cladding of 3XX Series chromium-containing stainless steel which has a bulk conductivity of about 2.4% IACS, and a thickness of about 0.02 to about 0.15 mm; or a coating or alloy  
25 combination consisting essentially of column IVB metal(s) such as tantalum and niobium which form a highly passivated pentoxide if exposed inadvertently to air.

This coating or alloy combination has a thickness of about 0.2 to about 2 microns.

The third component forming the main body 193 comprises an electrically conductive contact layer which is galvanically cathodic, and oxygen stable. Suitable materials which may be utilized in the contact layer include coatings formed from elements classified in column IVB and which are capable of forming nitrides. Examples of these materials include titanium or zirconium nitride, or an electrically conductive metal oxide such as indium-tin oxide (ITO). An equivalent substitute material includes platinum group metals such as palladium, platinum, rhodium, ruthenium, iridium and osmium. This third component has a thickness of about 0.2 to about 2 microns.

The fourth component forming the main body 193 comprises an electrolyte/oxygen exclusion layer. A suitable material for this function includes a graphite-filled electrically conductive adhesive. Such may be synthesized from a two-part epoxy or a silicone rubber.

Many combinations of the four components may be fabricated to produce a suitable main body 193. Each main body 193 will have an electrically conductive substrate. The assorted combinations of the other three components which are used therewith are not specifically set forth below, it being understood that not less than one of the remaining three components, and not more than all three remaining components must be brought together to form a suitable main body 193. In the preferred embodiment, the inventors have discovered that a main body 193 which is formed from an electrically conductive substrate, such as nickel or copper; a foil cladding comprising 3XX series chromium-containing stainless steel; and a coating formed from column IVB electrically conductive materials which can form nitrides operates with good results.

Referring now to Figures 12-19 and 22-25, respectively, the proton exchange membrane fuel cell power system 10 of the present invention further includes individual force application assemblies 200 for applying a given force to each of the pair of current collectors 190, and the membrane electrode diffusion assembly 150 which is sandwiched therebetween. In this regard, the individual force application assemblies are best illustrated by reference to Figures 13, 15, 17 and 19, respectively. In the first form of the force application assembly, which is shown in Figure 12 and 22, the force application assembly comprises a cathode cover 201 which partially occludes the respective cavities of the hydrogen distribution frame 110. As seen in the drawings, the respective cathode covers 201 individually releasably cooperate with each other and with the hydrogen distribution frame 110. A biasing assembly which is designated by the numeral 202, and shown herein as a plurality of metal wave springs cooperates with the cathode cover and is operable to impart force to an adjacent pressure transfer assembly 203 by means of a pressure distribution assembly 204. Referring now to Figures 14, 15, and 23, and in a second form of the invention, the pressure transfer assembly 203 transfers the force imparted to it by the cathode covers 201 to an adjoining pressure plate 205. In this form of the invention, the pressure distribution assembly is eliminated.

In a third form of the invention as seen in Figures 16 17, and 24, the force application assembly 202 comprises a cathode cover 201, a plurality of wave springs 202; and a corrugated pressure plate 232. In this form of the invention, the pressure transfer assembly 203 is eliminated from the assembly 200. In yet still another fourth form of the invention as seen in Figure 18, 19, and 25, the force application assembly 200 comprises a cathode cover 201; wave springs 202, and a pressure transfer assembly 203. In this form of the invention, the pressure plate 205 (of either design) and pressure distribution assembly 204 are

absent from the combination. In all the forms of the invention described above, a force of at least about 175 pounds per square inch is realized between the membrane electrode diffusion assembly 150 and the associated pair of current collectors 190.

5 Referring now to Figure 11, each cathode cover 201 has a main body 210 which is fabricated from a substrate which has a flexural modulus of at least about 1 million pounds per square inch. This is in contrast to the hydrogen distribution frame 110 which is fabricated from a substrate having a flexural modulus of less than about 500,00 pounds per square inch, and a compressive  
10 strength of less than 20,000 pounds per square inch. The main body 210 has an exterior facing surface 211, and an opposite interior facing surface 212 (Figure 13). Further, the main body has a peripheral edge 213 which has a plurality of apertures 214 formed therein. Each cathode cover nests, or otherwise matingly interfits with one of the respective cavities 121 through 124,  
15 respectively, which are defined by the hydrogen distribution frame 110. When appropriately nested, the individual apertures 214 are substantially coaxially aligned with the apertures 125 which are formed in the main body 111 of the hydrogen distribution frame 110. This coaxial alignment permits fasteners 215 to be received therethrough. When tightened, the opposing cathode covers exert a  
20 force, by means of the intermediate assemblies, described above, on the membrane electrode diffusion assembly 150 which is effective to establish good electrical contact between the respective current collectors 190 and the adjacent membrane electrode diffusion assembly 150. Still further, the main body 210 defines in part a third passageway 216. The third passageway 216 as seen in  
25 Figures 9 and 11, provides a convenient means by which the cathode air flow which is delivered by the exhaust end 73 of the air plenum 71, can be delivered to the cathode side 154 of the membrane electrode diffusion assembly 150. In

this regard, the air passageway has a first, or intake end 217 and a second, or exhaust end 218. As seen in Figure 9, the exhaust end of each third passageway 216 is located near one of the opposite ends 112 and 113 of the hydrogen distribution frame 110. As illustrated in Figure 6, the air which has  
5 exited through the exhaust end 218 passes through the apertures 42 and 43 formed in the top and bottom portions 35 and 40 of the subrack 30. As such, the air passes into the air plenum 71 and may be recycled by means of the air mixing valve 80 as was earlier described. As best illustrated by reference to Figures 13 and 22, the interior surface 212 of the cathode cover defines a cavity  
10 219 of given dimensions. The interior surface further defines a plurality of channels 220. The channels 220 are operable to matingly receive the individual wave springs which constitute the biasing assembly 202.

Referring now to Figure 29, the pressure transfer assembly 203 has an elongated main body 221 which comprises a central backbone 222. Additionally,  
15 a plurality of legs or members 223 extend or depend from the central backbone 222 and are operable to forcibly engage the pressure plate 205 in one form of the invention (Figures 14 and 23). Still further, the main body 220 has a first surface 224 and an opposite second surface 225. A channel 226 is formed in the first surface and matingly interfits or receives one of the metal wave springs  
20 constituting the biasing assembly 202 (Figure 25). In an alternative form of the invention, the pressure plate 205 is eliminated, and a pressure distribution member 204 is positioned between the biasing assembly 203 and the first surface 224 of the pressure transfer assembly (Figures 12 and 22). In this form of the invention, the pressure transfer assembly 204 is fabricated from a resilient  
25 substrate such that the individual legs or members will deform under pressure to an amount equal to about .001 to .004 inches.

As noted above, one form of the invention 10 may include a pressure plate 205 (Figures 14 and 15). In this regard the pressure plate 205, as illustrated, is a ceramic plate or an equivalent substitute having a main body 230. The ceramic plate, as shown in Figure 15, has a plurality of apertures 231  
5 formed therein which allows air to pass therethrough and which has traveled through the third passageway 216 which is formed, in part, in the main body 210 of the cathode cover 201. The main body 230 of the pressure plate 205 is substantially planar to less than about .002 inches. An alternative form of the pressure plate is shown in Figures 16 and 17 and is designated by the numeral  
10 232. This second form of the pressure plate is thicker than the pressure plate 205 which is shown in Figure 15. Referring now to Figures 20 and 21, the pressure plate 232 defines a given open area therebetween a plurality substantially equally spaced corrugations or undulations 233 which are formed in its surface. These corrugations or undulations define specific channels 234  
15 therebetween through which air can move. When the second form 232 of the pressure plate 205 is employed, the pressure transfer assembly 203 may be eliminated from the assembly as was earlier discussed. The channels, or open area 234 defined by the pressure plate 205, whether it be in the first form of the pressure plate as shown in Figure 15, or that shown in Figure 20, defines,  
20 in part, the third passageway 216 which allows air to pass through the cathode cover 201 to the cathode side 154 of the membrane electrode diffusion assembly 150. Such is best illustrated by reference to Figure 11. As earlier discussed, and as seen in Figures 12 and 13, one form of the invention 10 utilizes a pressure distribution assembly 204. When employed, the pressure plate 205 is  
25 eliminated and the pressure distribution assembly 204 is positioned between the wave springs which constitute the biasing assembly 202, and the pressure transfer assembly 203 which were described earlier. In this regard, the pressure



distribution assembly comprises a first substantially noncompressible and flexible substrate 240 (Figure 22). The first non-compressible substrate has a first surface 241 and an opposite second surface 242. The first surface 241 is in contact with the biasing assembly 202. Mounted upon the opposite, second surface 242 is a compressible substrate 243. The compressible substrate has an outwardly facing surface 244 which is in contact with the first surface 224 of the pressure transfer assembly 203. In operation, as the respective cathode covers and associated biasing assemblies 202 exert force, a certain amount of deflection or bending in the cathode covers may occur. This is shown in the drawings at Figure 22. When this event happens, the first surface of the pressure transfer assembly presses against the compressible surface 243 thereby maintaining a substantially constant pressure across the entire surface of the adjacent current collector 190. The proton exchange membrane fuel cell power system 10 further includes a digital programmable control assembly 250, as seen in the schematic view of Figure 30. The digital programmable control assembly 250 is electrically coupled with each of the discrete PEM fuel cell modules 100 such that they can be monitored with respect to the electrical performance of same. This digital programmable control assembly 250 is further electrically coupled with the air distribution assembly 70. Still further, the digital programmable control assembly 250 is electrically coupled with the fuel distribution assembly which comprises the source of hydrogen 60, accompanying valve assembly 61 and associated first conduit 54 which delivers the hydrogen by means of one of the valves 52 to each of the discrete PEM fuel cell modules 100.

Still further, and referring to Figure 31, the PEM fuel cell power system 10 of the present invention includes a heat exchanger 260 which is operably coupled with the air distribution assembly 70 which delivers air to the individual discrete PEM fuel cell modules 100. The heat exchanger 260 captures useful

thermal energy emitted by the discrete PEM fuel cell modules 100. Additionally, the power system 10 includes a power conditioning assembly 270 (Figure 1) comprising an inverter which is electrically coupled with the direct current bus 50 and which receives the direct current electrical energy produced by the individual discrete PEM fuel cell modules 100 and which converts same into suitable alternating current.

### OPERATION

The operation of the described embodiments of the present invention are believed to be readily apparent and are briefly summarized at this point.

In its broadest aspect, the present invention comprises a proton exchange membrane fuel cell power system 10 having a plurality of discrete proton exchange membrane fuel cell modules 100 which are self-humidifying and which individually produce a given amount of heat energy. Further, each of the discrete proton exchange membrane fuel cell modules 100 have a cathode air flow, and a preponderance of the heat energy produced by each of PEM fuel cell modules 100 is removed from same by the cathode air flow.

Another aspect of the present invention relates to a proton exchange membrane fuel cell power system 10 for producing electrical power and which comprises a plurality of discrete fuel cell modules 100, each having at least two membrane electrode diffusion assemblies 150. Each of the membrane electrode diffusion assemblies 150 have opposite anode 153, and cathode sides 154. Additionally, this PEM fuel cell power system 10 includes a pair of current collectors 190 each disposed in juxtaposed ohmic electrical contact with the opposite anode 153 and cathode sides 154 of each of the membrane electrode diffusion assemblies 150. Further, individual force application assemblies 200 for applying a given force to each of the current collectors and the individual

membrane electrode diffusion assemblies are provided. The individual force application assemblies, as earlier noted, may be in several forms. Commonly each form of the force application assemblies has a cathode cover 201, and a biasing assembly 202. However, in one form of the invention, a pressure plate 205 may  
5 be utilized, and comprises a ceramic plate having a plurality of apertures formed therein. As seen in Figure 14, a pressure transfer assembly 205 is provided and is effective to transmit force, by way of the pressure plate, to the underlying membrane electrode diffusion assembly 150. In an alternative form (Figure 16), a second pressure plate 232 may be employed. When used, the pressure transfer  
10 assembly 203 may be eliminated from the construction of the PEM fuel cell module 100. In still another form of the force application assembly 200 (Figure 12), the pressure plate 205 is eliminated and the pressure distribution assembly 204 is utilized to ensure that substantially equal force is applied across the surface area of the adjacent current collector 190.

15 As presently disclosed, the PEM fuel cell power system 10 and more particularly, the discrete PEM fuel cell modules 100 have an electrical efficiency of at least 40% and are self-humidifying, that is, no additional external humidification must be provided to the hydrogen fuel 60, or air which is supplied to same. Still further, the membrane electrode diffusion assemblies 150  
20 which are utilized in the present invention have an active area which has a given surface area. It has been determined that the discrete PEM fuel cell modules 100 produce a current density of at least about 350 m.A. per square centimeter of active area at a nominal cell voltage of at least about 0.5 volts D.C. Additionally, the discrete fuel cell modules 100 each have an electrical  
25 output of at least about 10.5 watts.

The individual proton exchange membrane fuel cell modules 100 are mounted within an enclosure 11 which includes a subrack 30 for supporting same.

The enclosure 11 which is utilized with the present proton exchange membrane fuel cell modules 100 further comprises a fuel distribution assembly 52, 54 and 60, for delivering hydrogen to the individual discrete PEM fuel cell modules 100. An air distribution assembly 70 for delivering air to the individual discrete PEM fuel cell modules 100 is provided, and a direct current output bus 50, and a power conditioning assembly 270 for receiving and inverting the electrical power produced by each of the discrete PEM fuel cell modules 100 are also received in the enclosure 11. As earlier discussed, each of the subracks 30 are mounted in the cavity 25 which is defined by the enclosure 11. The subracks 30 have forward and rearward edges 33, and 34 and top and bottom portions 35 and 40, respectively. Each of the discrete PEM fuel cell modules 100 are operably coupled with the fuel distribution assembly, direct current output bus 50 and power conditioning assembly 270 in the vicinity of the rearward edge 34 of each of the subracks 30 as seen most clearly in Figures 3, 4 and 6. Further, the discrete PEM fuel cell modules 100 are coupled in fluid flowing relation with the air distribution assembly 70 at the top and bottom portions 35 and 40 of each of the subracks 30 and with the air plenum 70 at the exhaust end 73 thereof.

Referring to Figure 6, the air distribution assembly 70 which is utilized in the present device includes a plenum 71 which is made integral with each of the subracks 30. The plenum has an exhaust end 73 which delivers air to each of the PEM fuel cell modules 100 supported on the subrack 30, and an intake end 72 which receives both air which has passed through each of the PEM fuel cell modules 100 and air which comes from outside the respective PEM fuel cell modules 100. Further, the air distribution assembly 70 includes an air movement assembly 74 in the form of a fan 75 which is operably coupled to the plenum 71 and which moves the air in a given direction along the plenum 71 to the

individual PEM fuel cell modules 100. An air mixing valve 80 is borne by the plenum 71, and controls the mixture of air which is recirculated back to the respective PEM fuel cell modules 100. As described earlier in greater detail, the individual discrete PEM fuel cell modules 100 include a hydrogen distribution  
5 frame 110 defining discrete cavities 120, and wherein the respective membrane electrode diffusion assemblies 150 are individually sealably mounted in each of the cavities 120. In the preferred form of the invention, the hydrogen distribution frame 110 is oriented between the individual membrane electrode diffusion assemblies 150. As best seen in Figure 10, the hydrogen distribution  
10 frame 110 comprises multiple pairs of discretely opposed cavities 121-124.

The hydrogen distribution frame 110 permits the delivery of hydrogen gas to each of the cavities 121-124. In this regard, the hydrogen distribution frame 110 defines a first passageway 131 which permits the delivery of hydrogen gas to each of the cavities 121-124 which are defined by the hydrogen distribution  
15 frame 110 and to the anode side 153 of the membrane electrode diffusion assembly 150. Still further, the hydrogen distribution frame 110 includes a second passageway 132 which facilitates the removal of impurities, water, and unreacted hydrogen from each of the cavities 121-124. As noted earlier, each of the cathode covers 201 and the respective force application assemblies 200  
20 define a third passageway 216 which permits delivery of air to each of the cavities 121-124, and to the cathode side 154 of each of the respective membrane electrode diffusion assemblies 150. Hydrogen gas is supplied by means of the first passageway 131 to each of the cavities 121-124 of the hydrogen distribution frame 110 at a pressure of about 1 PSIG to about 10 PSIG; and  
25 air is supplied at above ambient pressure by the air distribution assembly 70.

Also as discussed above, the source of hydrogen 60 is illustrated herein as a pressurized container of same which is received in the enclosure 11 (Figure

1). However, it is anticipated that other means will be employed for supplying a suitable quantity of hydrogen to the hydrogen distribution assembly 110. In this regard, a chemical or fuel reformer could be utilized and enclosed within or outside of the enclosure 11 and which would, by chemical reaction, produce  
5 a suitable quantity of hydrogen. The chemical reformer would be coupled with a supply of hydrogen rich fluid such as natural gas, ammonia, or similar fluids. The chemical reformer would then, by means of a chemical reaction, strip away the hydrogen component of the hydrogen rich fluid for delivery to the hydrogen distribution assembly. The remaining reformer by-products would then be  
10 exhausted to ambient (assuming these by-products did not produce a health, environmental or other hazard), or would be captured for appropriate disposal, or recycling.

The membrane electrode diffusion assembly 150 which is employed with the power system 10 of the present invention includes, as a general matter, a  
15 solid proton conducting electrolyte membrane 151 which has opposite anode and cathode sides 153 and 154; individual catalytic anode and cathode electrodes 161 and 162 which are disposed in ionic contact with the respective anode and cathode sides 153 and 154 of the electrolyte membrane 151; and a diffusion layer 170 borne on each of the anode and cathode electrodes 161 and 162 and  
20 which is electrically conductive and has a given porosity. With respect to the diffusion layer 170, in the preferred embodiment of the present invention 10, the diffusion layer 170 comprises a first diffusion layer 171 borne on the individual anode and cathode electrodes 161 and 162 and which is positioned in ohmic electrical contact therewith. The first diffusion layer 171 is electrically conductive  
25 and has a given pore size. Additionally, a second diffusion layer 172 is borne on the first layer 171 and is positioned in ohmic electrical contact with the underlying first diffusion layer 171. The second diffusion layer 172 is electrically

conductive and has a given pore size which is greater than the given pore size of the first diffusion layer 171.

In its broadest aspect the present invention 10 includes an electrolyte membrane 151 which comprises crosslinked polymeric chains incorporating sulfonic acid groups. More specifically, the electrolyte membrane 151 has at least a 20% molar concentration of sulfonic acid. The diffusion layer 170 which is employed with the membrane electrode diffusion assembly 150 of the present invention is deposited by means of a given method which was described earlier, and is not repeated herein.

In the present invention 10, the individual anode and cathode electrodes 161 and 162 in their broadest aspect, include particulate carbon; a catalyst; a binding resin; and a crosslinked copolymer incorporating sulfonic acid groups. In addition to the foregoing, the power system 10 further includes a pair of current collectors 190 which, in their broadest aspect, include a base substrate which is electrically conductive and is capable of surface passivation if exposed to oxygen; and a contact layer which is electrically conductive, galvanically cathodic and oxygen stable. Still further, the pair of current collectors 190 have a thickness of about 0.1 millimeters to about 1.3 millimeters and the contact layer has a thickness of about 0.2 microns to about 2 microns. In addition to the foregoing, the base substrate 190 has a given surface area of which at least 70% is open area.

The power system 10 includes a digital programmable control assembly 250 for monitoring the performance of the individual proton exchange membrane fuel cell modules 100, and other parameters of operation such as the flow rate of hydrogen 60 to the individual discrete PEM fuel cell modules 100, the heat output of each of the proton exchange membrane fuel cell modules 100, and the operation of the air distribution assembly 70 which mixes both outside air and

air which has previously passed through the individual proton exchange membrane fuel cell modules 100. The air mixing valve 80 is effective in controlling the temperature of the air which is delivered to each of the proton exchange membrane fuel cell modules 100, as well as the relative humidity. In this fashion, 5 the preponderance of heat energy generated by each of the PEM fuel cell modules 100 is effectively removed from same and either exhausted to ambient, or captured for other uses. The control assembly 250 is operable therefore to effectively optimize the operational conditions of the individually discrete PEM fuel cell modules 100 such that maximum current densities and efficiencies can 10 be realized.

Some of the most significant advantages of the present invention 10 is that it is modularized, simple, efficient in operation and easy to maintain. For example, in the event that a particular PEM fuel cell module 100 becomes inoperable, the disabled PEM fuel cell module 100 can be quickly removed, by 15 hand, from the subrack 30 and replaced with an operational module without interrupting the operation of the power system 10. This is a significant advancement in the art when considering the prior art teachings which show that a defective PEM fuel cell (manufactured as a stack) would require total disassembly of same while repairs were undertaken.

20 The present power system 10 has numerous other advantages over the prior art techniques and teachings, including the elimination of many of the balance-of-plant subassemblies typically utilized with such devices. Yet further, in view of the self-humidifying nature of the present proton exchange membrane fuel cell modules 100, other control measures have been simplified or otherwise 25 eliminated thereby increasing the performance capabilities of same while simultaneously reducing the costs to generate a given amount of electrical power.



In compliance with the statute, the invention has been described in language more or less specific as to structural or methodical features. It is to be understood, however, that the invention is not limited to specific features shown and described, since the means herein disclosed comprise preferred forms  
5 of putting the invention into effect. The invention is, therefore, claimed in any of its forms or modifications within the proper scope of the appended claims appropriately interpreted in accordance with the doctrine of equivalents.

CLAIMS

1. A proton exchange membrane fuel cell power system comprising:  
a plurality of discrete proton exchange membrane fuel cell modules which  
are self-humidifying and which produce a given amount of heat energy, and  
5 wherein each of the discrete fuel cell modules has a cathode air flow, and a  
preponderance of the heat energy is removed from the discrete proton exchange  
membrane fuel cell modules by the cathode air flow.

2. A power system as claimed in claim 1, wherein each discrete proton  
10 exchange membrane fuel cell module has at least two membrane electrode  
diffusion assemblies which have opposite anode and cathode sides, and wherein  
each PEM fuel cell module can be manipulated by hand.

3. A power system as claimed in claim 2, wherein each discrete proton  
15 exchange membrane fuel cell module has a pair of current collectors which are  
individually disposed in juxtaposed ohmic electrical contact with the opposite  
anode and cathode sides of each of the membrane electrode diffusion assemblies.

4. A power system as claimed in claim 3, wherein the discrete proton  
20 exchange membrane fuel cell modules have individual force application assemblies  
for applying a given force to each pair of current collectors and the individual  
membrane electrode diffusion assemblies associated therewith.

5. A power system as claimed in claim 3, wherein the individual  
25 current collectors comprise:

a base substrate which is electrically conductive and which has a given  
surface area of which at least about 70% is open area, and wherein the base

substrate is selected from the group consisting essentially of nickel, copper, and stainless steel; and

a coating applied over the base substrate and which is electrically conductive, galvanically cathodic and oxygen-stable.

5

6. A power system as claimed in claim 1, wherein the discrete proton exchange membrane fuel cell modules have an active area having a given surface area, and wherein each proton exchange membrane fuel cell module produces a current density of at least about 350 mA per square centimeter of active area  
10 at a nominal voltage of at least about 0.5 volts.

7. A power system as claimed in claim 1, wherein each discrete proton exchange membrane fuel cell module comprises:

a hydrogen distribution frame defining discrete, substantially opposed  
15 cavities and wherein the respective membrane electrode diffusion assemblies are individually sealably mounted in each of the cavities, and wherein the hydrogen distribution frame is oriented between the individual membrane electrode diffusion assemblies;

a cathode cover which releasably cooperates with the hydrogen distribution  
20 frame and which partially occludes each cavity;

a pair of current collectors received in each of the cavities of the hydrogen distribution frame;

a pressure transfer assembly cooperating with the cathode cover and which engages the current collector which is in ohmic electrical contact with the  
25 cathode side of the membrane electrode diffusion assembly; and

a biasing member oriented between the cathode cover and the pressure transfer assembly, and wherein the pressure transfer assembly applies a force such

that at least about 175 pounds per square inch is realized between the membrane electrode diffusion assembly and the associated pair of current collectors.

5           8.     A power system as claimed in claim 7, wherein the hydrogen distribution frame defines a first passageway which facilitates the delivery of a source of hydrogen to the cavity and to the anode side of the membrane electrode diffusion assembly, and a second passageway which facilitates the removal of unreacted hydrogen gas, water and impurities from the cavity; and  
10 wherein the cathode cover, and the pressure transfer assembly define a third passageway which facilitates the delivery of a source of ambient air to the cavity and to the cathode side of the membrane electrode diffusion assembly.

          9.     A power system as claimed in claim 2, wherein the membrane  
15 electrode diffusion assemblies each comprise:

          a solid proton conducting electrolyte membrane having opposite anode and cathode sides;

          individual catalytic anode and cathode electrodes disposed in ionic contact with the respective anode and cathode sides of the electrolyte membrane;

20           a first diffusion layer borne on the individual anode and cathode electrodes and which is positioned in ohmic electrical contact with each electrode, and wherein the first diffusion layer has a hydrophobic gradient; and

          a second diffusion layer on the first diffusion layer and which is positioned in ohmic electrical contact with the underlying first diffusion layer.

25

          10.    A power system as claimed in claim 9, wherein the solid proton conducting electrolyte membrane comprises:

about 35% to about 50% by molar concentration of a methacrylate monomer;

about 30% to about 50% by molar concentration of an acrylate monomer;

about 25% to about 45% by molar concentration of a sulfonic acid  
5 monomer; and

about 5% to about 20% by molar concentration of a compatible crosslinking agent.

11. A power system as claimed in claim 1, and further comprising:
- 10 a housing defining a cavity;
- a subrack mounted in the cavity and supporting the plurality of discrete proton exchange membrane fuel cell modules;
- a fuel distribution assembly received in the housing and coupled in fluid flowing relation relative to the subrack, the fuel distribution assembly delivering  
15 a source of hydrogen to each of the proton exchange membrane fuel cell modules, and wherein the discrete proton exchange membrane fuel cell modules are releasably coupled in fluid flowing relation relative to the fuel distribution system;
- a direct current bus mounted on the subrack, the individual proton  
20 exchange membrane fuel cell modules being releasably electrically coupled with the direct current bus;
- a power conditioning assembly electrically coupled with the direct current bus and which receives and inverts the electrical power produced by each of the discrete proton exchange membrane fuel cell modules;
- 25 an air distribution assembly mounted on the subrack and coupled in fluid flowing relation to each of the proton exchange membrane fuel cell modules, the air distribution assembly having an intake end which receives a source of air that

is to be delivered to each of the proton exchange membrane fuel cell modules, and an exhaust end which delivers the source of air to the discrete proton exchange membrane fuel cell modules, the source of air delivered to the proton exchange membrane fuel cell modules comprising the cathode air flow; and

5 a digital programmable controller electrically coupled with each of the proton exchange membrane fuel cell modules, fuel distribution assembly, power conditioning assembly, and the air distribution assembly.

12. A proton exchange membrane fuel cell power system for producing  
10 electrical power comprising:

a plurality of discrete fuel cell modules each having at least two membrane electrode diffusion assemblies, each of the membrane electrode diffusion assemblies having opposite anode and cathode sides;

a pair of current collectors each disposed in juxtaposed ohmic electrical  
15 contact with the opposite anode and cathode sides of each of the membrane electrode diffusion assemblies; and

individual force application assemblies for applying a given force to each pair of the current collectors and the individual membrane electrode diffusion assemblies.

20

13. A power system is claimed in claim 12, wherein the individually discrete fuel cell modules have an electrical efficiency of at least about 40%; and wherein the discrete fuel cell modules can be manipulated by hand.

25 14. A power system as claimed in claim 12, wherein the individually discrete fuel cell modules are self-humidifying, and wherein each discrete fuel cell module produces a given amount of heat and has a cathode air flow, and

wherein the cathode air flow removes a preponderance of the heat generated by each of the discrete fuel cell modules.

15           15.    A power system as claimed in claim 12, wherein each of the membrane electrode diffusion assemblies has an active area which has a given surface area, and wherein each of the discrete fuel cell modules produces a current density of at least about 350 mA per square centimeter of active area at a nominal cell voltage of about 0.5 volts D.C.

10           16.    A power system as claimed in claim 12, wherein each discrete fuel cell modules each has an electrical output of at least about 10.5 watts.

              17.    A power system as claimed in claim 12, and further comprising:  
              an enclosure defining a cavity; and  
15           a subrack mounted in the cavity and supporting the plurality of discrete fuel cell modules in a given orientation in the cavity.

              18.    A power system as claimed in claim 17, and wherein the enclosure further comprises:  
20           a heat exchanger for capturing thermal energy emitted by the discrete fuel cell modules.

              19.    A power system as claimed in claim 17, and wherein the enclosure further comprises:  
25           a digital programmable controller electrically coupled with each of the fuel cell modules.

20. A power system as claimed in claim 17, wherein the enclosure further comprises:

a fuel distribution assembly for delivering hydrogen to the individual discrete fuel cell modules;

5 an air distribution assembly for delivering air to the individual discrete fuel cell modules;

a direct current output bus; and

a power conditioning assembly for receiving and inverting the electrical power produced by each of the discrete fuel cell modules.

10

21. A power system as claimed in claim 20, wherein a plurality of subracks are mounted in the cavity, and wherein each of the subracks has a forward and rearward edge, and top and bottom portions, and wherein each of the fuel cell modules are operably coupled with the fuel distribution assembly,  
15 direct current output bus and the power conditioning assembly in the vicinity of the rearward edge of each of the subracks, and with the air distribution assembly at the top and bottom portions of each of the subracks.

22. A power system as claimed in claim 20, wherein the air distribution  
20 assembly further comprises:

a plenum constructed integrally with each of the subracks, the plenum having an exhaust end which delivers air to each of the fuel cell modules supported on the subrack, and an intake end which receives both air which has passed through each of the fuel cell modules, and air which comes from outside  
25 of the respective fuel cell modules;



an air movement assembly operably coupled to the plenum for moving the air in a given direction along the plenum to the individual fuel cell modules; and

an air mixing valve operably coupled to the plenum and controlling the amount of air which has passed through the respective fuel cells and which is recirculated back to each of the fuel cell modules.

23. A power system as claimed in claim 20, wherein the power conditioning assembly comprises:

an inverter for converting direct current voltage to alternating current voltage.

24. A power system as claimed in claim 12, wherein the discrete fuel cell modules comprise:

a hydrogen distribution frame defining discrete cavities and wherein the respective membrane electrode diffusion assemblies are individually sealably mounted in each of the cavities, and wherein the hydrogen distribution frame is oriented between the individual membrane electrode diffusion assemblies.

25. A power system as claimed in claim 24, wherein the hydrogen distribution frame comprises multiple pairs of discretely opposed cavities.

26. A power system as claimed in claim 24, wherein the force application assemblies each comprise:

a cathode cover which partially occludes the respective cavities of the hydrogen distribution frame, the respective cathode covers individually releasably cooperating with each other and with the hydrogen distribution frame;

a pressure transfer assembly oriented in juxtaposed relation relative to one of the current collectors;

a biasing member oriented between the respective cathode covers and the pressure transfer assembly, and wherein the pressure transfer assembly applies a  
5 force such that at least about 175 pounds per square inch is realized between the membrane electrode diffusion assembly and the associated pair of current collectors.

27. A power system as claimed in claim 26, wherein the force  
10 application assembly further comprises a pressure distribution assembly juxtaposed relative to the pressure transfer assembly, and wherein the pressure distribution assembly comprises:

a substantially non-compressible and flexible substrate; and

a semi-rigid substantially non-elastic and compressible substrate mounted on  
15 the non-compressible substrate, and wherein the compressible substrate is in contact with the pressure transfer assembly, and the non-compressible substrate is in contact with the biasing member.

28. A power system as claimed in claim 27, wherein the substantially  
20 non-compressible substrate comprises a thin metal plate.

29. A power system as claimed in claim 27, wherein the compressible substrate comprises rigid foam manufactured from a synthetic polymeric material.

25 30. A power system as claimed in claim 27, wherein the pressure distribution assembly facilitates the substantial uniform delivery of force from the adjoining cathode cover to the membrane electrode diffusion assembly.

31. A power system as claimed in claim 24, wherein the hydrogen distribution frame further defines a first passageway which permits the delivery of hydrogen gas to each of the cavities and to the anode side of the membrane electrode diffusion assembly, and a second passageway which facilitates the  
5 removal of impurities, water and unreacted hydrogen from each of the cavities, and wherein each of the cathode covers and the respective force application assemblies define a third passageway which permits delivery of air to each of the cavities and to the cathode side of each of the respective membrane electrode diffusion assemblies.

10

32. A power system as claimed in claim 31, wherein the pressure transfer assembly is juxtaposed relative to the current collector which is disposed in ohmic electrical contact with the cathode side of the membrane electrode distribution assembly, and wherein the pressure transfer assembly defines a given  
15 open area between the adjacent current collector and the adjoining cathode cover, and wherein the open area defines, in part, the third passageway, and wherein the biasing member distributes the force transmitted by the respective cathode covers through the pressure transfer assembly.

20 33. A power system as claimed in claim 31, wherein the hydrogen gas is supplied by means of the first passageway to each of the cavities at a pressure of about 1 P.S.I.G. to about 10 P.S.I.G., and wherein the air is supplied at a substantially ambient, fan forced pressure.

25 34. A power system as claimed in claim 26, wherein the cathode covers are fabricated from a substrate having a flexural modulus of at least about 1.00 million pounds per square inch, and wherein the hydrogen distribution frame is

fabricated from a substrate having a flexural modulus of less than about 500,000 pounds per square inch, and a compressive strength of less than about 20,000 pounds per square inch.

5           35.    A power system as claimed in claim 26, wherein the cathode cover defines a passageway which facilitates the delivery of a cathode air flow to each of the fuel cell modules, and wherein each fuel cell module produces heat, and the preponderance of the heat is removed from the fuel cell modules by the cathode air flow.

10

          36.    A power system as claimed in claim 26, wherein the biasing member comprises metal wave springs which matingly cooperate with the adjoining cathode cover, and wherein the pressure transfer assembly comprises a main body having a plurality of resilient legs which exert force on the pair of current  
15 collectors and the membrane electrode diffusion assembly, and wherein the individual legs have a spring deflection of about 0.001 to about 0.004 inches.

          37.    A power system as claimed in claim 12, wherein the membrane electrode diffusion assemblies each comprise:

20           a solid proton conducting electrolyte membrane which has opposite anode and cathode sides;

          individual catalytic anode and cathode electrodes disposed in ionic contact with the respective anode and cathode sides of the electrolyte membrane; and

          a diffusion layer borne on each of the anode and cathode electrodes and  
25 which is electrically conductive and has a given minimum porosity.

38. A power system as claimed in claim 37, wherein the diffusion layer further comprises:

a first diffusion layer borne on the individual anode and cathode electrodes and which is positioned in ohmic electrical contact with each electrode  
5 and which is electrically conductive and has a given pore size; and

a second diffusion layer borne on the first diffusion layer and which is positioned in ohmic electrical contact with the underlying first diffusion layer, and which further is electrically conductive and has a pore size which is greater than the given pore size of the first diffusion layer.

10

39. A power system as claimed in claim 37, wherein the electrolyte membrane has at least about a 20% molar concentration of a sulfonic acid monomer.

15 40. A power system as claimed in claim 37, wherein the electrolyte membrane comprises crosslinked polymeric chains incorporating sulfonic acid groups.

20 41. A power system as claimed in claim 40, wherein the crosslinked polymeric chains are formed from monomeric units which are selected from the group consisting essentially of:

poly (ethylene glycol) methacrylate, poly (propylene glycol) methacrylate, poly (ethylene glycol) ethyl ether methacrylate, and poly (propylene glycol) methyl ether methacrylate, hydroxypropyl methacrylate, 2-hydroxyethyl methacrylate, the  
25 acrylate analogs, and 4-hydroxybutyl acrylate.

42. A power system as claimed in claim 40, wherein the sulfonic acid monomers are selected from the group consisting essentially of:

3-alkoxy-2-hydroxy-1-propanesulfonic acid, 4-styrenesulfonic acid, vinylsulfonic acid, 3-sulfopropyl methacrylate, 3-sulfopropylacrylate and fluorinated derivatives  
5 thereof.

43. A power system as claimed in claim 40, wherein the crosslinking agent is selected from the group consisting essentially of:

ethylene glycol divinyl ether, diethylene glycol divinyl ether, triethylene  
10 glycol divinyl ether, ethylene glycol dimethacrylate, diethylene glycol dimethacrylate, triethylene glycol dimethacrylate, glycerol dimethacrylate, diallyloxyacetic acid; and allylmethacrylate.

44. A power system as claimed in claim 37, wherein the electrolyte  
15 membrane comprises crosslinked copolymeric chains having sulfonic acid groups, and wherein the crosslinked copolymeric chains comprise methacrylate and a crosslinking agent.

45. A power system as claimed in claim 44, wherein the sulfonic acid  
20 groups are selected from the group consisting essentially of 3-alkoxy-2-hydroxy-1-propane sulfonic acid, 4-styrenesulfonic acid, vinyl sulfonic acid; and 3-sulfopropyl methacrylate, 3-sulfopropylacrylate, and fluorinated derivatives thereof; and the crosslinking agent is selected from the group consisting essentially of ethylene glycol divinyl ether, diethylene glycol divinyl ether, triethylene glycol divinyl ether,  
25 ethylene glycol dimethacrylate, diethylene glycol dimethacrylate, triethylene glycol dimethacrylate, glycerol dimethacrylate, diallyloxyacetic acid, allylmethacrylate and mixtures thereof.

## 61

46. A power system as claimed in claim 37, wherein the electrolyte membrane comprises:

about 35% to about 50% by molar concentration of a methacrylate monomer;

5 about 30% to about 50% by molar concentration of an acrylate monomer;

about 25% to about 45% by molar concentration of a sulfonic acid monomer; and

about 5% to about 20% by molar concentration of a compatible crosslinking agent.

10

47. A power system as claimed in claim 37, wherein the glass transition temperature of the electrolyte membrane is at least about 110 degrees C., and wherein the electrolyte membrane has a thickness of less than about 1 millimeter, and is substantially stable in the presence of water, and operational at  
15 temperatures of less than about 80 degrees C.

48. A power system as claimed in claim 46, and further comprising a compatible plasticizer.

20 49. A power system as claimed in claim 37, wherein the electrolyte membrane further comprises:

a porous supporting matrix which is made integral with the electrolyte membrane.

25 50. A power system as claimed in claim 49, wherein the porous supporting matrix does not reactively produce hydrogen ions and is not electrically conductive.

## 62

51. A power system as claimed in claim 49, wherein the porous supporting matrix is substantially inert, and has a porosity of about 30% to about 80%.

5 52. A power system as claimed in claim 49, wherein the electrolyte membrane has a given proton conductivity which is proportional to the porosity of the supporting matrix.

53. A power system as claimed in claim 37, wherein the solid  
10 electrolyte membrane comprises:

- a polymethacrylate;
- an acrylate or methacrylate;
- a sulfonic acid;
- a crosslinking agent; and
- 15 a compatible plasticizer.

54. A power system as claimed in claim 53, wherein the polymethacrylate is selected from the group consisting essentially of:

- poly (ethylene glycol) methacrylate, poly (propylene glycol) methacrylate,
- 20 poly (ethylene glycol) ethyl ether methacrylate, and poly (propylene glycol) methyl ether methacrylate; and wherein the acrylate or methacrylate consists essentially of hydroxypropyl methacrylate, 2-hydroxyethyl methacrylate, the acrylate analogs, and 4-hydroxybutyl acrylate.

25 55. A power system as claimed in claim 53, wherein the polymethacrylate is about 20% to about 90% by weight.



## 63

56. A power system as claimed in claim 53, wherein the sulfonic acid is selected from the group consisting essentially of:

3-alkoxy-2-hydroxy-1-propanesulfonic acid, 4-styrenesulfonic acid, vinylsulfonic acid, 3-sulfopropyl methacrylate, 3-sulfopropylacrylate, and fluorinated derivatives  
5 thereof.

57. A power system as claimed in claim 56, wherein the sulfonic acid comprises about 25% to about 45% by molar concentration.

10 58. A power system as claimed in claim 53, wherein the crosslinking agent is selected from the group consisting essentially of:

ethylene glycol divinyl ether, diethylene glycol divinyl ether, triethylene glycol divinyl ether, ethylene glycol dimethacrylate, diethylene glycol dimethacrylate, triethylene glycol dimethacrylate, glycerol dimethacrylate, diallyloxyacetic acid,  
15 allylmethacrylate and mixtures thereof.

59. A power system as claimed in claim 58, wherein the crosslinking agent is about 5% to about 20% by molar concentration.

20 60. A power system as claimed in claim 37, wherein the solid proton conducting electrolyte membrane comprises:

at least about 10% to about 50% by molar concentration of a copolymer which has monomeric units which are selected from the group consisting essentially of poly (ethylene glycol) methacrylate, poly (propylene glycol) methacrylate, poly (ethylene glycol) ethyl ether methacrylate, poly (propylene glycol) methyl ether methacrylate, hydroxypropyl methacrylate, 2-hydroxyethyl methacrylate, acrylate analogs and 4-hydroxybutyl acrylate;

at least about 25% to about 45% by molar concentration of an acid selected from the group consisting essentially of 3-alkoxy-2-hydroxy-1-propanesulfonic acid, 4-styrenesulfonic acid, vinylsulfonic acid, 3-sulfopropyl methacrylate, 3-sulfopropylacrylate and fluorinated derivatives thereof;

5 at least about 5% to about 20% by molar concentration of a crosslinking agent selected from the group consisting essentially of ethylene glycol divinyl ether, diethylene glycol divinyl ether, triethylene glycol divinyl ether, ethylene glycol dimethacrylate, diethylene glycol dimethacrylate, triethylene glycol dimethacrylate, glycerol dimethacrylate, diallyloxyacetic acid, and allylmethacrylate;

10 a compatible plasticizer; and

a support matrix having a given minimum porosity, and which is not electrically conductive.

61. A power system as claimed in claim 12, wherein the membrane  
15 electrode diffusion assemblies each comprise:

a solid proton conducting electrolyte membrane which has opposite anode and cathode sides;

individual catalytic anode and cathode electrodes formed on the proton conducting electrolyte membrane and which are in ionic contact therewith; and

20 a non-catalytic electrically conductive diffusion layer affixed on the anode and cathode electrodes and which has a given porosity.

62. A power system as claimed in claim 61, wherein the non-catalytic electrically conductive diffusion layer has a first diffusion layer which is positioned  
25 in ohmic electrical contact with each of the electrodes; and a second diffusion layer positioned in ohmic electrical contact with the underlying first diffusion layer.

## 65

63. A power system as claimed in claim 62, wherein the non-catalytic electrically conductive diffusion layer is borne on a third diffusion layer.

64. A power system as claimed in claim 62, wherein the first diffusion  
5 layer comprises a coating of particulate carbon suspended in a binding resin; and the second diffusion layer comprises a porous hydrophobic carbon backing layer.

65. A power system as claimed in claim 64, wherein the binding resin is substantially hydrophobic and is selected from the group consisting essentially  
10 of fluorinated hydrocarbons; and wherein the first diffusion layer has about 20% to about 90%, by weight, of the particulate carbon.

66. A power system as claimed in claim 64, wherein the porous hydrophobic backing layer forming the second diffusion layer is selected from the  
15 group consisting essentially of carbon cloth, carbon paper, or carbon sponge which has been rendered hydrophobic.

67. A power system as claimed in claim 66, wherein the hydrophobic backing layer is coated with a liquid suspension comprising about 95% to about  
20 99% by weight of water; and about 1% to about 5% by weight of a compatible surfactant.

68. A power system as claimed in claim 62, wherein the first diffusion layer is a composite coating formed of successive layers of the first diffusion  
25 layer, each of the successive layers having a given hydrophobicity, and wherein the first diffusion layer has a hydrophobic gradient, and wherein the hydrophobic

gradient is established by adjusting the hydrophobicity of the successive layers forming the composite layer.

69. A power system as claimed in claim 68, wherein the successive  
5 layers closest to the second diffusion layer are the least hydrophobic of all of the successive layers.

70. A power system as claimed in claim 68, wherein the successive  
10 layers closest to the second diffusion layer are the most hydrophobic of all of the successive layers.

71. A power system as claimed in claim 61, wherein the diffusion layer has a variable porosity.

15 72. A power system as claimed in claim 61, wherein a thermoplastic binding agent is positioned between the anode and cathode electrodes and the overlying diffusion layer and is effective to bind the diffusion layer to the underlying anode and cathode electrode.

20 73. A power system as claimed in claim 72, wherein the thermoplastic binding agent is selected from the group consisting essentially of polyethylene or wax.

74. A power system as claimed in claim 61, wherein the individual  
25 anode and cathode electrodes include an electrolyte, and wherein the electrolyte and the solid proton conducting electrolyte membrane include a cross-linked copolymer incorporating sulfonic acid groups.

75. A power system as claimed in claim 61, wherein the individual anode and cathode electrodes comprise:

particulate carbon;

a catalyst; and

5 a cross-linked copolymer incorporating sulfonic acid groups.

76. A power system as claimed in claim 61, wherein the individual anode and cathode electrodes comprise:

a particulate carbon;

10 a catalyst;

a binding resin; and

a cross-linked copolymer incorporating sulfonic acid groups.

77. A power system as claimed in claim 61, wherein the individual  
15 anode and cathode electrodes are gas diffusing, and include an electrolyte, and wherein the electrolyte and the solid proton conducting membrane include a cross-linked copolymer having sulfonic acid groups.

78. A power system as claimed in claim 12, wherein each of the  
20 current collectors comprise:

a base substrate which is electrically conductive; and

an electrically conductive contact layer borne on the base substrate and which is galvanically cathodic and oxygen stable.

25 79. A power system as claimed in claim 78, and further comprising a protection layer which will passivate when exposed to oxygen; and an electrolyte exclusion layer.

80. A power system as claimed in claim 78, wherein the base substrate is selected from group consisting essentially of chromium-containing stainless steel, copper, and nickel; and the contact layer is selected from group comprising column IVB elements which form electrically conductive nitrides, and one or  
5 more coatings of palladium, platinum, rhodium, ruthenium, iridium, and osmium.

81. A power system as claimed in claim 79, wherein the protection layer is selected from the group consisting essentially of a foil cladding of chromium containing stainless steel and elements selected from column IVB of  
10 the periodic table and which form a highly passivated pentoxide when exposed to air.

82. A power system as claimed in claim 80, wherein the base substrate has a thickness of about 0.11 millimeters to about 3 millimeters; and wherein the  
15 contact layer has a thickness of about 0.2 to about 20 microns.

83. A power system as claimed in claim 78, wherein the base substrate has a given surface area of which at least about 70% is open area.

20 84. A proton exchange membrane fuel cell power system comprising:  
a plurality of discrete proton exchange membrane fuel cell modules each having a hydrogen distribution frame defining discrete, substantially opposed cavities;  
a membrane electrode diffusion assembly which has opposite anode and  
25 cathode sides and which is sealably mounted in a predetermined position in each of the cavities;

a pair of current collectors positioned in each of the cavities and individually oriented in juxtaposed ohmic electrical contact with the opposite anode and cathode sides of each of the membrane electrode diffusion assemblies;

a pressure transfer assembly positioned in each of the cavities and  
5 disposed in force transmitting relation relative to the membrane electrode diffusion assembly and the pair of current collectors; and

a cathode cover oriented in partially occluding relation relative to each of the cavities and matingly cooperating with the hydrogen distribution frame.

10 85. A power system as claimed in claim 84, and further comprising a biasing assembly oriented between the respective cathode covers and the pressure transfer assembly, and wherein the pressure transfer assembly applies a force of at least about 175 pounds per square inch which is realized between the membrane electrode diffusion assembly and the associated pair of current  
15 collectors.

86. A power system as claimed in claim 84, and further comprising a pressure distribution assembly which is positioned between the cathode cover and the pressure transfer assembly.

20

87. A power system as claimed in claim 84, wherein the hydrogen distribution frame further defines a first passageway which permits the delivery of hydrogen gas to each of the cavities and to the anode side of the membrane electrode diffusion assembly, and a second passageway which facilitates the  
25 removal of impurities, water and unreacted hydrogen from each of the cavities, and wherein each of the cathode covers and the respective pressure transfer assembly defines a third passageway which permits delivery of air to each of the

cavities and to the cathode side of each of the respective membrane electrode diffusion assemblies.

88. A power system as claimed in claim 84, wherein the membrane  
5 electrode diffusion assemblies comprise:

a solid proton conducting electrolyte membrane which has opposite anode and cathode sides;

individual catalytic anode and cathode electrodes disposed in ionic contact with the respective anode and cathode sides of the electrolyte membrane; and

10 a diffusion layer borne on each of the anode and cathode electrodes and which is electrically conductive and has a given minimum porosity.

89. A power system as claimed in claim 88, wherein the electrolyte membrane has at least about a 20% molar concentration of a sulfonic acid.

15

90. A power system as claimed in claim 88, wherein the electrolyte membrane comprises:

about 35% to about 50% by molar concentration of a methacrylate monomer;

20 about 30% to about 50% by molar concentration of an acrylate monomer;

about 25% to about 45% by molar concentration of a sulfonic acid monomer; and

about 5% to about 20% by molar concentration of a compatible crosslinking agent.

25

91. A power system as claimed in claim 84, wherein the individual current collectors comprise:



a base substrate having a bulk conductivity of at least about 13% IACS;  
and

a passivated oxide coating over the base substrate and which is inert and galvanically cathodic.

5

92. A power system as claimed in claim 91, wherein the base substrate has a given surface area of which at least 70% is open area.

93. A power system as claimed in claim 84, wherein the cathode covers  
10 are fabricated from a substrate having a flexural modulus of at least about 1.00 million pounds per square inch, and wherein the hydrogen distribution frame is fabricated from a substrate having a flexural modulus of less than about 500,000 pounds per square inch, and a compressive strength of less than about 20,000 pounds per square inch.

15

94. A power system as claimed in claim 84, and further comprising  
a subrack for supporting the plurality of discrete fuel cell modules;  
a plenum made integral with the subrack, the plenum having an exhaust  
end which delivers air to each of the fuel cell modules supported on the  
20 subrack, and an intake end which receives both air which has passed through each of the fuel cell modules, and air which comes from outside of the respective fuel cell modules;

an air movement assembly operably coupled to the plenum for moving the  
air in a given direction along the plenum to the individual fuel cell modules;  
25 and

an air mixing valve borne by the plenum and controlling the amount of air which has passed through the respective fuel cells and which is recirculated back to each of the fuel cell modules.

- 5           95.    A proton exchange membrane fuel cell power system comprising:
- a plurality of discrete fuel cell modules each having a hydrogen distribution frame defining discrete, substantially opposed cavities, the hydrogen distribution frame defining a first passageway which permits the simultaneous delivery of hydrogen gas to each of the cavities, and a second passageway which
- 10 facilitates the removal of impurities, water and unreacted hydrogen from each of the cavities;
- a membrane electrode diffusion assembly which has opposite anode and cathode sides and which is sealably mounted in a predetermined position in each of the cavities, the membrane electrode diffusion assembly having a solid proton
- 15 conducting electrolyte membrane which has opposite anode and cathode sides; individual catalytic anode and cathode electrodes disposed in ionic contact with the respective anode and cathode sides of the electrolyte membrane; and a diffusion layer borne on each of the anode and cathode electrodes and which is electrically conductive and has a given minimum pore size;
- 20           a pair of current collectors positioned in each of the cavities and individually oriented in juxtaposed ohmic electrical contact with the opposite anode and cathode sides of each of the membrane electrode diffusion assemblies, and wherein the current collectors have a surface coating which is inert and galvanically cathodic;
- 25           a pressure transfer assembly positioned in each of the cavities and disposed in force transmitting relation relative to the membrane electrode diffusion assembly and the pair of current collectors, and wherein the pressure

transfer assembly has a main body with a plurality of resilient members extending therefrom;

a cathode cover oriented in partially occluding relation relative to each of the cavities and matingly cooperating with the hydrogen distribution frame, and  
5 wherein the cathode covers and the respective pressure transfer assembly define a third passageway which permits delivery of air to each of the cavities and to the cathode side of the membrane electrode diffusion assembly; and

a biasing assembly oriented between the respective cathode covers and the pressure transfer assembly, and wherein a force of at least about 175 pounds per  
10 square inch is realized between the membrane electrode diffusion assembly and the associated pair of current collectors.

96. A power system as claimed in claim 95, and further comprising:

a subrack for supporting the plurality of discrete fuel cell modules;

15 a plenum made integral with the subrack, the plenum having an exhaust end which delivers air to each of the fuel cell modules supported on the subrack, and an intake end which receives both air which has passed through each of the fuel cell modules, and air which comes from outside of the respective fuel cell modules;

20 an air movement assembly operably coupled to the plenum for moving the air in a given direction along the plenum to the individual fuel cell modules; and

an air mixing valve borne by the plenum and controlling the amount of air which has passed through the respective fuel cells and which is recirculated  
25 back to each of the fuel cell modules.

97. A power system as claimed in claim 95, wherein the cathode covers are fabricated from a substrate having a flexural modulus of at least about 1.00 million pounds per square inch, and wherein the hydrogen distribution frame is fabricated from a substrate having a flexural modulus of less than about 500,000  
5 pounds per square inch, and a compressive strength of less than about 20,000 pounds per square inch.

98. A power system as claimed in claim 95, wherein the electrolyte membrane comprises:

10 at least about 10% to about 50% by molar concentration of a copolymer which has monomeric units which are selected from the group consisting essentially of poly (ethylene glycol) methacrylate, poly (propylene glycol) methacrylate, poly (ethylene glycol) ethyl ether methacrylate, poly (propylene glycol) methyl ether methacrylate, hydroxypropyl methacrylate, 2-hydroxyethyl  
15 methacrylate, acrylate analogs and 4-hydroxybutyl acrylate;

at least about 25% to about 45% by molar concentration of an acid selected from the group consisting essentially of 3-alkoxy-2-hydroxy-1-propanesulfonic acid, 4-styrenesulfonic acid, vinylsulfonic acid, 3-sulfopropyl methacrylate, 3-sulfopropylacrylate and fluorinated derivatives thereof;

20 at least about 5% to about 20% by molar concentration of a crosslinking agent selected from the group consisting essentially of ethylene glycol divinyl ether, diethylene glycol divinyl ether, triethylene glycol divinyl ether, ethylene glycol dimethacrylate, diethylene glycol dimethacrylate, triethylene glycol dimethacrylate, glycerol dimethacrylate, diallyloxyacetic acid, and allylmethacrylate;

25 a compatible plasticizer; and

a support matrix having a given minimum porosity, and which is not electrically conductive.

99. A power system as claimed in claim 95, wherein the solid proton conducting electrolyte membrane comprises:

a polymethacrylate;

an acrylate or methacrylate;

5 a sulfonic acid;

a crosslinking agent; and

a compatible plastizer.

100. A power system as claimed in claim 95, wherein the current  
10 collectors comprise:

a base substrate having a bulk conductivity of at least about 2.4% IACS;

and a contact layer over the base substrate and which is electrically conductive, galvanically cathodic, and oxygen stable, and wherein the contact layer consists essentially of substances having constituent elements from Groups IVB of the  
15 periodic table of elements, and wherein the contact layer is further characterized by its ability to form an electrically conductive nitride.

101. A power system as claimed in claim 95, wherein the discrete fuel cell modules are self-humidifying, and wherein each of the membrane electrode  
20 diffusion assemblies has an active area which has a given surface area, and wherein each of the discrete fuel cell modules produces a current density of at least about 350 mA per square centimeter of active area at a nominal cell voltage of about 0.5 volts D.C., and wherein the plurality of discrete fuel cell modules each have an electrical output of at least about 10.5 watts.

25

102. A power system housing, comprising:

an enclosure defining a cavity; and

a subrack mounted in the cavity and supporting a plurality of discrete proton exchange membrane fuel cell modules in a given orientation in the cavity.

103. A power system housing as claimed in claim 102, wherein the  
5 subrack has forward and rearward edges and top and bottom portions, and wherein the power system housing further comprises a hydrogen distribution assembly received in the enclosure and mounted in fluid flowing relation relative to each of the discrete proton exchange membrane fuel cell modules, the hydrogen distribution assembly releasably coupling to each of the discrete proton  
10 exchange membrane fuel cell modules in the vicinity of the rearward edge of the subrack.

104. A power system housing as claimed in claim 102, wherein the subrack has forward and rearward edges, and top and bottom portions, and  
15 wherein the power system further comprises an air distribution assembly which is received in the enclosure and coupled in fluid flowing relation relative to the top and bottom portions of the subrack.

105. A power system housing as claimed in claim 104, wherein the air  
20 distribution assembly further comprises:

a plenum made integral with each of the subracks, the plenum having an intake end which receives air from each of the discrete proton exchange membrane fuel cell modules supported on the subrack at the top and bottom portions thereof, and air which comes from outside of the respective proton  
25 exchange membrane fuel cell modules; and an exhaust end which delivers both air which has passed through each of the proton exchange membrane fuel cell

modules, and air which comes from outside of the respective proton exchange membrane fuel cell modules;

an air movement assembly operably coupled to the plenum for moving the air from the intake end to the exhaust end of the plenum; and

5 an air mixing valve operably coupled with the plenum and controlling the amount of air which has passed through the respective fuel cells and which is recirculated back to each of the fuel cell modules.

106. A power system housing as claimed in claim 105, wherein the  
10 discrete proton exchange membrane fuel cell modules produce thermal energy, and wherein the power system comprises a heat exchanger which is coupled in fluid flowing relation relative to the air distribution assembly, and which captures the thermal energy produced by each of the discrete fuel cell modules.

15 107. A power system housing as claimed in claim 105, wherein the air mixing valve is disposed in selectively adjustable fluid metering relation relative to the intake end of the plenum, and the air movement assembly is disposed intermediate the intake and exhaust ends of the plenum, and wherein the air mixing valve mixes both air which comes from outside of the respective discrete  
20 proton exchange membrane fuel cell modules and air which has passed through each of the discrete proton exchange membrane fuel cell modules.

108. A power system housing as claimed in claim 105, and further comprising:

25 temperature sensors for sensing the temperature of the air entering the discrete proton exchange membrane fuel cell modules, the outside air, and the

air which has passed through each of the discrete proton exchange membrane fuel cell modules;

an actuator disposed in force transmitting relation relative to the air mixing valve, the actuator, when energized, moving the air mixing valve along a  
5 given course of travel between a first position and a second position, and wherein movement of the air mixing valve along the course of travel facilitates the selective mixing of the outside air with the air which has previously passed through the respective proton exchange membrane fuel cell modules; and

a controller electrically coupled in sensing relation relative to the  
10 temperature sensors and the actuator, the controller selectively energizing the actuator to move the air mixing valve along the course of travel to control the temperature of the air delivered at the exhaust end of the plenum.

109. A power system housing as claimed in claim 108, wherein the air  
15 mixing valve, when located in the first position delivers outside air to the plenum, and in the second position, the air mixing valve delivers a variable mixture of both air which comes from outside of the respective discrete proton exchange membrane fuel cell modules and air which has passed through each of the respective discrete proton exchange membrane fuel cell modules.

20

110. A power system housing as claimed in claim 108, wherein the air movement assembly has a speed of operation which is variably adjustable, and wherein the controller is electrically coupled in controlling relation relative to the speed of operation of the air movement assembly.

25

111. A power system housing as claimed in claim 102, wherein each of the discrete proton exchange membrane fuel cell modules produces electrical



power, and wherein the power system housing further comprises a power conditioning assembly for receiving and inverting the electrical power produced by each of the discrete fuel cell modules.

5           112. A power system housing as claimed in claim 111, wherein the power conditioning assembly comprises:

          an inverter for converting direct current voltage to alternating current voltage.

10           113. A power system housing as claimed in claim 102, wherein the discrete proton exchange membrane fuel cell modules produce thermal energy, and wherein the power system housing comprises a heat exchanger for capturing the thermal energy emitted by the discrete fuel cell modules.

15           114. A power system housing as claimed in claim 102, and further comprising a digital programmable controller electrically coupled with each of the discrete proton exchange membrane fuel cell modules.

          115. A power system housing as claimed in claim 102, wherein the  
20 subrack has forward and rearward edges, and wherein the power system housing further comprises a direct current bus which is mounted in the vicinity of the rearward edge of the subrack, and the discrete proton exchange membrane fuel cell modules are releasably electrically coupled with the direct current bus.

25           116. A power system housing, comprising:  
          an enclosure defining a cavity;

a subrack mounted in the cavity, the subrack having forward and rearward edges, and top and bottom portions, the subrack supporting a plurality of discrete proton exchange membrane fuel cell modules in a given orientation in the cavity;

a hydrogen distribution assembly received in the cavity of the enclosure  
5 and mounted in fluid flowing relation relative to each of the discrete proton exchange membrane fuel cell modules; and

an air distribution assembly received in the enclosure and operably coupled with the subrack, the air distribution assembly delivering air to each of the proton exchange membrane fuel cell modules.

10

117. A power system housing as claimed in claim 116, wherein each of the discrete proton exchange membrane fuel cell modules produces electrical power, and wherein the power system housing further comprises a power conditioning assembly for receiving and inverting the electrical power produced  
15 by each of the discrete fuel cell modules.

118. A power system housing as claimed in claim 117, wherein the power conditioning assembly comprises:

an inverter for converting direct current voltage to alternating current  
20 voltage.

119. A power system housing as claimed in claim 116, wherein the discrete proton exchange membrane fuel cell modules produce thermal energy, and wherein the power system housing comprises a heat exchanger for capturing  
25 the thermal energy emitted by the discrete fuel cell modules.

120. A power system housing as claimed in claim 116, and further comprising a digital programmable controller electrically coupled with each of the discrete proton exchange membrane fuel cell modules.

5 121. A power system as claimed in claim 116, and further comprising a direct current bus which is mounted in the vicinity of the rearward edge of the subrack, and wherein the discrete proton exchange membrane fuel cells are releasably electrically coupled with the direct current bus.

10 122. A power system housing as claimed in claim 116, wherein the air distribution assembly further comprises:

a plenum made integral with each of the subracks, the plenum having an exhaust end which delivers air to each of the proton exchange membrane fuel cell modules supported on the subrack at a location intermediate the top and  
15 bottom portions thereof, and an intake end which receives both air which has passed through each of the proton exchange membrane fuel cell modules and air which comes from outside of the respective proton exchange membrane fuel cell modules;

an air movement assembly operably coupled to the plenum for moving the  
20 air from the intake end to the exhaust end of the plenum; and

an air mixing valve operably coupled with the plenum and controlling the amount of air which has passed through the respective fuel cells and which is recirculated back to each of the fuel cell modules.

25 123. A power system housing as claimed in claim 122, wherein the air mixing valve is disposed in selectively adjustable fluid metering relation relative to the intake end of the plenum, and the air movement assembly is disposed

intermediate the intake and exhaust ends of the plenum, and wherein the air mixing valve mixes both air which comes from outside of the respective discrete fuel cell modules and air which has passed through each of the discrete proton exchange membrane fuel cell modules.

5

124. A power system housing as claimed in claim 123, and further comprising:

temperature sensors for sensing the temperature of the air entering the discrete proton exchange membrane fuel cell modules, the outside air, and the  
10 air which has passed through each of the discrete proton exchange membrane fuel cell modules;

an actuator disposed in force transmitting relation relative to the air mixing valve, the actuator, when energized, moving the air mixing valve along a given course of travel between a first position and a second position, and  
15 wherein movement of the air mixing valve along the course of travel facilitates the selective mixing of the outside air with the air which has previously passed through the respective proton exchange membrane fuel cell modules; and

a controller electrically coupled in sensing relation relative to the temperature sensors and the actuator, the controller selectively energizing the  
20 actuator to move the air mixing valve along the course of travel to control the temperature of the air delivered to the exhaust end of the plenum.

125. A power system housing as claimed in claim 124, wherein the air mixing valve, when located in the first position, delivers outside air to the  
25 plenum, and in the second position, the air mixing valve delivers a variable mixture of both air which comes from outside the respective discrete proton

exchange membrane fuel cell modules and air which has passed through each of the respective discrete proton exchange membrane fuel cell modules.

126. A power system housing as claimed in claim 124, wherein the air  
5 movement assembly has a speed of operation which is variably adjustable, and wherein the controller is electrically coupled in controlling relation relative to the air movement assembly to control the speed of operation of the air movement assembly.

10 127. A power system housing as claimed in claim 116, wherein the discrete proton exchange membrane fuel cell modules produce thermal energy, and wherein the power system comprises a heat exchanger which is coupled in fluid flowing relation relative to the air distribution assembly, and which captures the thermal energy produced by each of the discrete proton exchange membrane  
15 fuel cell modules.

128. A power system housing comprising:  
an enclosure defining a cavity;  
a subrack mounted in the cavity, the subrack having forward and rearward  
20 edges, and top and bottom portions, the subrack supporting a plurality of discrete proton exchange membrane fuel cell modules in a given orientation in the cavity, each of the proton exchange membrane fuel cell modules producing direct current voltage, and wherein the top and bottom portions of the subrack are connected in fluid flowing relation relative to each of the discrete proton exchange  
25 membrane fuel cell modules;

a hydrogen distribution assembly received in the cavity of the enclosure and mounted in fluid flowing relation relative to each of the discrete proton

exchange membrane fuel cell modules, the hydrogen distribution assembly operably coupled to each of the discrete proton exchange membrane fuel cell modules in the vicinity of the rearward edge of the subrack;

an air distribution assembly received in the enclosure and coupled in fluid  
5 flowing relation relative to the top and bottom portions of the subrack, the air distribution assembly delivering air to each of the proton exchange membrane fuel cell modules, and wherein the air distribution assembly includes a plenum having an exhaust end which is positioned intermediate the top and bottom portions of the subrack and which delivers air to each of the discrete proton  
10 exchange membrane fuel cell modules, and an intake end connected at the top and bottom portions of the subrack and which receives both air which has passed through each proton exchange membrane fuel cell modules and air which comes from outside the respective proton exchange membrane fuel cell modules; an air movement assembly operably coupled to the plenum for moving the air  
15 in a given direction along the plenum to the individual proton exchange membrane fuel cell modules; and an air mixing valve operably coupled with the plenum and controlling the amount of air which has passed through the respective proton exchange membrane fuel cell modules and which is delivered back to each of the proton exchange membrane fuel cell modules; and  
20 an inverter electrically coupled with each of the proton exchange membrane fuel cell modules and converting the direct current voltage to alternating voltage.

129. A power system housing as claimed in claim 128, wherein the  
25 discrete proton exchange membrane fuel cell modules produce thermal energy, and wherein the power system housing comprises a heat exchanger for capturing the thermal energy emitted by the discrete fuel cell modules.

130. A power system housing as claimed in claim 128, and further comprising a digital programmable controller electrically coupled with each of the discrete proton exchange membrane fuel cell modules.

5 131. A power system housing as claimed in claim 128, and further comprising a direct current bus which is mounted in the vicinity of the rearward edge of the subrack, and wherein the discrete proton exchange membrane fuel cells are releasably electrically coupled with the direct current bus.

10 132. A power system housing as claimed in claim 128, wherein the air mixing valve is disposed in selectively adjustable fluid metering relation relative to the intake end of the plenum, and the air movement assembly is disposed intermediate the intake and exhaust ends of the plenum, and wherein the air mixing valve mixes both air which comes from outside of the respective discrete  
15 fuel cell modules and air which has passed through each of the discrete proton exchange membrane fuel cell modules.

133. A power system housing as claimed in claim 132, and further comprising:

20 temperature sensors for sensing the temperature of the air entering the discrete proton exchange membrane fuel cell modules, the outside air, and the air which has passed through each of the discrete proton exchange membrane fuel cell modules;

an actuator disposed in force transmitting relation relative to the air  
25 mixing valve, the actuator, when energized, moving the air mixing valve along a given course of travel and between a first position, and a second position, and wherein movement of the air mixing valve along the course of travel facilitates

the selective mixing of the outside air with the air which has previously passed through the respective proton exchange membrane fuel cell modules; and

a controller electrically coupled in sensing relation relative to the temperature sensors and the actuator, the controller selectively energizing the  
5 actuator to move the air mixing valve along the course of travel to control the temperature of the air delivered to the exhaust end of the plenum.

134. A power system housing as claimed in claim 133, wherein the air mixing valve, when located in the first closed position, delivers outside air to the  
10 plenum, and in the second position, the air mixing valve delivers a variable mixture of both air which comes from outside the respective discrete proton exchange membrane fuel cell modules, and air which has passed through each of the respective discrete proton exchange membrane fuel cell modules.

15 135. A power system housing as claimed in claim 133, wherein the air movement assembly has a speed of operation which is variably adjustable, and wherein the controller is electrically coupled in controlling relation relative to the air movement assembly to control the speed of operation of the air movement assembly.

20

136. A proton exchange membrane fuel cell module, comprising:

a hydrogen distribution frame defining a pair of discrete, substantially opposed cavities;

a membrane electrode diffusion assembly sealably mounted in each of the  
25 cavities which are defined by the hydrogen distribution frame, the membrane electrode diffusion assemblies each having opposite anode and cathode sides; and



a pair of current collectors each disposed in juxtaposed ohmic electrical contact with the opposite anode and cathode sides of each of the membrane electrode diffusion assemblies, and wherein the proton exchange membrane fuel cell module is self humidifying and produces a given amount of heat energy, and  
5 wherein the proton exchange membrane fuel cell module has a cathode air flow, and a preponderance of the heat energy is removed from the proton exchange membrane fuel cell module by the cathode air flow.

137. A proton exchange membrane fuel cell module as claimed in claim  
10 136, and further including a force application assembly which matingly cooperates with each of the cavities which are defined by the hydrogen distribution frame, the force application assembly comprising:

a cathode cover which partially occludes each of the respective cavities of the hydrogen distribution frame, the respective cathode covers individually  
15 releasably cooperating with each other and with the hydrogen distribution frame;

a pressure transfer assembly juxtaposed relative to the current collector which is disposed in ohmic electrical contact with cathode side of the membrane electrode diffusion assembly;

a pressure distribution assembly juxtaposed relative to the pressure transfer  
20 assembly; and

a biasing assembly oriented between the respective cathode covers and the pressure distribution assembly, and wherein the pressure transfer assembly applies a force of at least about 175 pounds per square inch which is realized between the membrane electrode diffusion assembly and the associated pair of current  
25 collectors.

138. A proton exchange membrane fuel cell module as claimed in claim 137, wherein the force distribution assembly further comprises:

a substantially non-compressible and deformable substrate; and

a compressible substrate mounted on the substantially non-compressible  
5 substrate and wherein the compressible substrate is in contact with the pressure transfer assembly.

139. A proton exchange membrane fuel cell module as claimed in claim 138, wherein the pressure distribution assembly facilitates the distribution of force  
10 from the adjoining cathode cover.

140. A proton exchange membrane fuel cell module as claimed in claim 137, wherein each cathode cover is fabricated from a substrate having a flexural modulus of at least about 1.00 million pounds per square inch, and wherein the  
15 hydrogen distribution frame is fabricated from a substrate having a flexural modulus of less than about 500,000 pounds per square inch, and a compressive strength of less than about 20,000 pounds per square inch.

141. A proton exchange membrane fuel cell module as claimed in claim  
20 137, wherein the biasing assemblies comprise metal wave springs which matingly cooperate with the adjoining cathode cover and the pressure distribution assembly.

142. A proton exchange membrane fuel cell module as claimed in claim 137, wherein the hydrogen distribution frame further defines a first passageway  
25 which permits the delivery of a source of hydrogen gas to each of the cavities and to the anode side of the membrane electrode diffusion assembly, and a second passageway which facilitates the removal of impurities, water and

unreacted hydrogen from each of the cavities, and wherein each of the cathode covers and the respective force application assemblies define a third passageway which permits the delivery of a source of air to each of the cavities and to the cathode side of each of the respective membrane electrode diffusion assemblies.

5

143. A proton exchange membrane fuel cell module as claimed in claim 142, wherein the pressure transfer assembly defines a given open area therebetween the adjacent current collector and the adjoining cathode cover, and wherein the open area defines, in part, the third passageway, and wherein the  
10 biasing assembly distributes the force transmitted by the respective cathode covers substantially uniformly over the second surface of each of the pressure plates.

144. A proton exchange membrane fuel cell module as claimed in claim 142, wherein the source of hydrogen gas is supplied by means of the first  
15 passageway to each of the cavities of the hydrogen distribution frame at a pressure of about 1 P.S.I.G. to about 10 P.S.I.G., and wherein the source of air is supplied at above ambient pressure.

145. A proton exchange membrane fuel cell module as claimed in claim  
20 137, wherein the pressure transfer assembly comprises an elongated main body having opposite ends and top and bottom surfaces, and a plurality of resilient members extend from the main body from a position near the bottom surface thereof.

25 146. A proton exchange membrane fuel cell module as claimed in claim 136, wherein the membrane electrode diffusion assembly comprises:

a solid proton conducting electrolyte membrane which has opposite anode and cathode sides;

individual catalytic anode and cathode electrodes disposed in ionic contact with the respective anode and cathode sides of the electrolyte membrane; and

5 a diffusion layer borne on each of the anode and cathode electrodes and which is electrically conductive and has a given porosity.

147. A proton exchange membrane fuel cell module as claimed in claim 146, wherein the diffusion layer further comprises:

10 a first diffusion layer borne on the individual anode and cathode electrodes and which is positioned in ohmic electrical contact with each electrode and which is electrically conductive and has a given pore size; and

a second diffusion layer borne on the first diffusion layer and which is positioned in ohmic electrical contact with the underlying first diffusion layer, and  
15 which further is electrically conductive and has a pore size which is greater than the given pore size of the first diffusion layer.

148. A proton exchange membrane fuel cell module as claimed in claim 146, wherein the electrolyte membrane has at least about a 20% molar  
20 concentration of a sulfonic acid.

149. A proton exchange membrane fuel cell module as claimed in claim 146, wherein the electrolyte membrane comprises crosslinked polymeric chains incorporating sulfonic acid groups.

25

150. A proton exchange membrane fuel cell module comprising:  
a hydrogen distribution frame defining a pair of cavities;

a membrane electrode diffusion assembly having opposite anode and cathode sides and which is sealably mounted on the hydrogen distribution frame and oriented in each of the cavities defined by the hydrogen distribution frame, the hydrogen distribution frame positioning the respective membrane electrode  
5 diffusion assemblies in predetermined substantially parallel spaced relation one to the other, and wherein the membrane electrode diffusion assembly comprises a solid proton conducting electrolyte membrane which has opposite anode and cathode sides; individual catalytic anode and cathode electrodes disposed in ionic contact with the respective anode and cathode sides of the electrolyte membrane;  
10 and a diffusion layer borne on each of the anode and cathode electrodes and which is electrically conductive and has a given pore size;

a pair of current collectors each disposed in juxtaposed ohmic electrical contact with the opposite anode and cathode sides of each of the membrane electrode diffusion assemblies;

15 a pressure transfer assembly disposed in force transmitting relation relative to each membrane electrode diffusion assembly and associated pair of current collectors which are received in each of the cavities defined by the hydrogen distribution frame;

a cathode cover partially occluding each of the respective cavities of the  
20 hydrogen distribution frame, the cathode covers matingly cooperating with the hydrogen distribution frame and with the pressure transfer assembly; and

a biasing member disposed intermediate the cathode cover and the adjacent pressure transfer assembly.

25 151. A proton exchange membrane fuel cell module as claimed in claim 150, and further including a pressure distribution assembly which comprises:

a substantially non-compressible and flexible substrate; and

a compressible substrate mounted on the non-compressible substrate and which is juxtaposed relative to the pressure transfer assembly.

152. A proton exchange membrane fuel cell module as claimed in claim  
5 151, wherein the non-compressible substrate is fabricated from a metal substrate; and the compressible substrate is fabricated from a thermoplastic foam.

153. A proton exchange membrane fuel cell module as claimed in claim  
152, wherein the biasing member comprises a plurality of metal wave springs  
10 which matingly cooperate with the adjoining cathode cover, and which forcibly engage the non-compressible substrate of the pressure distribution assembly.

154. A proton exchange membrane fuel cell module as claimed in claim  
150, wherein each of the cathode covers are fabricated from a substrate having  
15 a flexural modulus of at least about 1.00 million pounds per square inch, and wherein the hydrogen distribution frame is fabricated from a substrate having a flexural modulus of less than about 500,000 pounds per square inch, and a compressive strength of less than about 20,000 pounds per square inch.

20 155. A proton exchange membrane fuel cell module as claimed in claim 150, wherein the hydrogen distribution frame further defines a first passageway which permits the delivery of a source of hydrogen gas to each of the cavities and to the anode side of the membrane electrode diffusion assembly, and a second passageway which facilitates the removal of impurities, water and  
25 unreacted hydrogen from each of the cavities, and wherein each of the cathode covers and the respective pressure transfer assembly define a third passageway

which permits delivery of a source of air to each of the cavities and to the cathode side of each of the respective membrane electrode diffusion assemblies.

156. A proton exchange membrane fuel cell module as claimed in claim  
5 155, wherein the pressure transfer assembly defines a given open area between the adjacent current collector and the adjoining cathode cover, and wherein the open area defines, in part, the third passageway, and wherein the biasing member cooperates with the pressure transfer assembly to distribute the force transmitted by the respective cathode covers to discrete locations on the adjoining current  
10 collector.

157. A proton exchange membrane fuel cell module as claimed in claim  
155, wherein the source of hydrogen gas is supplied by means of the first passageway to each of the cavities of the hydrogen distribution frame at a  
15 pressure of about 1 P.S.I.G. to about 10 P.S.I.G., and wherein the source of air is supplied at above ambient pressure.

158. A proton exchange membrane fuel cell module as claimed in claim  
150, wherein the pressure transfer assembly comprises an elongated main body;  
20 and a plurality of deformable members extend therefrom.

159. A proton exchange membrane fuel cell module comprising:  
a hydrogen distribution frame defining multiple pairs of discretely opposed cavities, the hydrogen distribution frame further defining first and second  
25 passageways, the first passageway facilitating the delivery of a source of hydrogen gas to each cavity, and the second passageway facilitating the removal of unreacted hydrogen gas, water and impurities from each of the cavities;

a membrane electrode diffusion assembly having opposite anode and cathode sides and which is sealably mounted on the hydrogen distribution frame and positioned in each of the cavities, the membrane electrode diffusion assembly having a solid proton conducting electrolyte membrane with opposite anode and cathode sides, and which has at least about a 20% molar concentration of sulfonic acid; individual anode and cathode electrodes disposed in ionic contact with the respective anode and cathode sides of the electrolyte membrane; and a diffusion layer borne on each of the anode and cathode electrodes;

a pair of current collectors individually disposed in juxtaposed ohmic electrical contact with the diffusion layer borne on each of the anode and cathode electrodes, the current collectors each having a base substrate which is electrically conductive; and a contact layer over the base substrate, and wherein the individual current collectors have a given surface area of which at least about 70% is open area;

a pressure transfer assembly juxtaposed relative to the current collector which is oriented in ohmic electrical contact with the cathode side of the membrane electrode diffusion assembly, and wherein the pressure transfer assembly has an elongated main body having top and bottom surfaces, and a plurality of resilient members depend downwardly from the bottom surface thereof and forcibly engage the current collector which is disposed in ohmic electrical contact with the cathode side of the membrane electrode diffusion assembly, and wherein the pressure transfer assembly defines in part a third passageway which facilitates the delivery of a source of air to the cathode side of the membrane electrode diffusion assembly;

a cathode cover disposed in partially occluding relation relative to each of the cavities, and matingly cooperating with the pressure transfer assembly, the



cathode cover, in part defining the third passageway, the individual cathode covers matingly engaging each other, and the hydrogen distribution frame; and  
a biasing assembly positioned between the respective cathode covers, and the pressure transfer assembly, the biasing assembly transferring by means of the  
5 force transfer assembly substantially uniform force such that at least about 175 pounds per square inch is generated between each membrane electrode diffusion assembly and associated pair of current collectors.

160. A membrane electrode diffusion assembly comprising:  
10 a solid proton conducting electrolyte membrane which has opposite anode and cathode sides;  
individual catalytic anode and cathode electrodes formed on the proton conducting electrolyte membrane and which are in ionic contact therewith; and  
a non-catalytic electrically conductive diffusion layer affixed on the anode  
15 and cathode electrodes and which has a given porosity.

161. A membrane electrode diffusion assembly as claimed in claim 160, wherein the non-catalytic electrically conductive diffusion layer has a first diffusion layer which is positioned in ohmic electrical contact with each of the electrodes;  
20 and a second diffusion layer positioned in ohmic electrical contact with the underlying first diffusion layer.

162. A membrane electrode diffusion assembly as claimed in claim 161, wherein the first diffusion layer comprises a coating of particulate carbon  
25 suspended in a binding resin; and the second diffusion layer comprises a porous hydrophobic carbon backing layer.

163. A membrane electrode diffusion assembly as claimed in claim 162, wherein the binding resin is substantially hydrophobic and is selected from the group consisting essentially of perfluorinated hydrocarbons; and wherein the first diffusion layer has about 20% to about 90%, by weight, of the particulate  
5 carbon.

164. A membrane electrode diffusion assembly as claimed in claim 161, wherein the porous hydrophobic backing layer forming the second diffusion layer is selected from the group consisting essentially of carbon cloth, carbon paper,  
10 or carbon sponge which has been rendered hydrophobic.

165. A membrane electrode diffusion assembly as claimed in claim 164, wherein the hydrophobic backing layer is coated with a liquid suspension comprising about 95% to about 99% by weight of water; and about 1% to about  
15 5% by weight of a surfactant.

166. A membrane electrode diffusion assembly as claimed in claim 161, wherein the first diffusion layer is a composite coating formed of successive layers of the first diffusion layer, each of the successive layers having a given  
20 hydrophobicity, and wherein the first diffusion layer has a hydrophobic gradient, and wherein the hydrophobic gradient is established by adjusting the hydrophobicity of the successive layers forming the composite layer.

167. A membrane electrode diffusion assembly as claimed in claim 166,  
25 wherein the successive layers closest to the second diffusion layer are the least hydrophobic of all of the successive layers.

168. A membrane electrode diffusion assembly as claimed in claim 166, wherein the successive layers closest to the second diffusion layer are the most hydrophobic of all of the successive layers.

5 169. A membrane electrode diffusion assembly as claimed in claim 160, wherein the non-catalytic electrically conductive diffusion layer is borne on a third diffusion layers.

170. A membrane electrode diffusion assembly as claimed in claim 160,  
10 wherein the diffusion layer has a variable porosity.

171. A membrane electrode diffusion assembly as claimed in claim 160, wherein a thermoplastic binding agent is positioned between the anode and cathode electrodes and the overlying diffusion layer and is effective to bind the  
15 diffusion layer to the underlying anode and cathode electrode.

172. A membrane electrode diffusion assembly as claimed in claim 171, wherein the thermoplastic binding agent is selected from the group consisting essentially of polyethylene or wax.

20

173. A membrane electrode diffusion assembly as claimed in claim 160, wherein the individual anode and cathode electrodes include an electrolyte, and wherein the electrolyte and the solid proton conducting electrolyte membrane include a cross-linked copolymer incorporating sulfonic acid groups.

25

174. A membrane electrode diffusion assembly as claimed in claim 160, wherein the individual anode and cathode electrodes comprise:

particulate carbon;  
a catalyst; and  
a cross-linked copolymer incorporating sulfonic acid groups.

5           175.    A membrane electrode diffusion assembly as claimed in claim 160, wherein the individual anode and cathode electrodes are gas diffusing, and include an electrolyte, and wherein the electrolyte and the solid proton conducting membrane include a cross-linked copolymers having sulfonic acid groups.

10

176.    A membrane electrode diffusion assembly comprising:  
a solid proton conducting electrolyte membrane which has opposite anode and cathode sides;  
individual catalytic anode and cathode electrodes formed on the proton  
15 conducting electrolyte membrane and which are in ionic contact therewith; and  
a non-catalytic electrically conductive diffusion layer affixed on the anode and cathode electrodes and which has a given porosity, and wherein the non-catalytic electrically conductive diffusion layer has a first diffusion layer which is positioned in ohmic electrical contact with each of the electrodes; and a second  
20 diffusion layer positioned in ohmic electrical contact with the underlying first diffusion layer, and wherein the diffusion layer has a variable porosity.

177.    A membrane electrode diffusion assembly as claimed in claim 176, wherein the first diffusion layer comprises a coating of particulate carbon  
25 suspended in a binding resin; and the second diffusion layer comprises a porous hydrophobic carbon backing layer.

178. A membrane electrode diffusion assembly as claimed in claim 177, wherein the binding resin is substantially hydrophobic and is selected from the group consisting essentially of fluorinated hydrocarbons; and wherein the first diffusion layer has about 20% to about 90%, by weight, of the particulate  
5 carbon.

179. A membrane electrode diffusion assembly as claimed in claim 177, wherein the porous hydrophobic backing layer forming the second diffusion layer is selected from the group consisting essentially of carbon cloth, carbon paper,  
10 or carbon sponge which has been rendered hydrophobic.

180. A membrane electrode diffusion assembly as claimed in claim 179, wherein the hydrophobic backing layer is coated with a liquid suspension comprising about 95% to about 99% by weight of water; and about 1% to about  
15 5% by weight of a compatible surfactant.

181. A membrane electrode diffusion assembly as claimed in claim 176, wherein the first diffusion layer is a composite coating formed of successive layers of the first diffusion layer, each of the successive layers having a given  
20 hydrophobicity, and wherein the first diffusion layer has a hydrophobic gradient, and wherein the hydrophobic gradient is established by adjusting the hydrophobicity of the successive layers forming the composite layer.

182. A membrane electrode diffusion assembly as claimed in claim 181,  
25 wherein the successive layers closest to the second diffusion layer are the least hydrophobic of all of the successive layers.

## 100

183. A membrane electrode diffusion assembly as claimed in claim 181, wherein the successive layers closest to the second diffusion layer are the most hydrophobic of all of the successive layers.

5 184. A membrane electrode diffusion assembly as claimed in claim 176, wherein a thermoplastic binding agent is positioned between the anode and cathode electrodes and the overlying diffusion layer and which is effective to bind the diffusion layer to the underlying anode and cathode electrode.

10 185. A membrane electrode diffusion assembly as claimed in claim 184, wherein the thermoplastic binding agent is selected from the group consisting essentially of polyethylene and wax.

15 186. A membrane electrode diffusion assembly as claimed in claim 176, wherein the individual anode and cathode electrodes include an electrolyte, and wherein the electrolyte and the solid proton conducting electrolyte membrane include a cross-linked copolymer incorporating sulfonic acid groups.

20 187. A membrane electrode diffusion assembly as claimed in claim 176, wherein the individual anode and cathode electrodes comprise:  
particulate carbon;  
a catalyst; and  
a cross-linked copolymer incorporating sulfonic acid groups.

25 188. A membrane electrode diffusion assembly as claimed in claim 176, wherein the individual anode and cathode electrodes are gas diffusing, and include an electrolyte, and wherein the electrolyte and the solid proton

conducting membrane include a cross-linked copolymers having sulfonic acid groups.

189. A membrane electrode diffusion assembly comprising:

5 a solid proton conducting electrolyte membrane which has opposite anode and cathode sides;

individual catalytic anode and cathode electrodes formed on the proton conducting electrolyte membrane and which are in ionic contact therewith; and

a non-catalytic electrically conductive diffusion layer affixed on the anode  
10 and cathode electrodes and which has a given porosity, and wherein the non-catalytic electrically conductive diffusion layer has a first diffusion layer which is positioned in ohmic electrical contact with each of the electrodes, and wherein the first diffusion layer has a hydrophobic gradient; and a second diffusion layer positioned in ohmic electrical contact with the underlying first diffusion layer, and  
15 wherein the diffusion layer has a variable porosity; and

a thermoplastic binding agent is positioned between the anode and cathode electrodes and the overlying diffusion layer and which is effective to bind the diffusion layer to the underlying anode and cathode electrode.

20 190. A membrane electrode diffusion assembly as claimed in claim 189, wherein the first diffusion layer comprises a coating of particulate carbon suspended in a binding resin; and the second diffusion layer comprises a porous hydrophobic carbon backing layer.

25 191. A membrane electrode diffusion assembly as claimed in claim 190, wherein the binding resin is substantially hydrophobic and is selected from the group consisting essentially of fluorinated hydrocarbons; and wherein the first

diffusion layer has about 20% to about 90%, by weight, of the particulate carbon.

192. A membrane electrode diffusion assembly as claimed in claim 190,  
5 wherein the porous hydrophobic backing layer forming the second diffusion layer is selected from the group consisting essentially of carbon cloth, carbon paper, or carbon sponge which has been rendered hydrophobic.

193. A membrane electrode diffusion assembly as claimed in claim 192,  
10 wherein the hydrophobic backing layer is coated with a liquid suspension comprising about 95% to about 99% by weight of water; about 1% to about 5% by weight of alcohol; and about 1% to about 5% by weight of a compatible surfactant.

194. A membrane electrode diffusion assembly as claimed in claim 192,  
15 wherein the first diffusion layer is a composite coating formed of successive layers of the first diffusion layer, each of the successive layers having a given hydrophobicity, and wherein the hydrophobic gradient is established by adjusting the hydrophobicity of the successive layers forming the composite layer.

20

195. A membrane electrode diffusion assembly as claimed in claim 194,  
wherein the successive layers closest to the second diffusion layer are the least hydrophobic of all of the successive layers.

25 196. A membrane electrode diffusion assembly as claimed in claim 194,  
wherein the successive layers closest to the second diffusion layer are the most hydrophobic of all of the successive layers.



197. A membrane electrode diffusion assembly as claimed in claim 189, wherein the diffusion layer has a variable porosity.

198. An electrolyte membrane comprising:

5 crosslinked polymeric chains incorporating sulfonic acid groups.

199. An electrolyte membrane as claimed in claim 198, wherein the crosslinked polymeric chains are formed from monomeric units which are selected from the group consisting essentially of:

10 poly (ethylene glycol) methacrylate, poly (propylene glycol) methacrylate, poly (ethylene glycol) ethyl ether methacrylate, and poly (propylene glycol) methyl ether methacrylate, hydroxypropyl methacrylate, 2-hydroxyethyl methacrylate, the acrylate analogs, and 4-hydroxybutyl acrylate .

15 200. An electrolyte membrane as claimed in claim 198, wherein the sulfonic acid groups are selected from the group consisting essentially of:

3-alkoxy-2-hydroxy-1-propanesulfonic acid, 4-styrenesulfonic acid, vinylsulfonic acid, 3-sulfopropyl methacrylate, 3-sulfopropylacrylate and fluorinated derivatives thereof.

20

201. An electrolyte membrane as claimed in claim 198, and further comprising a crosslinking agent which is selected from the group consisting essentially of:

ethylene glycol divinyl ether, diethylene glycol divinyl ether, triethylene glycol divinyl ether, ethylene glycol dimethacrylate, diethylene glycol dimethacrylate, trimethylene glycol dimethacrylate, glycerol dimethacrylate, diallyloxyacetic acid, and allylmethacrylate.

202. An electrolyte membrane comprising:

crosslinked copolymeric chains having sulfonic acid groups, and wherein the crosslinked copolymeric chains comprise methacrylate and a crosslinking agent.

5 203. An electrolyte membrane as claimed in claim 202, wherein the sulfonic acid groups are selected from the group consisting essentially of 3-alkoxy-2-hydroxy-1-propane sulfonic acid, 4-styrenesulfonic acid, vinyl sulfonic acid; and 3-sulfopropyl methacrylate, 3-sulfapropylacrylate, and fluorinated derivatives thereof; and the crosslinking agent is selected from the group consisting essentially of  
10 ethylene glycol divinyl ether, diethylene glycol divinyl ether, triethylene glycol divinyl ether, ethylene glycol dimethacrylate, diethylene glycol dimethacrylate, triethylene glycol dimethacrylate, glycerol dimethacrylate, diallyloxyacetic acid, allylmethacrylate and mixtures thereof.

15 204. An electrolyte membrane comprising:

about 35% to about 50% by molar concentration of a methacrylate monomer;

about 30% to about 50% by molar concentration of an acrylate monomer;

about 25% to about 45% by molar concentration of a sulfonic acid; and

20 about 5% to about 20% by molar concentration of a compatible crosslinking agent.

205. An electrolyte membrane as claimed in claim 204, wherein the glass transition temperature of the electrolyte membrane is greater than about  
25 110 degrees C., and wherein the electrolyte membrane has a thickness of less than about 1 millimeter, and is substantially stable in the presence of water, and operational at temperatures of less than about 80 degrees C.

206. An electrolyte membrane as claimed in claim 204, and further comprising a compatible plasticizer.

207. An electrolyte membrane as claimed in claim 204, wherein the  
5 electrolyte membrane further comprises:

a porous supporting matrix which is constructed integrally with the electrolyte membrane.

208. An electrolyte membrane as claimed in claim 207, wherein the  
10 porous supporting matrix does not reactively produce hydrogen ions and is dielectric.

209. An electrolyte membrane as claimed in claim 207, wherein the porous supporting matrix is substantially inert, and has a porosity of about 30%  
15 to about 80%.

210. An electrolyte membrane as claimed in claim 209, wherein the electrolyte membrane has a given proton conductivity which is proportional to the porosity of the supporting matrix.

20

211. An electrolyte membrane comprising:

a polymethacrylate;

an acrylate or methacrylate;

a sulfonic acid;

25 a crosslinking agent; and

a compatible plastizer.

212. An electrolyte membrane as claimed in claim 211, wherein the polymethacrylate is selected from the group consisting essentially of:

poly (ethylene glycol) methacrylate, poly (propylene glycol) methacrylate, poly (ethylene glycol) ethyl ether methacrylate, and poly (propylene glycol) methyl ether methacrylate, hydroxypropyl methacrylate, 2-hydroxyethyl methacrylate, the acrylate analogs, and 4-hydroxybutyl acrylate .

213. An electrolyte membrane as claimed in claim 211, wherein the polymethacrylate is about 20% to about 90% by weight.

10

214. An electrolyte membrane as claimed in claim 211, wherein the sulfonic acid is selected from the group consisting essentially of:

3-alkoxy-2-hydroxy-1-propanesulfonic acid, 4-styrenesulfonic acid, vinylsulfonic acid, and 3-sulfopropyl methacrylate, 3-sulfopropylacrylate, and fluorinated derivatives thereof.

15

215. An electrolyte membrane as claimed in claim 211, wherein the sulfonic acid comprises about 25% to about 45% by molar concentration.

20 216. A electrolyte membrane as claimed in claim 211, wherein the crosslinking agent is selected from the group consisting essentially of:

ethylene glycol divinyl ether, diethylene glycol divinyl ether, triethylene glycol divinyl ether, ethylene glycol dimethacrylate, diethylene glycol dimethacrylate, triethylene glycol dimethacrylate, glycerol dimethacrylate and mixtures thereof.

25

217. An electrolyte membrane as claimed in claim 211, wherein the crosslinking agent is about 5% to about 20% by molar concentration.

218. An electrolyte membrane comprising:

at least about 10% to about 50% by molar concentration of a copolymer which has monomeric units which are selected from the group consisting essentially of poly (ethylene glycol) methacrylate, poly (propylene glycol) methacrylate, poly (ethylene glycol) ethyl ether methacrylate, poly (propylene glycol) methyl ether methacrylate, hydroxypropyl methacrylate, 2-hydroxyethyl methacrylate, acrylate analogs and 4-hydroxybutyl acrylate;

at least about 25% to about 45% by molar concentration of an acid selected from the group consisting essentially of 3-alkyloxy-2-hydroxy-1-propanesulfonic acid, 4-styrenesulfonic acid, vinylsulfonic acid, 3-sulfopropyl methacrylate, 3-sulfopropylacrylate and fluorinated derivatives thereof;

at least about 5% to about 20% by molar concentration of a crosslinking agent selected from the group consisting essentially of ethylene glycol divinyl ether, diethylene glycol divinyl ether, trimethylene glycol divinyl ether, ethylene glycol dimethacrylate, diethylene glycol dimethacrylate, trimethylene glycol dimethacrylate, glycerol dimethacrylate, diallyloxyacetic acid, and allylmethacrylate;

a compatible plasticizer; and

a support matrix having a given minimum porosity, and which is not electrically conductive.

20

219. A current collector comprising:

a base substrate which is electrically conductive; and

a contact layer over the base substrate and which is galvanically cathodic, electrically conductive, and oxygen stable.

25

220. A current collector as claimed in claim 219, wherein the contact layer consists essentially of substances having constituent elements from Groups

IVB of the periodic table of elements, and wherein the substances are further characterized by their ability to form an electrically conductive nitride.

221. A current collector as claimed in claim 220, and further  
5 comprising:

a protection layer which will passivate if exposed to oxygen; and  
an electrolyte/oxygen exclusion layer.

222. A current collector as claimed in claim 219, wherein the base  
10 substrate is selected from the group consisting essentially of nickel, copper and chromium containing stainless steel; and wherein the contact layer is selected from the group consisting essentially of palladium, platinum, rhodium, ruthenium, iridium, osmium; and wherein each current collector further comprises an electrically conductive adhesive positioned between each current collector and the  
15 membrane electrode diffusion assembly.

223. A current collector as claimed in claim 219, wherein the base  
substrate has a thickness of about 0.1 millimeters to about 1.3 millimeters; and  
wherein the contact layer has a thickness of about 0.02 to about 2 microns.  
20

224. A current collector as claimed in claim 219, wherein the base  
substrate has a given surface area of which at least about 70% is open area.

225. A method of forming a diffusion layer for use with a membrane  
25 electrode diffusion assembly, comprising:

providing a carbon backing layer which is selected from the group  
consisting essentially of carbon cloth, carbon paper, or carbon sponge;

applying a hydrophobic polymer to the carbon backing layer; and  
sintering the carbon backing layer at a temperature greater than the  
melting point of the hydrophobic polymer.

5           226.    A method as claimed in claim 225, wherein the hydrophobic  
polymer is selected from the group consisting essentially of fluorinated  
hydrocarbons.

          227.    A method as claimed in claim 225, wherein the sintering step  
10 takes place at a temperature of about 275 degrees to about 365 degrees C.

          228.    A method of forming a diffusion layer for use with a membrane  
electrode diffusion assembly, comprising:  
          providing a porous carbon backing layer; and  
15           applying a porous coating comprising a slurry of particulate carbon, a  
binding resin, and a delivery fluid onto the porous carbon backing layer.

          229.    A method as claimed in claim 228, wherein the porous carbon  
backing layer is selected from the group consisting essentially of carbon cloth,  
20 carbon paper, and carbon sponge.

          230.    A method as claimed in claim 228, wherein the binding resin is  
hydrophobic and comprises a fluorinated hydrocarbon.

25           231.    A method as claimed in claim 228, wherein the porous coating  
comprises at least about 20% to about 90%, by weight of the particulate carbon.

232. A method as claimed in claim 228, wherein the delivery fluid consists essentially of water, and a compatible surfactant.

233. A method as claimed in claim 232, wherein the delivery fluid  
5 consists essentially of:

about 95% to about 99% by weight of water; and

about 1% to about 5% by weight of a compatible surfactant.

234. A method as claimed in claim 233, wherein the alcohol is selected  
10 from the group consisting essentially of 2-butoxyethanol, methanol, ethanol and isopropanol.

235. A method as claimed in claim 233, wherein the compatible  
surfactant comprises ammonium hydroxide.

15

236. A method as claimed in claim 228, and further comprising:  
removing the delivery fluid, thereby depositing the particulate carbon, and  
the binding resin.

20 237. A method as claimed in claim 236, wherein the delivery fluid is removed by applying heat energy to same.

238. A method as claimed in claim 236, and after removing the  
delivery fluid, the method further comprises:

25 sintering the resulting diffusion layer at a temperature effective to melt the binding resin.



239. A method as claimed in claim 238, and after the step of sintering, the method further comprises:

applying a predetermined pattern of pressure to the diffusion layer at a given value that is effective to vary the porosity of the resulting diffusion layer.

5

240. A method as claimed in claim 239, and further comprising:

applying a thermoplastic binding emulsion onto the surface of the diffusion layer.

10

241. A method as claimed in claim 240, wherein the thermoplastic emulsion is selected from the group consisting essentially of polyethylene or wax.

242. A method as claimed in claim 228, and further comprising:

removing the delivery fluid, thereby depositing the particulate carbon and the binding resin, and wherein the porous carbon coating is applied in a plurality of successive coats.

15

243. A method as claimed in claim 242, wherein the successive coats

of the porous carbon coating have a given hydrophobicity and wherein the hydrophobic gradient is adjustable by altering the hydrophobicity of each of the successive coats.

20

244. A method as claimed in claim 240, wherein the binding resins are

selected from the group consisting essentially of hydrophobic and hydrophilic binding resins, and wherein the given hydrophobicity of each coat is adjusted by providing a predetermined mixture of the hydrophobic and hydrophilic binding resins.

25

245. A method as claimed in claim 244, wherein the coatings applied closest to the porous carbon backing layer are the most hydrophobic of all the coatings.

5 246. A method as claimed in claim 244, wherein the coatings applied closest to the porous carbon backing layer are the least hydrophobic of all the coatings.

247. A method as claimed in claim 228, wherein the porous coating  
10 has a hydrophobic gradient.

248. A method as claimed in claim 247, wherein the hydrophobic gradient is varied by adjusting the ratio of the hydrophobic binding resin to the particulate carbon.

15

249. A method of forming a diffusion layer for use with a membrane electrode diffusion assembly, comprising:

providing a porous carbon backing layer;

20 applying a porous coating comprising a slurry of particulate carbon, a binding resin, and a delivery fluid onto the porous carbon backing layer, and wherein the porous coating has a hydrophobic gradient and comprises at least about 20% to about 90%, by weight of the particulate carbon;

removing the delivery fluid, thereby depositing the particulate carbon and the binding resin;

25 sintering the resulting diffusion layer at a temperature effective to melt the binding resin;

applying a predetermined pattern of pressure to the diffusion layer at a given value that is effective to vary the porosity of the resulting diffusion layer; and

applying a thermoplastic binding emulsion onto the surface of the diffusion  
5 layer.

250. A method as claimed in claim 249, wherein the porous carbon backing layer is selected from the group consisting essentially of carbon cloth, carbon paper, and carbon sponge.

10

251. A method as claimed in claim 249, wherein the binding resin is hydrophobic and comprises a fluorinated hydrocarbon.

252. A method as claimed in claim 249, wherein the delivery fluid  
15 consists essentially of water, an alcohol, and a compatible surfactant.

253. A method as claimed in claim 249, wherein the porous carbon coating is applied in a plurality of successive coats.

20 254. A method as claimed in claim 249, wherein the delivery fluid is removed by applying heat energy to same.

25 255. A method as claimed in claim 249, wherein the successive coats of the porous carbon coating have a given hydrophobicity and wherein the hydrophobic gradient is adjustable by altering the hydrophobicity of each of the successive coats.

256. A method as claimed in claim 255, wherein the binding resins are selected from the group consisting essentially of hydrophobic and hydrophilic binding resins, and wherein the given hydrophobicity of each coat is adjusted by providing a predetermined mixture of the hydrophobic and hydrophilic binding  
5 resins.

257. A method as claimed in claim 256, wherein the coatings applied closest to the porous carbon backing layer are the most hydrophobic of all the coatings.

10

258. A method as claimed in claim 256, wherein the coatings applied closest to the porous carbon backing layer are the least hydrophobic of all the coatings.

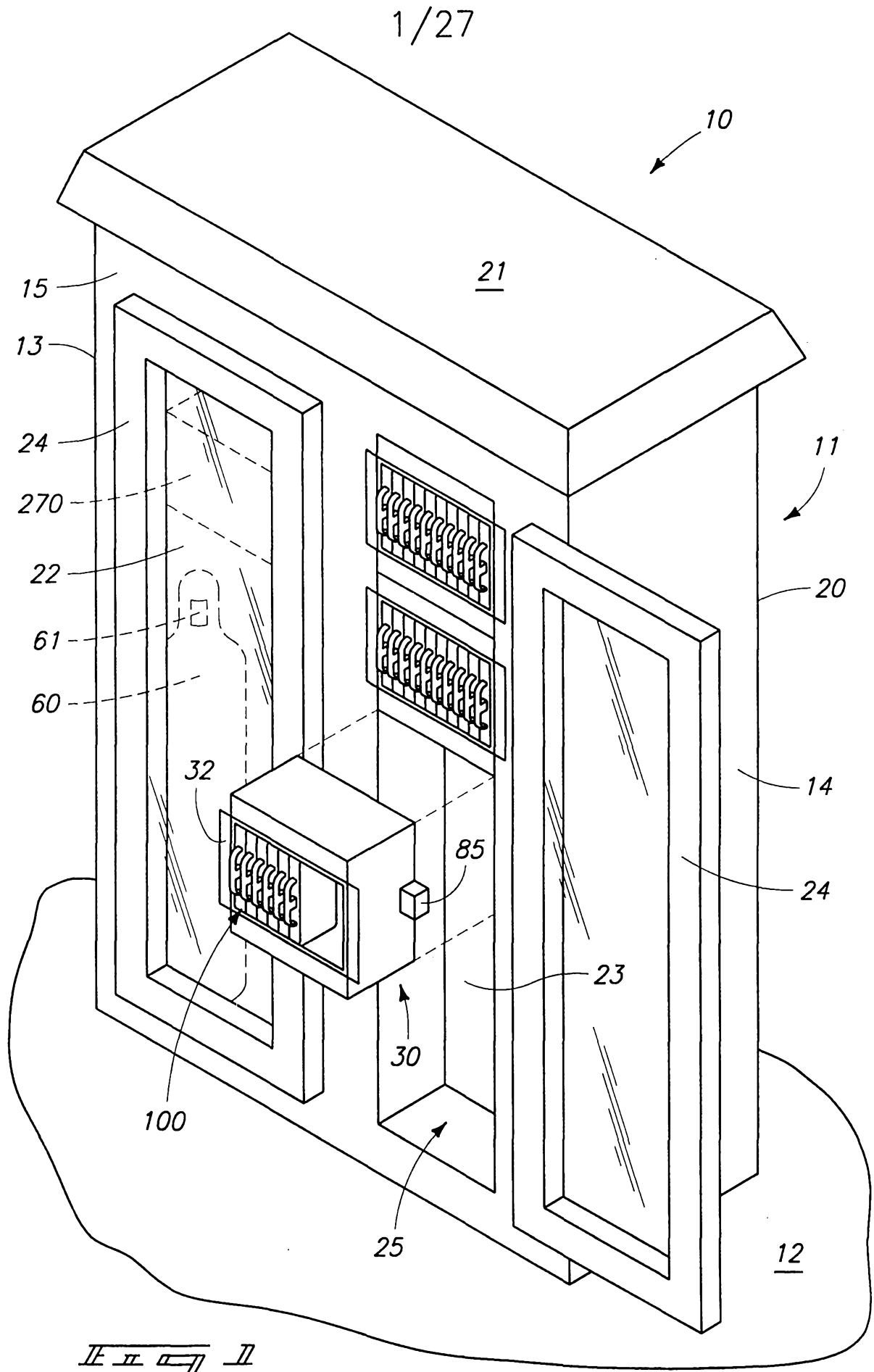

2/27

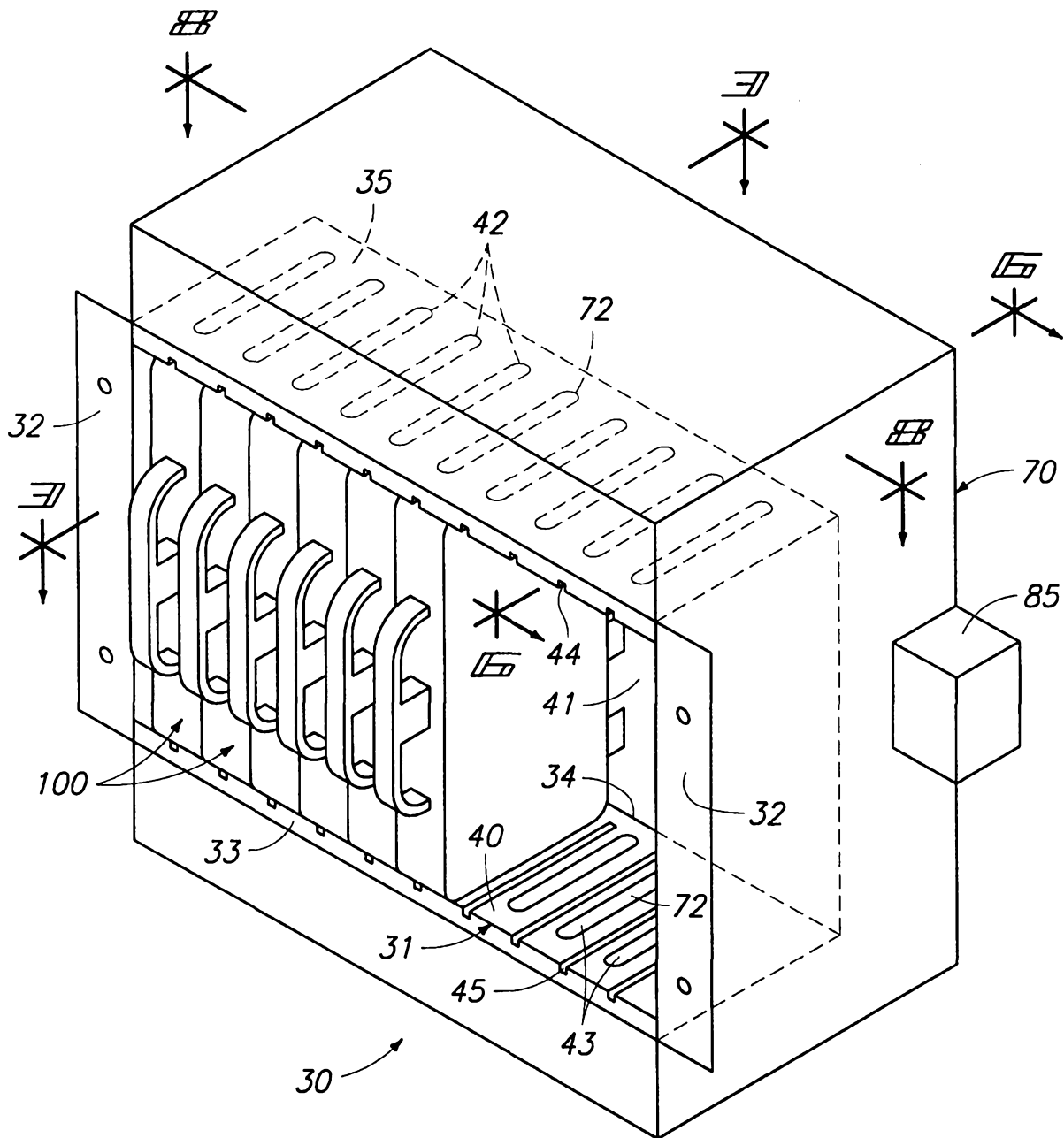

*II 11 12 13*

3/27

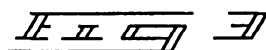
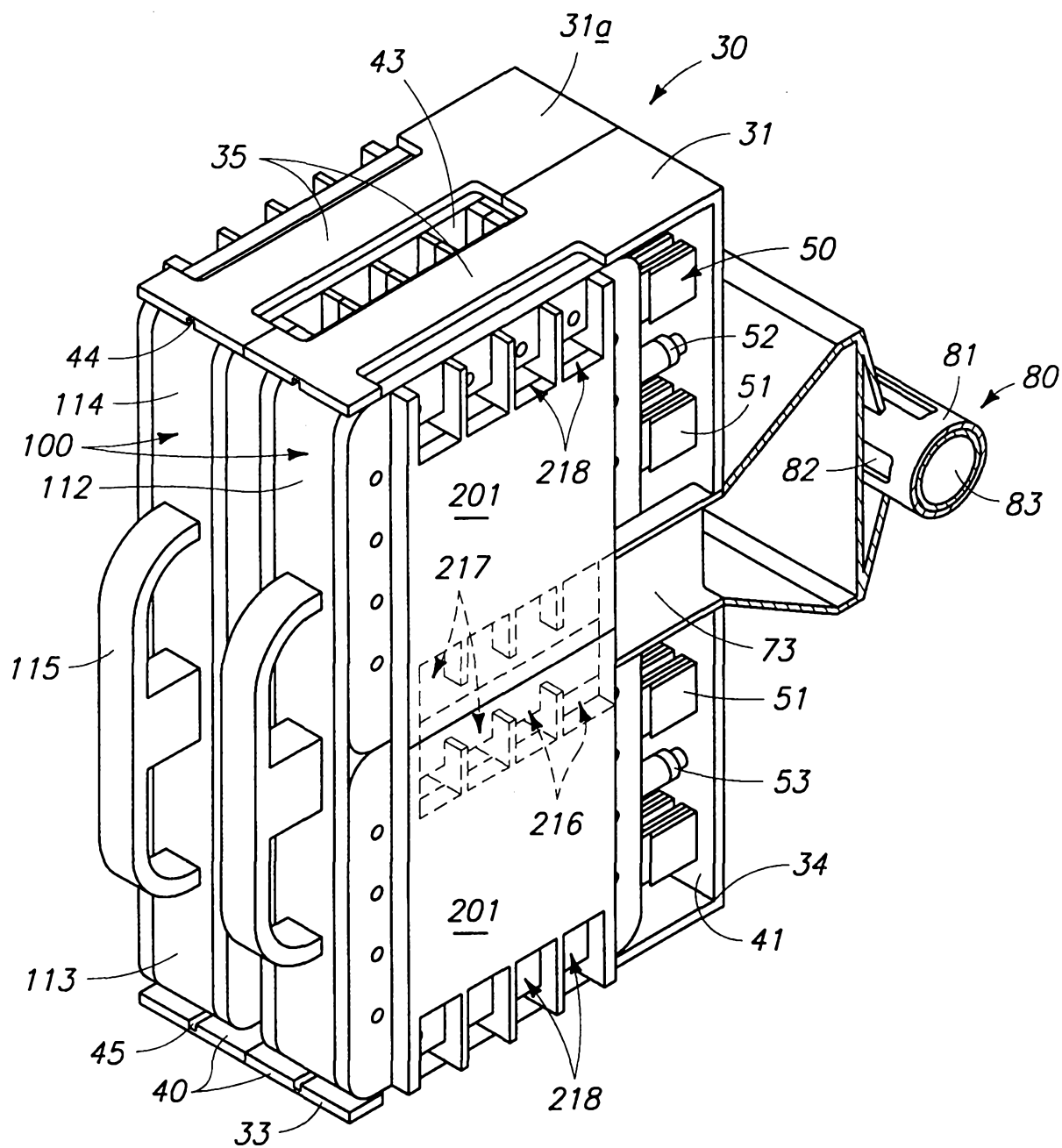

4/27

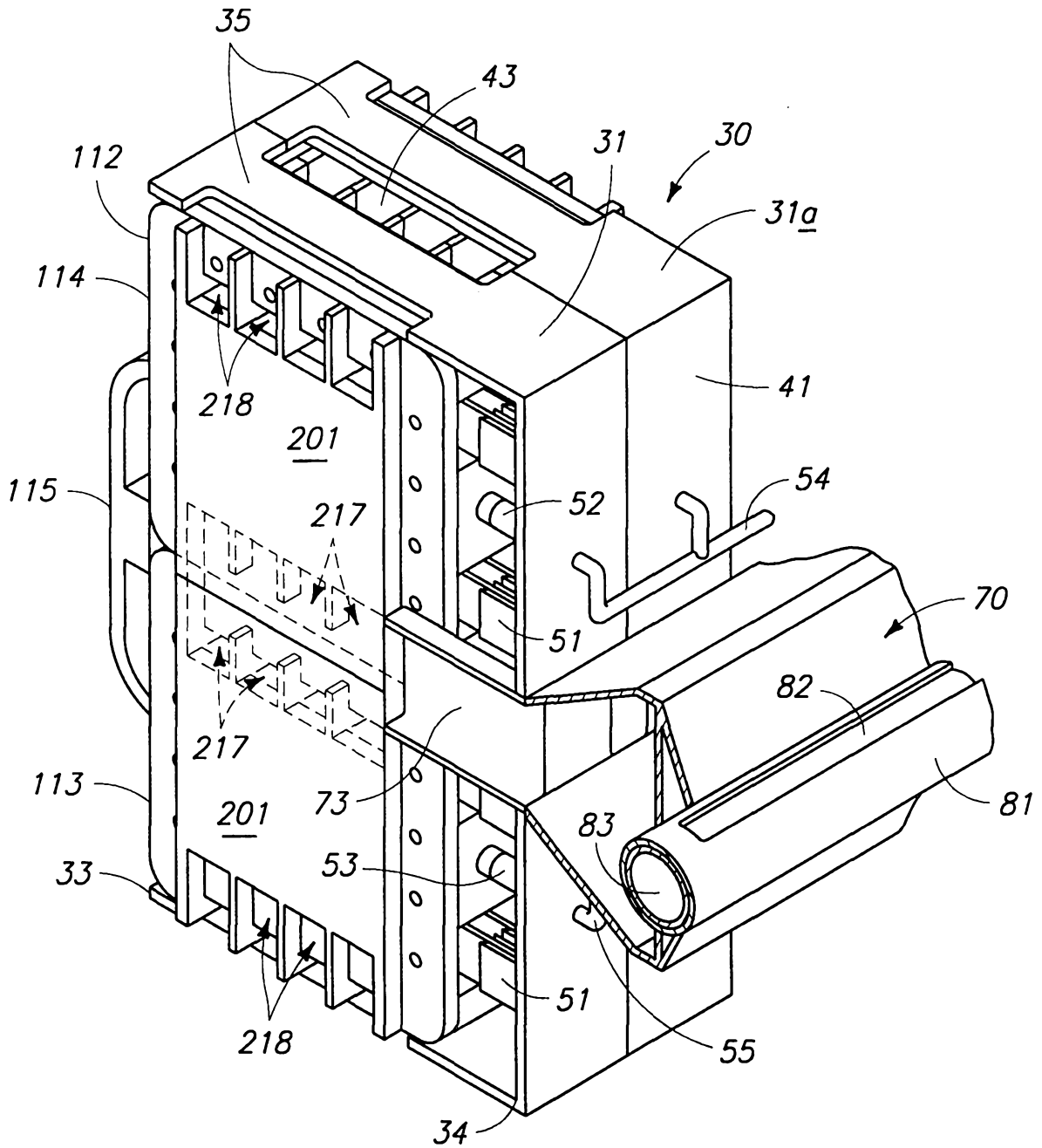
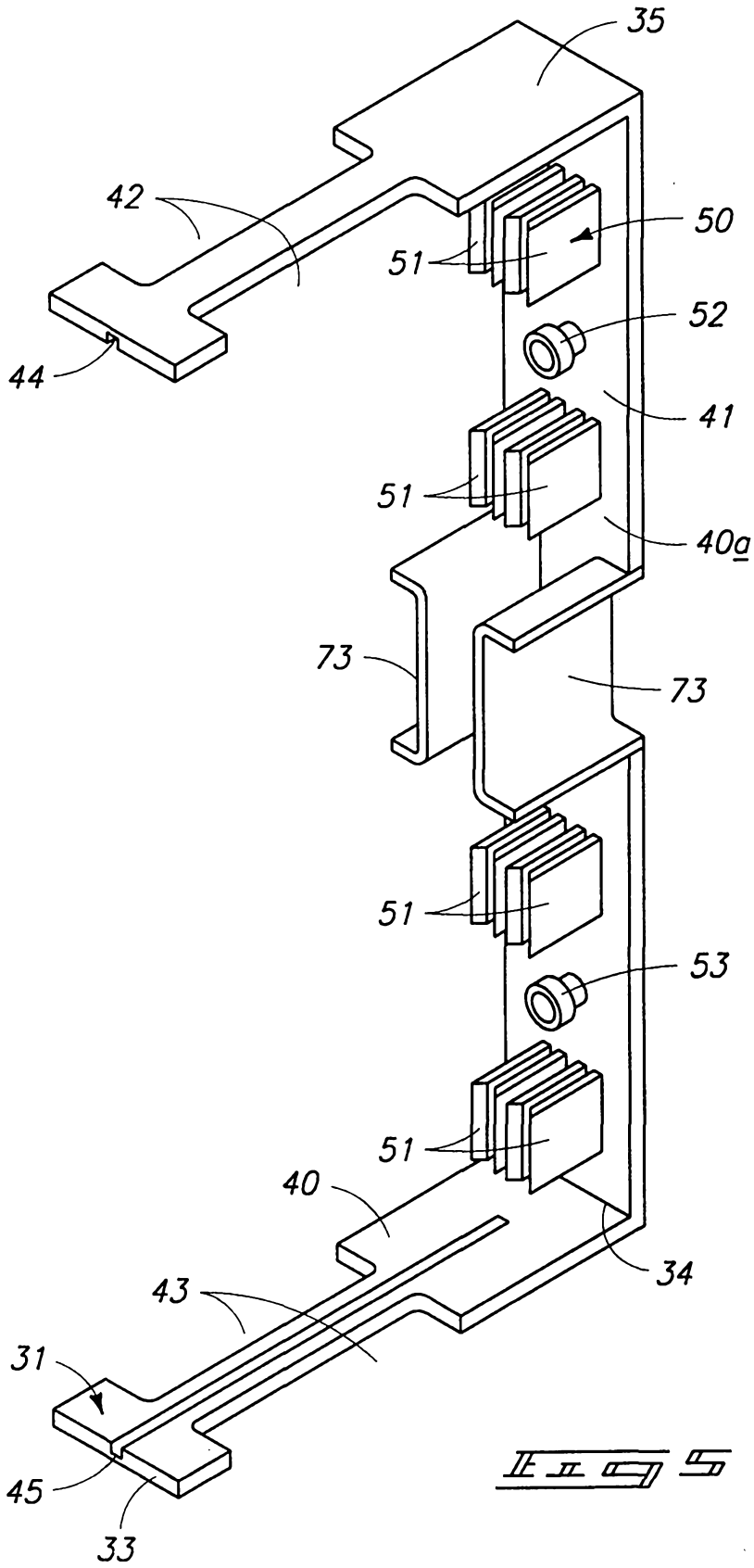

FIG. 4



5/27



6/27

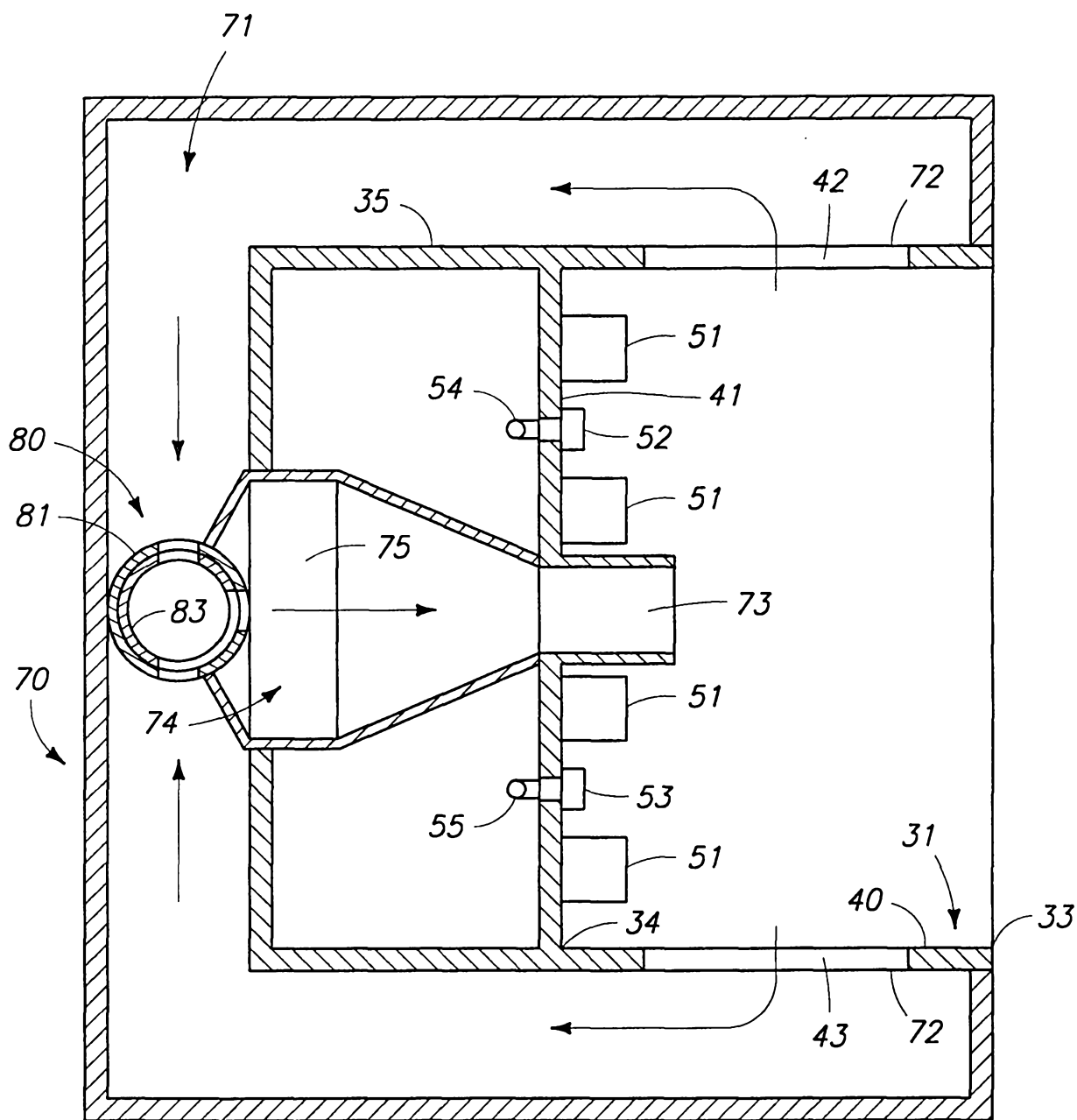

FIG. 6

7/27

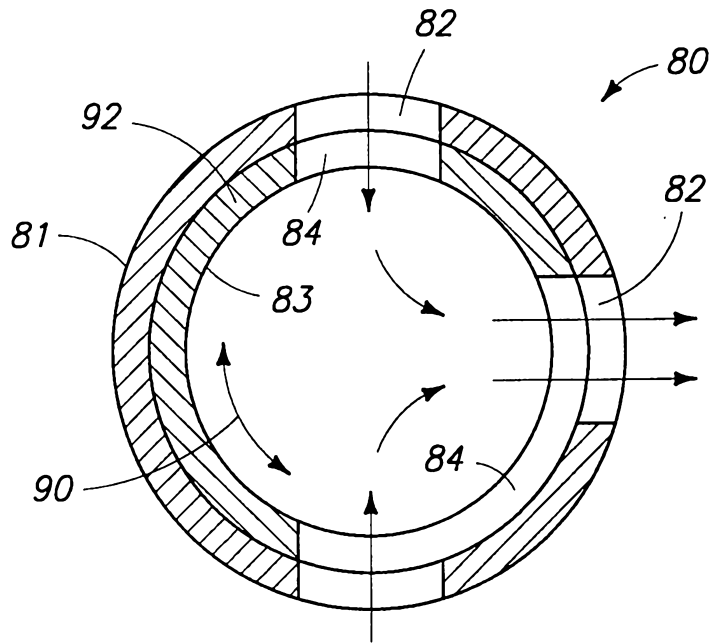

FIG. 7A

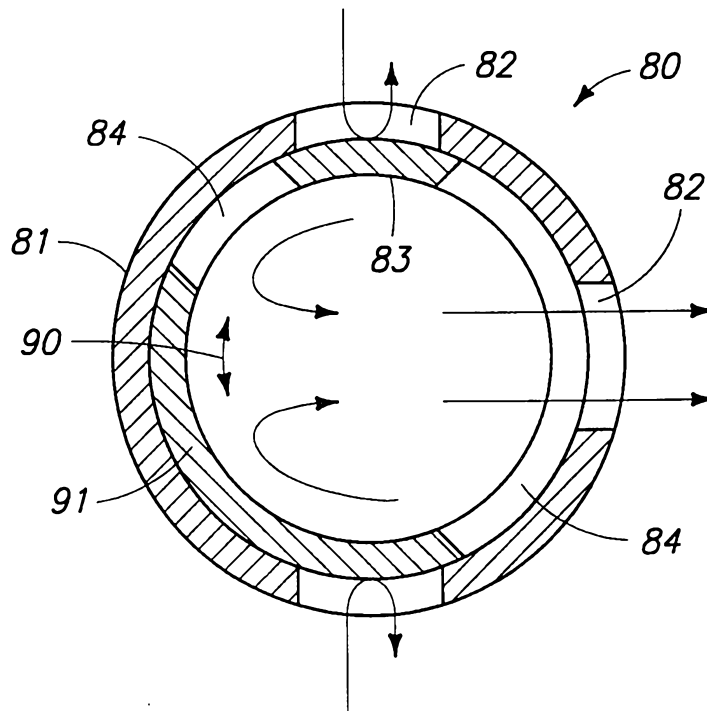

FIG. 7B

8/27

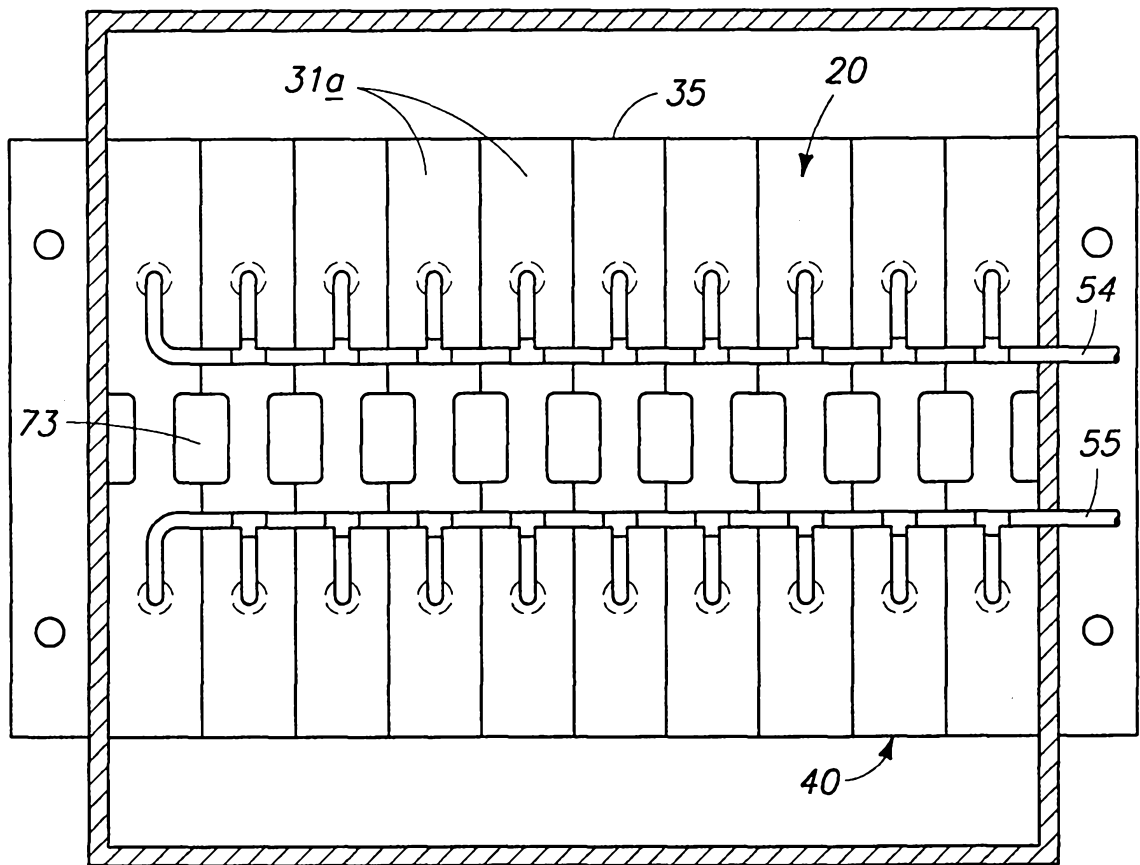
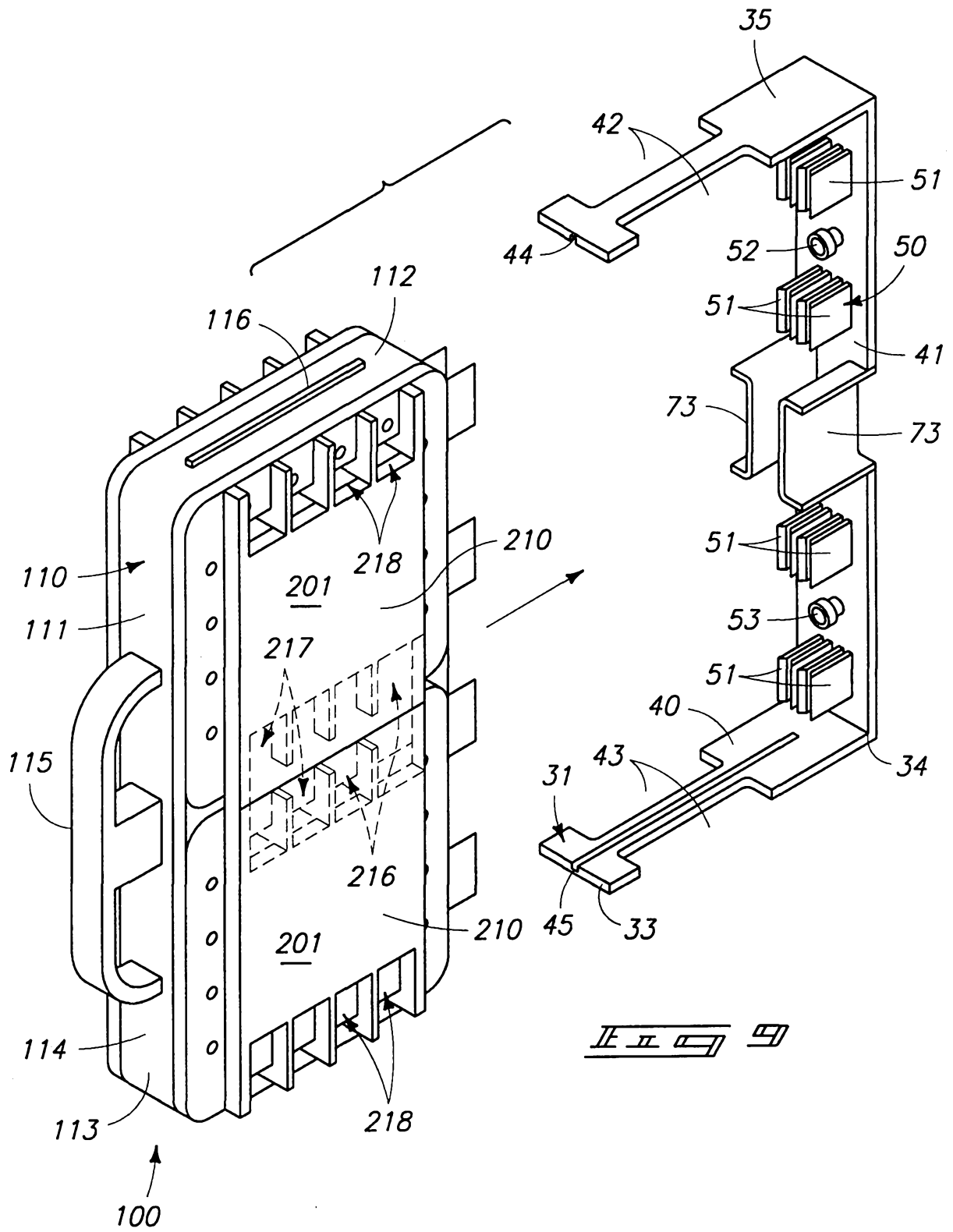
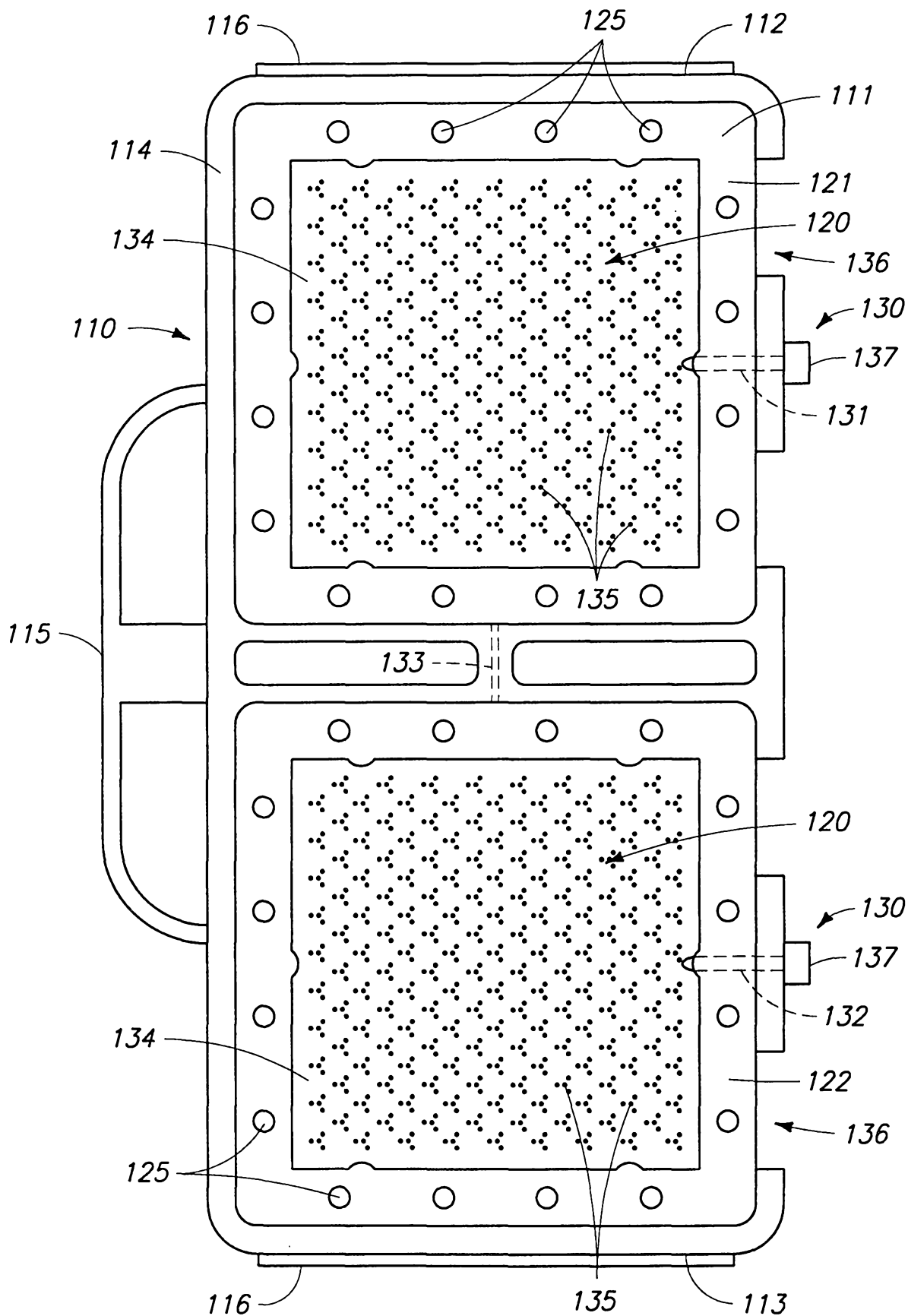

FIG. 8

9/27



10/27



11/27

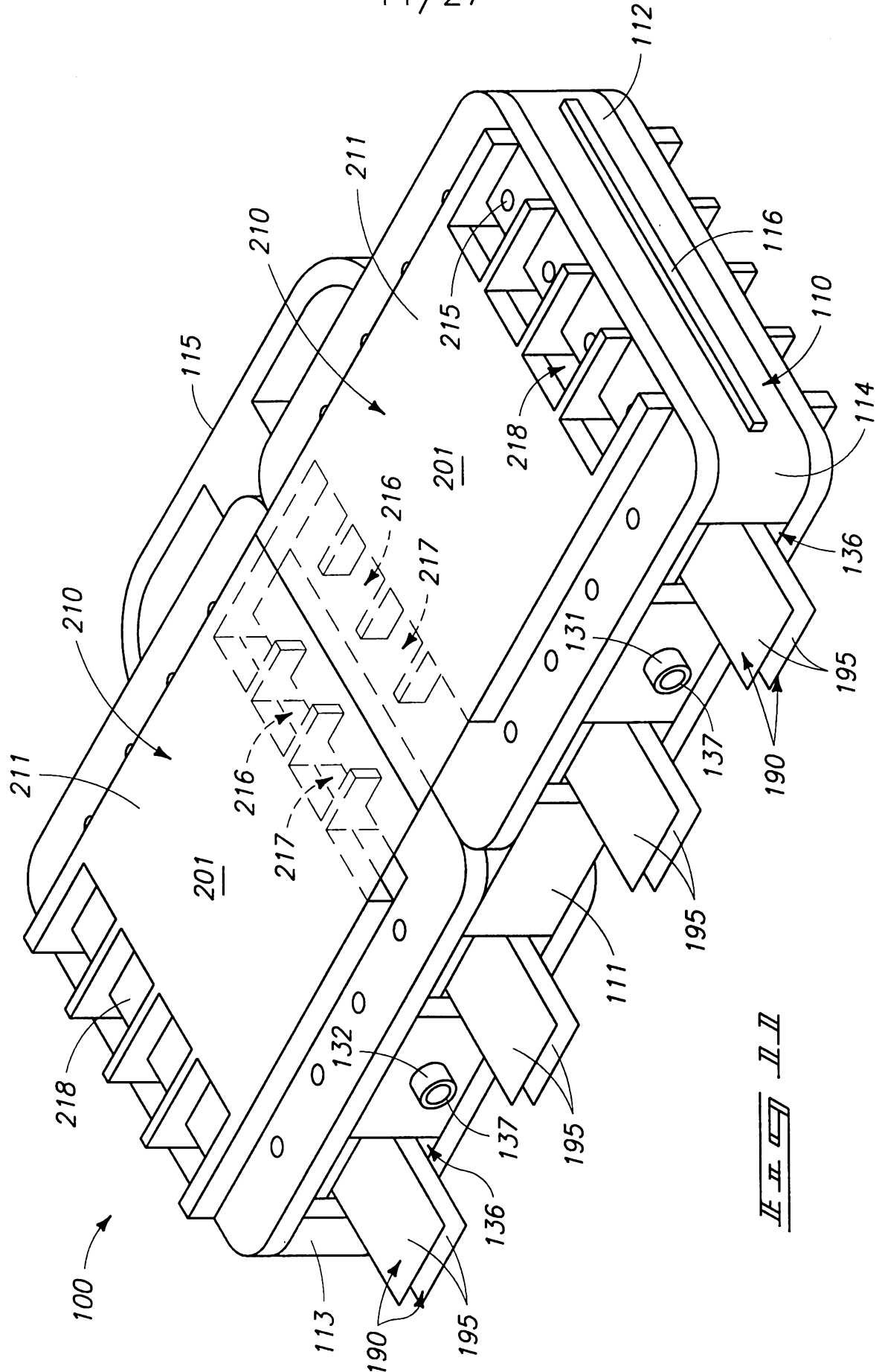

II II

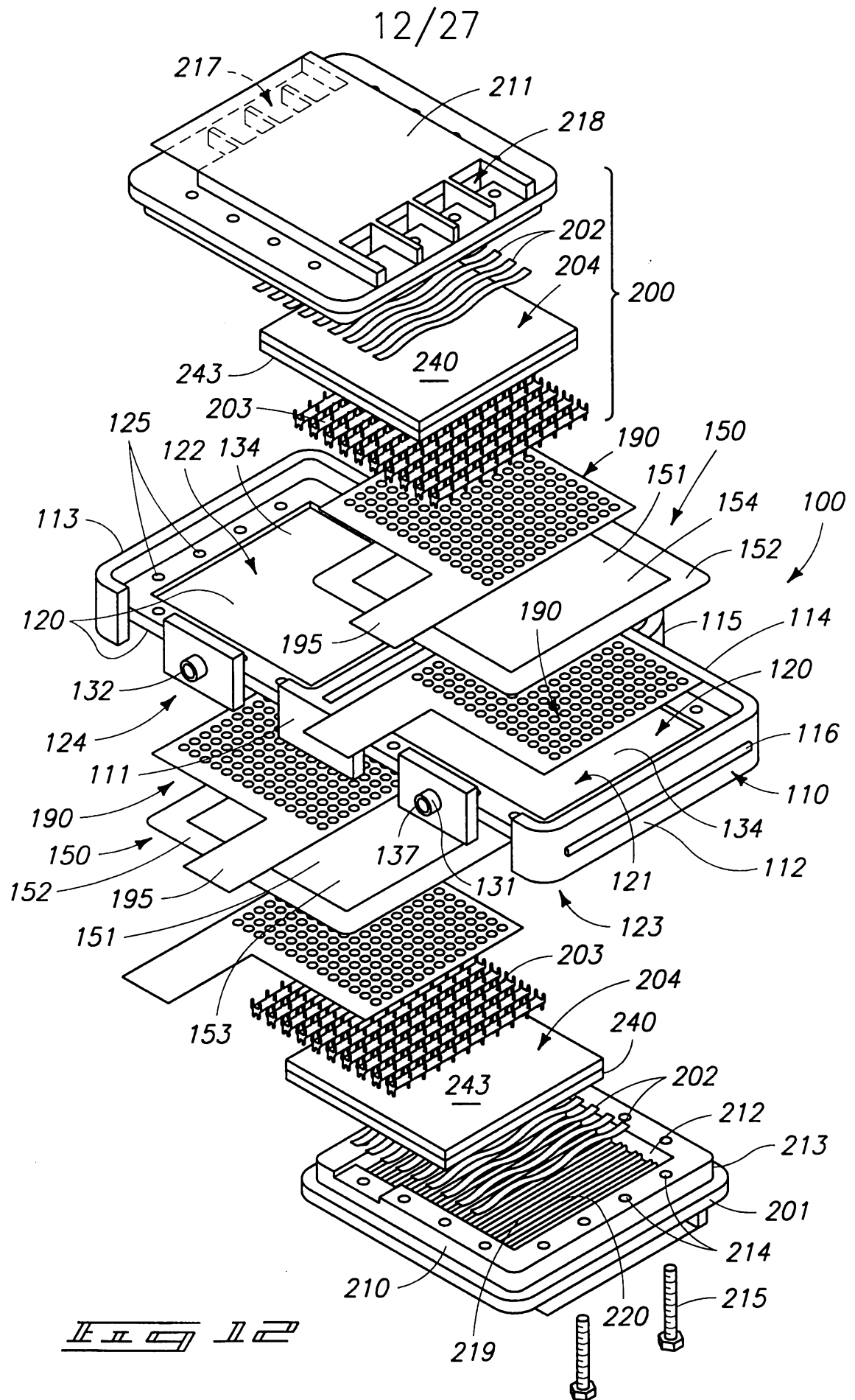



13/27

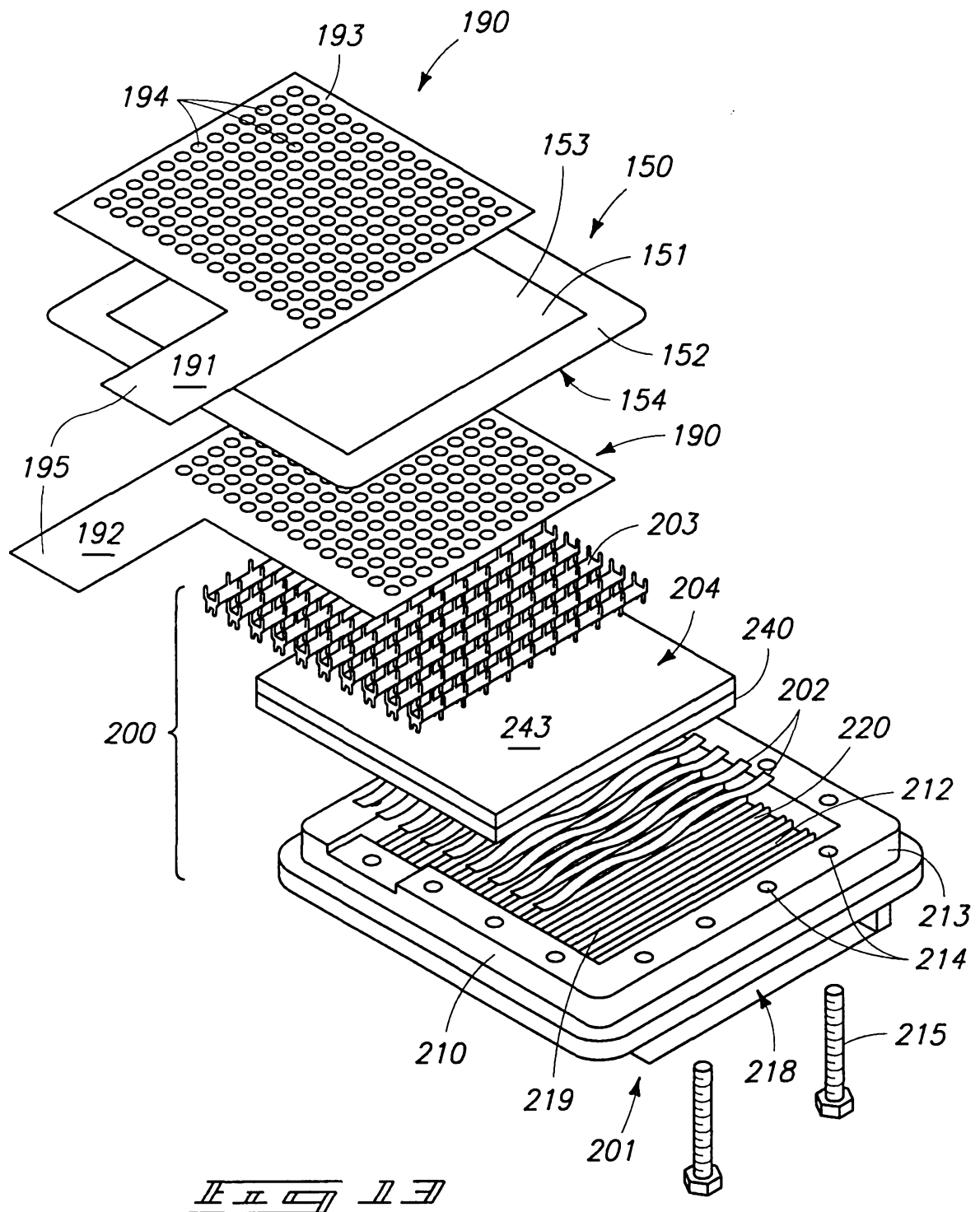

14/27

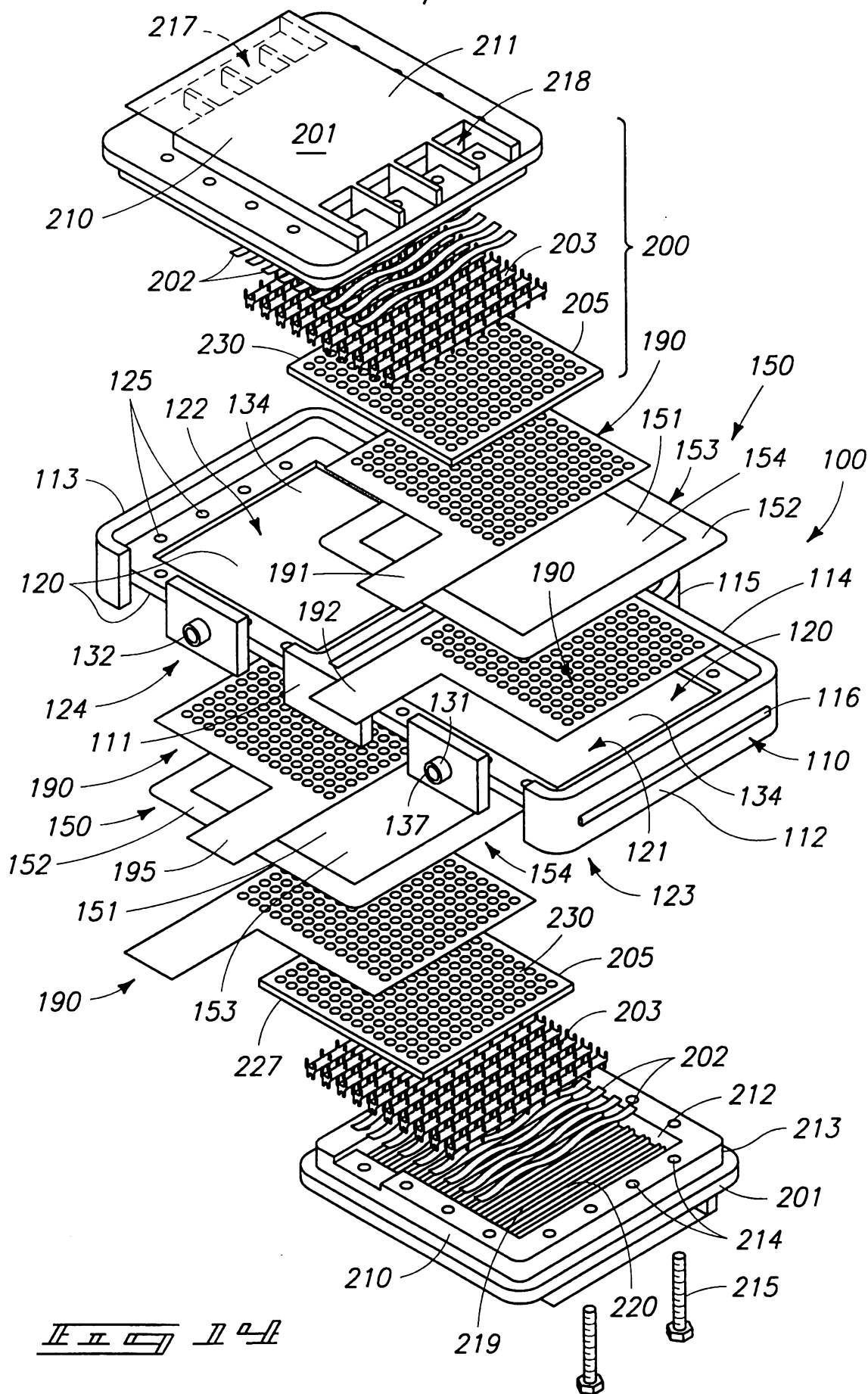

15/27

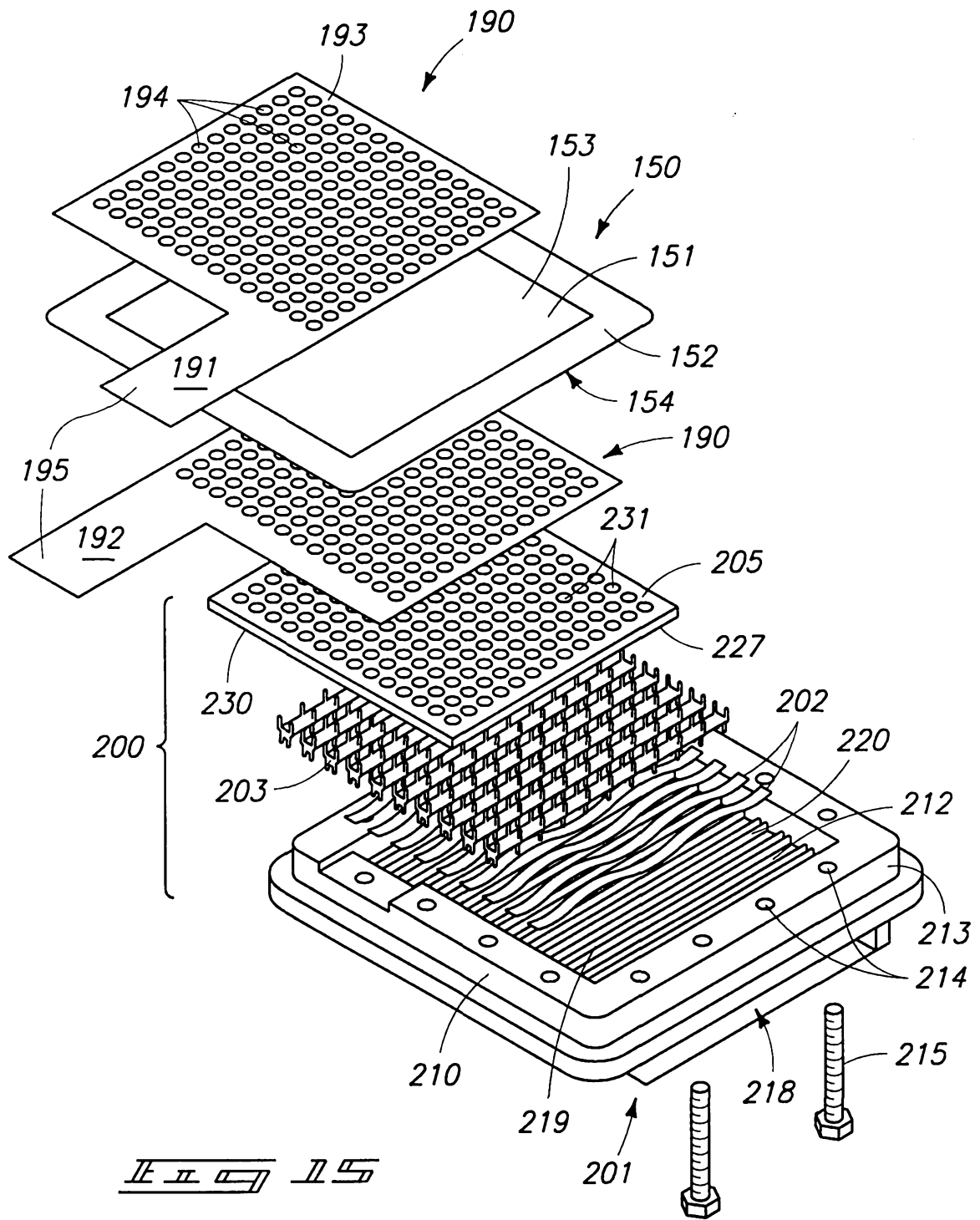

16/27

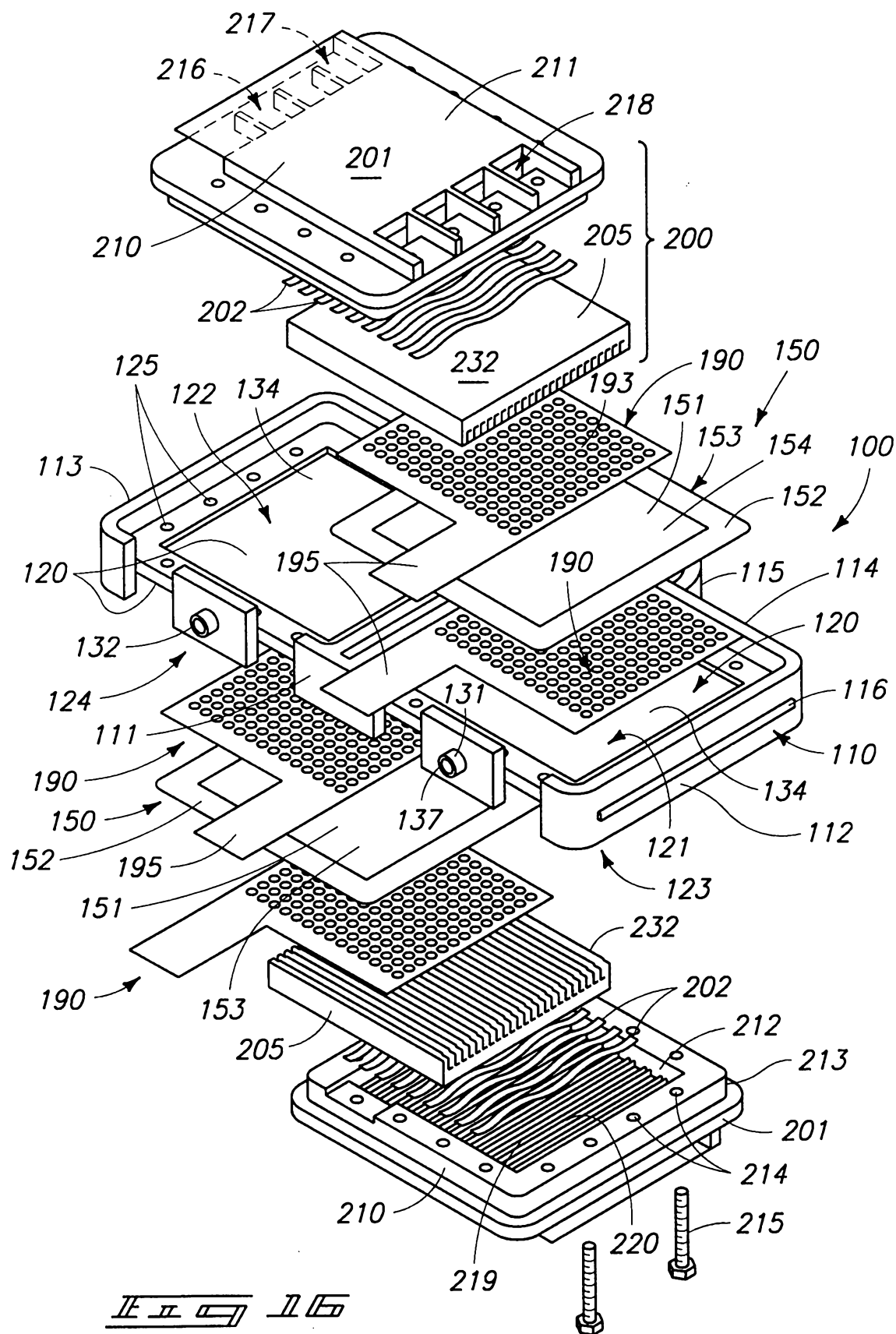

17/27

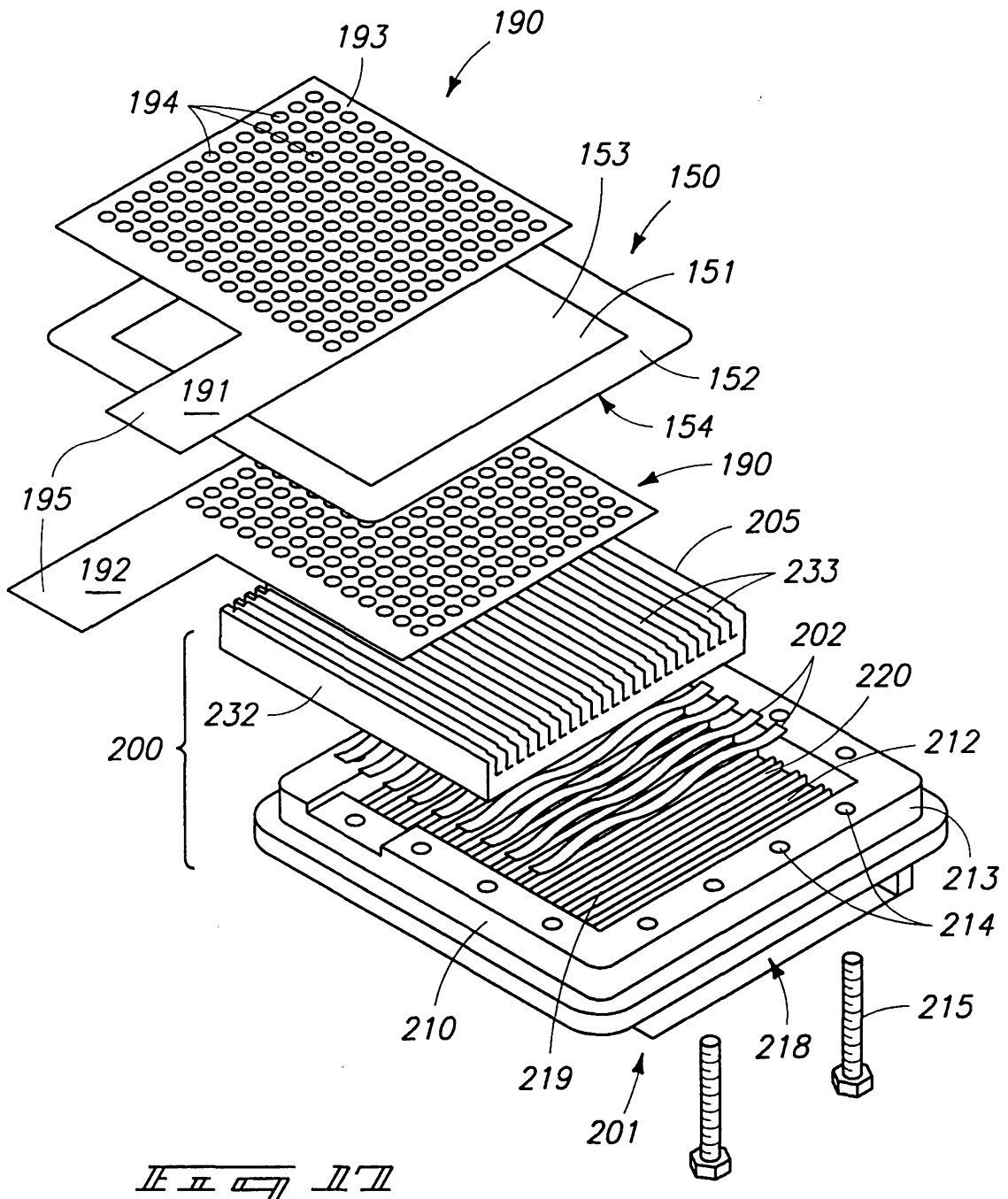

18/27

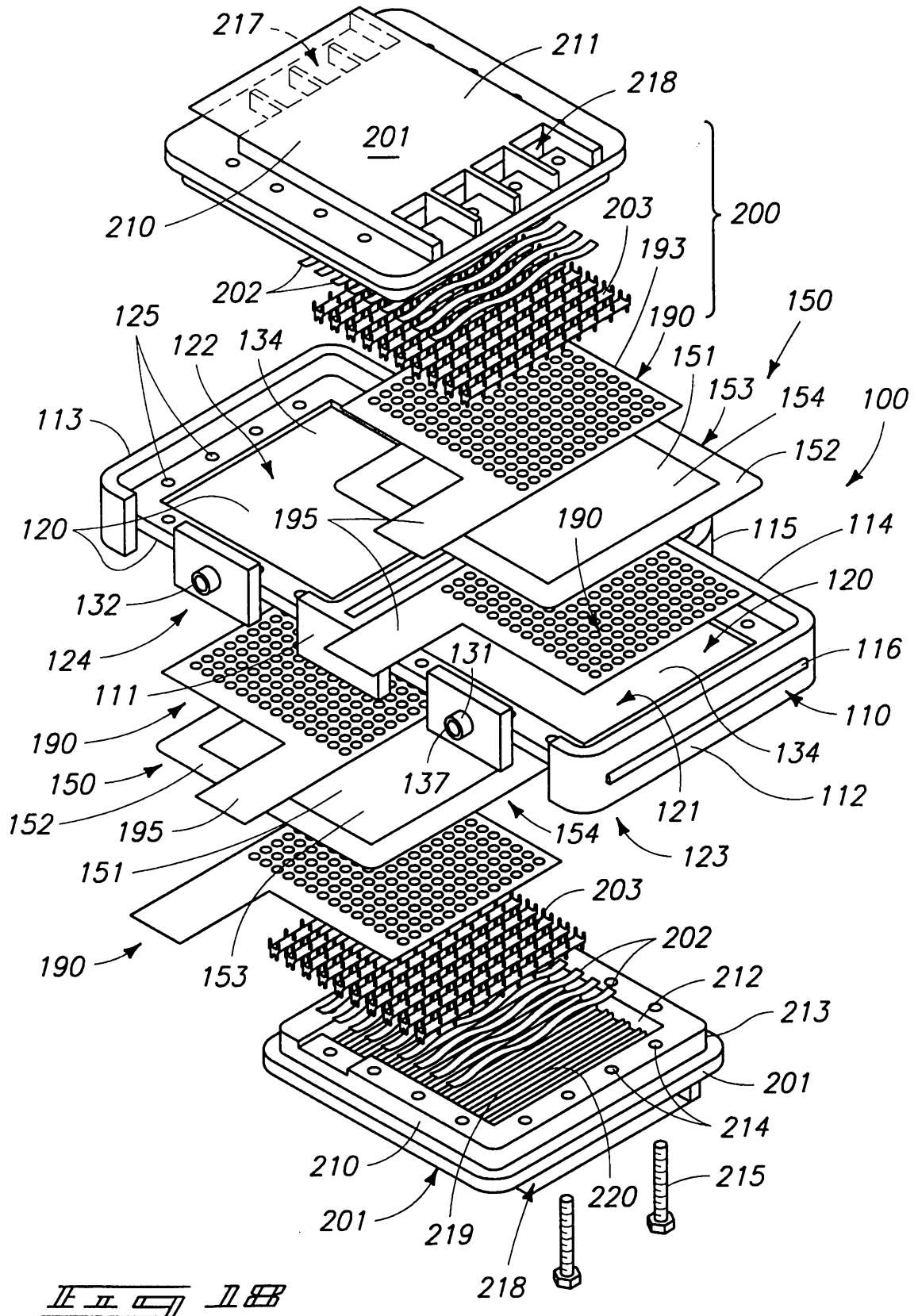

19/27

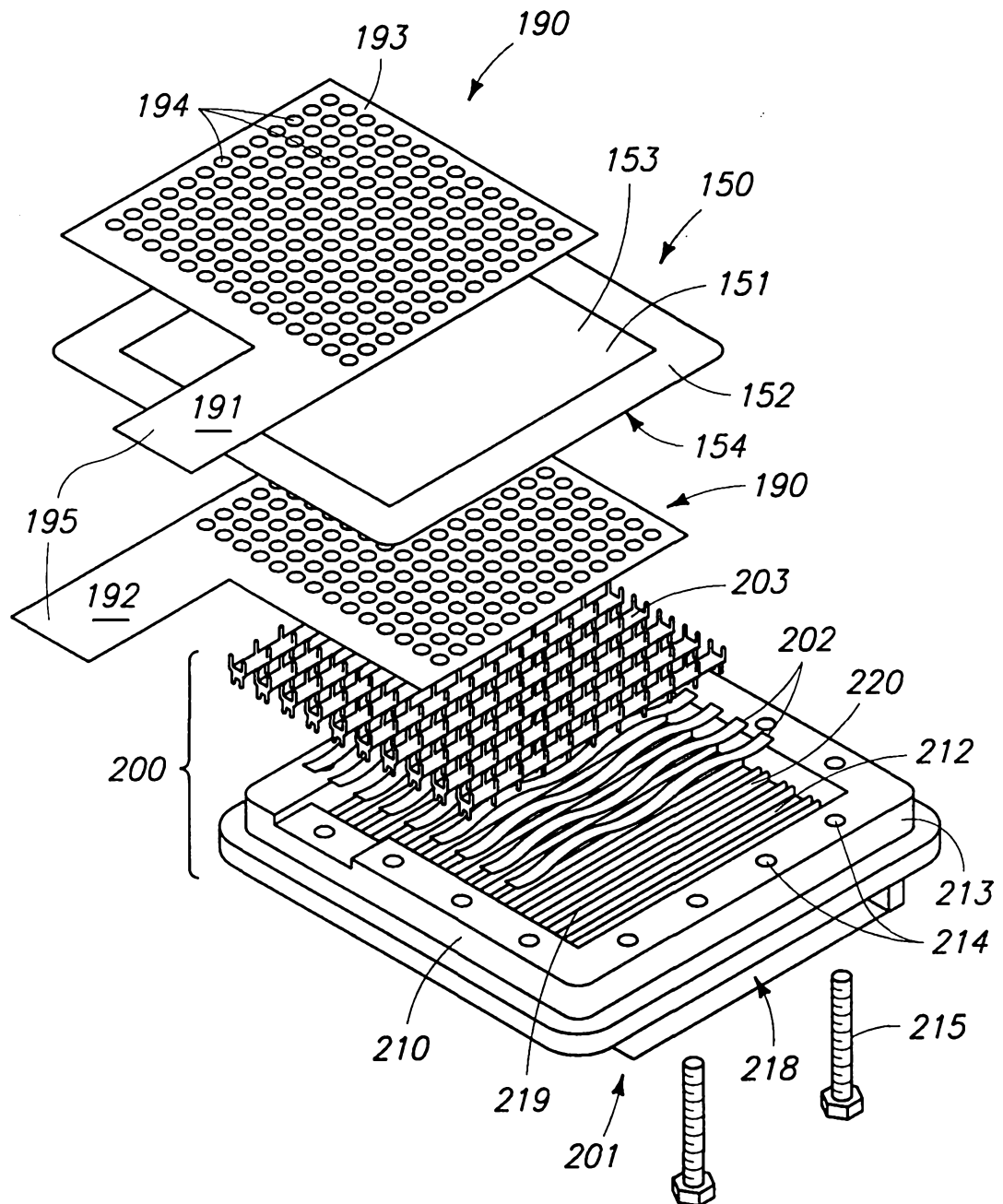

FIG. 19

20/27

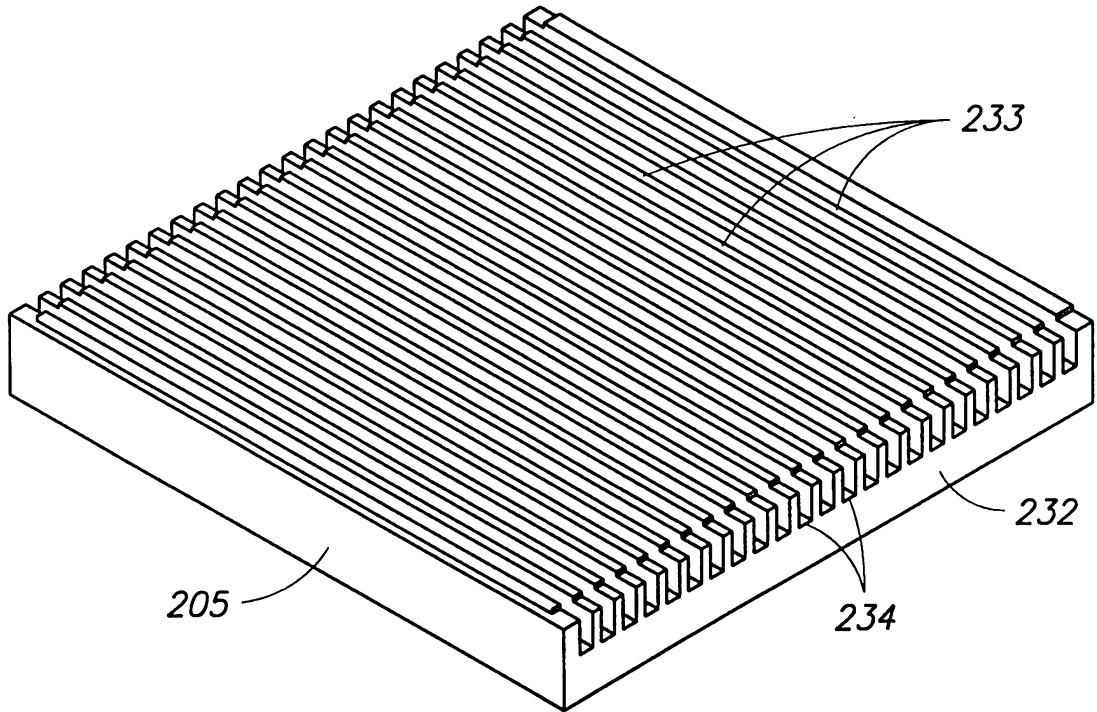

FIG 20

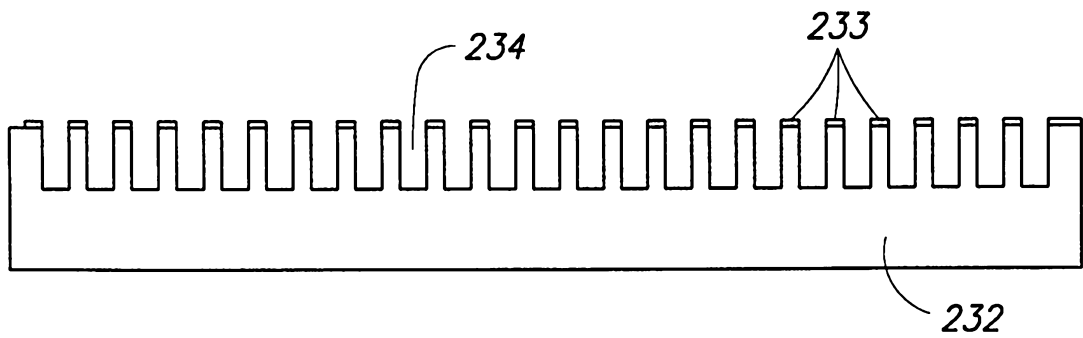
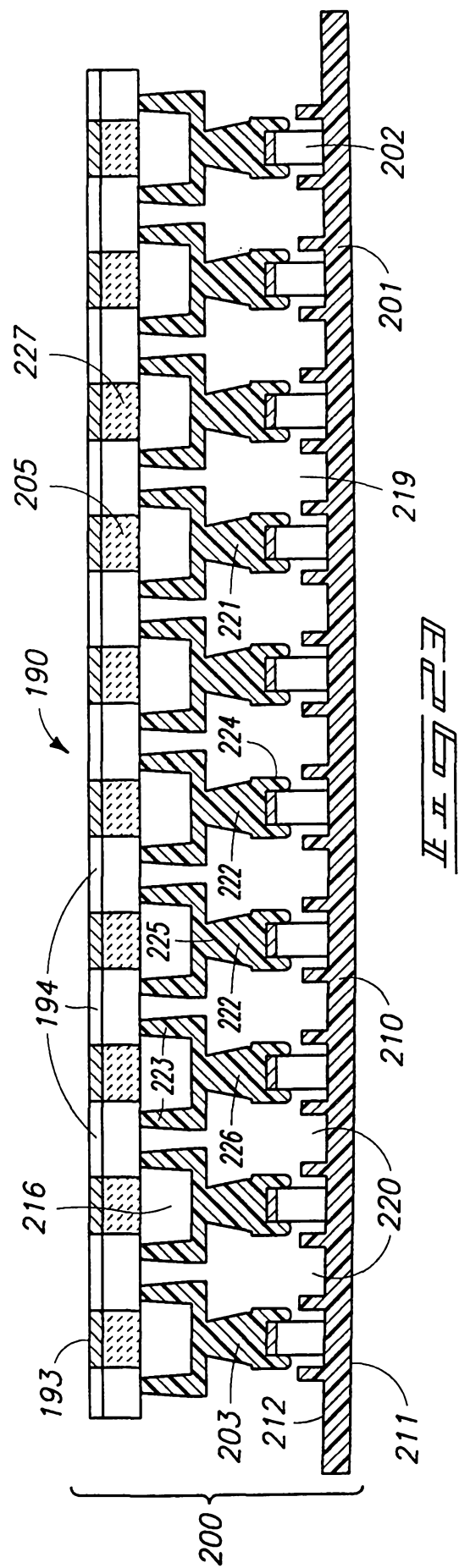
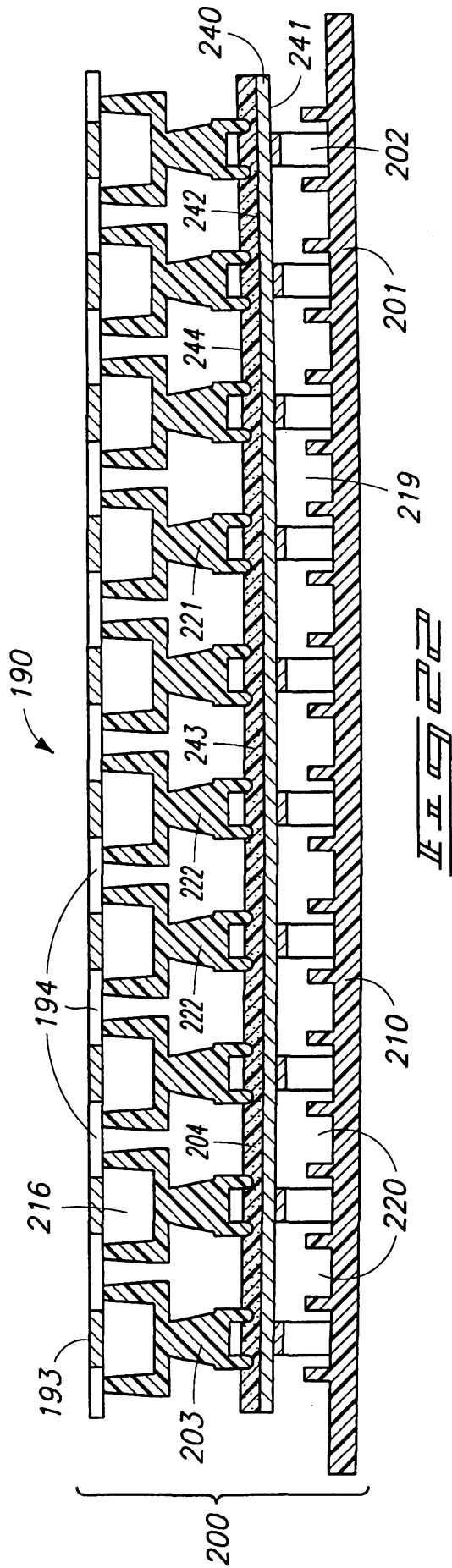
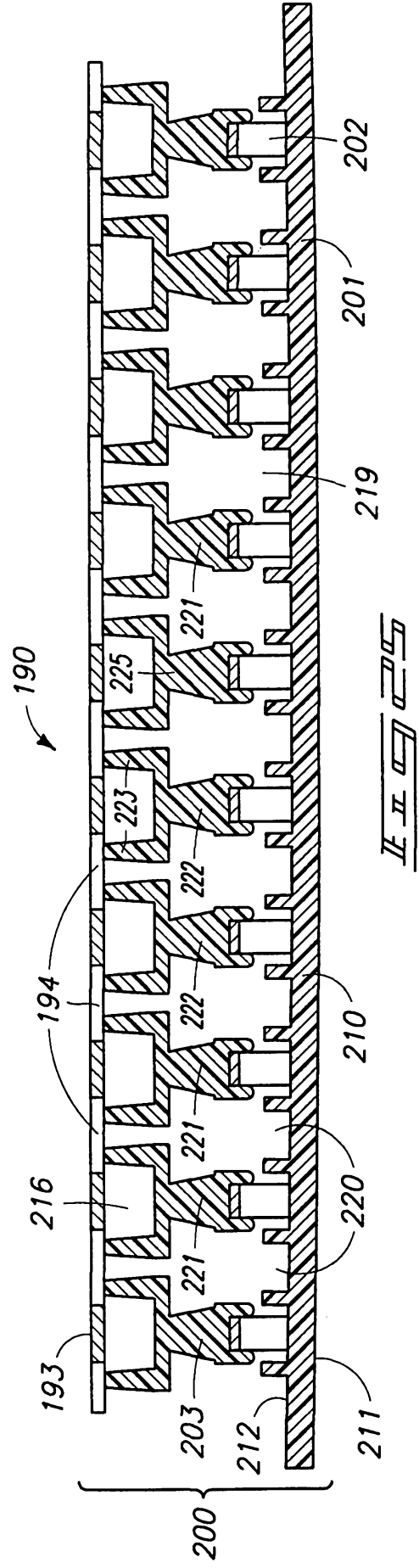
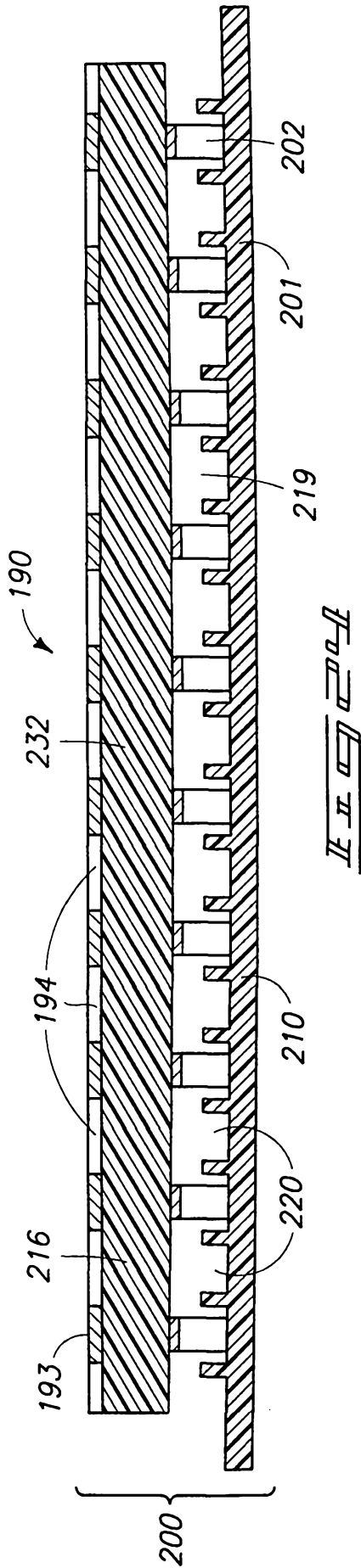

FIG 21







23/27

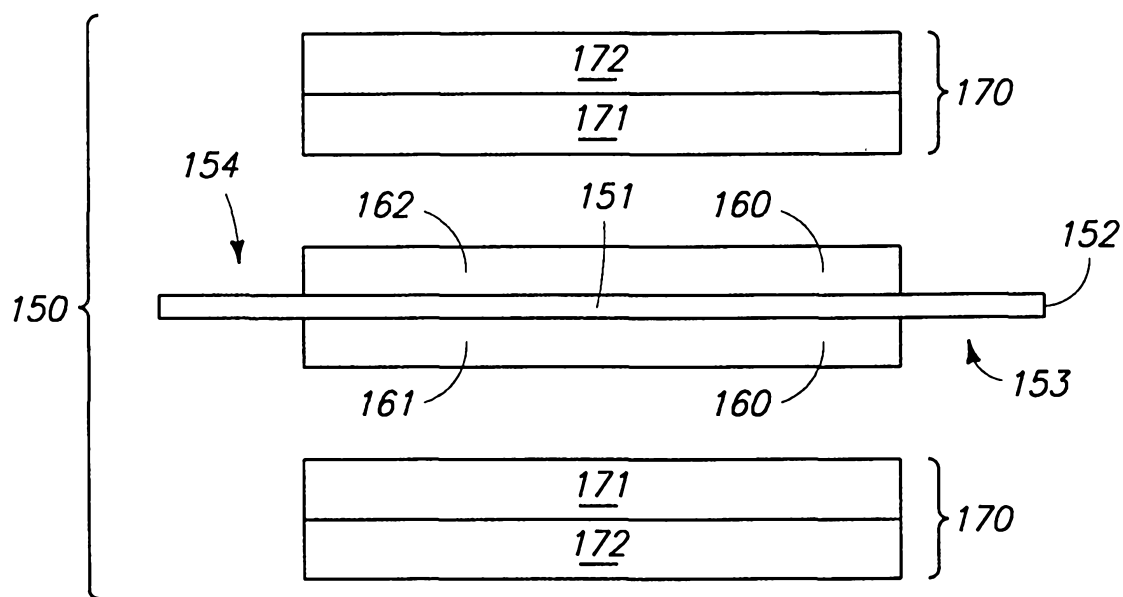

FIG. 23

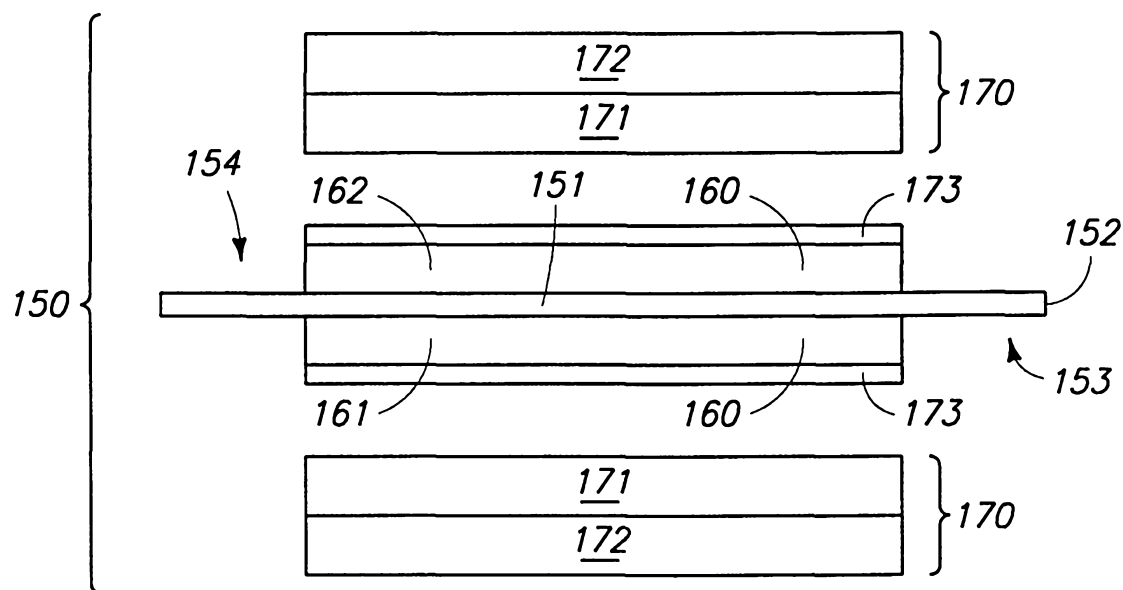
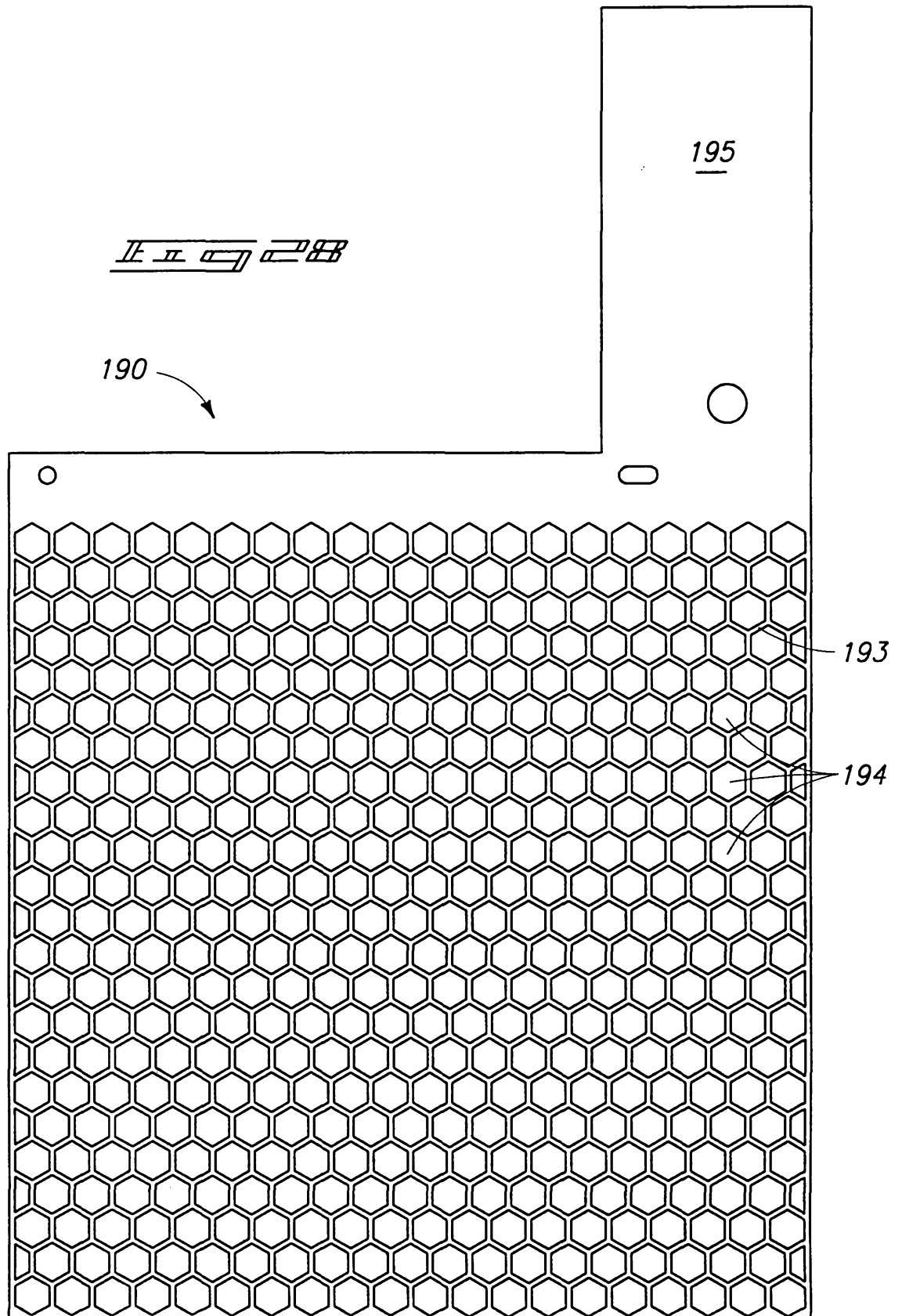
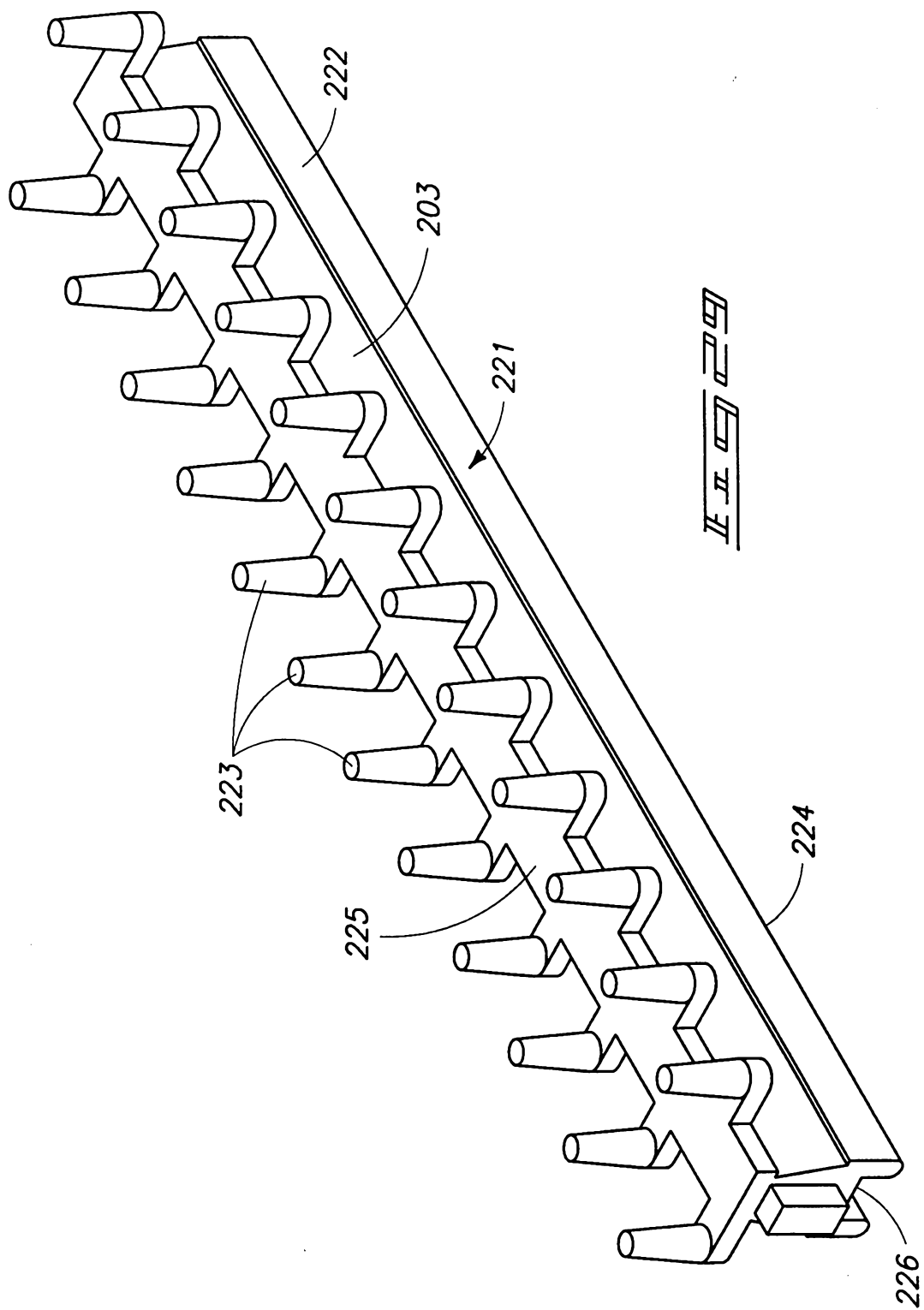

FIG. 24

24/27





26/27

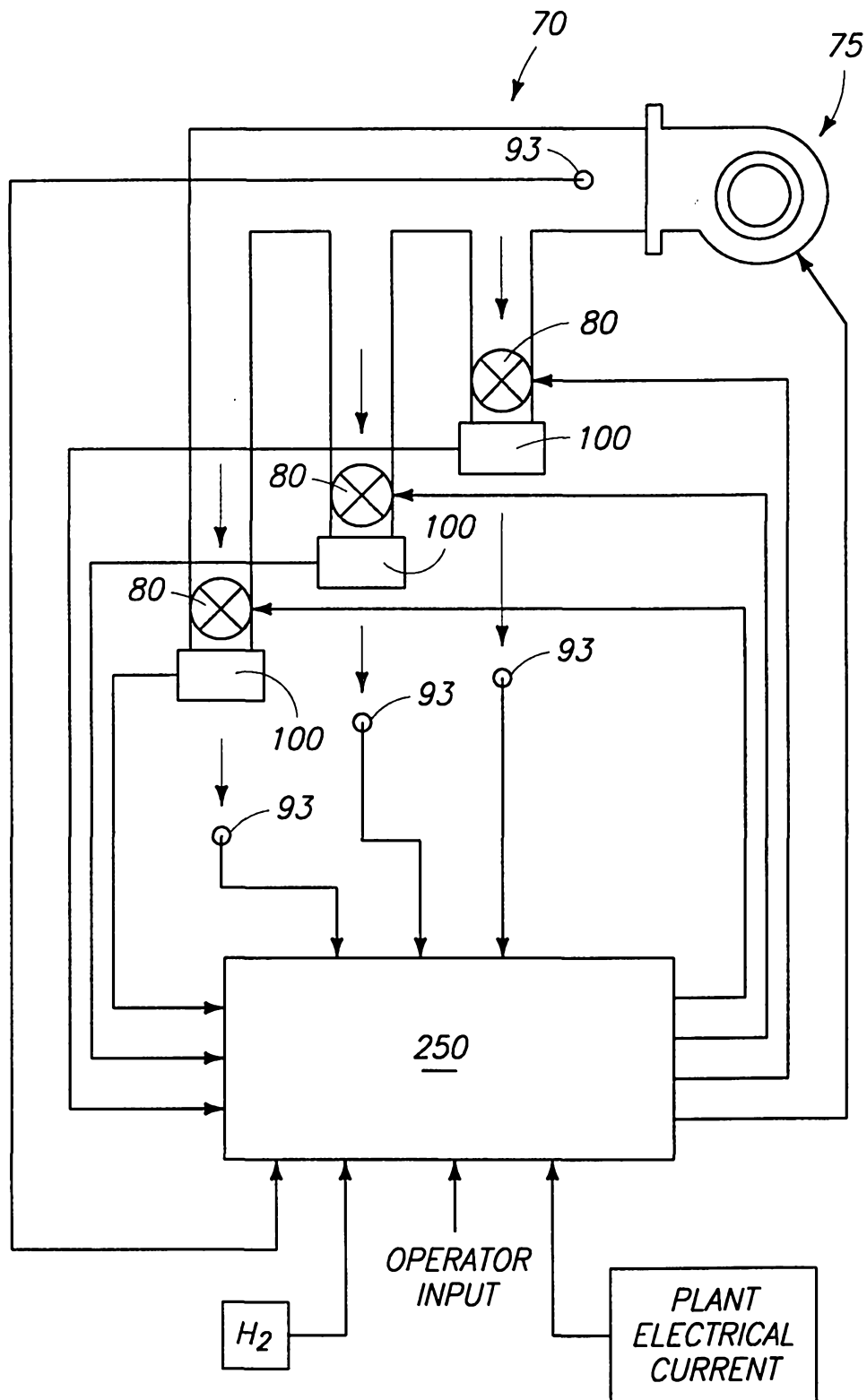

27/27

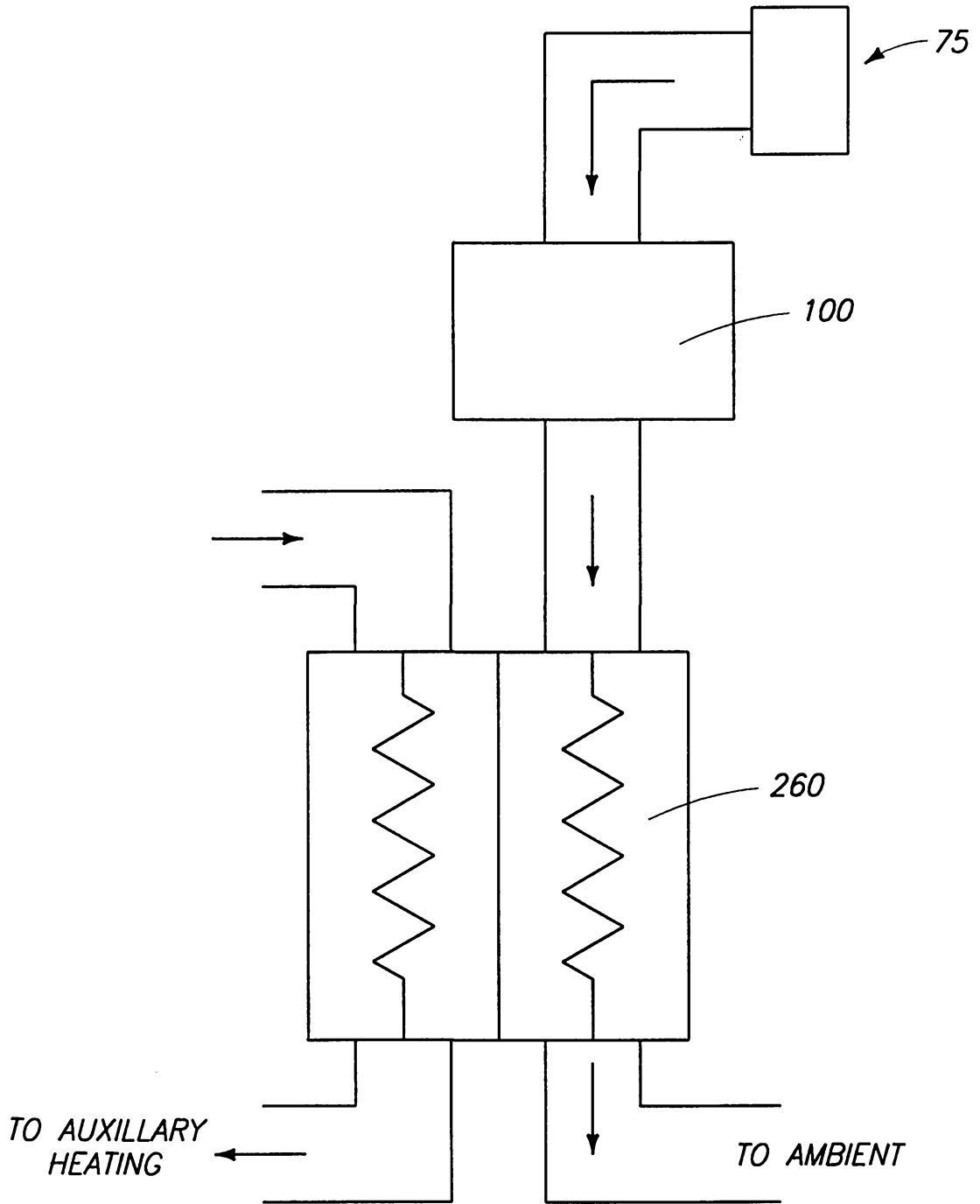

FIG. 27