

(No Model.)

F. McMAHON.

CAR COUPLING.

No. 369,949.

Patented Sept. 13, 1887.

Fig. 10.

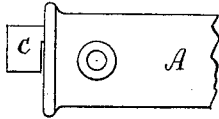

Fig. 1.

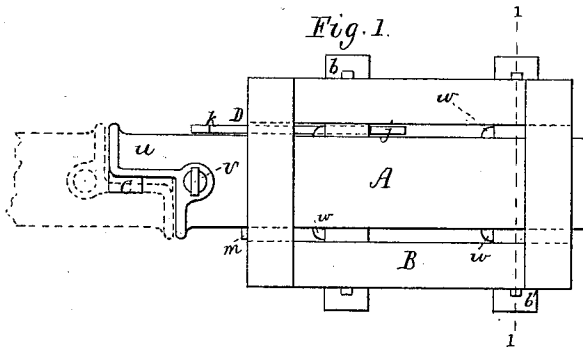

Fig. 2.

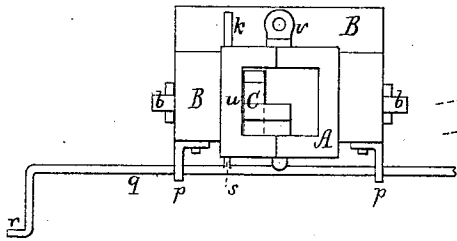

Fig. 3.

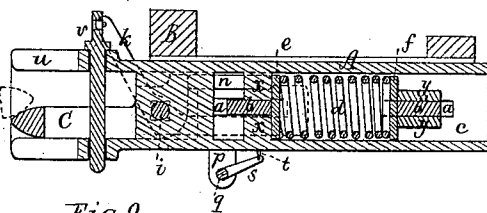

Fig. 9.

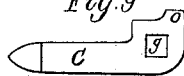

Fig. 4.

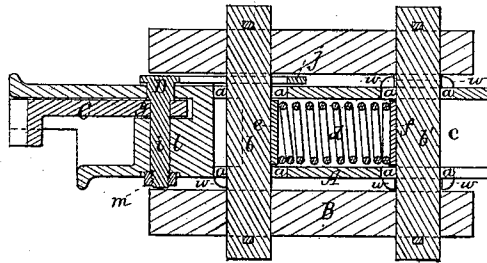

Fig. 5.

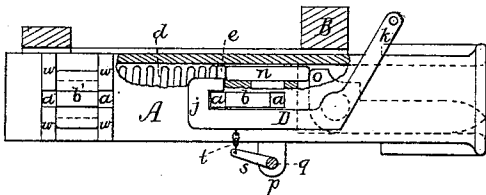

Fig. 6.

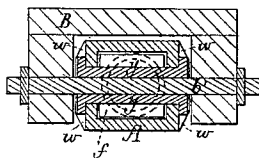

Fig. 7.

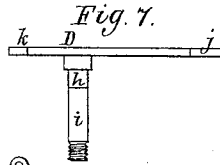
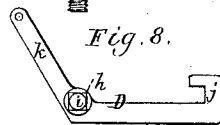

Fig. 8.



Witnesses:
John H. Preston
John S. and Wayne

Inventor:
Francis McMahon
by *Singleton & Piper* attys

UNITED STATES PATENT OFFICE.

FRANCIS McMAHON, OF SOMERVILLE, MASSACHUSETTS.

CAR-COUPLING.

SPECIFICATION forming part of Letters Patent No. 369,949, dated September 13, 1887.

Application filed July 14, 1887. Serial No. 244,276. (No model.)

To all whom it may concern:

Be it known that I, FRANCIS McMAHON, of Somerville, in the county of Middlesex and Commonwealth of Massachusetts, have invented a new and useful Improvement in Railway - Car Couplers; and I do hereby declare the same to be described in the following specification and represented in the accompanying drawings, of which—

10 Figure 1 is a top view, Fig. 2 an end elevation, Fig. 3 a longitudinal and median section, Fig. 4 a horizontal section, and Fig. 5 a side elevation, of a railway-car coupler provided with my invention, a portion of the draw-
15 bar being broken away in the latter figure to show the bar *n* in its relation to the coupling-hook and spring. Fig. 6 is a transverse section on line 1 1, Fig. 1. Fig. 7 is a top view, and Fig. 8 a side view, of the coupling-hook
20 actuator. Fig. 9 is a side view of the coupling-hook. Fig. 10 is a view of the draw-bar without the notch shown in its head in the other figures.

In the drawings, A denotes the draw-bar, 25 which is provided in its sides with slots *a*, to receive two bars, *b b'*, secured in the frame B, fastened to the bottom of the car-body. The slots *a* have a length greater than the width of the bars *b b'*, and are arranged in relation
30 to each other as shown, to allow the draw-bar to move on them either forward or backward in a longitudinal direction when necessary. In a chamber, *c*, in the draw-bar, and between the said bars *b b'*, (see Figs. 3 and 4,) is a
35 spring, *d*, arranged between two plates, *e f*, which are borne by the spring against the bars *b b'* when force is exerted on the draw-bar in longitudinal directions. The plate *e* also bears
40 against an abutment, *x*, formed in the draw-bar, as shown, and the plate *f* against two removable abutments, *y y*, arranged therein, as
45 shown in Figs. 3 and 6, the same being to admit of the removal of the bars *b b'* from the frame B and the draw-bar, so that the latter can be separated from the car and have the
50 spring *d* and its plates *e f* still retained therein in their proper relations to each other.

The abutments *y y* are arranged one above and the other below the bar *b'*, as shown, and are provided on their ends with flanges, which
50 rest against the opposite sides of the draw-bar

and hold them securely transversely of the draw-bar. The said flanged ends also extend between lugs *w*, formed on the sides of the draw-bar, (see Fig. 5,) which together resist
55 any force exerted against the abutments *y* by the spring in a direction longitudinally of the draw-bar. The lugs also serve to keep the draw-bar in its due relation to its supporting-
60 frame.

Cis the coupling-hook, formed and arranged in the mouth of the draw-bar, as shown, it being provided in its shank with a prismatic eye, *g*, to receive the prismatic part *h* of the
65 pivot *i* of an actuator, D, formed as seen in top view in Fig. 7 and in side view in Fig. 8. The actuator is provided with a hook, *j*, and an arm, *k*, and is pivoted in the draw-bar, as shown at *l*, and is held in connection with the
70 draw-bar by a nut, *m*, screwed on the end of its pivot. (See Fig. 4.) The coupling-hook rests on the bottom of the mouth of the draw-bar, and is held down thereupon by a short
75 bar, *n*, which bears against the tail *o* of the coupling-hook and the plate *e*, against which the spring *d* bears. By pulling on a cord or
80 chain attached to the arm *k* of the actuator and extending up to the platform or to the top of the car, the coupling-hook can be raised to free itself from the hook of its fellow coupler,
85 in order to uncouple one car from another.

To operate the coupling-hook from the side of the car, I apply to the frame B two brackets, *p p*, to support a shaft, *q*, each end of
85 which I provide with a handle or crank, *r*. An arm, *s*, secured to said shaft *q*, is arranged under the actuator and connected therewith by a short chain or link, *t*. By turning the shaft
90 *q* by means of the handle or crank *r* the coupling-hook can be raised to release it from its fellow coupler, as may be required.

When two cars provided with the above-described coupler are to be coupled, as they come together, the point of one coupling-hook will
95 strike and ride up over its fellow, and as its hook passes the hook of its fellow it will be forced down past the same to the bottom of the mouth of the draw-bar by its spring *d*, plate *e*, bar *n* acting against the tail *o* of its hook.
100 As the draw-bars press together they will slide on the bars *b b'*, and the plate *f* in each will be borne against its bar *b'* and resist said

pressure. When force is applied to the couplers to draw them apart—as, for instance, when the train is in motion—the draw-bars will slide on the bars *b b'* in the opposite direction from that above described, and in so moving will carry the hook *j* of the actuator over the bar *b*, and thereby lock the coupling-hooks, so that they cannot be released from each other until freed from the force applied to them.

The head of the draw-bar is provided with a guard, *u*, to protect the coupling-hook from injury when in use with other couplers of different construction. It is also provided with the ordinary coupling-pin, as shown at *v*, to admit of it being used with a coupler having the ordinary coupling-link.

When the coupler above described is to be used with couplers of like construction exclusively, I form the head without the guard *u*, as seen in Fig. 10.

Having described my invention, what I claim is—

1. The combination of the frame B and the bars *b b'*, having the draw-bar applied to them, as shown, the coupling-hook C, arranged in the draw-bar and connected therewith and with the actuator D, as described, the draw-bar having a chamber, *c*, to receive the spring *d* and plates *e f*, and being also provided with the abutments *x* and *y y* and the bar *n*, all being arranged and to operate substantially as described.

2. The combination of the draw-bar, supported as described, the coupling-hook C, its

actuator D, the bar *n*, arranged in said draw-bar and to operate with the coupling-hook and spring *d*, essentially as set forth.

3. The actuator D, provided with the arm *k*, hook *j*, and pivot *i*, having the prismatic part *h* to enter the eye of the coupling-hook, as set forth.

4. The actuator D, provided with the arm *k*, hook *j*, and pivot *i*, provided with the prismatic part *h* to enter the eye of the coupling-hook, in combination with the shaft *g*, supported as shown and provided with the cranks *r* and arm *s*, and link or chain *t*, for actuating said coupling-hook, as explained.

5. The coupling-hook provided with the tail *o* and prismatic eye *g*, as explained.

6. The draw-bar provided with the guard *u*, and having slots *a* in its sides and lugs *w*, as shown, and having in it the chamber *c*, abutment *x*, and recesses for the bar *n* and coupling-hook, and a bearing for the actuator, in combination with the coupling-hook C, its actuator D, bar *n*, plates *e* and *f*, spring *d*, and abutments *y y*, substantially as shown and described.

7. The draw-bar having its head formed as shown in Fig. 10, and having the slot *a* and lugs *w*, chamber *c*, abutments *x y y*, spring *d*, plates *e f*, bar *n*, coupling-hook C, and actuator D, all essentially as set forth.

FRANCIS McMAHON.

Witnesses:

S. N. PIPER,

R. B. TORREY.