



AU9514651

(12) PATENT ABRIDGMENT (11) Document No. AU-B-14651/95
(19) AUSTRALIAN PATENT OFFICE (10) Acceptance No. 697467

- (54) Title
A COUPLING ARRANGEMENT BETWEEN A MULTI-MODE LIGHT SOURCE AND AN OPTICAL FIBER THROUGH AN INTERMEDIATE OPTICAL FIBER LENGTH
- International Patent Classification(s)
(51)⁶ **H01S 003/06 G02B 006/28 G02B 006/42**
- (21) Application No. : **14651/95** (22) Application Date : **28.12.94**
- (87) PCT Publication Number : **WO96/20519**
- (43) Publication Date : **19.07.96**
- (44) Publication Date of Accepted Application : **08.10.98**
- (71) Applicant(s)
ITALTEL S.P.A.; IRE-POLUS CO.
- (72) Inventor(s)
VALENTIN P GAPONTSEV; IGOR SAMARTSEV
- (74) Attorney or Agent
SPRUSON & FERGUSON , GPO Box 3898, SYDNEY NSW 2001
- (56) Prior Art Documents
EP 136871
EP 180861
JP 60-107007
- (57) Claim

1. A coupling arrangement for non-axial transfer of light power between a multi-mode light source, having a substantially circular emission with a divergence angle α_s , and a first multi-mode optical fiber with a cross section A_c , through a length of a second multi-mode optical fiber having an end with cross section area A_f coupled with said light source and one portion fused to said first multi-mode optical fiber, wherein said second multi-mode optical fiber has a progressively tapered portion and is fused to said first multi-mode optical fiber at a region of the progressively tapered portion, and in that the relationship between the acceptance angle α_f of the second multi-mode optical fiber and the emission angle α_s of the light source is expressed by:

$$\alpha_f = k \times \alpha_s$$

where k is a positive constant greater than 1.





II

<p>(51) International Patent Classification ⁶ : H01S 3/06, G02B 6/28, 6/42</p>	<p>A1</p>	<p>(11) International Publication Number: WO 96/20519 (43) International Publication Date: 4 July 1996 (04.07.96)</p>
<p>(21) International Application Number: PCT/IT94/00218 (22) International Filing Date: 28 December 1994 (28.12.94)</p> <p>(71) Applicants (for all designated States except US): ITALTEL SOCIETA' ITALIANA TELECOMUNICAZIONI S.P.A. [IT/IT]; Piazzale Zavattari, 12, I-20149 Milano (IT). IREPOLUS CO. [RU/RU]; Vvedenskogo Sq. 1, Fryazino, Moscow 141120 (RU).</p> <p>(72) Inventors; and (75) Inventors/Applicants (for US only): GAPONTSEV, Valentin P. [RU/RU]; Apartment 320, Mira Street Building 12, Fryazino, Moscow 141120 (RU). SAMARTSEV, Igor [RU/RU]; Apartment 404, Lenin Street Building 47, Fryazino, Moscow 141120 (RU).</p> <p>(74) Agent: GIUSTINI, Delio; Italtel Società Italiana Telecomunicazioni S.p.A., P.O. Box 10, I-20019 Settimo Milanese (IT).</p>		<p>(81) Designated States: AU, CA, JP, RU, US, European patent (AT, BE, CH, DE, DK, ES, FR, GB, GR, IE, IT, LU, MC, NL, PT, SE).</p> <p>Published With international search report.</p>

(54) Title: A COUPLING ARRANGEMENT BETWEEN A MULTI-MODE LIGHT SOURCE AND AN OPTICAL FIBER THROUGH AN INTERMEDIATE OPTICAL FIBER LENGTH

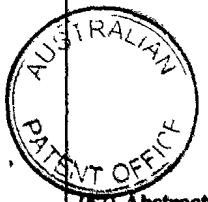
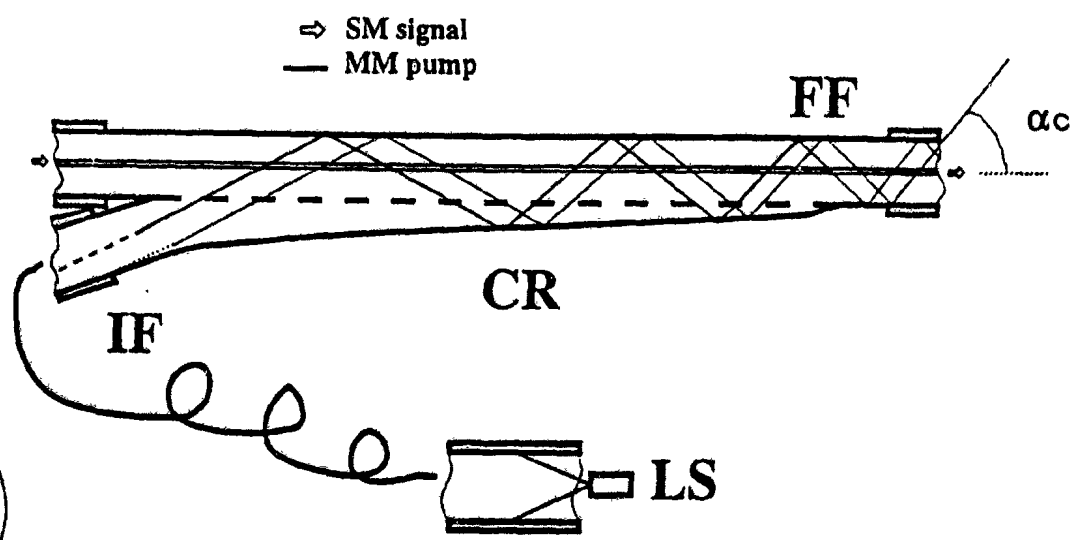

(57) Abstract

A coupling arrangement for non-axial transfer of light power between a multi-mode light source (LS), having a substantially circular emission with a divergence angle α_s , and a multi-mode optical fiber (FF) with a cross section A_c , through a length of an intermediate feeding multi-mode optical fiber (IF) having an end with cross section area A_f coupled with said light source (LS) and one portion fused to said optical fiber (FF). Said feeding fiber (IF) has a progressively tapered portion and is fused to said multi-mode optical fiber (FF) at a region of the tapered fiber, and in that the relationship between the acceptance angle α_f of the feeding fiber (IF) and the emission angle α_s of the light source (LS) is expressed by: $\alpha_f = k \alpha_s$ where k is a positive constant greater than 1.

A COUPLING ARRANGEMENT BETWEEN A MULTI-MODE LIGHT SOURCE AND
AN OPTICAL FIBER THROUGH AN INTERMEDIATE OPTICAL FIBER LENGTH

5 Field of the invention

This invention relates in general to the coupling or transfer of light power between a light source and an optical guide, and more particularly to arrangements for improving the energy transfer efficiency between a light
10 source and an optical fiber through an intermediate optical fiber length or pigtail, when a coaxial feeding to the final optical fiber is either undesired or impossible.

In a particular and preferred embodiment that will be illustrated in detail, the system acts as a part of an
15 optical amplifier. In this case the light source includes a multi-mode semiconductor laser diode - or an array of such diodes - emitting around a certain wavelength and acting as a pump source, and the final optical guide includes a single-mode core carrying a travelling signal (single-mode
20 radiation of a wavelength different from the pumping one) to be amplified.

In the above mentioned preferred embodiment the invention aims in particular to realize a highly efficient coupling between a multi-mode optical fiber pigtail and a so called
25 single-mode double-cladding (SM-DC) optical fiber, although the invention is not to be considered restricted to such a preferred application. As Single-Mode Double-Cladding (SM-DC) optical fiber it is meant a fiber that includes an inner (Single-Mode) core with a diameter of few microns, a
30 first cladding (or multi-mode core), and a second cladding. Actually there are a number of situations in which a fiber needs to receive light from one or more sources in a non-coaxial way, i.e. not along the longitudinal axis of the fed fiber. As an example, whenever it is requested to carry
35 two or more different radiations along a single guide (with the radiations being different in amplitude, wavelength,

signal pattern or code, and so on) an increase of the number of different sources is involved, which can be also of different kinds, and some kind of separation of the optical paths entering the final guide is required.

5 Furthermore a non coaxial coupling arrangement could be required in a fiber laser device in which the axial pumping would require a special mirror (with selected reflectivity) which should be transparent to the pump radiation, and with a high reflectivity at the lasing wavelength.

10 Another situation in which a non-coaxial feeding is requested is disclosed for example in US-A-5 170 458 concerning an optical amplifier obliquely receiving the pumping light.

There are known several arrangements for coupling a (additional) light source to an optical fiber that include one or more of the following coupling devices:

- a prism
- the insertion of an optical guide of whatever kind (integrated or with discrete elements)
- 20 - an intermediate optical fiber joined to the final fiber by means of a micro-optic coupler (i.e. a coupler adopting microlenses, or beam splitters, or other discrete microscopic devices)
- an intermediate optical fiber joined to the final 25 fiber by means of a fused-fiber coupler.

The above first three examples raise considerable alignment problems in terms of mechanical tolerances, that make their realization very expensive and critical from a technological point of view, in general producing a poor 30 coupling efficiency.

Usually, in telecommunication systems incorporating optical fiber amplifiers (OFAs), i.e. lengths of properly doped single-mode optical fiber serially connected in the communication route, these lengths of fiber are fed with 35 light from one or more single-mode laser diodes through suitable fused-fiber couplers, each of them being in turn

coupled with one or more laser diodes. Such (single-mode) couplers, formed by merging or fusing two or more pieces of fiber, can show a coupling efficiency as high as 90%. In coupling the laser chip to the pigtail an efficiency of
5 less than 50% is normally achieved. Due to the limited power obtainable from single mode diodes, high optical power is needed, the system has to include a large number of diodes, decreasing the reliability of the system as a whole.

10 In order to improve the saturated output power of the optical amplifier, without increasing the number of pump diodes involved, it has been suggested (see for example US-A- 4 829 529 to Kafka) to use a SM-DC optical fiber, activated by one or more diode arrays coupled by means of
15 bulk optics to the fiber end face.

The present invention concerns an arrangement which allows the use of multi-mode laser diode(s) or an array thereof coupled to the final fiber through an intermediate optical fiber and a fused-fiber coupler. This is advantageous since
20 multi-mode laser diodes are capable of reaching higher output power levels than single-mode diodes, and maintain good performance and reliability.

As it is known a multi-mode laser chip emits light through a narrow slit having a thickness in the order of 1 micron
25 and a width that can be of several tens of microns, with the light beam highly diverging in the transverse plane and moderately diverging in a plane parallel to the slit width. As an example, for laser diodes with 50 μm stripe width, in order to collect as much light as possible, a pigtail i.e.
30 a multimode fiber is usually adopted with a diameter of about 60 microns and a Numerical Aperture of about .35, the numerical aperture (NA) of an optical fiber being the sine of the vertex angle of the largest cone of meridional rays that can enter (or leave) an optical fiber.

35 This simple, direct coupling scheme allows for a coupling efficiency of at most 50%.

Background art

It is known to improve the coupling efficiency by locating a cylindrical lens between the laser chip and one end of the pigtail, with the cylindrical lens focusing the transverse component of the laser beam into the fiber core. In this respect reference can be made to EP-A-0 565 843 and also to "Hybrid laser-to-fiber coupler with a cylindrical lens" by Maeda M. et al., Applied Optics, Vol. 16, No. 7, July 1977, pp 1966-1970.

Such cylindrical lens does not modify the divergence of the beam in the plane of the slit axis, so that at a proper distance the beam from the laser chip is substantially reduced to having a circular cross section and can easily be coupled to the core of the optical fiber.

The pigtail is further fused to the final fiber, i.e. in general the fiber to be fed or in particular the fiber carrying the signal to be amplified, either at the other end of the feeding pigtail (Y coupler) or along a portion of the feeding pigtail length (X coupler). The coupling ratio of such coupler is proportional to the ratio of the squared diameter of the receiving fiber core to the squared diameter of the receiving fiber core plus the squared diameter of the feeding fiber core.

By using the SM-DC fiber technique an efficient feeding of a single-mode fiber core through a multi-mode fiber pigtail can be achieved. When the multi-mode core of the SM-DC fiber has the same diameter of the feeding fiber (i.e. 60 μm), the coupling ratio is about 0.5. To further increase the coupling ratio to the SM-DC fiber it is necessary to reduce the feeding fiber core diameter. With a diameter of less than 20 microns the coupling ratio could theoretically reach values greater than 0.9.

However, with a reduced core diameter of the multi-mode feeding fiber to improve the efficiency of the light transfer at the coupler, the efficiency of the light

transfer from the laser to the feeding fiber would become very poor even using a cylindrical lens.

Summary of the Invention

5 It is an object of the present invention to ameliorate one or more disadvantages of the prior art.

According to one aspect of the present invention there is provided a coupling arrangement for non-axial transfer of light power between a multi-mode light source, having a substantially circular emission with a divergence angle α_s , and a first multi-mode optical fiber with a cross section A_c , through a length of a second multi-mode optical fiber having an end with cross section area A_f coupled with said light source and one portion fused to said first multi-mode optical fiber,

wherein said second multi-mode optical fiber has a progressively tapered portion and is fused to said first multi-mode optical fiber at a region of the progressively tapered portion, and in that the relationship between the acceptance angle α_f of the second multi-mode optical fiber and the emission angle α_s of the light source is expressed by:

$$\alpha_f = k \times \alpha_s$$

where k is a positive constant greater than 1.

20 Preferably, a cylindrical lens is used to couple radiation from a multimode laser chip (or an array thereof) to a length of the second multimode fiber, in such a way that the divergence angle of the radiation beam propagating along the fiber is smaller than the acceptance angle of the fiber itself. The second fiber (either at the far end or along its length) is tapered, i.e. heated and pulled, in order to reduce its diameter and then a coupler is formed for example by twisting and fusing such tapered portion of the 25 second fiber on the first fiber to be fed, and in particular - according to a preferred industrial applicability of the invention - on the signal carrying fiber.



The above operation sequence is not compulsory. For example the coupler can be formed first and then connected to a multimode source or alternatively spliced to an already pigtailed multimode source. Other combinations are possible as well.

The operation of the invention can be understood substantially as follows.

5 It is well known to those skilled in the art that the quantity of radiation emitted by the unit surface of a source into the unit solid angle (the so called "radiance") cannot be increased by passive optics, therefore a reduction in size of the fiber core produces an increase in the divergence angle of the beam propagating along the fiber itself. As far as such angle remains smaller than the N.A. of the fiber, no loss is encountered and
10 it is therefore possible to produce efficient coupling between such tapered fiber and an untapered one.

A more detailed explanation can be found in the description of the annexed figures.

Additional and peculiar advantages are disclosed in the appended claims.

15

Brief Description of the Drawings

Preferred but non limiting embodiments of the invention will now be described in detail with reference to the attached drawings, in which:

20 Fig. 1 schematically shows a general arrangement for coupling a light source to an optical fiber through an intermediate optical fiber length;

Fig. 2 is a schematic front view of a multimode laser chip illustrating the outcoming laser beam shape:



- Fig. 3 schematically shows a multimode light source including a semiconductor laser diode and a cylindrical lens, coupled to a multi-mode fiber pigtail;
- Fig. 4 shows an embodiment of the invention wherein the intermediate optical fiber has been tapered in the coupling region and forms an Y coupler;
- Fig. 5 shows with greater details the twisting of the tapered feeding fiber core around the fed fiber core;
- Fig. 6 is an explaining view showing the intermediate multi-mode optical fiber, and the optical path inside it, for illustrating the general principle of the invention;
- Fig. 7 schematically shows the coupling region and light paths for the feeding of a SM-DC optical fiber carrying a single-mode radiation as a signal with a multi-mode beam carried in a multi-mode core;
- Fig. 8 shows a cross section profile of the end of the coupling region;
- Fig. 9 shows a cross section of the end of the coupling region in case the cladding of the two fibers is maintained;
- Fig. 10 shows a cross section of the end of the coupling region for a substantially elliptical fed fiber;
- Fig. 11 shows a cross section of the end of the coupling region for a substantially rectangular fed fiber.

25

Detailed description of a preferred embodiment

In the drawings the same references are used to indicate the same or similar components throughout all the Figures. With reference to Fig. 1, the illustrated coupling arrangement comprises a multi-mode light source LS having a substantially circular emission with an angle of divergence α as coupled to one end of an intermediate length of optical fiber IF, having an angle of acceptance α_f . A portion of the intermediate fiber IF is spliced or fused in the coupling region CR to an optical fiber FF carrying an information signal or the like, forming a so called X

30
35

coupler. A portion of the intermediate fiber IF can be coiled as shown at CF, if necessary. Of course the fiber IF could be spliced at its other end, forming a so called Y coupler.

5 As it is known the acceptance angle α_f of an optical fiber is a function of the refractive indexes of the core and cladding thereof. According to the invention, the acceptance angle α_f of the intermediate fiber IF at its coupling end with the light source LS is greater than the
10 emission angle α_s of the multi-mode light source itself. Thus a good coupling efficiency can be obtained.

Fig. 2 shows a front view of a multi-mode laser diode LD, not in scale, with a thickness of about 1 micron and a width in the order of 50 microns.

15 As illustrated in the Figure, the emission beam of the laser diode is substantially elliptical, with an angle of divergence of about 35-40 degrees in the plane perpendicular to the laser junction (i.e. a plane along the thickness of 1 micron), and an angle of divergence of about
20 10-15 degrees in the plane of the laser junction (plane along the width of 50 microns).

Three subsequent traces B1, B2 and B3, progressively spaced away from the source of the beam (the diode front surface) are shown for illustrative purposes only. It is apparent
25 that, being the greater diverging angle in correspondence with the shorter side of a rectangle, at a certain distance from the diode surface there will be a cross section of the laser beam (here B2) substantially circular, beyond which the relative dimensions of the ellipse appear exchanged
30 (that is the major axis of the elliptical beam is rotated by 90 degrees).

Figs. 3 to 7 illustrate a preferred arrangement of the invention that is particularly useful in coupling a pump multi-mode light source with one end of a feeding optical
35 fiber which in turn is coupled to an SM-DC fiber length as a peculiar component of an optical amplifier.

With reference to Fig. 3, a semiconductor laser diode LD emitting a multi-mode radiation or light beam LB is coupled through a cylindrical lens CL with one end of an intermediate multi-mode optical fiber IF.

5 The cylindrical lens CL is located in the elliptical light beam LB between the laser diode LD and the feeding fiber IF so as to progressively reduce the divergence of the transverse component of the laser beam until it becomes equal to or possibly even smaller than the divergence of
10 the parallel component, thus forming a substantially circular beam that is coupled into the feeding fiber. The means through which the components can be positioned in respect of each other are conventional in the art and therefore have not been illustrated.

15 In accordance with the invention the emission angle α_s of the beam outcoming from the cylindrical lens CL is lower than the acceptance angle α_f of the feeding fiber to which it is coupled. In terms of Numerical Aperture of the feeding fiber itself it means that the NA of the fiber has
20 to be greater than 0.3 in order to accept a beam of 35 degrees.

The other end of the feeding fiber IF (or in case a remote portion of the feeding fiber) is fused together with the optical fiber FF as shown in Fig. 4. The splicing area
25 designated with CR forms a so called Y coupler, since the splicing with the fiber FF takes place at the end of the feeding fiber IF.

It is further to point out that the optical fiber FF could also be the active fiber of a fiber laser.

30 Still in accordance with the invention, the cross sectional area of the feeding fiber IF in the coupling region CR is progressively reduced (so-called adiabatic core diameter reduction) until it reaches a value between 0.8 and 0.1 with respect to the starting value i.e. the diameter where
35 the light beam LB enters the fiber. In other words the squared ratio of the diameters is comprised between 1.5 and

100.

Preferably the ratio between the minimum cross section area of the tapered feeding fiber IF and the initial cross section area thereof is from 0.01 to 0.7 and a more preferred value is about 0.1.

Preferably the ratio between the cross section area of the feeding fiber IF and the cross section area of the fed fiber FF in the coupling region CR is from 0.01 to 0.99.

It is preferred that the tapered portion of the feeding fiber is as shortest as possible, compatibly with the fiber resistance (capability) of withstanding a strong reduction of its cross section.

This is accomplished by drawing the feeding IF or at least a section thereof at a given temperature, then twisting the narrowing portion around the signal fiber FF and in contact therewith (see Fig. 5), and then slightly pulling the fibers raising the temperature until they merge together. This way one obtains a better contact. Preferably the progressively tapered portion of the multi-mode feeding optical fiber IF fused to said multi-mode optical fiber FF is helically wound around this latter.

When an X coupler is used, at least a portion of the feeding fiber has a progressively decreasing diameter, falling within the above mentioned ranges, and in this portion is joined to the fed fiber FF.

With reference to Fig. 6 will be illustrated the principle upon which the invention is based.

As previously mentioned, the emission angle α_s of the multi-mode source LS is a portion of the angle of acceptance α_f of the intermediate multi-mode fiber IF, and α_f is linked to the Numerical Aperture NA of the fiber by the relationship:

$$NA = \sin \alpha_f$$

Due to the fiber tapering the propagation angle of the pump laser radiation carried by the feeding fiber is gradually increased along the tapered region.

Assuming that the fusion between the feeding fiber IF and the fed fiber FF occurs along the entire tapered region of the feeding fiber IF and that the tapering ends with a negligibly small diameter, the relationship between the
5 final divergence angle α_c and the initial one α_s is:

$$\alpha_c \approx \alpha_s \cdot ((A_c + A_f)/A_c)^{1/2}$$

where A_c and A_f are the cross sectional areas of the fed fiber FF and the untapered feeding fiber IF respectively. Provided that, for given values of A_c and A_f , α_s is chosen
10 in such a way that α_c does not exceed the acceptance angle of the fibers (let assume for sake of ease that the N.A. of both fibers are equal), a reduction of the feeding fiber core diameter is obtained without losses of light from the fiber itself due to the light angle of propagation
15 increase.

In case the fusion between the the two fibers does not begin where the tapering of the feeding fiber starts, but rather at a different position within the tapered section, with a cross sectional area A_t of the feeding fiber, the
20 above expression becomes:

$$\alpha'_c \approx \alpha_s \cdot (A_f/A_t)^{1/2} \cdot ((A_t + A_c)/A_c)^{1/2}$$

corresponding to a larger increase in the divergence angle. The preferred arrangement is therefore the one described above.

25 Fig. 7 shows with more detail the coupling region CR when a SM-DC fiber is adopted, including an inner concentrical single-mode core along which an optical signal carrying information propagates. Moreover the Figure schematically illustrates the light path of the pumping radiation when
30 this latter is transferred from the multi-mode feeding fiber IF to the multi-mode core of the SM-DC fiber FF.

In order to maintain an efficient coupling the Numerical Aperture of the multi-mode core of the fed fiber FF has to be equal or greater than the Numerical Aperture of the
35 feeding fiber IF.

It is worth to point out that, as described above, the most

efficient coupling is achieved if the contact between said multimode optical fiber FF and said feeding fiber IF is substantially accomplished along the entire tapered region of the IF fiber.

5 Fig. 8 illustrates a cross section of the coupling region CR (before the merging of the two fibers) where both the optical fibers have a substantially circular cross-section and are without cladding at the junction. For the SM-DC fiber the second (outer) cladding is considered to be
10 removed.

Although the optimum coupling is obtained when both fibers are not provided with cladding layers, the invention applies also to fibers with unremovable cladding. In this case the coupling ratio will be reduced by an additional
15 constant factor, which depends on the thickness of the cladding.

Fig. 9 shows a cross section of the coupling region CR with two circular fibers still retaining the outer claddings.

Fig. 10 illustrates a multi-mode optical fed fiber that
20 have substantially elliptical cross section, and finally Fig. 11 shows a multi-mode optical fed fiber having substantially rectangular cross section. Of course one or both the feeding fiber IF and the optical fiber FF can have one of the above illustrated cross sections.

25 With reference to figs. 8, 9, 10, and 11, it is evident that the ratio of the core area A_c at the coupling end with the source LS to the core area A_f at the fused end, is larger than the ratio α_f/α_s of the acceptance angle α_f of the feeding fiber IF to the initial emission angle α_s of
30 the light source LS.

When using a single-mode core fiber, the core is preferably doped with a relatively large amount of ions of rare earth or ions of transitional metal, or in case with a combination thereof.

35 For example said single-mode core can be doped with both Ytterbium and Erbium ions, or Neodimium ions, or

Ytterbium ions alone or Chromium ions.

Although preferred embodiments of the invention have been disclosed, several modifications and changes can be made to the same within the scope of the inventive idea.

The claims defining the invention are as follows:

1. A coupling arrangement for non-axial transfer of light power between a multi-mode light source, having a substantially circular emission with a divergence angle α_s , and a first multi-mode optical fiber with a cross section A_c , through a length of a second multi-mode optical fiber having an end with cross section area A_f coupled with said light source and one portion fused to said first multi-mode optical fiber,

wherein said second multi-mode optical fiber has a progressively tapered portion and is fused to said first multi-mode optical fiber at a region of the progressively tapered portion, and in that the relationship between the acceptance angle α_f of the second multi-mode optical fiber and the emission angle α_s of the light source is expressed by:

$$\alpha_f = k \times \alpha_s$$

where k is a positive constant greater than 1.

2. A coupling arrangement as claimed in claim 1, wherein said constant k is greater than $((A_f + A_c) / A_c)^{1/2}$

where:

- A_f is the cross section area of the second multi-mode optical fiber coupled with said light source, and
- A_c is the cross section area of the first multi-mode optical fiber.

3. A coupling arrangement as claimed in either of claims 1 or 2, wherein the region of fusion between said second multi-mode optical fiber and said first multi-mode optical fiber coincides substantially with the whole tapered region of said second multi-mode optical fiber.

4. A coupling arrangement as claimed in any one of the preceding claims, wherein said light source has a substantially elliptical emission and includes a device for converting such elliptical emission into a substantially circular emission with said divergence angle (α_s).

5. A coupling arrangement as claimed in any one of the preceding claims, wherein said light source comprises a multi-mode semiconductor laser diode having a substantially rectangular radiating aperture, and a cylindrical lens located in the light beam of said laser diode, between said laser diode and the second multi-mode optical fiber.



6. A coupling arrangement as claimed in any one of the preceding claims, wherein said first multi-mode optical fiber further contains an additional concentric single-mode core.

5 7. A coupling arrangement as claimed in any one of the preceding claims, wherein said first multi-mode optical fiber further contains an additional concentric single-mode doped core.

8. A coupling arrangement as claimed in claim 7, wherein said single-
10 mode core is heavily doped with ions selected from the group of rare earth and transitional metal ions, or a combination thereof.

9. A coupling arrangement as claimed in claim 7, wherein said single-
mode core is doped with both Ytterbium and Erbium ions.

15

10. A coupling arrangement as claimed in claim 7, wherein said single-
mode core is doped by Neodimium ions.

11. A coupling arrangement as claimed in claim 7, wherein said single-
20 mode core is doped by Ytterbium ions.

12. A coupling arrangement as claimed in claim 7, wherein said single-
mode core is doped by Chromium ions.

25 13. A coupling arrangement as claimed in any one of the preceding claims, wherein said first multi-mode optical fiber is the active fiber of an optical amplifier.

30 14. A coupling arrangement as claimed in any one of the preceding claims, wherein said first multi-mode optical fiber is the active fiber of a fiber laser.

15. A coupling arrangement as claimed in any one of the preceding claims, wherein said second multi-mode optical fiber is coupled to said first multi-mode optical fiber as an X-coupler configuration.

35

16. A coupling arrangement as claimed in any one of the preceding claims, wherein said second multi-mode optical fiber is coupled to said first multi-mode optical fiber as an Y-coupler configuration.



17. A coupling arrangement as claimed in any one of the preceding claims, wherein both said first and second multi-mode optical fibers are not provided with cladding layers at the fused area.

5

18. A coupling arrangement as claimed in any one of the preceding claims, wherein at least one of said first multi-mode optical fiber and second multi-mode optical fiber is provided with a cladding layer at the fused area.

10

19. A coupling arrangement as claimed in claim 1, wherein at least one of said first multi-mode optical fiber and said second multi-mode optical fiber has a cross section that is substantially circular.

15

20. A coupling arrangement as claimed in claim 1, wherein at least one of said first multi-mode optical fiber and said second multi-mode optical fiber has a cross section that is substantially elliptical.

20

21. A coupling arrangement as claimed in claim 1, wherein at least one of said first multi-mode optical fiber and said second multi-mode optical fiber has a cross section that is substantially rectangular.

25

22. A coupling arrangement as claimed in any one of the preceding claims, wherein the ratio between the minimum cross section area of the second multi-mode optical fiber and the initial cross section area thereof is from 0.01 to 0.7.

23. A coupling arrangement as claimed in claim 22, wherein the ratio between the minimum cross section area of the second multi-mode optical fiber and the initial cross section area thereof is about 0.1.

30

24. A coupling arrangement as claimed in any one of the preceding claims, wherein the ratio between the cross section area of the second multi-mode optical fiber and the cross section area of the first multi-mode optical fiber in the coupling region is from 0.01 to 0.99.

35

25. A coupling arrangement as claimed in claim 24, wherein the ratio between the minimum cross section area of the second multi-mode optical fiber and the cross section area of the first multi-mode optical fiber in the coupling region is about 0.1.



26. A coupling arrangement as claimed in any one of the preceding claims, wherein said progressively tapered portion of said second multi-mode optical fiber fused to said first multi-mode optical fiber is helically wound around the latter.

5

27. A coupling arrangement, substantially as herein described in relation to any embodiment with reference to the drawings.

DATED this Seventeenth Day of August 1998

10

Italtel S.P.A.

Ire-Polus Co.

Patent Attorneys for the Applicants

SPRUSON & FERGUSON



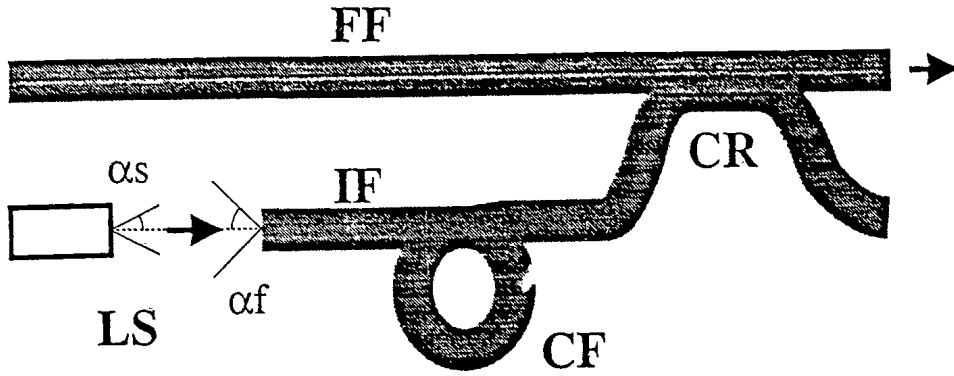

fig. 1

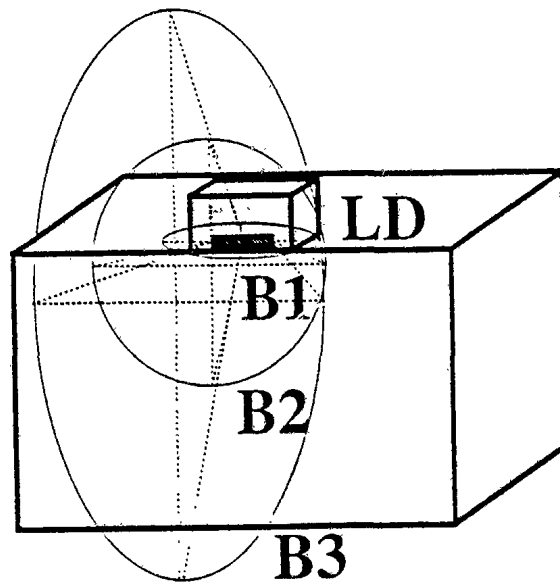

fig. 2

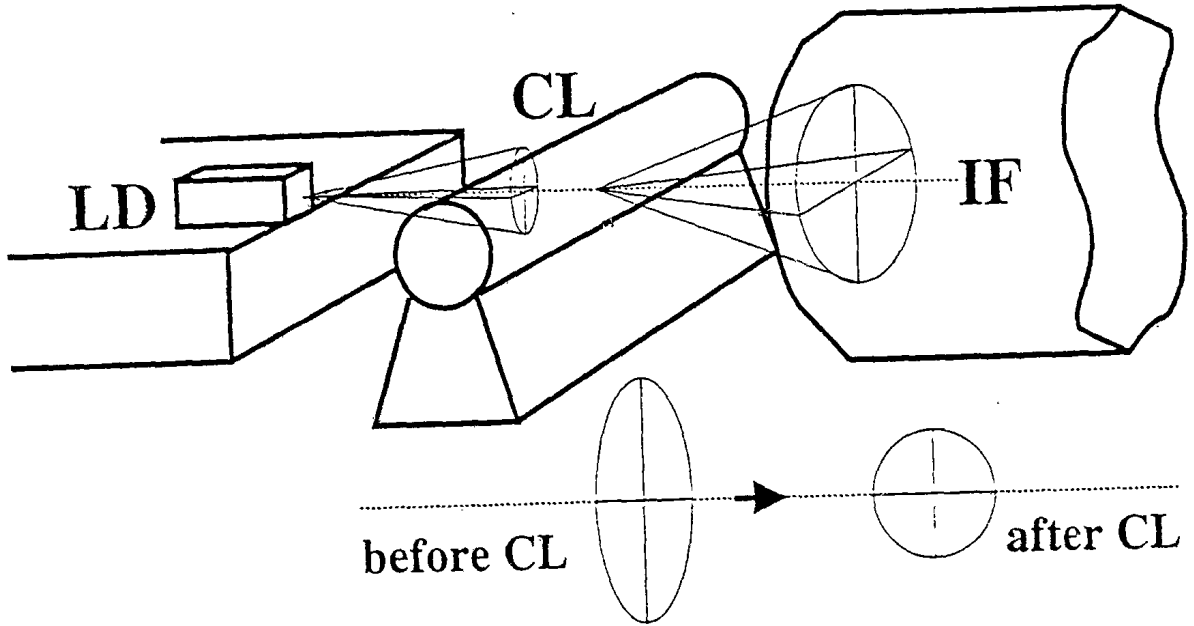

fig. 3

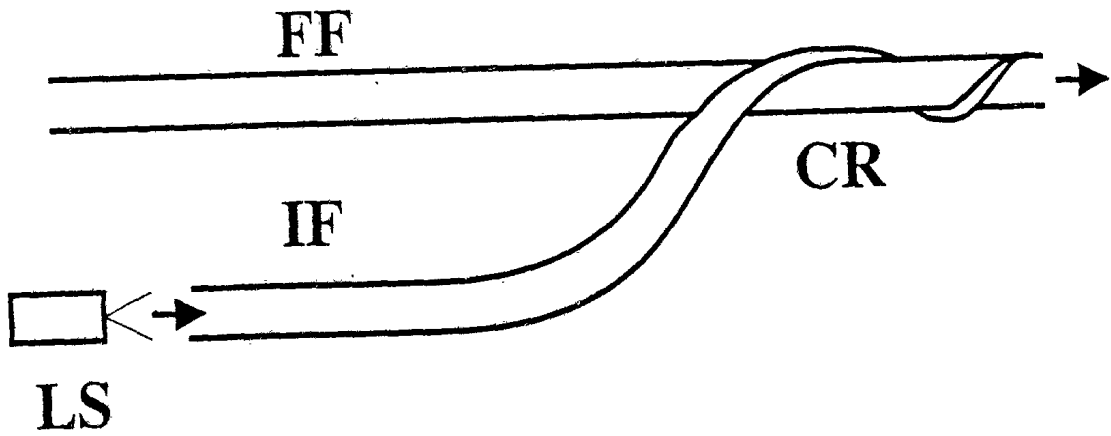

fig. 4

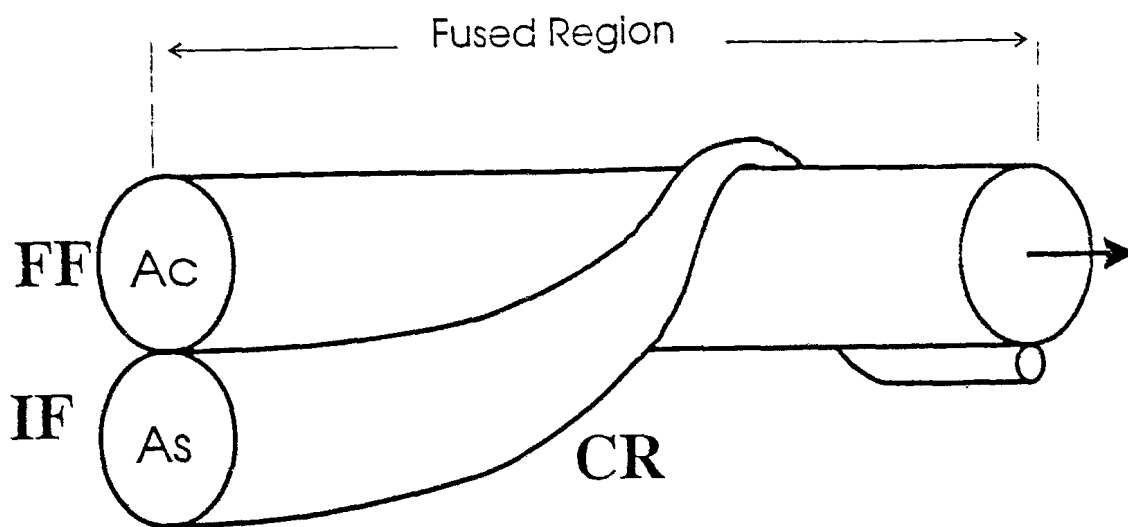

fig. 5

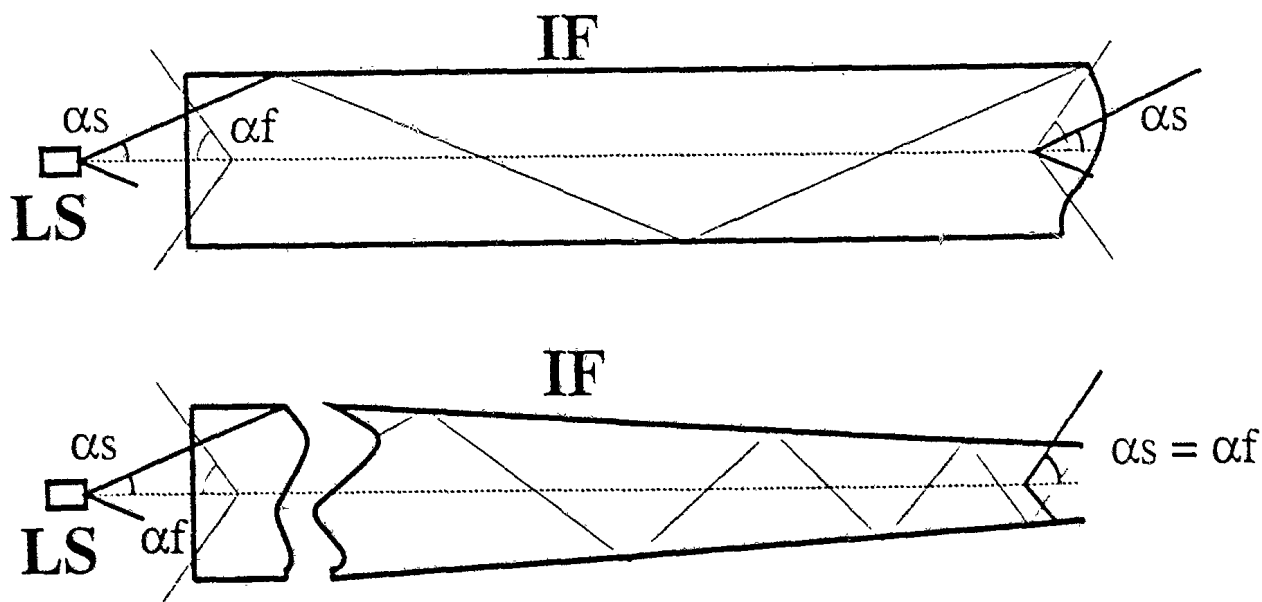

fig. 6

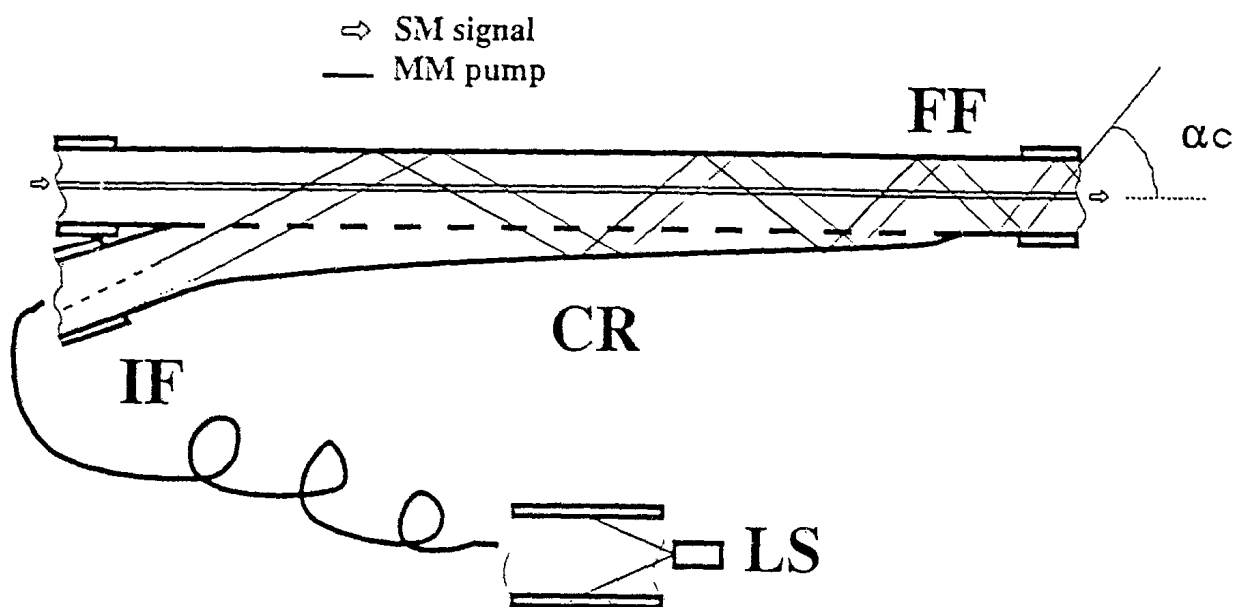

fig. 7

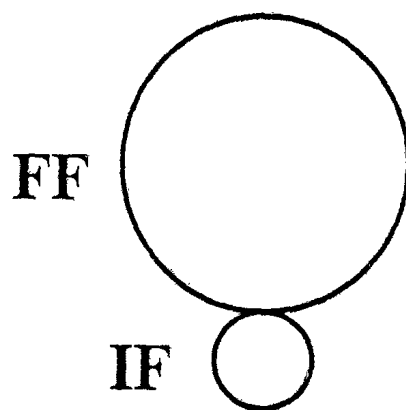

fig. 8

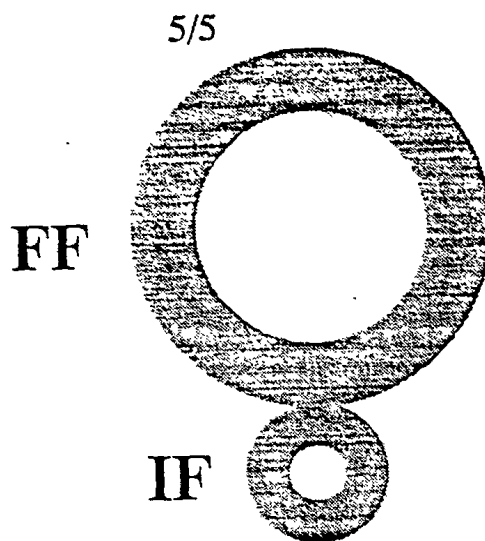

fig. 9

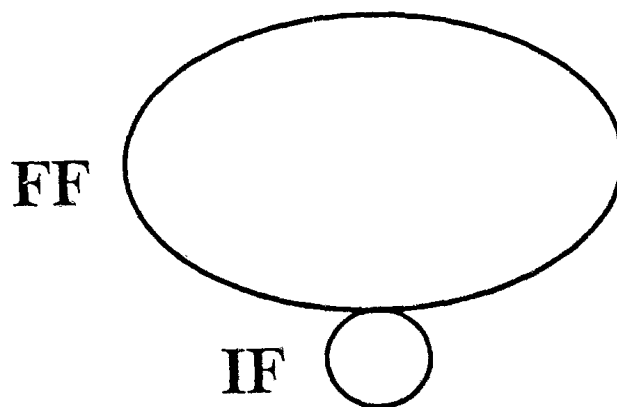

fig. 10

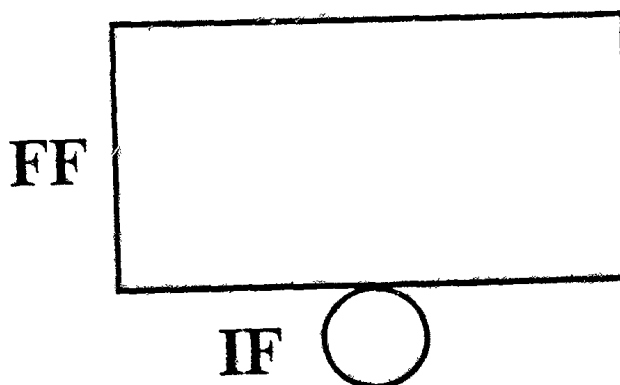

fig. 11

INTERNATIONAL SEARCH REPORT

International Application No
PCT/IT 94/00218

A. CLASSIFICATION OF SUBJECT MATTER
IPC 6 H01S3/06 G02B6/28 G02B6/42

According to International Patent Classification (IPC) as to both national classification and IPC

B. FIELDS SEARCHED
 Minimum documentation searched (classification system followed by classification symbols)
IPC 6 H01S G02B

Documentation searched other than minimum documentation to the extent that such documents are included in the fields searched

Electronic data base consulted during the international search (name of data base and, where practical, search terms used)

C. DOCUMENTS CONSIDERED TO BE RELEVANT

Category	Citation of document, with indication, where appropriate, of the relevant passages	Relevant to claim No.
A	EP,A,0 136 871 (THE BOARD OF TRUSTEES OF THE LELAND STANFORD) 10 April 1985 see page 6, line 33 - line 36 see page 7 - page 8 see page 9, line 1 - line 10 see figures 1,2	1,10
A	---	
A	JOURNAL OF LIGHTWAVE TECHNOLOGY., vol.9, no.11, November 1991, NEW YORK US pages 1508 - 1517 R.GRIFFIN ET.AL. 'Asymmetric multimode couplers' see page 1508 - page 1511	1,19
A	---	
A	EP,A,0 497 243 (CSELT) 5 August 1992 see the whole document	1,6,7, 13,14

	-/--	

Further documents are listed in the continuation of box C. Patent family members are listed in annex.

* Special categories of cited documents :

<p>"A" document defining the general state of the art which is not considered to be of particular relevance</p> <p>"E" earlier document but published on or after the international filing date</p> <p>"I" document which may throw doubts on priority claim(s) or which is cited to establish the publication date of another citation or other special reason (as specified)</p> <p>"O" document referring to an oral disclosure, use, exhibition or other means</p> <p>"P" document published prior to the international filing date but later than the priority date claimed</p>	<p>"T" later document published after the international filing date or priority date and not in conflict with the application but cited to understand the principle or theory underlying the invention</p> <p>"X" document of particular relevance: the claimed invention cannot be considered novel or cannot be considered to involve an inventive step when the document is taken alone</p> <p>"Y" document of particular relevance: the claimed invention cannot be considered to involve an inventive step when the document is combined with one or more other such documents, such combination being obvious to a person skilled in the art.</p> <p>"&" document member of the same patent family</p>
--	--

Date of the actual completion of the international search 24 August 1995	Date of mailing of the international search report 06.09.95
--	---

Name and mailing address of the ISA European Patent Office, P.B. 5818 Patentlaan 2 NL - 2280 HV Rijswijk Tel. (+ 31-70) 340-2040, Tx. 31 651 epo nl, Fax (+ 31-70) 340-3016	Authorized officer <p style="text-align: center;">Mathyssek, K</p>
---	--

INTERNATIONAL SEARCH REPORT

 International Application No
 PCT/IT 94/00218

C.(Continuation) DOCUMENTS CONSIDERED TO BE RELEVANT

Category *	Citation of document, with indication, where appropriate, of the relevant passages	Relevant to claim No.
A	OPTICAL FIBER COMMUNICATION CONFERENCE 1992, 2 February 1992, SAN JOSE ,CALIFORNIA,US pages 32 - 33 J.D.MINELLY ET.AL. 'High-gain fiber power amplifier tandem-pumped by a 3-w multistribe diode' see the whole document ---	1,8-10, 13,14
A	EP,A,0 180 861 (POLAROID CORPORATION) 14 May 1986 see column 5, line 44 - line 56 see claims see figure 2 ---	1,10,12
A	INTERNATIONAL CONFERENCE ON INTEGRATED OPTICS AND OPTICAL FIBER COMMUNICATIONS, 1977, TOKYO pages 293 - 296 Y.NURSE ET.AL. 'PERFORMANCE OF SINGLE MODE FIBER COUPLERS AND POWER DIVIDERS USING TAPERED STRUCTURE' see the whole document ---	1,3,16
A	PATENT ABSTRACTS OF JAPAN vol. 9, no. 257 (P-396) (1980) 15 October 1985 & JP,A,60 107 007 (FUJIKURA) see abstract ---	1,15
A	APPLIED OPTICS., vol.16, no.7, July 1977, NEW YORK US pages 1966 - 1970 M.MAEDA ET.AL. 'Hybrid laser to fiber coupler with a cylindrical lens' cited in the application see the whole document -----	4,5

INTERNATIONAL SEARCH REPORT

Information on patent family members

International Application No

PCT/IT 94/00218

Patent document cited in search report	Publication date	Patent family member(s)	Publication date
EP-A-0136871	10-04-85	US-A- 4553238	12-11-85
		AU-A- 3345384	04-04-85
		CA-A- 1210486	26-08-86
		DE-D- 3486288	14-04-94
		DE-T- 3486288	08-09-94
		JP-C- 1843955	12-05-94
		JP-A- 60115277	21-06-85
EP-A-0497243	05-08-92	CA-A- 2059715	31-07-92
		JP-A- 6164032	10-06-94
		US-A- 5263036	16-11-93
EP-A-0180861	14-05-86	JP-A- 61119087	06-06-86