

Jan. 31, 1967

G. MARCHIOLI

3,300,935

JOINING TUBULAR ROOF BEAMS AND MEANS THEREFOR

Filed May 5, 1964

2 Sheets-Sheet 1

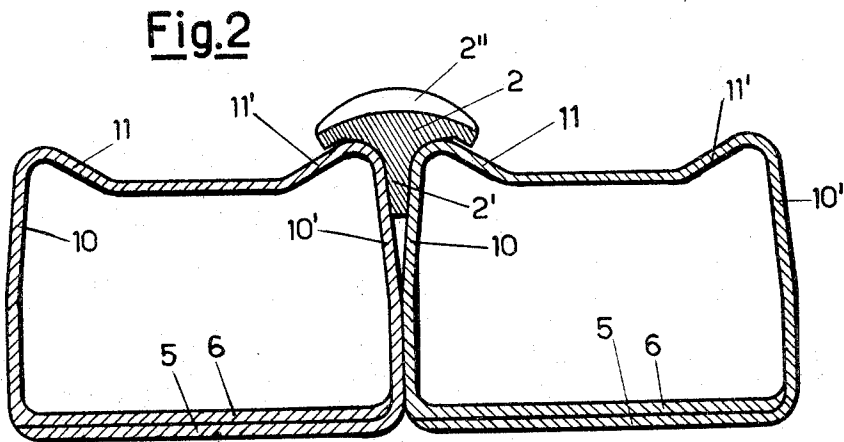
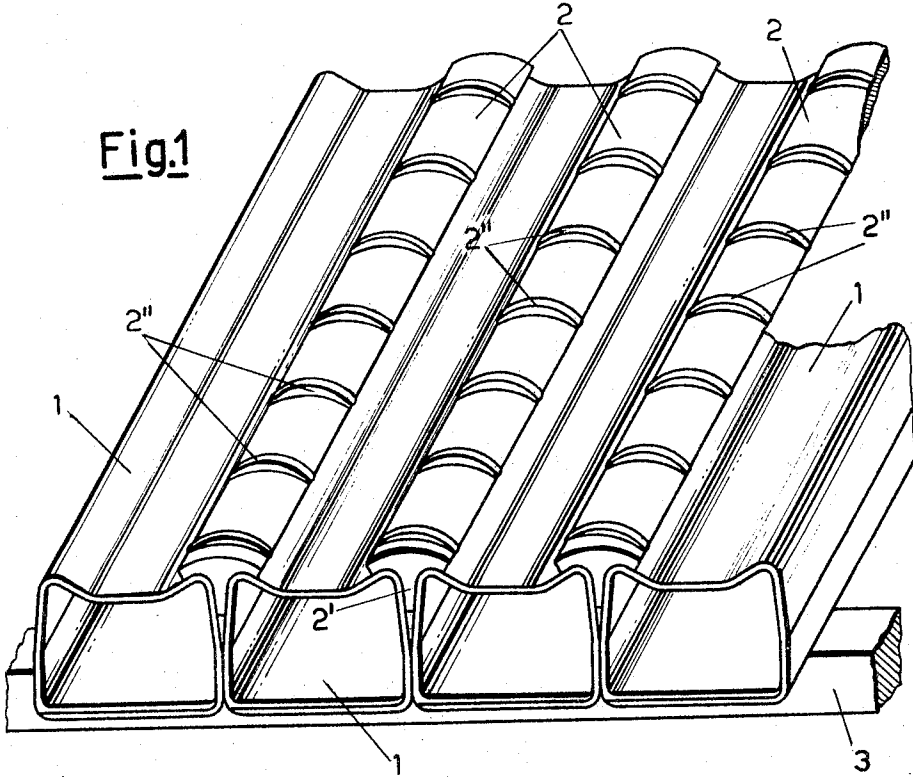

INVENTOR.

GIORGIO MARCHIOLI

BY

*Enrico De Luca*  
ATTORNEY

Jan. 31, 1967

G. MARCHIOLI

3,300,935

JOINING TUBULAR ROOF BEAMS AND MEANS THEREFOR

Filed May 5, 1964

2 Sheets-Sheet 2

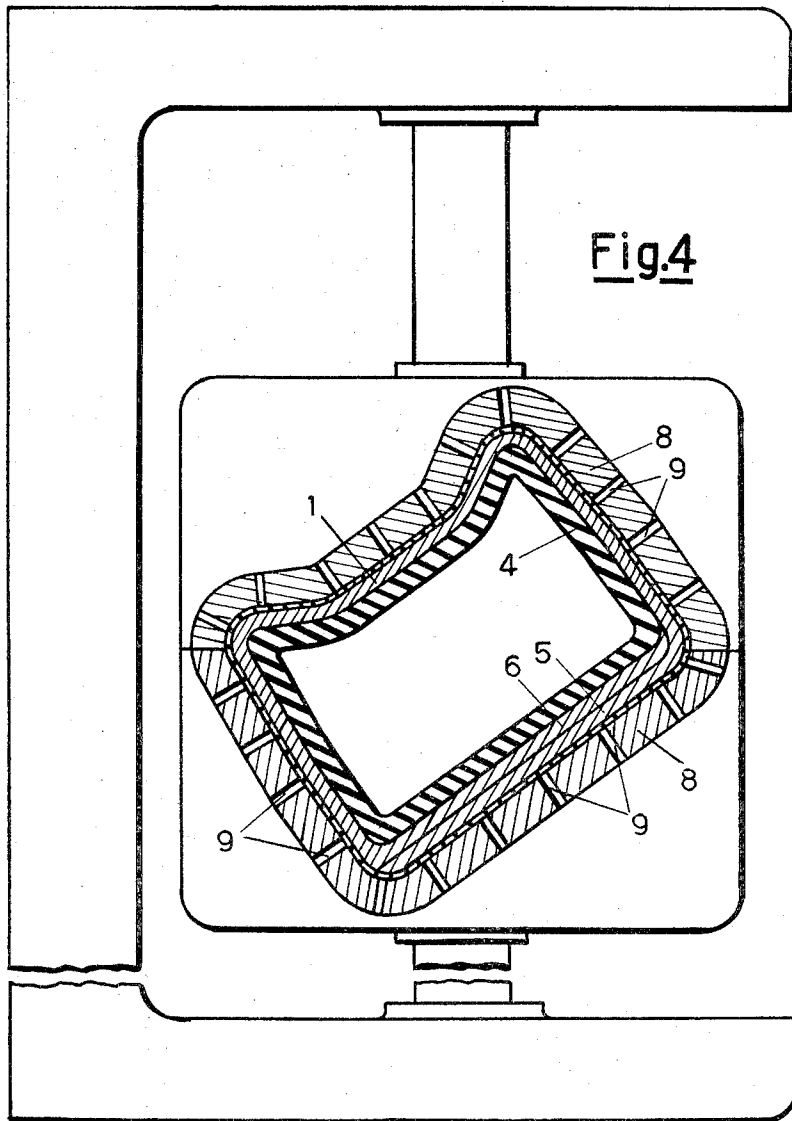
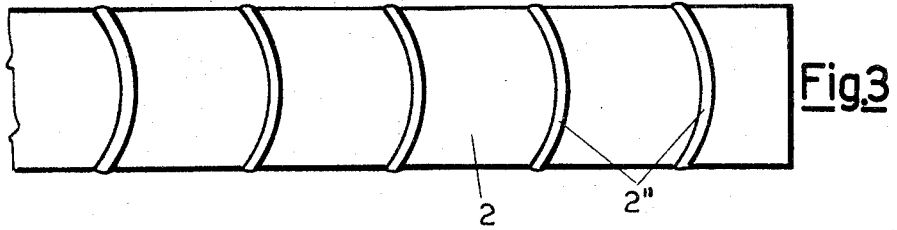

INVENTOR.

GIORGIO MARCHIOLI

BY

*Armed & Brown*

ATTORNEY

1

2

3,300,935

**JOINING TUBULAR ROOF BEAMS AND MEANS THEREFOR**

Giorgio Marchioli, Via G. B. Morgagni 22, Milan, Italy

Filed May 5, 1964, Ser. No. 364,995

Claims priority, application Italy, May 14, 1963,

10,054/63, Patent 696,106

1 Claim. (Cl. 52-468)

It is an object of the present invention to provide a self-supporting roof characterized in that it is constituted by elementary beams of asbestos-cement of tubular shape having substantially quadrangular cross-sections and being placed side by side of one another, and T-shaped butt-straps are fitted with their ribs between adjacent beams to provide seals between the side-by-side arranged surfaces thereof.

Preferably each elementary tubular beam for the construction of the roof has a square or rectangular cross-section, the base wall of which has thickness double that of the other walls in view of the fact that, for asbestos cement, tensile strength is about one-third of compression strength:

$$\sigma_t \leq \frac{1}{3} \sigma_c$$

and the walls of which have a terminal portion slightly inclined and the side walls of which have upper portions that converge slightly and project slightly above the central portion of the top wall of the tubular beam so that the upper portions of the confronting side walls of adjacent beams define a wedge-shaped space to receive a rib of substantially triangular cross-section depending from the T-shaped butt-strap.

The top or upper wall of the tubular beam assumes the shape of a shallow channel having flat or concave bottom at its center and sides inclined upwardly and outwardly therefrom.

The T-shaped butt-strap is preferably formed with an arched upper outside surface which is provided with transverse ribs projecting at intervals therealong to deviate towards the adjacent beams the water that flows therealong and to prevent said water from accumulating, particularly at the locations of any possible junctions between the pieces composing said butt-strap.

A very advantageous process for manufacturing said tubular beams consists in preparing a plate of asbestos-cement of any desired length with the asbestos fibers preferably oriented in the direction of the length of the plate and of a width equal to about one and one-fourth times the perimeter of the finished beam, in winding up said plate in the direction of width, while it is still in the plastic state, around an expandible core of nearly quadrangular cross-section, with the two extreme borders of the mould plate being superimposed over the whole length of the lower side or base of said core, in introducing said plate wound up on the core, and surrounded by a thin yielding net, into a metallic die the inner walls of which have the profile and cross-section of the finished beam, in subsequently causing the expansion of the core to definitively compress the plate of asbestos-cement against the die thereby expelling the excess water, and in extracting the tubular beam so shaped from the die.

The roof according to the invention affords numerous considerable advantages among which the following may be cited:

(a) It is self-supporting and, therefore, directly applicable to end-supports, without requiring any intermediate support or other subsidiary armature;

(b) It permits considerable reduction in the slant of the roof thanks to the continuity of the exposed surface; on the other hand, the less pronounced slant renders the

thermal insulation more effective due to the air enclosed in the beam;

(c) It is stainless, rot resistant, sound-proof and impermeable;

(d) It is economical though it has a considerable mechanical strength;

(e) It can be sawn, painted, and also shaped for particular applications;

(f) It is monolithic.

In the following table have been indicated some structural data that better illustrate the characteristics of the elementary beams constituting the roof:

b, cm. -----	20
a, cm. -----	30
s, mm. -----	6
l, m. -----	7.50
L, m. -----	8.00
P, kg./m. -----	14
K, admissible load, kg./m. <sup>2</sup> -----	150

wherein:

b=height of the beam

a=width

s=thickness of the plate constituting the beam

l=center to center distance between the supports

L=length of the beam

P=own weight

K=admissible load in kg. per square meter of roof area.

In the accompanying drawings, for the sake of greater clearness and merely by way of example, there is illustrated one embodiment of the invention:

FIG. 1 is a fragmentary perspective view of a roof according to the invention;

FIG. 2 is an enlarged cross-sectional view of two contiguous tubular beams of the roof and of the sealing butt-strap therebetween;

FIG. 3 is a top plan view of the butt-strap; and

FIG. 4 is a cross-sectional view of apparatus for the manufacturing of a tubular beam.

The roof illustrated in FIG. 1 is essentially constituted by a plurality of tubular beams 1 placed side by side and resting upon or anchored to supporting beams 3, and by butt-straps 2 the function of which is to avoid infiltration of water between the zones of contact of adjacent assembled tubular beams. In the case illustrated the individual tubular beams are obtained from plates or sheets of asbestos-cement, as follows:

Starting from a plate or sheet obtained in known manner from a mix of asbestos-cement, said plate is bent or wrapped in the direction of its width around a core 4 of substantially rectangular cross-section, of rubber or other inflatable material, taking care that the longitudinal borders 5-6 of the plate are superimposed on each other. The assembly of the core with the plate wrapped thereon is introduced into the steel die 8 (which may be formed of two separable pieces) lined with one or more screens and provided with a plurality of holes 9 for the exit of water. Finally, compressed air or water is introduced into the core for inflating the latter and thereby compelling the plate to be compressed against the inner face of the die 8 to assume its definitive shape. Then the core is deflated so as to be easily removable from the tubular beam. The high pressure employed, for example, of the order of magnitude of 80 to 100 kg./cm.<sup>2</sup>, ensures the best ratio of residual water to cement (0.25) and renders the asbestos-cement structure monolithic. From FIG. 2 one sees clearly the actual shape that the beam definitely assumes: it has a base of double thickness as compared to that of the other walls, and the vertical or side walls have upper portions 10-10'

3

that are slightly inclined or converging and projecting upwards, and joined with the side portions 11-11' of the upper wall which is centrally depressed, in such a way as to make the upper wall assume the profile of a shallow channel with inclined sides, to facilitate the conveying of water therealong. The convergence of the upper portions 10-10' has also the purpose of permitting an application of the butt-strap 2 between two contiguous beams. Said butt-strap 2, which also is of asbestos-cement, has substantially a T-shaped cross-section, as is shown in FIG. 2, and includes a rib 2' which is wedge-shaped and depend centrally from a cap having an upper surface which is arched or flat and provided with ridges or cords 2'' projecting transversally with respect to the length of the strap 2 and preferably being curved in the direction of the roof slant, for the purpose of facilitating the deflection and the conveyance of the water towards the shallow channels in the tops of the contiguous beams.

The embodiments of the invention in which an exclusive property or privilege is claimed are defined as follows:

A self-supporting roof structure to be carried by spaced supporting beams, comprising a plurality of elongated, tubular roof beams of asbestos-cement arranged side by side in abutting relationship along a substantial portion of the side walls thereof, and spanning and resting on said supporting beams, each of said roof beams being of generally quadrangular cross-section, said roof beams having side walls with converging upper portions and a top wall which is centrally depressed between said side walls, precast elements in the form of substantially T-

4

shaped butt-straps wedgedly secured between the adjacent roof beams, each butt-strap including a cap bridging the top walls of said adjacent roof beams and a rib depending centrally from said cap and being wedge-shaped in cross-section to fit between said upper portions of the confronting side walls of said adjacent roof beams, to prevent infiltration of water between adjacent roof beams, each cap of each butt-strap having longitudinally spaced ridges extending transversely along the upper surface thereof.

References Cited by the Examiner

UNITED STATES PATENTS

15	202,784	4/1878	Brown	52-469
	511,387	12/1893	White	52-469
	550,325	11/1895	Kinnear	52-465 X
	646,495	4/1900	Jager	52-468
	1,152,236	8/1915	Swanson	52-13
20	1,218,676	3/1917	Lester	52-468
	2,835,019	5/1958	Thiess	264-86
	3,218,377	11/1965	Grewigni	264-86

FOREIGN PATENTS

25	330,340	6/1930	Great Britain.
	1,004,426	11/1915	France.
	1,080,763	6/1954	France.

FRANK L. ABBOTT, *Primary Examiner.*

30 RICHARD W. COOKE, JR., *Examiner.*

M. O. WARNECKE, *Assistant Examiner.*