

No. 676,801.

Patented June 18, 1901.

I. SEDGWICK.
STEAM ENGINE.

(Application filed Feb. 3, 1900.)

(No Model.)

5 Sheets—Sheet 1.

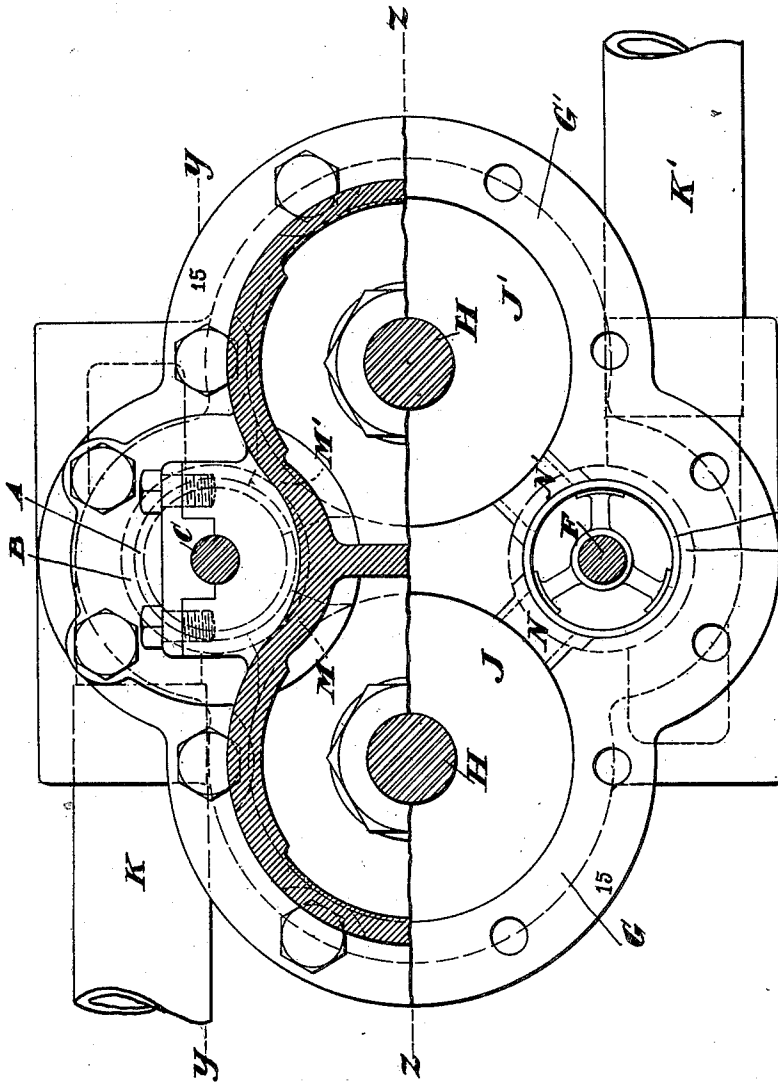

Fig. 1.

Witnesses:

H. L. Canby
L. M. Hill

Inventor:
Isham Sedgwick
By *Robert M. Randall*
Attorney:

No. 676,801.

Patented June 18, 1901.

I. SEDGWICK.
STEAM ENGINE.

(Application filed Feb. 3, 1900.)

(No Model.)

5 Sheets—Sheet 2.

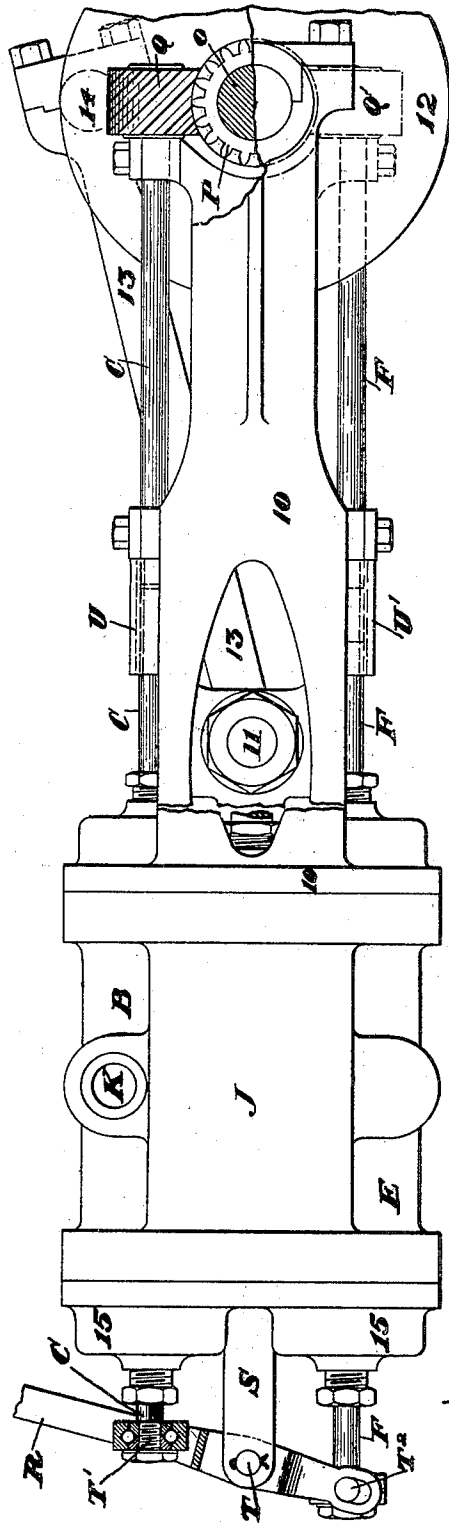

Fig. 2.

Inventor:
Isham Sedgwick.

By Robert M. Randle,
Attorney.

Witnesses:
Frank S. Davis,
H. L. Canby.

No. 676,801.

Patented June 18, 1901.

I. SEDGWICK.
STEAM ENGINE.

(Application filed Feb. 3, 1900.)

(No Model.)

5 Sheets—Sheet 3.

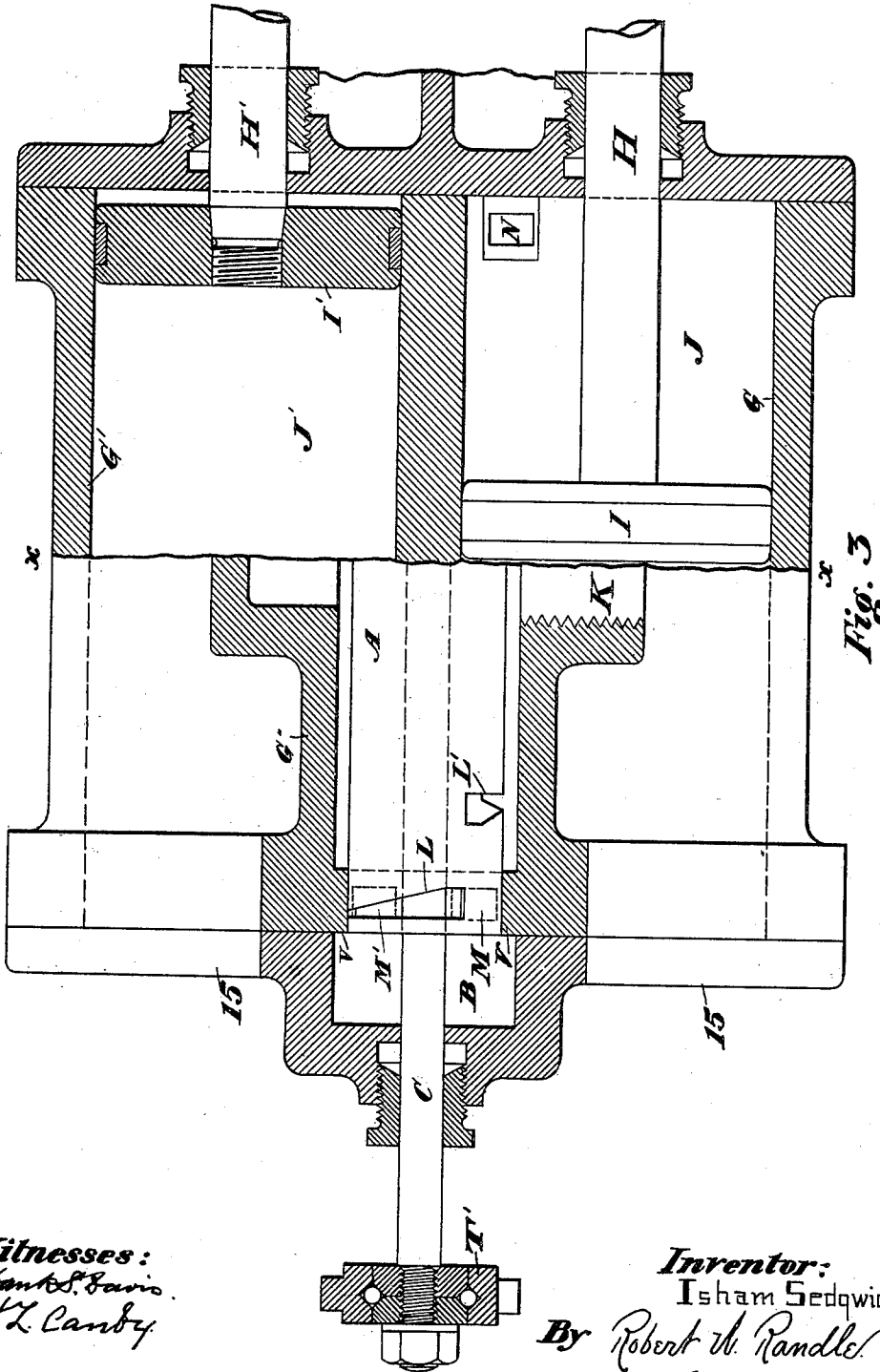

Fig. 3

Witnesses:
Frank S. Davis
H. L. Canby

Inventor:
Isham Sedgwick
By *Robert M. Randle*
Attorney.

No. 676,801.

Patented June 18, 1901.

I. SEDGWICK.
STEAM ENGINE.

(Application filed Feb. 3, 1900.)

(No Model.)

5 Sheets—Sheet 4.

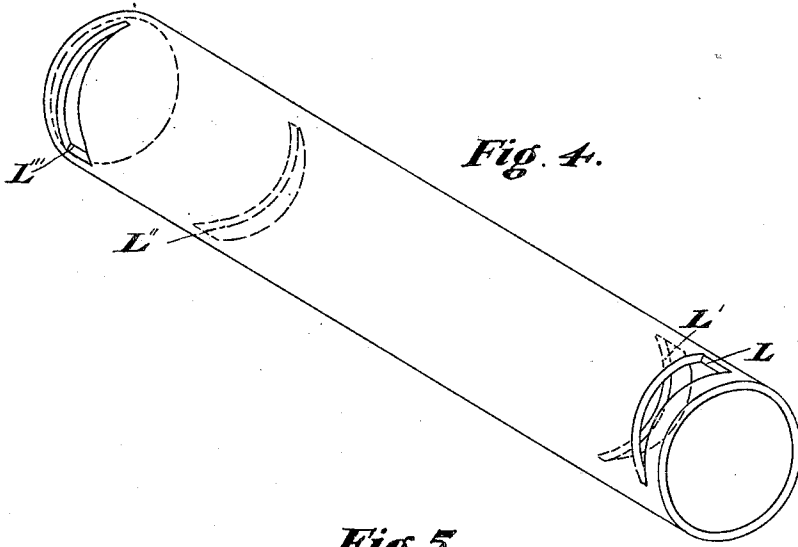

Fig. 4.

Fig. 5.

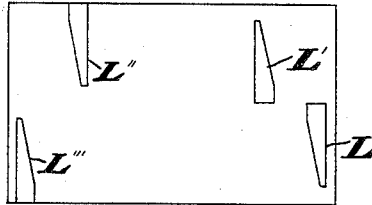
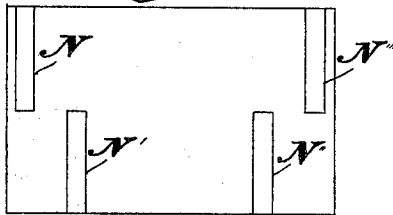

Fig. 6.



Witnesses:
Frank S. Davis.
H. L. Canby

Inventor
Isam Sedgwick
By *Robert W. Randle*
Attorney.

No. 676,801.

Patented June 18, 1901.

I. SEDGWICK.
STEAM ENGINE.

(Application filed Feb. 3, 1900.)

(No Model.)

5 Sheets—Sheet 5.

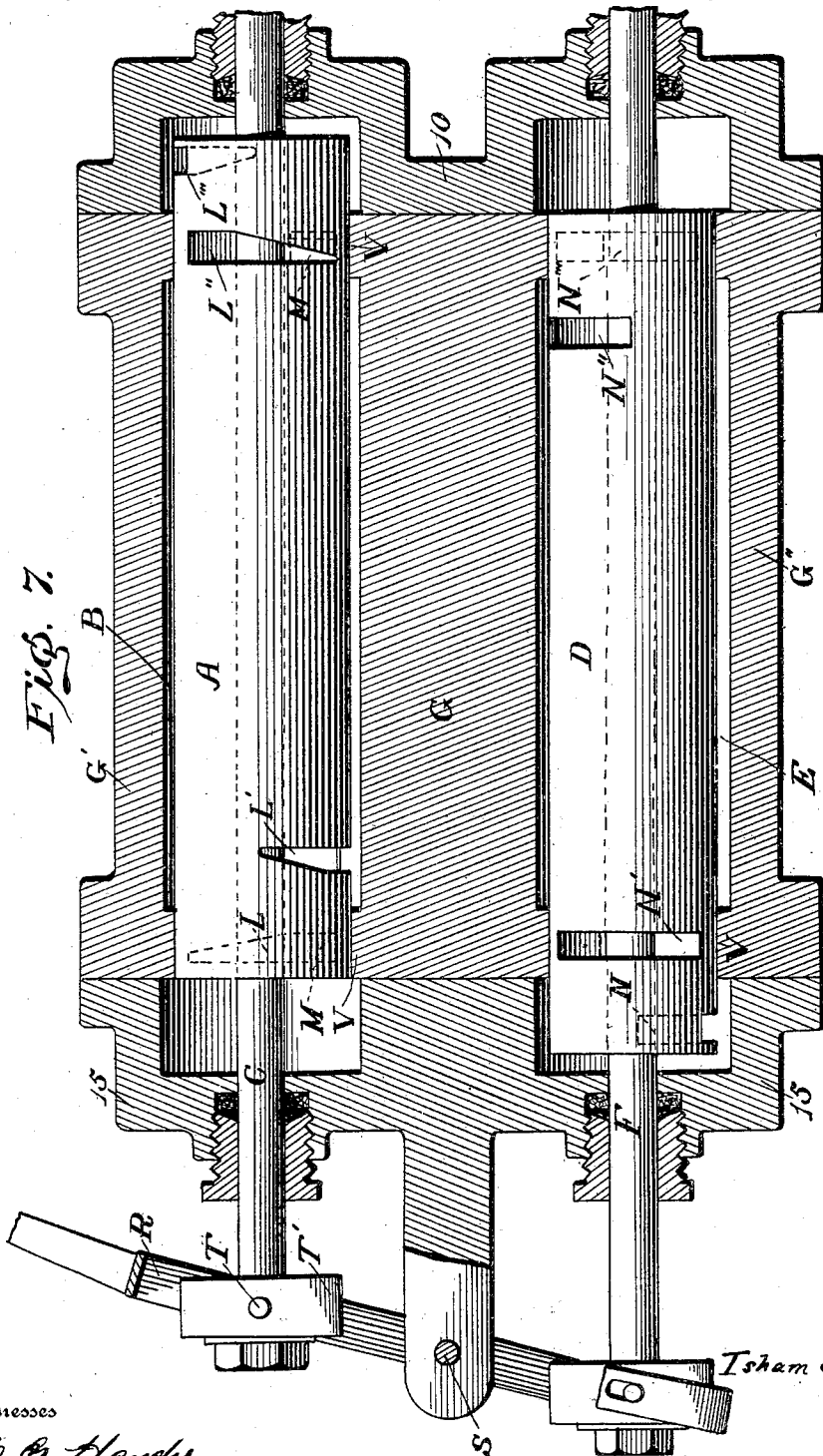

Fig. 7.

Witnesses

L. C. Handy.
P. E. Handy.

Inventor
Isham Sedgwick

By

Robert U. Randle Attorney

UNITED STATES PATENT OFFICE.

ISHAM SEDGWICK, OF RICHMOND, INDIANA.

STEAM-ENGINE.

SPECIFICATION forming part of Letters Patent No. 676,801, dated June 18, 1901.

Application filed February 3, 1900. Serial No. 3,807. (No model.)

To all whom it may concern:

Be it known that I, ISHAM SEDGWICK, a citizen of the United States, residing at Richmond, in the county of Wayne and State of Indiana, have invented new and useful Improvements in Steam-Engines, of which the following is a specification and a full, clear, and exact description of the invention, such as will enable others skilled in the art to which it appertains to make and use the same, taken in connection with the appended drawings, forming a part of this specification.

This invention relates to steam-engines; and the objects thereof are, first, to provide an improved device of this class which involves simplicity of construction and operation and in which the greatest possible efficiency or working power is secured with a minimum of steam; second, to provide a steam-engine with revolving feed and exhaust valves for controlling the operation of the engine; third, to provide a steam-engine with perfectly-balanced valves, thereby dispensing with much of the friction of an ordinary slide-valve; fourth, to provide an engine with a variable cut-off, so as to use the steam expansively or at full pressure; fifth, to provide an easy method of controlling the variable cut-off at the will of the operator or by any mechanical governor to regulate the speed; sixth, to provide an engine that is easily reversible at the will of the operator, in which reversing is accomplished by the simplest means, and, seventh, to provide a steam-engine which can be readily secured in place, cheaply manufactured, and easily operated. These and other objects not hereinbefore mentioned are accomplished by the construction illustrated in the accompanying drawings, wherein like letters and figures of reference indicate corresponding parts in all the views, and in which—

Figure 1 is an end elevation of the cylinders. Fig. 2 is a side elevation of the engine. Fig. 3 is a longitudinal sectional view of two elevations, divided by the line xx , the part shown on the right of the line xx being taken on the line zz of Fig. 1, and that part shown on the left of the line xx being taken on the line yy of Fig. 1. Fig. 4 is a detail view of the steam-valve A or the exhaust-valve D. Fig. 5 is a detail plan of the valve A, showing same opened out to show the respective locations

of the openings L. Fig. 6 is a detail plan of the exhaust-valve D, opened out to show the respective location of the ports; and Fig. 7, a vertical longitudinal section showing the valves and connecting and operating devices.

Referring now to the drawings, A represents the steam-valve balanced in the steam-chest B, mounted in the valve-seat V, the steam-valve A being provided with trapezoid openings L L' L'' L''' for the purpose of admitting steam through the ports M into the steam-space J and J' of the main cylinder or cylinders. D is of similar form and construction as A, mounted in the same manner, and provided with oblong openings for the purpose of exhausting the steam from the steam-space J and J'. Extending through and beyond and parallel with A and D are the shafts C and F, passing through the sleeves U and U' to the gears Q and Q' and geared to the spiral driving-gear P on the main shaft O.

By the above-described arrangement it can be seen that as the shaft O revolves it will cause the steam-valves to revolve also, thus admitting and discharging the steam from the main cylinders.

B is the steam-space in which revolves the steam-valve A, the live-steam inlet being shown at K, Fig. 1.

E is the steam-space in which revolves the exhaust-valve D.

The steam-valve A and the exhaust-valve D in addition to having a regular revolving motion have also an endwise motion for the purpose of regulating and controlling the admission and exhaust of the steam to and from the main cylinder. This is controlled by the lever R, Fig. 2, said lever being pivoted on the bearing S and pivoted at T to the shaft C of the steam-valve and pivoted at T'' to the shaft F of the exhaust-valve. It can be seen that as the lever is moved to the right or left it will also move the valves A and D endwise in a direction opposite to each other, and thus allow the openings therein to be directly adjacent to the ports M and N, or moved to the right or left to make the openings larger or smaller or entirely close the ports, as desired.

G and G' represent the walls of the main cylinders.

H and H' are the main piston-rods, and I I' the piston-heads.

J and J' represent the steam-space in the

main cylinders, and G'' the wall of the steam and exhaust cylinders.

10 represents the main frame of the engine.

11 represents the cross-heads.

5 12 represents the crank-plate.

13 represents the connecting-rod.

14 represents the wrist-pin, and 15 represents the cylinder-cap.

All of the figures are illustrated to show their relative positions to my improvements.

My improved engine is perfectly adapted to accomplish the results for which it is intended, and it is evident that changes in and modifications of the construction herein described may be made without departing from the spirit of my invention or sacrificing its advantages.

Having described my invention, I claim as new and desire to secure by Letters Patent—

20 1. In combination with one or more cylinders, G and G', provided with suitable piston heads and rods, of a steam-chest B adjoining the cylinder, or cylinders, a rotating steam-valve A within the steam-chest provided with trapezoid openings L, L', L'', L''', to coincide with the entry-ports M, an exhaust-valve D in the exhaust-steam chest E, shafts, C and F, extending from the steam-valve and the exhaust-valve respectively, through and beyond the sleeves U and U' to the gears Q and Q' and there geared to the driving-gear P on the main shaft O, substantially as described and shown.

2. In a steam-engine, two or more cylinders arranged parallel, a partition arranged between said cylinders, valve-chambers having their axes parallel to those of said main cylinder, one of said valve-chambers being in communication with the steam-supply and

the other with an exhaust, short direct passages from the cylinders to each valve-chamber and a valve in each of said chambers, said valves adapted to revolve, one to admit steam to the opposite ends of the cylinders alternately and the other to exhaust the steam from each end of the cylinders alternately, all as described and set forth.

3. In a steam-engine, the combination with a steam-cylinder, of cylindrical rotating steam supply and exhaust valves for said cylinder which are independent of each other, and movable in a lengthwise direction, and means for simultaneously shifting said valves lengthwise of themselves.

4. In a steam-engine the combination with a rotating steam-feed valve and a rotating exhaust-valve of an operating-lever connected to the valves whereby the valves may be given a simultaneous and opposite endwise motion to start, stop, and vary the cut-off of steam to and from the main cylinders, all as described and set forth.

5. In a steam-engine the combination with rotating steam-feed valve and rotating exhaust-valve, and means for giving them an endwise motion, of two cylinders both having their steam supply and exhaust ports controlled by the same feed-valve and exhaust-valve and valve mechanism, substantially as set forth.

In testimony whereof I have signed my name to this specification in the presence of two subscribing witnesses.

ISHAM SEDGWICK.

Witnesses:

LESLIE MCNEILL,
R. W. RANDLE.