

(19) World Intellectual Property Organization  
International Bureau



(43) International Publication Date  
10 December 2009 (10.12.2009)

(10) International Publication Number  
**WO 2009/148143 A1**

(51) International Patent Classification:  
*G03B 42/02* (2006.01) *G01T 1/29* (2006.01)  
*G03B 42/04* (2006.01)

KAISHA, 30-2, Shimomaruko 3-chome, Ohta-ku, Tokyo, 1468501 (JP).

(21) International Application Number:  
PCT/JP2009/060296

(74) Agents: **OKABE, Masao** et al.; No. 602, Fuji Bldg., 2-3, Marunouchi 3-chome, Chiyoda-ku, Tokyo 1000005 (JP).

(22) International Filing Date:  
29 May 2009 (29.05.2009)

(81) Designated States (unless otherwise indicated, for every kind of national protection available): AE, AG, AL, AM, AO, AT, AU, AZ, BA, BB, BG, BH, BR, BW, BY, BZ, CA, CH, CN, CO, CR, CU, CZ, DE, DK, DM, DO, DZ, EC, EE, EG, ES, FI, GB, GD, GE, GH, GM, GT, HN, HR, HU, ID, IL, IN, IS, KE, KG, KM, KN, KP, KR, KZ, LA, LC, LK, LR, LS, LT, LU, LY, MA, MD, ME, MG, MK, MN, MW, MX, MY, MZ, NA, NG, NI, NO, NZ, OM, PG, PH, PL, PT, RO, RS, RU, SC, SD, SE, SG, SK, SL, SM, ST, SV, SY, TJ, TM, TN, TR, TT, TZ, UA, UG, US, UZ, VC, VN, ZA, ZM, ZW.

(25) Filing Language: English

(26) Publication Language: English

(30) Priority Data:  
2008-144448 2 June 2008 (02.06.2008) JP

(71) Applicant (for all designated States except US): **CANON KABUSHIKI KAISHA** [JP/JP]; 30-2, Shimomaruko 3-chome, Ohta-ku, Tokyo, 1468501 (JP).

(72) Inventors; and

(75) Inventors/Applicants (for US only): **OKADA, Satoshi** [JP/JP]; c/o CANON KABUSHIKI KAISHA, 30-2, Shimomaruko 3-chome, Ohta-ku, Tokyo, 1468501 (JP). **INOUE, Masato** [JP/JP]; c/o CANON KABUSHIKI KAISHA, 30-2, Shimomaruko 3-chome, Ohta-ku, Tokyo, 1468501 (JP). **NAGANO, Kazumi** [JP/JP]; c/o CANON KABUSHIKI KAISHA, 30-2, Shimomaruko 3-chome, Ohta-ku, Tokyo, 1468501 (JP). **TAKEDA, Shinichi** [JP/JP]; c/o CANON KABUSHIKI KAISHA, 30-2, Shimomaruko 3-chome, Ohta-ku, Tokyo, 1468501 (JP). **SAWADA, Satoru** [JP/JP]; c/o CANON KABUSHIKI

(84) Designated States (unless otherwise indicated, for every kind of regional protection available): ARIPO (BW, GH, GM, KE, LS, MW, MZ, NA, SD, SL, SZ, TZ, UG, ZM, ZW), Eurasian (AM, AZ, BY, KG, KZ, MD, RU, TJ, TM), European (AT, BE, BG, CH, CY, CZ, DE, DK, EE, ES, FI, FR, GB, GR, HR, HU, IE, IS, IT, LT, LU, LV, MC, MK, MT, NL, NO, PL, PT, RO, SE, SI, SK, TR), OAPI (BF, BJ, CF, CG, CI, CM, GA, GN, GQ, GW, ML, MR, NE, SN, TD, TG).

Published:

— with international search report (Art. 21(3))

[Continued on next page]

(54) Title: RADIATION DETECTING APPARATUS AND RADIATION DETECTING SYSTEM

FIG. 4A

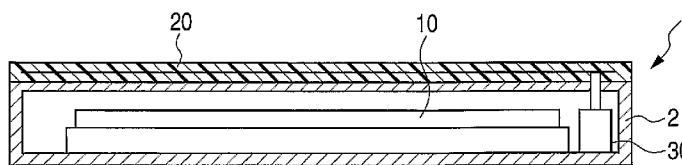
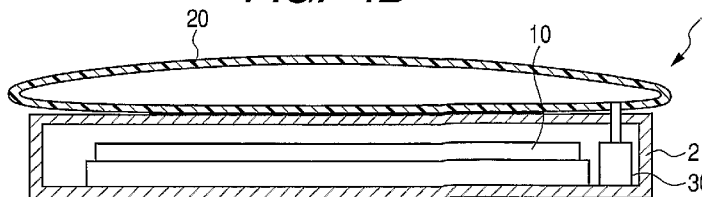

FIG. 4B



(57) Abstract: A radiation detecting apparatus includes: a sensor panel for converting radiation or light into an electric charge; a casing holding the sensor panel; an acceleration detecting unit for detecting an acceleration relating to a movement of the radiation detecting apparatus, and for transmitting a signal based on a value of the acceleration; a determining unit for determining, based on the signal transmitted from the acceleration detecting unit, as to whether the radiation detecting apparatus is in an excessively accelerated state, a free falling state or a normal state; and a buffer unit for operating to absorb a shock exerted on the radiation detecting apparatus, responsive to determination by the determining unit such that the radiation detecting apparatus is in an excessively accelerated state or a free falling state. The buffer unit is arranged outside of the casing.



WO 2009/148143 A1

- *before the expiration of the time limit for amending the claims and to be republished in the event of receipt of amendments (Rule 48.2(h))*

## DESCRIPTION

RADIATION DETECTING APPARATUS AND RADIATION DETECTING  
SYSTEM

5

## TECHNICAL FIELD

The present invention relates to a radiation detecting apparatus and a radiation detecting system.

## 10 BACKGROUND ART

Various types of digitized radiation detecting apparatuses and radiation detecting systems have been proposed and in practical use. Particularly, a compact and portable cassette type radiation detecting apparatus can be used in various scenes because of easy handling and carrying.

However, the cassette type radiation detecting apparatus uses a sensor panel of glass for detecting incident radiation and may break due to a shock such as falling. Thus, there is a need for a radiation detecting apparatus resistant to shock and with high safety. To solve the above problem, various cassette type radiation detecting apparatuses have been studied and developed.

For example, U.S. Patent Application Publication No. 2004/0252613 (corresponding to Japanese Patent Application Laid-Open No. 2005-003755) proposes an image information detecting cassette that stops supply of electric power when

25

the image information detecting cassette falls and breaks due to a shock to increase safety of an operator.

U.S. Patent Application Publication No. 2005/0017188 (corresponding to Japanese Patent Application Laid-Open No. 5 2004-361879) proposes a radiation detecting cassette in which a casing holding a solid-state radiation detector is constituted by an outer shell, an inner shell, and a restraining member for restraining a movement of the inner shell with respect to the outer shell to increase 10 resistance to shock.

#### DISCLOSURE OF THE INVENTION

However, the radiation detecting apparatus described in U.S. Patent Application Publication No. 2004/0252613 15 (corresponding to Japanese Patent Application Laid-Open No. 2005-003755) can detect breakage of the radiation detecting apparatus, but cannot reduce the possibility of breakage at a time of falling of the radiation detecting apparatus. The radiation detecting apparatus described in U.S. Patent 20 Application Publication No. 2005/0017188 (corresponding to Japanese Patent Application Laid-Open No. 2004-361879) includes the outer shell, the inner shell, and a shock absorber provided between the outer shell and the inner shell, and this inevitably increases the size of the 25 radiation detecting apparatus.

In view of the above problems, the present invention has an object to provide a radiation detecting apparatus

that can prevent an increase in the size of the radiation detecting apparatus, and can reduce the possibility of breakage when a shock such as falling is exerted on the radiation detecting apparatus.

5           A first aspect of the present invention relates to a radiation detecting apparatus comprising:

          a sensor panel for converting radiation of light into an electric charge;

          a casing holding the sensor panel;

10           an acceleration detecting unit for detecting an acceleration relating to a movement of the radiation detecting, and for transmitting a signal based on a value of the acceleration;

          a determining unit for determining, based on a comparing, with a reference value, the signal transmitted from the acceleration detecting unit, as to whether the radiation detecting apparatus is in a normal state or not;

15           a buffer unit, arranged out side of the casing, for operating to absorb a shock exerted on the radiation detecting apparatus, responsive to determination by the determining unit such that the signal transmitted from the acceleration detecting unit exceeds the reference value.

          A second aspect of the present invention relates to a radiation detecting system including at least: a radiation detecting apparatus; a signal processing unit for  
25           processing a signal derived from the radiation detecting apparatus; and a radiation source generating the radiation.

According to the present invention, it is possible to suppress an undesirable increasing a size of the radiation detecting apparatus, and to reduce a risk of damaging the radiation detecting apparatus due to a shock at a time of a falling the radiation detecting apparatus.

Other features and advantages of the present invention will be apparent from the following description taken in conjunction with the accompanying drawings, in which like reference characters designate the same or similar parts throughout the figures thereof.

#### BRIEF DESCRIPTION OF THE DRAWING

FIG. 1 is an appearance view of an embodiment of a radiation detecting apparatus according to the present invention.

FIG. 2 is a circuit block diagram of the embodiment of the radiation detecting apparatus according to the present invention.

FIG. 3 is a flowchart illustrating an operation of the radiation detecting apparatus in FIGS. 1 and 2.

FIGS. 4A and 4B are schematic views of a radiation detecting apparatus using an air bag as a buffer unit.

FIGS. 5A and 5B are schematic views of a radiation detecting apparatus using, as a buffer unit, a surface member formed from CFRP and a coil spring.

FIGS. 6A and 6B are schematic views of a radiation detecting apparatus using, as a buffer unit, a surface

member formed from CFRP and a shock absorber using a gas pressure.

FIGS. 7A and 7B are schematic views of a radiation detecting apparatus using, as a buffer unit, a surface member formed from sheet shaped polyurethane fiber and a plate spring.

FIG. 8 is a schematic view of an embodiment of a radiation detecting system including a radiation detecting apparatus according to the present invention.

10

#### BEST MODES FOR CARRYING OUT THE INVENTION

Now, an embodiment of a radiation detecting apparatus according to the present invention will be described in detail with reference to the drawings.

FIG. 1 is an appearance view of an embodiment of a radiation detecting apparatus according to the present invention. FIG. 2 is a circuit block diagram of the embodiment of the radiation detecting apparatus according to the present invention.

The radiation detecting apparatus 1 of the embodiment includes a casing 2 having a handle 5. The casing 2 includes at least a sensor panel 10, a control circuit portion 11, and a battery 18 for supplying electric power to the control circuit portion 11. The control circuit portion 11 includes a drive circuit 12 of the sensor panel 10, a read out circuit 13 of a signal derived from the sensor panel 10, and a control portion connected to the

drive circuit 12 and the read out circuit 13.

Further, the control circuit portion 11 includes a determining unit 19 for determining a state of the radiation detecting apparatus 1. Specifically, the determining unit 19 determines, based on a signal transmitted from an acceleration detecting unit described later, whether the radiation detecting apparatus 1 in moving is in an excessively accelerated state, a free falling state or a normal state. The determining unit 19 includes a circuit such as a comparator. The comparator compares a preset signal with a signal transmitted by an acceleration detecting means, and outputs a different value by a result of the comparing.

Further, to the control circuit portion 11, an acceleration detecting unit (acceleration sensor 14), a memory 15, and a buffer unit 16 for operating according to a signal from the determining unit 19 are connected. The acceleration sensor 14 has a function of detecting an acceleration relating to the movement of the radiation detecting apparatus 1, and transmitting a signal based on a value of the acceleration to the determining unit 19. The memory 15 stores a value of a criterion used when the determining unit 19 determines the state of the radiation detecting apparatus 1, and the determining unit 19 compares the criterion value with the obtained value of the acceleration for determination. The buffer unit 16 is a member for protecting the radiation apparatus 1 from a

shock such as falling. The buffer unit 16 will be described later in more detail.

Further, to the control circuit portion 11, a state display unit 3 for displaying that the buffer unit 16 operates according to the signal from the determining unit 19, and a holding switch 4 for holding the operating buffer unit 16 in the radiation detecting apparatus 1 are connected. The state display unit 3 and the holding switch 4 can be provided, for example, on the handle 5 as in FIG. 1 so as to be externally checked and operated. As the state display unit 3, an LED or a liquid crystal display apparatus can be used. Further, to the control circuit portion 11, a communication unit 17 for transmitting and receiving data to and from an external device is connected. As the communication unit 17, an external connection terminal is placed in the casing 2 with wires, and a transmitting and receiving circuit including an antenna is placed in the casing 2 without wires.

The battery 18 supplies electric power to the control circuit portion 11 and the components connected to the control circuit portion 11.

As the sensor panel 10, an indirect conversion type sensor panel can be used in which a plurality of pixels having photoelectric conversion elements and TFTs is placed on a glass substrate, and that detects light converted from radiation into visible light by a scintillator.

Alternatively, a direct conversion type sensor panel can be

used in which a TFT array is placed on a glass substrate, and that converts radiation into an electric charge with a-Se of the TFT array. The radiation refers to X-ray,  $\alpha$ -ray,  $\beta$ -ray, and  $\gamma$ -ray.

5 As the acceleration detecting unit (acceleration sensor 14), a general MEMS acceleration sensor of a piezoresistance type, capacitance type, or heat detection type can be used.

The buffer unit 16 is provided on an outer surface of  
10 the casing 2 of the radiation detecting apparatus 1, and is a member for expanding outward to absorb a shock. An example is an air bag. Another example is a buffer unit including a surface member that first comes into contact with a floor at a time of falling, and an elastic member  
15 such as an oil or gas pressure or a spring for lessening a shock. The surface member can be formed from plastic or metal, and desirably formed from light and strong CFRP or KFRP. The surface member can be also formed from a sheet shaped stretch material of synthetic fiber such as nylon,  
20 aramid and polyurethane. The elastic member is used for further lessening a shock at a time of falling, and selected from a shock absorber using a gas or oil pressure, an air bag, a rubber, a coil spring, and a plate spring.

When the buffer unit 16 is placed on a radiation  
25 incident side of the radiation detecting apparatus 1, the buffer unit 16 can be adjusted in its material and thickness so as to easily transmit radiation. For example,

a surface member formed from aluminum having a thickness of 100  $\mu\text{m}$  transmits 90% of X-ray of 50 keV. The transmittance of the X-ray is calculated by the following expression.

$$I-I_0 = \exp(-\mu T)$$

5 (where I is intensity of X-ray incident on a test specimen,  $I_0$  is intensity of the X-ray after passing through the test specimen,  $\mu$  is an absorption coefficient, and T is a thickness of the test specimen.)

The buffer unit can be formed from a material with  
10 little effect on an image such as an artifact. For example, the buffer unit can be formed from CFRP, KFRP, and a sheet shaped stretch material of synthetic fiber such as nylon, aramid and polyurethane. Further, the buffer unit can have a structure with small surface distribution such as a  
15 uniform thickness.

Next, a flow of operations of the above described components of the radiation detecting apparatus will be described.

FIG. 3 is a flowchart illustrating an operation of  
20 the radiation detecting apparatus in FIGS. 1 and 2.

First, in Step 101, it is determined whether the radiation detecting apparatus 1 is connected (mounted) to the other device such as a C arm or a frame for an standing or recumbent position. The C arm is an apparatus having a  
25 C-shaped rotatable holder mainly for radiographing of X-ray moving images, and an X-ray source is fixed to one end of the C-shaped holder and the detecting apparatus is fixed to

the other end. The determining unit 19 in the control circuit portion 11 determines the connection via the communication unit 17 in the radiation detecting apparatus, for example, from a signal transmitted from an external PC and indicating a connection state. With such connection, the radiation detecting apparatus 1 has a low possibility of breakage due to falling, and thus it is determined that the radiation detecting apparatus 1 is in a preset normal state, and the process proceeds to Step 106. Without the connection, the process proceeds to Step 102.

In Step 102, it is determined whether the radiation detecting apparatus 1 is in an excessively accelerated state. The determining unit 19 determines whether a value of an acceleration of the radiation detecting apparatus 1 obtained from the acceleration detecting unit (acceleration sensor 14) is in an excessively accelerated state (state with an acceleration higher than 1 G). When a signal higher than 1 G is input to the determining unit 19, the determining unit 19 determines that the value is in the excessively accelerated state, the process proceeds to Step 103, and the buffer unit 16 operates. When the acceleration is 1 G or lower, the process proceeds to Step 104.

In Step 104, it is determined whether the radiation detecting apparatus 1 is in a free falling state. Whether the radiation detecting apparatus 1 is in the free falling state is determined based on a gravity acceleration and a

time thereof. For example, a case where a microgravity state lasts for 0.26 seconds is regarded as free falling. This is because when a falling height of the radiation detecting apparatus 1 provided on a bed in a recumbent position is about 35 cm, a falling time of the radiation detecting apparatus 1 is 0.27 seconds. In this case, the determining unit 19 determines that the radiation detecting apparatus 1 is in the free falling state when the microgravity state lasts for 0.26, the process proceeds to Step 105, and the buffer unit 16 operates. Otherwise, it is determined that the radiation detecting apparatus 1 is in the normal state, and the process proceeds to Step 106 described above and then returns to Step 101. The values of the criterion height and falling time are not limited to the above described values but can be selected by a user because a placement position of the radiation detecting apparatus may differ according to the state of use of the apparatus.

The values for determination criteria in Steps 102 and 104 are stored in a memory of the determining unit 19 itself, or used by the determining unit 19 reading data stored in the memory 15 connected to the control circuit portion 11.

When it is determined by the above described determination flow that the radiation detecting apparatus 1 is in the excessively accelerated state or the free falling state, the control circuit portion 11 sends a signal for

operating the buffer unit 16. Thus, the buffer unit 16 operates so as to protect the radiation apparatus 1. When it is determined by the above described determination flow that the radiation detecting apparatus 1 is in the normal state, the control circuit portion 11 does not send a signal to the buffer unit 16.

Next, various embodiments of the buffer unit 16 will be described in detail.

FIGS. 4A and 4B illustrate a radiation detecting apparatus including an air bag module as a buffer unit. The air bag module includes an air bag 20 and an inflator 30. The inflator 30 provides a gas into the air bag 20, and the air bag 20 is inflated by the gas provided by the inflator 30. FIG. 4A illustrates the radiation detecting apparatus in a normal state. When it is determined that the radiation detecting apparatus is in an excessively accelerated state or a free falling state, the control circuit portion sends a signal to the air bag module as the buffer unit, the inflator 30 provides a gas into the air bag 20 to inflate the air bag 20 as illustrated in FIG. 4B to absorb a shock. FIGS. 4A and 4B illustrate an example where the air bag 20 is placed on one surface of the radiation detecting apparatus, but providing air bags 20 on all surfaces increases safety. An air bag 20 inflated so as to have a thickness larger than a thickness of the apparatus can be desirably provided at a corner of the radiation detecting apparatus in FIG. 1 because of little

effect on radiation use efficiency and images.

FIGS. 5A and 5B illustrate a radiation detecting apparatus using, as a buffer unit, a surface member 21 formed from CFRP (carbon fiber reinforced plastic) and an elastic member formed of a coil spring 22. FIG. 5A illustrates a corner of the radiation detecting apparatus in a normal state with a metal spring being contracted and fixed by a fixing unit 23. As the fixing unit 23, a mechanical unit such as a hook combined with a cam or a magnetic unit such as a magnet is used. An electromagnetic unit such as a solenoid for holding with an attracting force of a permanent magnet can be used, and the solenoid when used can also serve as an elastic member. When it is determined whether the radiation detecting apparatus is in an excessively accelerated state or a free falling state, the control circuit portion sends a signal to the buffer unit, the fixing unit is opened as in FIG. 5B, and the coil spring 22 extends to absorb a shock.

FIGS. 6A and 6B illustrate a radiation detecting apparatus using, as a buffer unit, a surface member 21 formed from CFRP and an elastic member formed of a shock absorber 24 using a gas pressure. FIG. 6A illustrates a corner of the radiation detecting apparatus in a normal state with the gas pressure being reduced and the shock absorber 24 being contracted and fixed by a fixing unit 23. When it is determined that the radiation detecting apparatus is in an excessively accelerated state or a free

falling state, the control circuit portion sends a signal to the buffer unit, the fixing unit is opened as illustrated in FIG. 6B, and the gas pressure is applied to the shock absorber to absorb a shock at a time of falling.

5           FIGS. 7A and 7B illustrate a radiation detecting apparatus using, as a buffer unit, a surface member 25 formed from sheet shaped polyurethane fiber and an elastic member formed of a plate spring 26. FIG. 6A illustrates a cross section of the radiation detecting apparatus in a  
10 normal state with the plate spring 26 being deformed and fixed by a fixing unit (not shown). When it is determined that the radiation detecting apparatus is in an excessively accelerated state or a free falling state, the control  
circuit portion sends a signal to the buffer unit, the  
15 fixing unit is opened as illustrated in FIG. 7B, and the plate spring 26 expands the surface member 25 formed from the sheet shaped polyurethane fiber to absorb a shock.

In any of the radiation detecting apparatuses in FIGS. 4A to 7B, the buffer unit can be provided in any portions  
20 beside the corner and the radiation incident side of the radiation detecting apparatus.

With a mechanism for automatically restoring the operated buffer unit, the buffer unit can be restored in conjunction with the holding switch 4 in FIG. 1. For  
25 example, using a solenoid as a lock mechanism allows the buffer unit to be restored by controlling a current flowing through a coil of the solenoid. The present invention is

not limited to the detailed examples in FIGS. 4A to 7B, and configurations can be combined that can prevent an increase in the size of the radiation detecting apparatus and reduce the possibility of breakage when a shock such as falling is  
5 exerted on the radiation detecting apparatus.

Finally, an embodiment of a radiation detecting system using the above described radiation detecting apparatus of the present invention will be described with reference to FIG. 8.

10 X-ray 6060 generated by a radiation source 6050 passes through the chest 6062 to be observed of a patient or a human subject 6061, and enters a radiation detecting apparatus 6040 including a sensor panel having a scintillator and a photoelectric conversion element. The  
15 entering X-ray includes information on the inside of the body of the human subject 6061. The scintillator emits light in response to the entry of the X-ray, and photoelectrically converts the light to obtain electrical information. The information is converted into digital  
20 form, subjected to an image processing by an image processor 6070 as a signal processing unit, and can be observed on a display 6080 as a display unit in a control room.

The information can be transferred to a remote place  
25 by a transmission processing unit such as a telephone line 6090, and be displayed on a display 6081 as a display unit in a doctor room in a different place or stored in a

recording unit such as an optical disk. This allows diagnosis by a doctor in a remote place. Also, a film processor 6100 as a recording unit can record the information in a film 6110 as a recording medium.

5           In such a radiation detecting system, when the determining unit 19 in the radiation detecting apparatus determines that the radiation detecting apparatus is in an excessively accelerated state or a free falling state, the communication unit 17 sends a signal to a signal processing  
10 unit or a radiation source with or without wires to control so that the radiation source does not emit X-ray. This can prevent emission of the X-ray when there is a problem in the radiation detecting apparatus and increases safety.

#### 15 INDUSTRIAL APPLICABILITY

As describe above, the present invention can be applied to a medical digital X-ray detecting apparatus, and can be also effectively applied to a digital radiation detecting apparatus for non-destructive inspection or other  
20 uses with radiation.

While the present invention has been described with reference to exemplary embodiments, it is to be understood that the invention is not limited to the disclosed  
25 exemplary embodiments. The scope of the following claims is to be accorded the broadest interpretation so as to encompass all such modifications and equivalent structures

and functions.

This application claims the benefit of Japanese Patent Application No. 2008-144448, filed June 2, 2008, which is hereby incorporated by reference herein in its entirety.

## CLAIMS

1. A radiation detecting apparatus comprising:  
a sensor panel for converting radiation of light into  
5 an electric charge;  
a casing holding the sensor panel;  
an acceleration detecting unit for detecting an  
acceleration relating to a movement of the radiation  
detecting, and for transmitting a signal based on a value  
10 of the acceleration;  
a determining unit for determining, based on a  
comparing, with a reference value, the signal transmitted  
from the acceleration detecting unit, as to whether the  
radiation detecting apparatus is in a normal state or not;  
15 a buffer unit, arranged out side of the casing, for  
operating to absorb a shock exerted on the radiation  
detecting apparatus, responsive to determination by the  
determining unit such that the signal transmitted from the  
acceleration detecting unit exceeds the reference value.
- 20 2. The radiation detecting apparatus according to  
claim 1, wherein  
the buffer unit is an air bag.
3. The radiation detecting apparatus according to  
claim 1, wherein  
25 the buffer unit comprises at least a surface member  
arranged outside of the casing so that the shock exerts on  
the surface member firstly at a time of falling; and an

elastic member arranged between the surface member and the casing.

4. The radiation detecting apparatus according to claim 3, wherein

5 the surface member is formed from a material selected from plastic, metal, CFRP, KFRP, and a sheet shaped stretch material of synthetic fiber, and the elastic member is one selected from a shock absorber using an gas or oil pressure, an air bag, a rubber, a coil spring, and a plate spring.

10 5. The radiation detecting apparatus according to claim 1, wherein

the buffer unit is placed on one or more planes of the casing.

15 6. The radiation detecting apparatus according to claim 1, wherein

the buffer unit is placed on a corner of the casing.

7. A radiation detecting system comprising at least:

20 a radiation detecting apparatus according to claim 1;  
a signal processing unit for processing a signal derived from the radiation detecting apparatus; and  
a radiation source generating the radiation.

8. The radiation detecting system according to claim 7, wherein

25 responsive to determination by the determining unit such that the radiation detecting apparatus is in the excessively accelerated state or the free falling state,

the radiation source is controlled by a transmitting unit provided in the radiation detecting apparatus to as not to generate the radiation.

9. The radiation detecting apparatus according to  
5 claim 1, wherein

the determining unit determines, based on a comparing, with the reference value, the signal transmitted from the acceleration detecting unit, as to whether the radiation detecting apparatus is in an excessively accelerated state,  
10 or a normal state, and

the buffer unit operates to absorb the shock exerted on the radiation detecting apparatus, responsive to determination by the determining unit such that the radiation detecting apparatus is in the excessively  
15 accelerated state.

10. The radiation detecting apparatus according to claim 1, wherein

the determining unit determines, based on a comparing, with the reference value, the signal transmitted from the  
20 acceleration detecting unit, as to whether the radiation detecting apparatus is in a free falling state, or a normal state, and

the buffer unit operates to absorb the shock exerted on the radiation detecting apparatus, responsive to  
25 determination by the determining unit such that the radiation detecting apparatus is in the free falling state.

**FIG. 1**

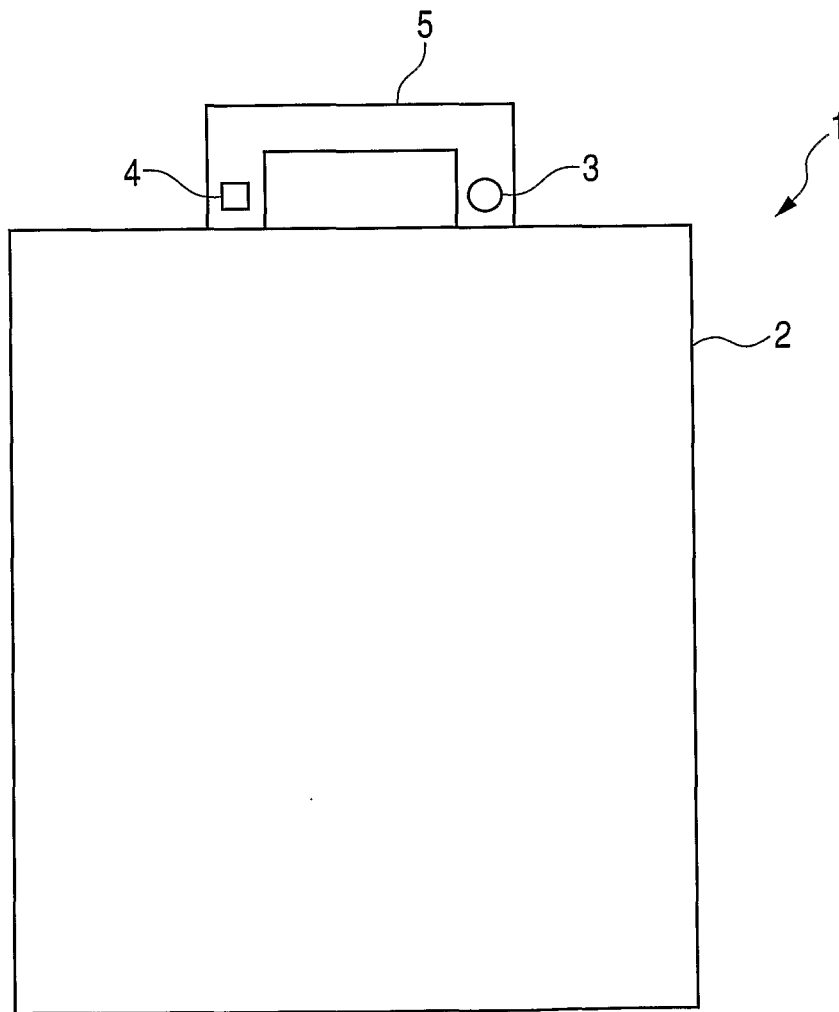
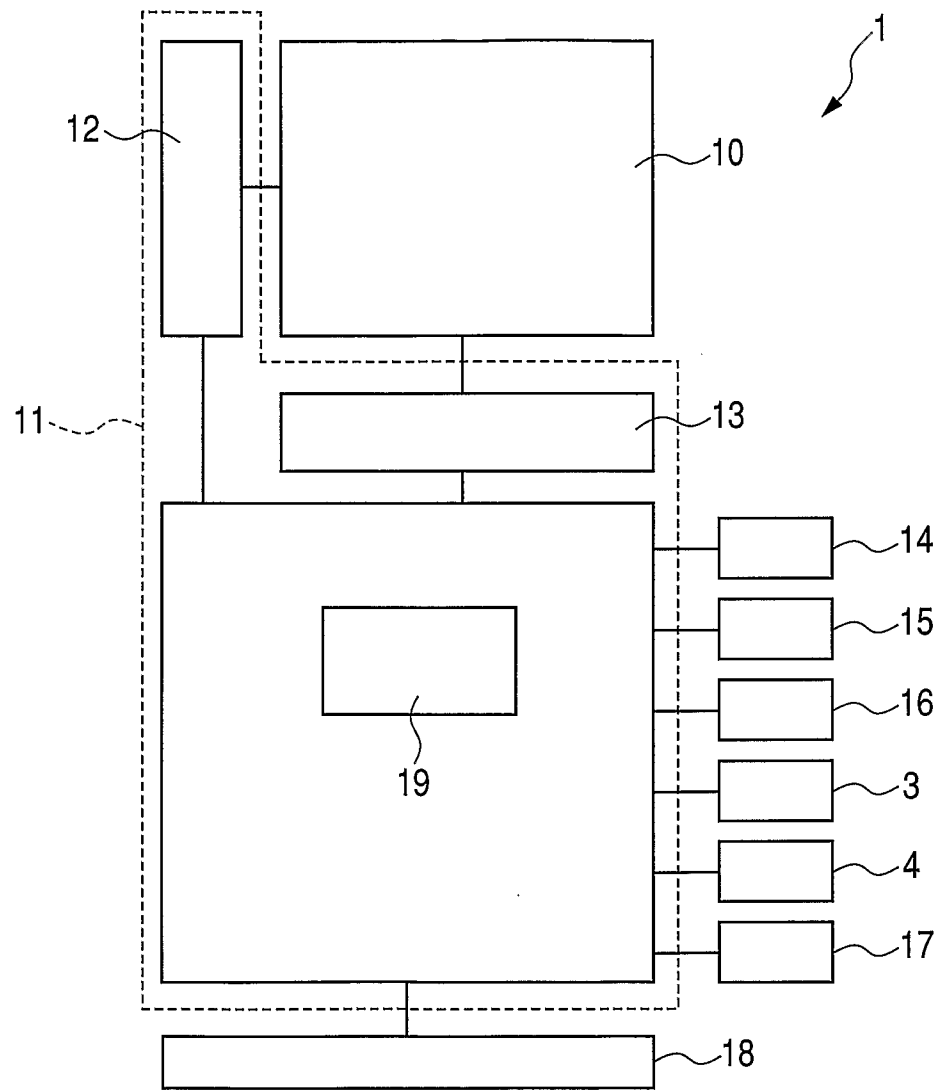
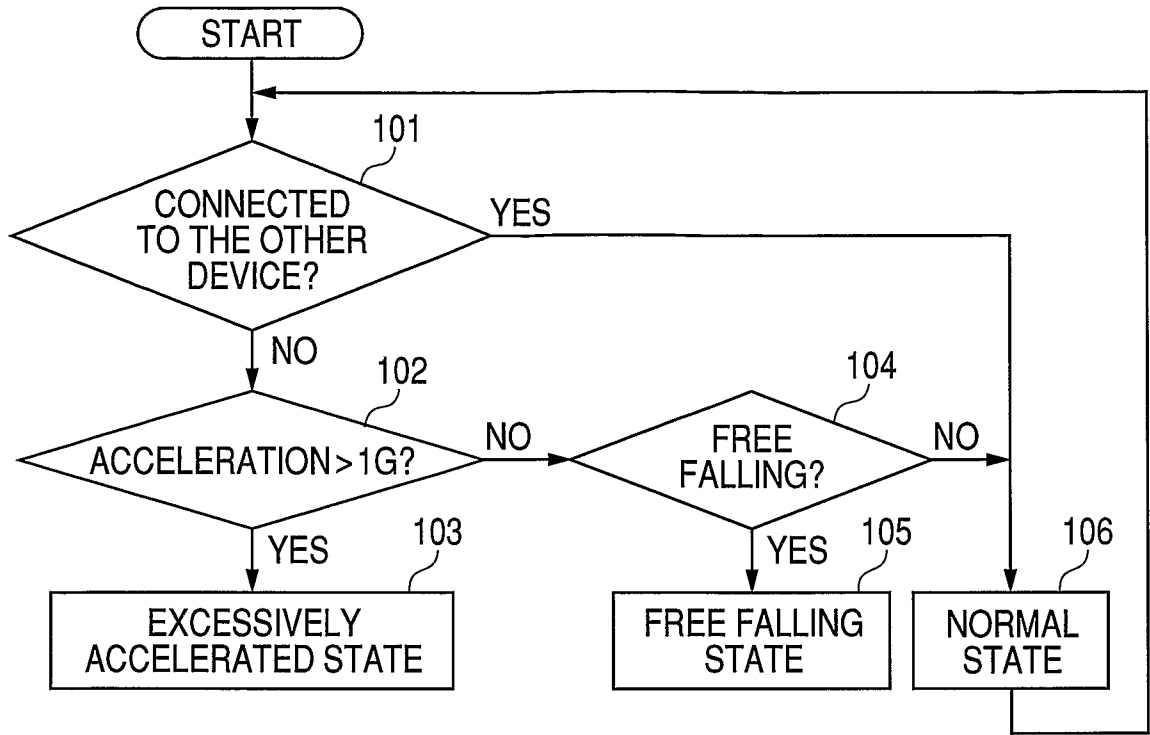

FIG. 2



**FIG. 3**



**FIG. 4A**

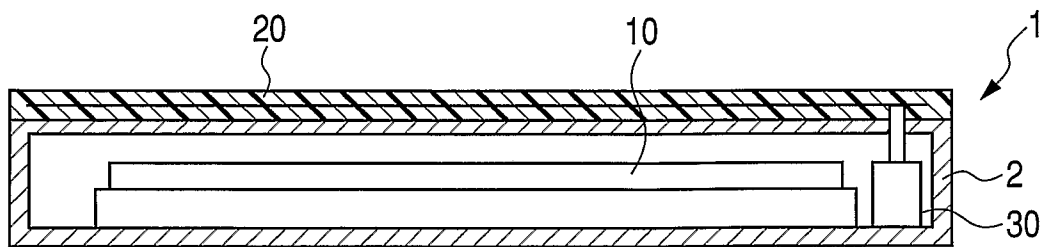

**FIG. 4B**

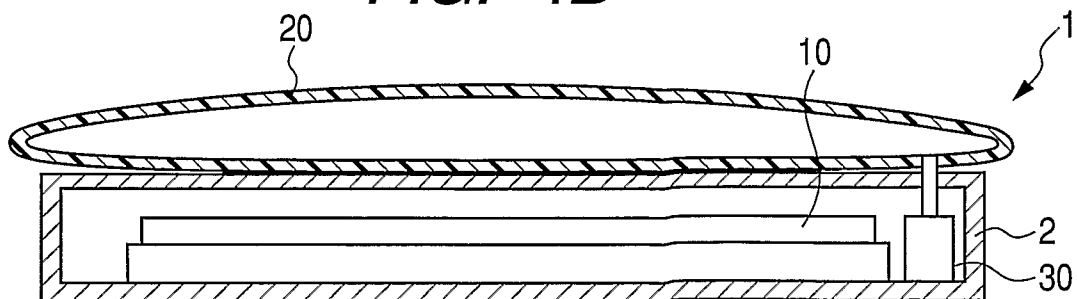

FIG. 5A

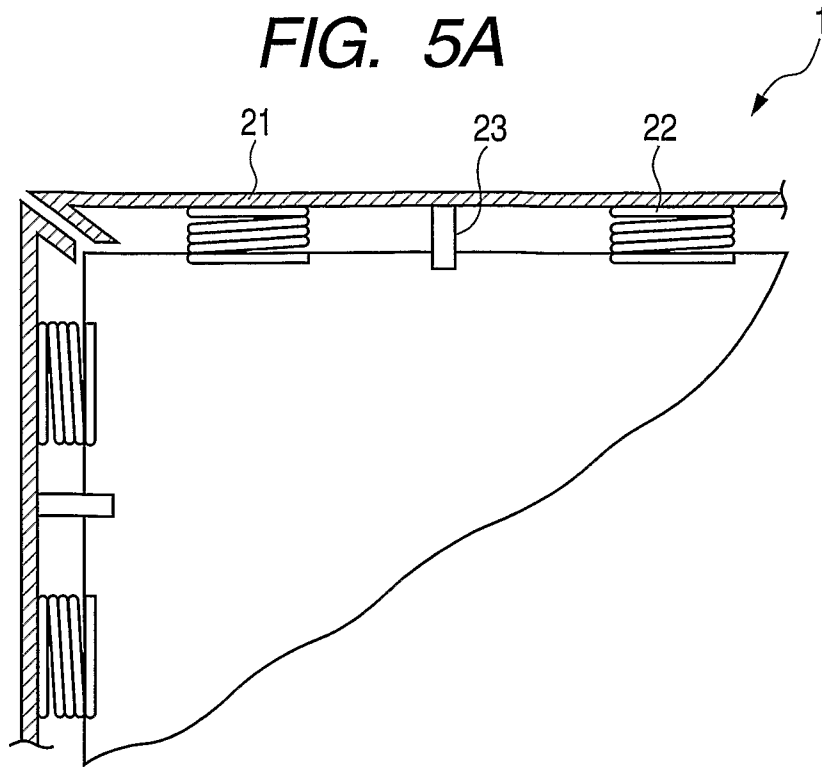

FIG. 5B

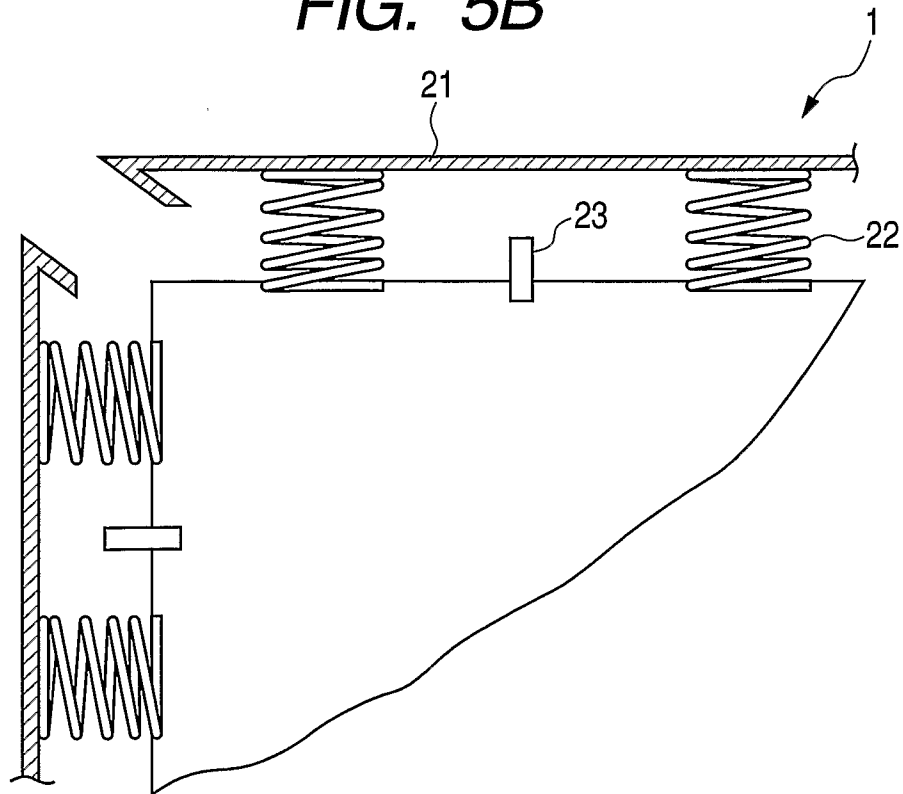

FIG. 6A

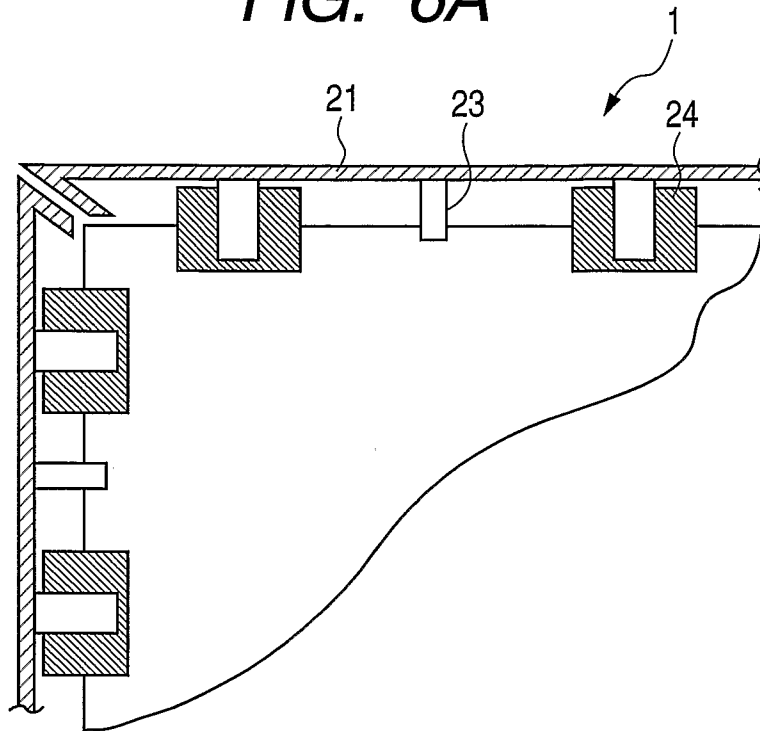
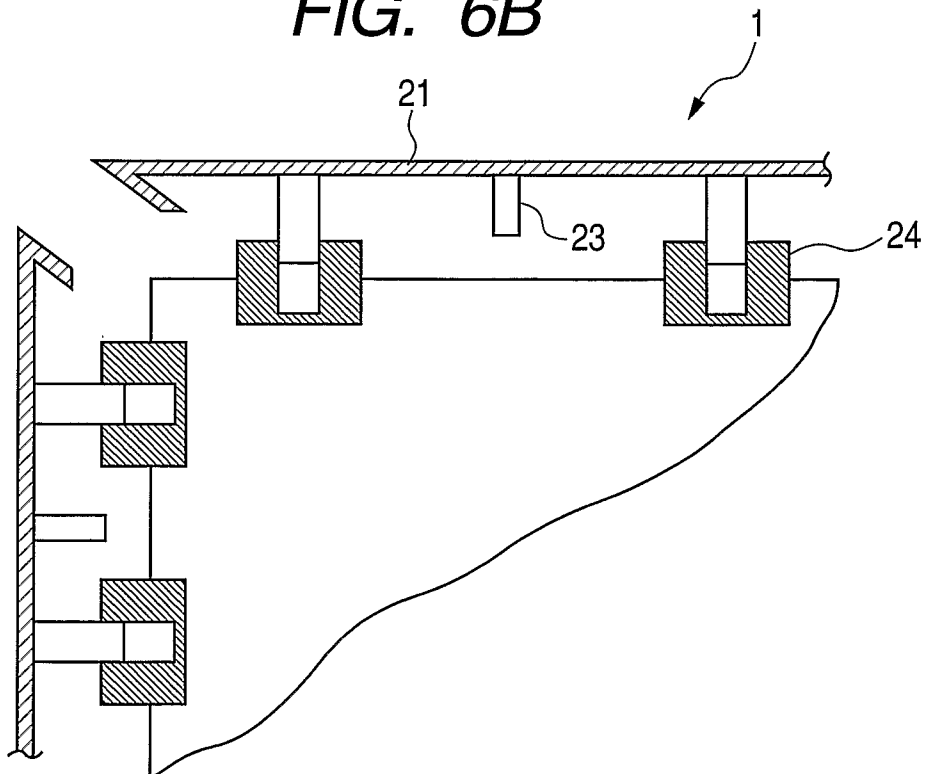

FIG. 6B



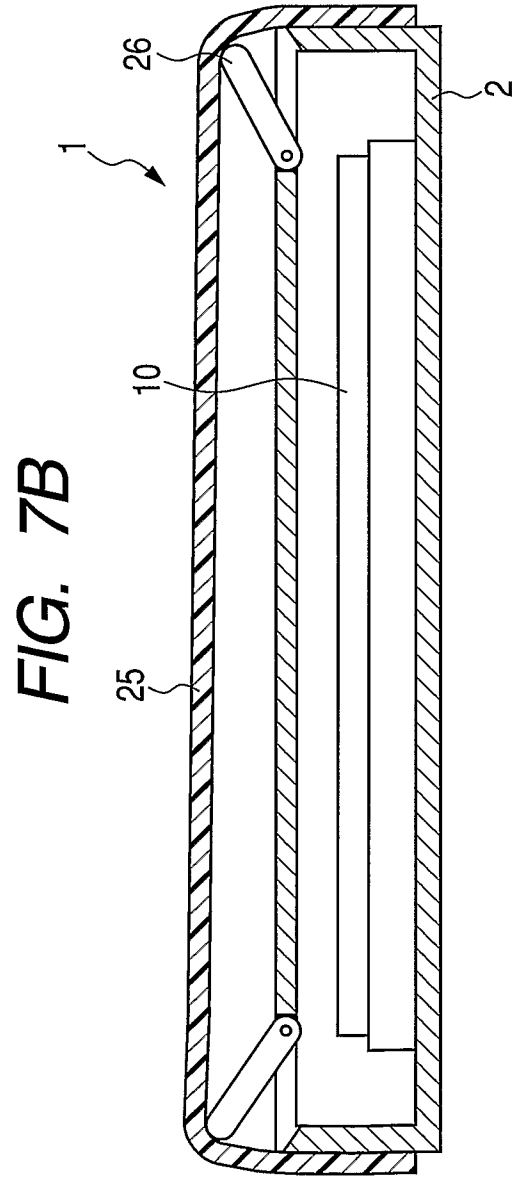
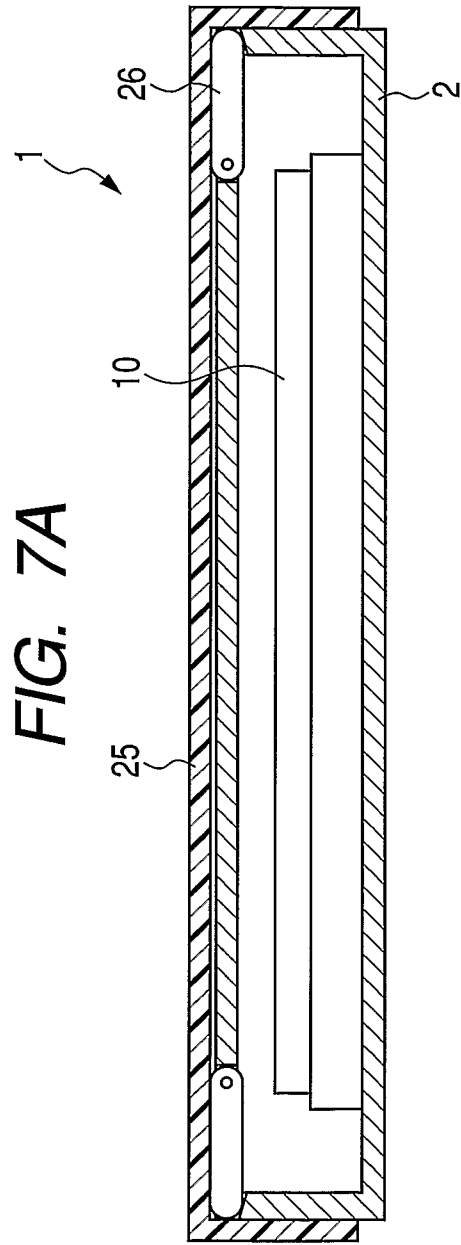
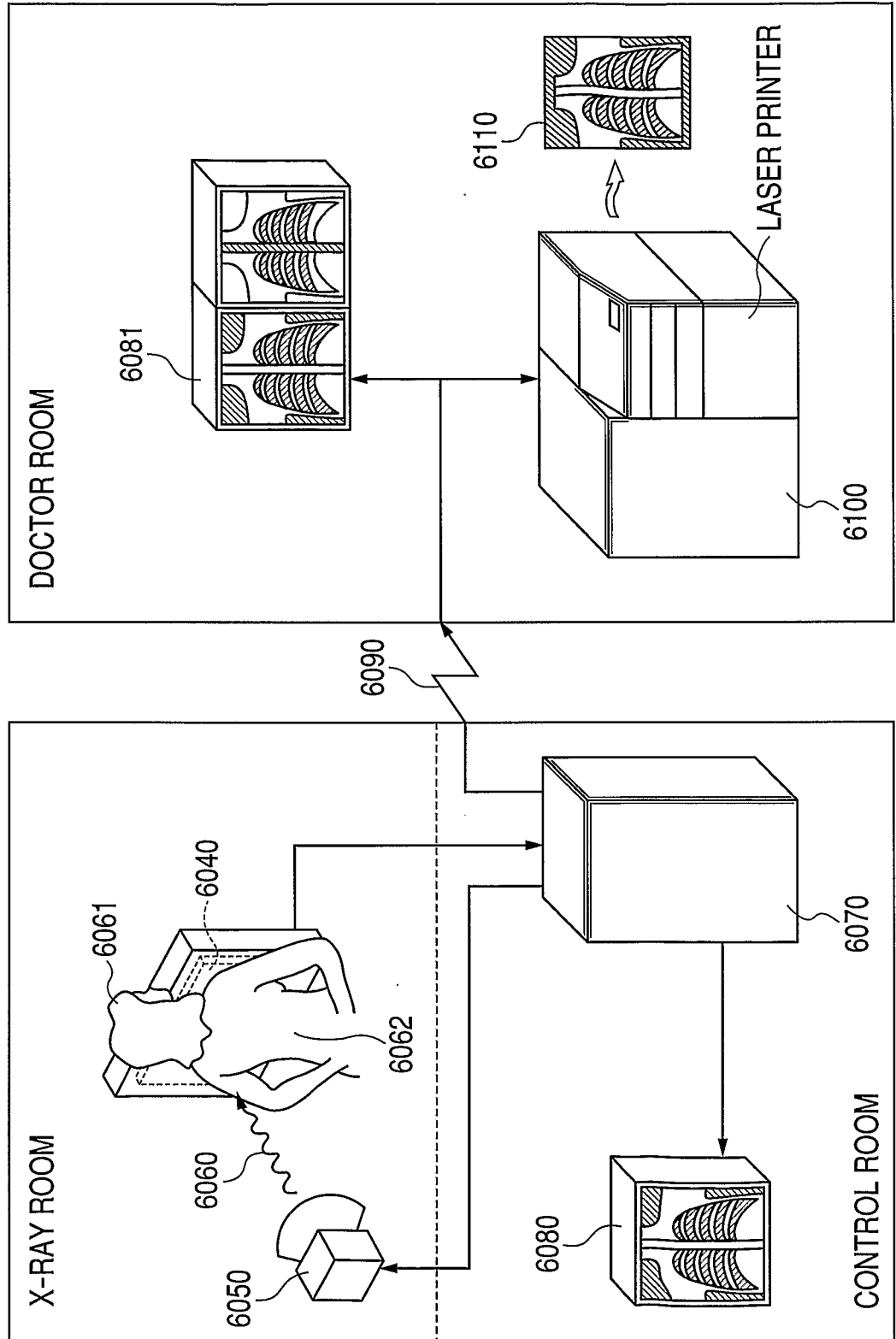

FIG. 8



## INTERNATIONAL SEARCH REPORT

International application No

PCT/JP2009/060296

## A. CLASSIFICATION OF SUBJECT MATTER

INV. G03B42/02 G03B42/04 G01T1/29

According to International Patent Classification (IPC) or to both national classification and IPC

## B. FIELDS SEARCHED

Minimum documentation searched (classification system followed by classification symbols)

G03B G01T

Documentation searched other than minimum documentation to the extent that such documents are included in the fields searched

Electronic data base consulted during the international search (name of data base and, where practical, search terms used)

## C. DOCUMENTS CONSIDERED TO BE RELEVANT

Category*	Citation of document, with indication, where appropriate, of the relevant passages	Relevant to claim No.
Y	US 2006/267779 A1 (ISHIKAWA MURIEL Y [US] ET AL ISHIKAWA MURIEL Y [US] ET AL) 30 November 2006 (2006-11-30) paragraphs [0049] - [0054], [0062], [0087] - [0089], [0134], [0135]; figures 24,25	1-6,8-10
Y	US 2007/085015 A1 (CASTLEBERRY DONALD E [US]) 19 April 2007 (2007-04-19) paragraphs [0001], [0011], [0035], [0036]	1-6,8-10
A	WO 2008/054717 A (CARESTREAM HEALTH INC [US]; HEATH MICHAEL D [US]; LO YAWCHENG [US]; LE) 8 May 2008 (2008-05-08) pages 1-6	7
	----- -/--	

 Further documents are listed in the continuation of Box C. See patent family annex.

\* Special categories of cited documents:

- \*A\* document defining the general state of the art which is not considered to be of particular relevance
- \*E\* earlier document but published on or after the international filing date
- \*L\* document which may throw doubts on priority claim(s) or which is cited to establish the publication date of another citation or other special reason (as specified)
- \*O\* document referring to an oral disclosure, use, exhibition or other means
- \*P\* document published prior to the international filing date but later than the priority date claimed

- \*T\* later document published after the international filing date or priority date and not in conflict with the application but cited to understand the principle or theory underlying the invention
- \*X\* document of particular relevance; the claimed invention cannot be considered novel or cannot be considered to involve an inventive step when the document is taken alone
- \*Y\* document of particular relevance; the claimed invention cannot be considered to involve an inventive step when the document is combined with one or more other such documents, such combination being obvious to a person skilled in the art.
- \*G\* document member of the same patent family

Date of the actual completion of the international search

21 September 2009

Date of mailing of the international search report

30/09/2009

Name and mailing address of the ISA/

European Patent Office, P.B. 5818 Patentlaan 2  
NL - 2280 HV Rijswijk  
Tel. (+31-70) 340-2040,  
Fax: (+31-70) 340-3016

Authorized officer

Rückerl, Ralph

## INTERNATIONAL SEARCH REPORT

International application No

PCT/JP2009/060296

C(Continuation). DOCUMENTS CONSIDERED TO BE RELEVANT

Category*	Citation of document, with indication, where appropriate, of the relevant passages	Relevant to claim No.
A	US 2006/212986 A1 (MAHONEY JEROME R [US]) 28 September 2006 (2006-09-28) abstract; figures 1-4 -----	1
Y	US 2003/160196 A1 (YASUDA HIROAKI [JP] ET AL) 28 August 2003 (2003-08-28) abstract -----	1

# INTERNATIONAL SEARCH REPORT

Information on patent family members

International application No <b>PCT/JP2009/060296</b>
--

Patent document cited in search report	Publication date	Patent family member(s)	Publication date
US 2006267779 A1	30-11-2006	US 2007144933 A1	28-06-2007
US 2007085015 A1	19-04-2007	NONE	
WO 2008054717 A	08-05-2008	US 2008130837 A1	05-06-2008
US 2006212986 A1	28-09-2006	NONE	
US 2003160196 A1	28-08-2003	JP 3785372 B2	14-06-2006
		JP 2003248278 A	05-09-2003