

June 27, 1933.

L. M. RABINOWITZ

1,915,580

FEEDING ATTACHMENT FOR SEWING MACHINES

Filed Aug. 9, 1928

2 Sheets-Sheet 1

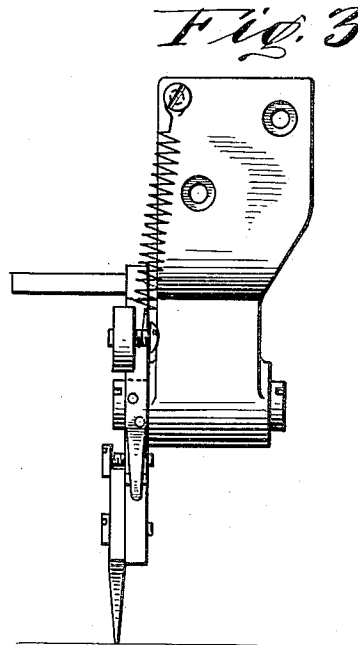
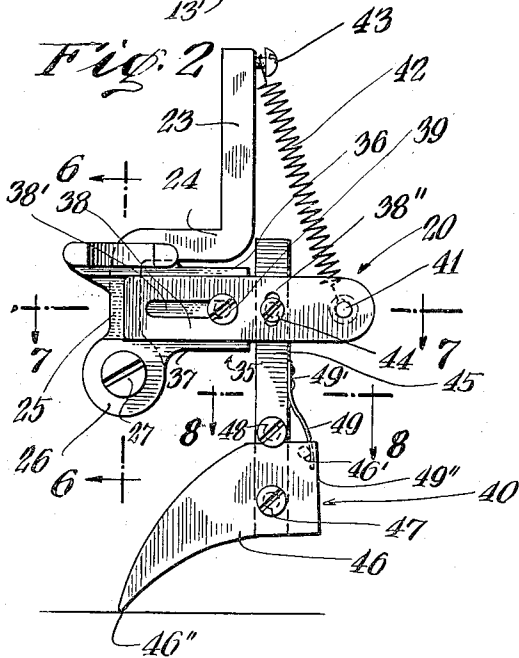
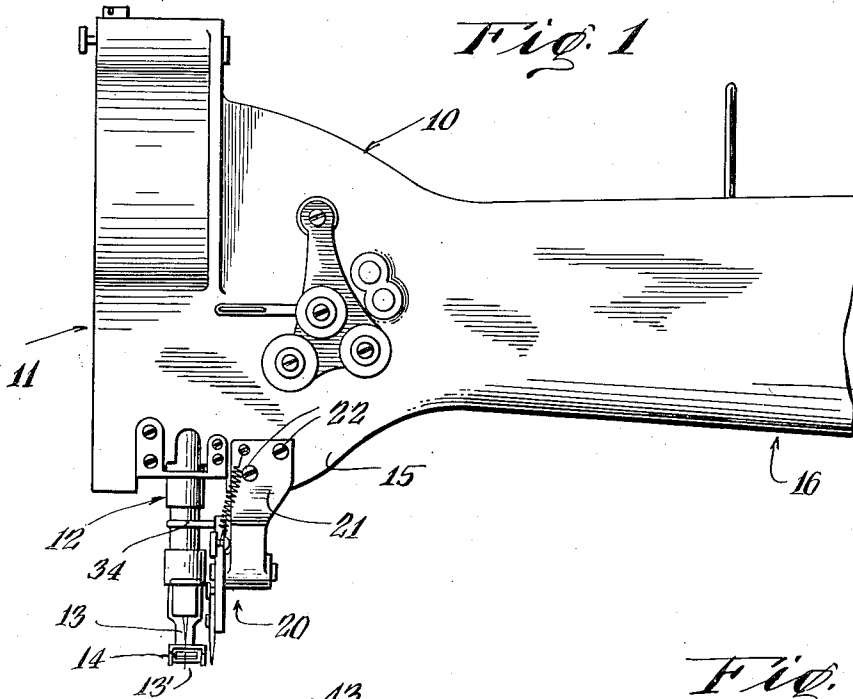

INVENTOR.  
*Louis M. Rabinowitz*

BY *his*

ATTORNEY  
*Edward M. Everts*

June 27, 1933.

L. M. RABINOWITZ

1,915,580

FEEDING ATTACHMENT FOR SEWING MACHINES

Filed Aug. 9, 1928

2 Sheets-Sheet 2

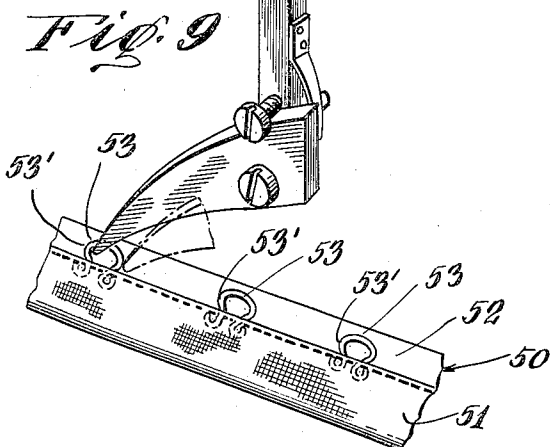
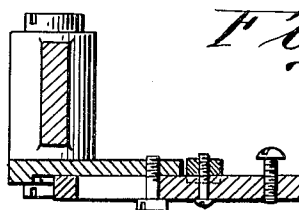
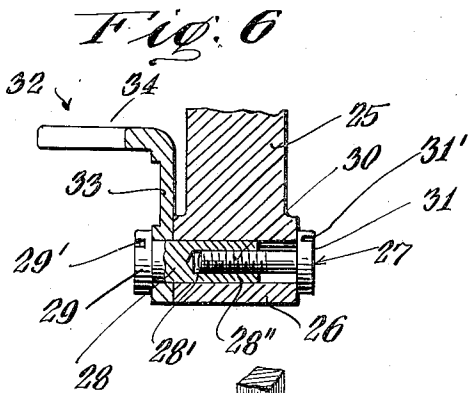
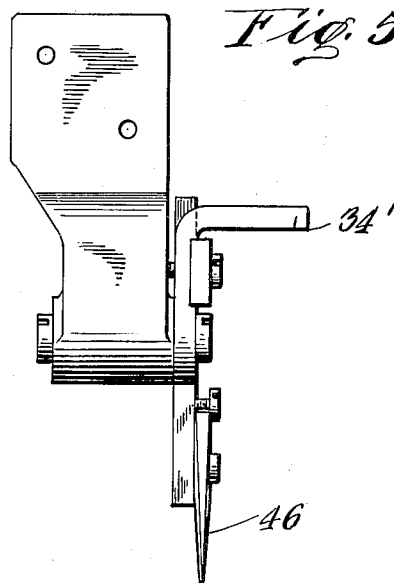
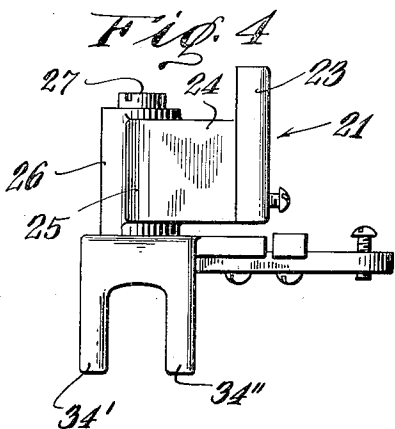

INVENTOR.  
*Louis M. Rabinowitz*  
BY *his*  
ATTORNEY  
*Edward M. Ervate*

# UNITED STATES PATENT OFFICE

LOUIS M. RABINOWITZ, OF BROOKLYN, NEW YORK

FEEDING ATTACHMENT FOR SEWING MACHINES

Application filed August 9, 1928. Serial No. 238,416.

My present invention relates to attachments for sewing machines and the like, particularly such as are adapted to prevent contact or engagement between the needle or needles on such a sewing machine or the like and the metal of the eyes or like fastening devices which are preferably carried by a supporting tape and are being sewed on to a garment or the like by means of a sewing machine to which the attachment of the present invention has been applied. It is an object of the present invention to devise attachments of the general character specified above which are simple in construction, which may be readily and conveniently fabricated and attached to the sewing machines or the like with which they are intended to be employed, which are arranged to be operated by such sewing machines or the like, and which in their operation enable garment manufacturers and the like to attach eye or like fastener tape to garments or the like without danger of the needle or needles of the sewing machines or the like being brought into contact with the metal of the eyes or other fasteners in such a way as to tend to break or damage the needle or needles or to injure the eyes or other fasteners. It is another object of the present invention to provide mechanisms of the general character specified which will enable garment manufacturers and the like to attach eye and similar fastener tapes to garments without gaps or loose ends, so that by means of the present invention a cleaner and better looking job of the sewing operation may be done in a way to add strength to the tapes and to the garments, fasten the eyes or other fastening elements more safely and more securely in place and to yield a cleaner and better looking garment.

In the accompanying specification I shall describe, and in the annexed drawings show, an illustrative embodiment of the present invention. It is, however, to be clearly understood that my invention is not limited to the specific embodiment thereof herein shown and described for purposes of illustration only.

Referring to the drawings, wherein I have

shown the aforesaid illustrative embodiment of the present invention:

Fig. 1 is a fragmentary side elevation of the arm and associated mechanism of a sewing machine having applied thereto one of the attachments of the present invention comprising the aforesaid illustrative embodiment of the same;

Fig. 2 is a side elevation, on an enlarged scale, of the aforesaid illustrative embodiment of the present invention attached to the arm or other portion of the frame of the sewing machine shown in Fig. 1 of the drawings;

Fig. 3 is an edge view of the mechanism illustrated in Fig. 2 of the drawings;

Fig. 4 is a top plan view of the pivoted operating member constituting a part of the attachment comprising the aforesaid illustrative embodiment of the present invention;

Fig. 5 is a rear plan view of the attachment illustrated in Fig. 3 of the drawings;

Fig. 6 is a fragmentary cross-sectional view taken along line 6—6 of Fig. 2 of the drawings;

Fig. 7 is a fragmentary cross-sectional view taken along line 7—7 of Fig. 2 of the drawings;

Fig. 8 is a fragmentary cross-sectional view taken along line 8—8 of Fig. 2 of the drawings; and

Fig. 9 is a fragmentary view, in perspective, indicating the manner of operation of the attachment of the present invention.

Before describing the aforesaid illustrative embodiment of the present invention it may be desirable briefly to refer to the state of the prior art to the field of which the present invention belongs. Hitherto, when eye or like fastener tape was to be stitched on to a garment or like article, it was necessary either that the stitching operation avoid the eyes or like fastening devices altogether, as by being passed through a portion of the supporting tape remote from the eyes or like fastening devices, or, if the line of stitching, as was preferable, passed across the eyes or equivalent fastening devices, the operator had to take the chance that the needle or needles of the sewing machine by means of which the stitching operation was being con-

ducted would come into contact or engagement with the metal portions of the eyes or equivalent fastening devices and would either become broken or damaged, or would injure the eyes or other fastening devices and perhaps the tape itself. Accordingly, the sewing operation, where the line of stitching passed through the eyes or equivalent fastening members themselves, was generally very slowly conducted so that as the sewing needle or needles approached each of the eyes or equivalent fastening members, it could be manually adjusted to prevent contact or engagement between the eye or equivalent fastening member and the sewing needle or needles.

These disadvantages are overcome and certain important advantages rendered possible by means of the devices of the present invention. Referring now to the aforesaid illustrative embodiment of the present invention, and with particular reference to the drawings illustrating the same, 10 indicates an arm or similar portion of the framework of a sewing machine or the like which houses or contains the needle operating mechanism and other portions of the mechanism of the sewing machine. Associated with the arm 10 is the head 11 which contains a portion of the mechanism for causing the vertical reciprocation and the backward and forward movement of the needle holder 12 holding the needle 13 and with which is associated the presser foot 14. The parts thus far referred to are of the usual or ordinary type of construction common in sewing machines of the types now employed and need not further be described here.

Associated with, as by being removably secured adjacent the portion 15 of the arm 10 or head 11 of the sewing machine, which is itself generally designated by reference character 16, is an attachment constructed in accordance with the principles of the present invention and generally designated by reference character 20. In order to properly support the attachment 20 I provide a suitable bracket 21 which may be secured to the portion 15 of the framework of the machine 16 as by the screws 22. The bracket or equivalent supporting member 21 comprises the upper arm or portion 23, the substantially horizontal portion 24 and the downwardly depending portion 25 having the journal bearing 26 at its lower end, in which is rotatably or oscillatably supported the journal 27 shortly to be described in considerable detail.

The journal 27 comprises the main member 28 having the head 29 slotted at 29' so that it may be tightened to adjust it to the bearing. The main member 28 is provided with a hole 28' which is threaded as at 28'' to receive the threaded shank 30 of the securing member 31 which is slotted at 31' so that it

may be operated by a screw driver or like tool for its adjustment. Positioned between the downwardly extending portion 25 of the supporting arm or bracket 21 and the journal bearing 26, and the slotted head 29 of the main member 28, is a forked member generally designated by reference character 32 and comprising the downwardly extending supporting portion 33 and the forked portion 34 comprising the two spaced arms 34' and 34'' more clearly shown in Figs. 1, 2, 3, 4, 5 and 6 of the drawings.

As more clearly shown in Fig. 1 of the drawings, the forked portion 34 straddles the needle holder 12. Accordingly, as the needle holder moves back and forth, it will cause the oscillation of the forked member 32 about the journal 27 by the engagement of the needle holder 12 between the arms 34' and 34'' of the forked member 32.

The forked member 32 has the extension 35 provided with the flange portions 36 and 37 between which is adjustably held the arm 38 for a purpose shortly to be described. The arm 38 is slotted, as indicated at 38', so as to permit of its being adjustably retained between the flanges 36 and 37 of the extension 35 by means of a set screw or similar securing device 39, all as more clearly shown in Fig. 2 of the drawings. It will thus be apparent that the arm 38 and the mechanism carried thereby will be oscillated with the forked member 32 as the latter is oscillated by the engagement of the reciprocating needle holder 12 between the arms 34' and 34'' of the forked portion 34 of the member 32.

The member 38 is also slotted, as at 38'' so as to provide adjustable means for securing to the member 38 the fastener manipulating tool or implement generally designated by reference character 40. At its other end the member 38 may be provided with a pin 41 to which is secured one end of a tension spring 42, the other end of which is secured to the shank of a screw or like member 43 carried by the arm 23 of the bracket member or like supporting means 21. So that the fastener manipulating tool 40 may be rigidly but adjustably secured to the arm 38, I provide a set screw or equivalent securing means 44 passing through the slot 38'' and being secured in the arm 45 which carries the manipulating member 46.

This latter is pivotally attached as by means of the screw 47 to the lower portion of the arm 45. The limits of the pivotal movement of the tool or implement 46 at the screw 47 carried by the arm 45 are determined by means of a set screw or equivalent means 48 more clearly shown in Fig. 2 of the drawings. 49 indicates a leaf spring or the like secured, as at 49', to the arm 45 and bearing at its free end 49'' against a pin 46' carried by the manipulating member 46.

This completes the description of the con-

struction of the aforesaid illustrative embodiment of the present invention. The manner of assembling the same and of attaching the same to the frame of the sewing machine or the like will, it is believed, be apparent from the foregoing description. Likewise the manner of using, and the mode of operation of, the attachment will be clear from the foregoing description but may be briefly summarized as follows:

Assuming now that the attachment is secured in place as illustrated in Fig. 1 of the drawings and that the machine is started in operation in the usual manner, and that an eye tape 50 is used made up of the folds 51 and 52 of fabric and carrying between said folds the eyes 53, and assuming further that it is desired to sew the eye tape on to the garment, which latter is not here being deemed necessary to be shown, the tape will be fed along towards the needle in the usual manner. The action of the tension spring 42 and the leaf spring 49 will be, normally, to keep the point 46'' of the tool or like manipulating member 46 in contact with the fabric making up the tape 50 in alignment with the loop portions 53' of the eyes 53. Due to the manner of securing the attachment 40 to the sewing machine and the relation of the forked operating member 32 to the reciprocating needle holder 12, when the needle moves forward the tool or implement 46 will move backwards and vice versa.

Accordingly, as the sewing needle 13 descends so as to bring its point 13' adjacent a metal portion of the loop 53' of one of the eyes 53 and the forward movement of the needle commences, the point 46'' of the tool or manipulating member 46 will move backwards. The relation of the point 13' of the needle to the point 46' of the tool or manipulating member 46 is such as to cause the tool 46, if brought into contact with a portion of the loop 53' of the eye 53, to move such loop portion a sufficient distance to be cleared by the needle.

In the movement of the needle backwards, the tool or manipulating member 46 will be restored to its initial position and the operation will be repeated after each stitch taken by the needle. It will, however, be clear that only a few of the stitches will be taken in proximity to the metal portion, such as the loop 53' of the eye 53. Assuming, for example, that the eyes 53 are made of wire about twenty thousandths of an inch in diameter, the tool or manipulating member 46 should have a range of movement of about twice that or forty thousandths of an inch. This can be arranged easily by the proper proportioning of the parts making up the attachments of the present invention, all as will readily be apparent to those skilled in the art to which the present invention relates.

This completes the description of the mode of operation of the aforesaid illustrative embodiment of the present invention. It will be noted that the attachment comprising the aforesaid illustrative embodiment of the present invention is simple in construction, may be readily and economically fabricated and assembled and is readily attachable to the sewing machines with which they are intended to be used. In operation it will be noted that the device operates in a simple and expeditious manner for the purposes already set forth. That is, by means of the attachments of the present invention, contact or engagement between the needle or needles of the sewing machine and the eyes is avoided with consequent avoidance of danger of breaking or injuring the needles or the fasteners carried by the tapes which are being stitched to garments or like articles. Due to the fact that the line of stitching which attaches the fastener tape to the garment or like article may pass right through the loops or other portions of the eyes or other fastener members, a much stronger and neater job is rendered possible, the eyes or equivalent fastener members are more securely attached to the supporting tape and the tape itself more neatly and securely attached to the garment. A cleaner, stronger and better looking garment is thus obtained.

Other superiorities and advantages of the devices of the present invention, particularly as exemplified in the aforesaid illustrative embodiment of the same, will readily occur to those skilled in the art to which the present invention relates.

What I claim as my invention is:

1. In a sewing machine for attaching a tape carrying fastener elements to a garment, an attachment associated with and operable by the reciprocable needle carrying mechanism of such sewing machine and comprising a pivotally oscillatable member carrying a finger, pointed to engage successive fastener elements to move the same out of alignment with the needle of the sewing machine for preventing contact between the needle of such sewing machine and such successive fastener elements.
2. In a sewing machine for attaching a tape carrying fastener elements to a garment, an attachment associated with and operable by a horizontally reciprocable portion of such sewing machine and comprising a pivotally oscillatable spring-pressed member carrying a pointed finger and which yieldingly engages successive fastener elements to move the same out of alignment with the needle of the sewing machine for preventing contact between the needle of such sewing machine and such successive fastener elements.
3. In a sewing machine for attaching a tape carrying fastener elements to a garment,

an attachment associated with and operable by a movable portion of such sewing machine and comprising a pivotally oscillatable spring-pressed member carrying a pointed finger and which yieldingly engages successive fastener elements to move the same out of alignment with the needle of the sewing machine for preventing contact between the needle of such sewing machine and such successive fastener elements.

4. In a sewing machine for attaching a tape carrying fastener elements to a garment, an attachment associated with and operable by a reciprocable portion of such sewing machine and comprising a pivotally oscillatable spring-pressed member carrying a pointed finger and which yieldingly engages successive fastener elements to move the same out of alignment with the needle of the sewing machine for preventing contact between the needle of such sewing machine and such successive fastener elements.

5. In a sewing machine for attaching tape carrying a plurality of metal fastener elements to a garment or the like, an attachment comprising a forked member oscillatably associated with the reciprocable needle carrying mechanism of the sewing machine, in combination with a fastener-element manipulating tool carrying a pointed finger operated by said forked member to move successive metal fastener elements out of alignment with the needle of such sewing machine to prevent engagement between said needle and such metal fastener elements.

6. In a sewing machine for attaching tape carrying a plurality of metal fastener elements to a garment or the like, an attachment comprising a forked member oscillatably attached to a portion of the framework of the sewing machine, in combination with a pivotally oscillatable fastener-element manipulating tool carrying a pointed finger operated by said forked member to move successive metal fastener elements out of alignment with the needle of such sewing machine to prevent engagement between said needle and such metal fastener elements.

7. In a sewing machine for attaching tape carrying a plurality of metal fastener elements to a garment or the like, an attachment comprising a forked member oscillatably associated with the reciprocable needle carrying mechanism of the sewing machine, in combination with a spring-pressed fastener-element manipulating tool carrying a pointed finger operated by said forked member to move successive metal-fastener elements out of alignment with the needle of such sewing machine to prevent engagement between said needle and such metal fastener elements.

8. In a sewing machine for attaching tape carrying a plurality of metal fastener elements to a garment or the like, an attach-

ment comprising a forked member oscillatably attached to a portion of the framework of the sewing machine in combination with a pivotally oscillatable spring-pressed fastener-element manipulating tool carrying a pointed finger operated by said forked member to move successive metal fastener elements out of alignment with the needle of such sewing machine to prevent engagement between said needle and such metal fastener elements.

9. An attachment for sewing machines adapted to sew tape carrying a plurality of metal fasteners onto a garment, comprising a supporting member, a forked member movably carried by such supporting member, said forked member being in engagement with and moved by the reciprocable needle carrying mechanism of said sewing machine and a fastener-element manipulating tool carrying a pointed finger operated by said forked member to move successive metal fastener elements out of alignment with the needle of such sewing machine to prevent engagement between said needle and the metal of the metal fastener elements.

10. An attachment for sewing machines adapted to sew tape carrying a plurality of metal fasteners onto a garment, comprising a supporting member, a forked member oscillatably carried by such supporting member, said forked member being in engagement with and oscillated by a movable portion of the mechanism of said sewing machine and a fastener-element manipulating tool carrying a pointed finger operated by said forked member to move successive metal fastener elements out of alignment with the needle of such sewing machine to prevent engagement between said needle and the metal of the metal fastener elements.

11. An attachment for sewing machines adapted to sew tape carrying a plurality of metal fasteners onto a garment, comprising a supporting member, a forked member movably carried by such supporting member, said forked member being in engagement with and moved by a movable portion of the mechanism of said sewing machine and a fastener-element manipulating tool in the form of a spring-pressed oscillable fastener-element engaging member in adjustable engagement with and operated by said forked member to move successive metal fastener elements out of alignment with the needle of such sewing machine to prevent engagement between said needle and the metal of the metal fastener elements.

12. An attachment for sewing machines adapted to sew tape carrying a plurality of metal fasteners onto a garment, comprising a supporting member, a forked member oscillatably carried by such supporting member, said forked member being in engagement with and oscillated by a movable portion of the mechanism of said sewing machine and

a fastener-element manipulating tool in the form of a spring-pressed oscillatable fastener-element engaging member in adjustable engagement with and operated by said forked member to move successive metal fastener elements out of alignment with the needle of such sewing machine to prevent engagement between said needle and the metal of the metal fastener elements.

10 13. An attachment for sewing machines adapted to sew tape carrying a plurality of metal fasteners onto a garment, comprising a supporting member, a forked member oscillatably carried by such supporting member, said forked member being in engagement with and oscillated by a reciprocable portion of the mechanism of said sewing machine and a fastener-element manipulating tool in the form of a spring-pressed oscillatable fastener-element engaging member in adjustable engagement with and operated by said forked member to move successive metal fastener elements out of alignment with the needle of such sewing machine to prevent engagement between said needle and the metal of the metal fastener elements.

14. A needle-protecting attachment for sewing machines, comprising a pivotally supported finger the rear end of which is located in proximity to the point at which the needle enters the work, means for yieldingly holding and guiding the rear end of said finger in predetermined relation to the work and to the said needle, and means for effecting reciprocating movements of the said finger, and means upon the rear end of said finger for engaging a wire or other obstruction and displacing it from the path of the descending movement of a needle.

15. A needle-protecting attachment for sewing machines, comprising a finger, means for pivotally supporting one end of the said finger, the opposite end of said finger being located in adjoining cooperative relation to the point of a needle, means for causing reciprocating movements of the said finger, the said movements being so related to the reciprocating movements of the needle as to position the adjoining end portion of the said finger in lateral alignment with the point of said needle at or about the time the same is entering the work, and means including a spring for yieldingly holding the point of said finger which adjoins the said needle in predetermined position with respect to the top side of the table of the sewing machine,

and means upon the rear end of said finger for engaging a wire or other obstruction and displacing it from the path of the descending movement of a needle.

16. A needle-protecting attachment for sewing machines, comprising an oscillatably supported member, a bar adjustably connected to said member, a finger pivotally connected to one end of said bar, a spring mounted upon said bar and having its free end in contact with the said finger and yieldingly pressing the latter in a direction toward the sewing machine table, the said finger having at its free end a portion which is adapted to contact with and to move a wire or other obstruction from a position in the path of descending movement of a needle, and means for effecting movements of the said finger in proper relation to the movements of the said needle to position the free end thereof in adjoining relation laterally of the said needle at or about the time the point thereof is entering the work.

17. A needle-protecting attachment for sewing machines, comprising an oscillatably supported member, a finger having yielding connection with the said member, said finger extending from the front toward the rear of the sewing machine and having at its rear end a portion which is adapted to contact with and to move a wire or other obstruction from a position in the path of the descending movement of a needle, and means for effecting movements of the said finger in proper relation to the movements of the said needle to position the rear end thereof in adjoining relation laterally of the said needle at or about the time the point thereof is entering the work.

18. A needle-protecting attachment for sewing machines, comprising a pivoted finger yieldingly held adjacent to and in predetermined relation with the point at which the needle of the sewing machine enters the work, and means operated by the drive of the sewing machine to reciprocate said finger in a plane substantially parallel to the line of travel of the work, one end of said finger being pointed, so that, upon the operation of the latter, it engages and removes an obstruction from the path of the needle.

In testimony, whereof, I have signed my name to this specification this 26th day of July, 1928.

LOUIS M. RABINOWITZ.

5  
10  
15  
20  
25  
30  
35  
40  
45  
50  
55  
60  
65

70  
75  
80  
85  
90  
95  
100  
105  
110  
115  
120  
125  
130