

[72] Inventor **Dewey P. Ankeney**
China Lake, Calif.
 [21] Appl. No. **826,944**
 [22] Filed **May 22, 1969**
 [45] Patented **Jan. 19, 1971**
 [73] Assignee **the United States of America as represented**
by the Secretary of the Navy

3,416,551	12/1968	Kinner.....	137/81.5
3,417,813	12/1968	Perry.....	131/81.5X
3,435,837	4/1969	Sher.....	137/8.15
3,437,100	4/1969	Rona.....	137/81.5
3,463,389	8/1969	Mott.....	131/8.15X
3,493,004	2/1970	Hellbaum.....	137/81.5
3,509,775	5/1970	Evans.....	137/81.5X

Primary Examiner—Samuel Scott
Attorneys—Edgar J. Brower and Roy Miller

[54] **ELECTRO-FLUERIC VALVE**
5 Claims, 2 Drawing Figs.

[52] U.S. Cl. **137/81.5,**
 235/201

[51] Int. Cl. **F15c 3/00**

[50] Field of Search..... 137/81.5; -
 235/201m.c., sens., p.f.

[56] **References Cited**
UNITED STATES PATENTS

3,187,762	6/1965	Norwood.....	137/81.5
3,238,959	3/1966	Bowles.....	137/81.5
3,366,131	1/1968	Swartz.....	137/8.15

ABSTRACT: A flueric device for channeling fluids into one of three outlet passageways in response to an electrical command. A chamber having three outlet channels is bisected by a metal leaf which is responsive to an electromagnetic command. Two fluid inputs at right angles to each other supply fluid input to the chamber. When no current is applied to the electromagnetic control of the metal leaf, fluid exits only from the center channel. If the electromagnetic control causes the leaf to bend toward one side of the chamber or the other, fluid will exit via one of the side channels or the other.

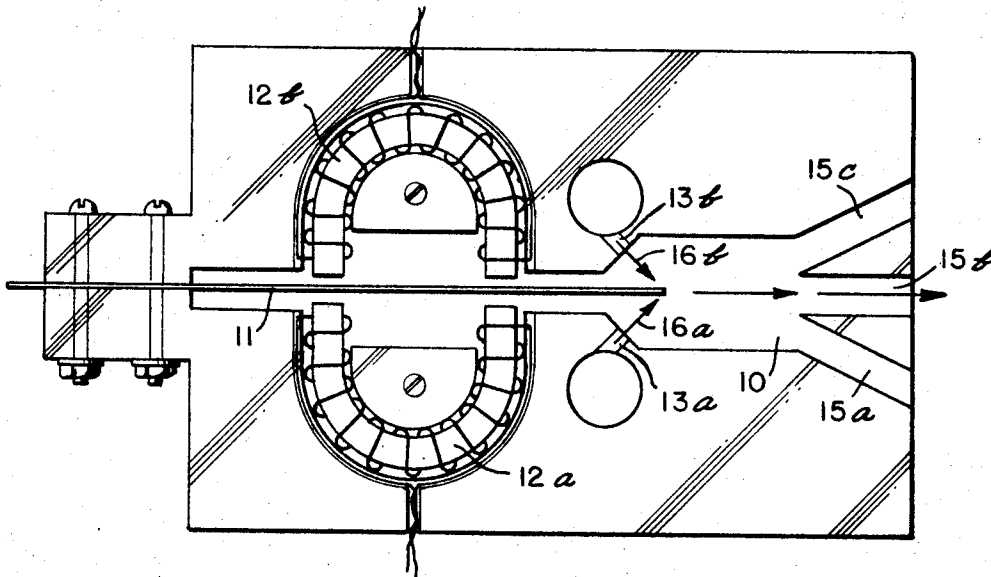

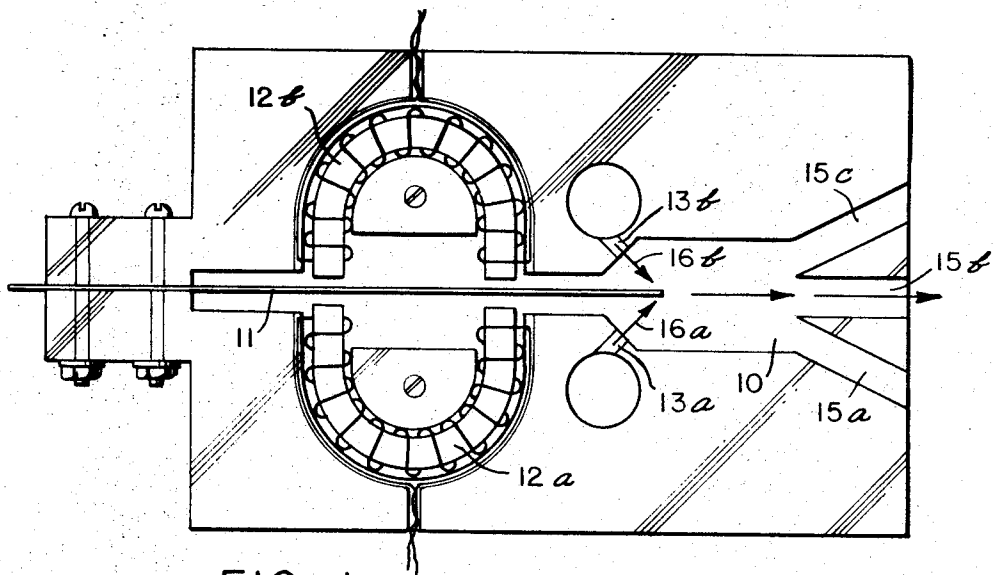

FIG. 1.

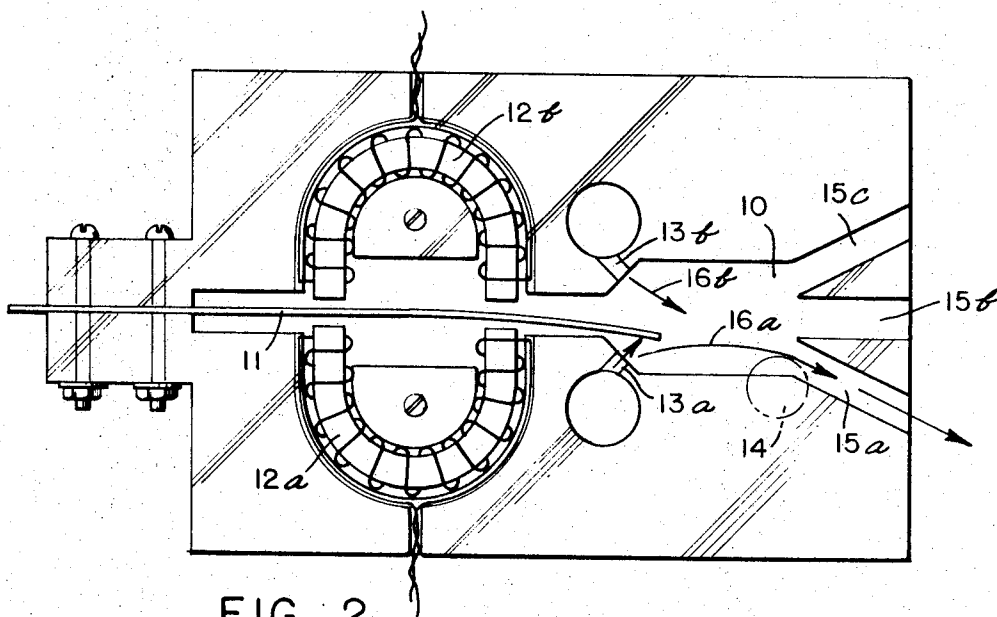

FIG. 2.

INVENTOR.
DEWEY P. ANKENY
BY
ROY MILLER
ATTORNEY.

ELECTRO-FLUERIC VALVE

GOVERNMENT INTEREST

The invention described herein may be manufactured and used by or for the Government of the United States of America for governmental purposes without the payment of any royalties thereon or therefor.

BACKGROUND OF THE INVENTION

It is desirable that the power stream of a fluid amplifier respond to electrical signals. In prior devices, the power stream has been controlled by operating solenoidal electrical valves in the channels leading to various control nozzles.

This method required the use of relatively complex and expensive valves which generally were located outside the fluid amplifier because of size. These control valves offset, to some extent, the inherent and advantageous small size of fluid amplifiers. Electrically operated valves also necessitated moving parts which reduced system reliability. Prior art devices often failed when contaminated, and used large amounts of power.

SUMMARY OF THE INVENTION

In accordance with the present invention a leaf spring constructed of a magnetic material is disposed to bisect two orthogonal fluid power streams. When the system is at rest the leaf is centered by its spring action as well as by the equal hydrodynamic forces created by equal diversion of the two impinging streams. When the system is energized by either of two electromagnets, the leaf is deflected until one of the impinging streams no longer intersects the leaf.

The unbalanced force, created by the deflected spring and the stream which no longer bisects the leaf, counterbalances the force created by the attracting magnet so that the system reaches one of its states of stable switched position. The impinging fluid streams are now directed down one of the side channels.

If the other electromagnet is energized and the leaf switched to the opposite side stable switched position, the fluid streams will exit via the opposite side channel. When no current is applied to the leaf, fluid always exits via the center channel.

BRIEF DESCRIPTION OF THE DRAWING

FIG. 1 is a plan view of the electroflueric valve; and FIG. 2 is a plan view of the electroflueric valve of FIG. 1 in which the leaf is deflected to one side to cause fluid to exit via a side channel.

DESCRIPTION OF THE PREFERRED EMBODIMENT

FIG. 1 shows an electroflueric valve. Chamber 10 is provided to house flexible member 11. Leaf 11 is capable of movement in response to electromagnets 12a and 12b. When electromagnet 12a is energized, leaf 11 will move adjacent to it. Similarly, leaf 11 will move adjacent to electromagnet 12b when it is energized.

Power nozzles 13a and 13b issue power streams 16a and 16b, respectively. Power stream 16a intersects power stream 16b orthogonally.

In the neutral position, when no power is applied to the electromagnets, leaf 11 is disposed so that it intercepts one half the diameter of power stream 16a and one half the diameter of power stream 16b. Thus, equal hydrodynamic pressure is placed on each side of leaf 11 and fluid exits via central outlet channel 15b.

Referring to FIG. 2, electromagnet 12a is energized and leaf

11 is deflected so that it intercepts the whole diameter of power stream 16a and none of the diameter of power stream 16b. The unbalanced force, created by deflected spring 11 and power stream 16a which intercepts leaf 11, counterbalances the force created by electromagnet 12a so that the system reaches one of its states of stable switched position. Fluid now exits via outlet channel 15a. Similarly, if electromagnet 12b were energized, leaf 11 would intercept all of power stream 16b and none of power stream 16a. Fluid would then exit via outlet channel 15c.

The valve is digital in that once fluid starts to flow the rate of flow will not increase no matter how far leaf 11 moves to one side or the other.

A partial vacuum 14 is created within chamber 10 as shown in FIG. 1. Thus as leaf 11 starts its travel to either side it is helped along by partial vacuum 14 thereby reducing the power needed to achieve switching.

I claim:

1. An electroflueric control device comprising:
 - a first power nozzle for issuing a first fluid power stream; a second power nozzle for issuing a second fluid power stream;
 - at least two outlet channels for receiving the first and second power streams;
 - a resilient member disposed between the first and second power nozzles, so that said member intercepts approximately one-half the diameter of the first and second power streams, and fluid exits via the first outlet channel; and
 - means adjacent to the resilient member for moving said member, so that when said member intercepts approximately the full diameter of the first power stream and does not intercept the second power stream, fluid exits via the second outlet channel.
2. An electroflueric control device as set forth in claim 1 wherein: the first fluid power stream intercepts the second fluid power stream orthogonally.
3. An electroflueric control device as set forth in claim 2 wherein:
 - the resilient member is magnetic; and
 - electromagnetic means are used for moving said member.
4. An electroflueric control device as set forth in claim 3 wherein: power stream flow is stable in the second outlet channel by virtue of a fixed wall disposed between the intersection of the fluid streams and the second outlet channel to create a reduced pressure region adjacent to the intersection of the fluid streams.
5. An electroflueric control device as set forth in claim 4 wherein:
 - there are three outlet channels for receiving the first and second power streams;
 - the resilient member is disposed between the first and second power nozzles, so that when said member intercepts approximately one-half the diameter of the first and second power streams, fluid exits via the center (first) outlet channel; and
 - the member is capable of movement; so that when said member intercepts approximately the full diameter of the first power stream and does not intercept the second power stream, fluid exits via one of the side (second) outlet channels; and
 - when said member intercepts approximately the full diameter of the second power stream and does not intercept the first power stream, fluid exits via the other side outlet channel.