



Europäisches Patentamt
European Patent Office
Office européen des brevets



(11) **EP 0 890 799 A2**

(12) **EUROPEAN PATENT APPLICATION**

(43) Date of publication:
13.01.1999 Bulletin 1999/02

(51) Int. Cl.⁶: **F24D 19/02**

(21) Application number: **98202231.1**

(22) Date of filing: **02.07.1998**

(84) Designated Contracting States:
**AT BE CH CY DE DK ES FI FR GB GR IE IT LI LU
MC NL PT SE**
Designated Extension States:
AL LT LV MK RO SI

(72) Inventor: **Verrijkt, Julien**
2100 Deurne (BE)

(74) Representative:
Debrabandere, René
Bureau De Rycker nv
Arenbergstraat 13
2000 Antwerpen (BE)

(30) Priority: **08.07.1997 BE 9700584**

(71) Applicant: **Verrijkt, Julien**
2100 Deurne (BE)

(54) **Radiator suspension**

(57) Radiator suspension for suspending a radiator of a central heating system to an upright wall, characterised in that it comprises a metal panel (1), means (2) for attaching this panel (1) to a wall (3) and means (4) provided on this panel (1) for suspending a radiator (5) to it.

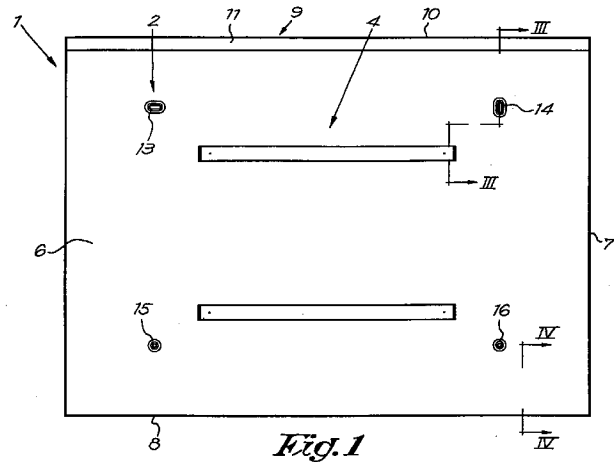

Fig. 1

EP 0 890 799 A2

Description

The present invention relates to a radiator suspension for suspending a radiator of a central heating system to an upright wall.

Radiators of central heating systems are normally suspended to hooks which are worked into the wall.

The radiators are suspended to these hooks and their inlet is connected by means of a tap to the warm water conduit of the central heating system, and also their outlet is connected to a water conduit of the central heating system.

If the radiators are suspended before the plastering is applied to the wall, it is impossible to plaster behind these radiators without uncoupling these radiators and removing them temporarily, which is of course time consuming.

Also if the radiators have been suspended after the plastering, it is very difficult to paint or put up wall paper behind the radiators without the cumbersome task of removing them, which requires shutting down the central heating system and draining the water.

As a result, once the radiators are put in place, people rarely paint or put up wall paper behind these radiators, and after some time the wall behind these radiators gets dirty. Parts of the wall which located behind the radiators and therefore dirty, are in some cases visible, though.

The invention aims at a suspension for a radiator whereby this disadvantage is remedied and whereby not only a safe suspension of the radiator is possible, but which also renders the wallpapering or painting behind the radiator redundant.

This aim is realised according to the invention by the fact that the suspension comprises a metal panel, means to attach this panel to a wall, and means provided on this panel to suspend a radiator to it.

The means for suspending the radiator to the panel can be the same as the means currently used for suspending a radiator directly to a wall, or can be especially adapted. They can differ depending on the model of the radiator.

The means for attaching the panel to the wall can consist of openings or preferably slits which allow that a screw or bolt is inserted through them and screwed in the wall.

Preferably the upper edge of the panel connects to a tablet.

The metal panel can, at least on its upright edges, be provided with forward or backward directed edges

In order to better show the characteristics of the invention, preferred embodiments of a radiator suspension are described hereafter, as examples without any limitative character whatsoever, reference being made to the accompanying drawings, in which:

figure 1 represents a front view of a radiator suspension according to the invention;

figure 2 represents a side view of the radiator suspension of figure 1;

figure 3 represents a cross-section along line III-III in figure 1, at an enlarged scale;

figure 4 represents a cross-section along line IV-IV in figure 1;

figure 5 represents a front view of a radiator suspension by means of a radiator suspension of the preceding figures;

figure 6 represents a cross-section along line VI-VI in figure 5, at an enlarged scale;

figure 7 represents a front view of an other embodiment of the radiator suspension according to the invention;

figure 8 represents a perspective view with partial cut-away of the radiator suspension of figure 1, attached to a wall and with a suspended radiator.

The radiator suspension represented in the figures mainly consists of a metal panel 1 which is provided with means 2 to attach it to an upright wall 3 and which is provided with means 4 for suspending a radiator 5 on it.

This panel 1 consists of a folded metal plate with a large rectangular almost flat portion 6 and raised edges 7 and 8 directed forward on the upright side edges and the bottom edge of the portion 6, respectively. The raised edges 7 and 8 give a nice finishing and an enhanced solidity. The raised edges 7 hide the means 2 and the means 4 from being viewed.

The upper edge of the portion 6 connects to a tablet 9 which is also a folded metal plate and preferably even forms one whole plate with the portion 6.

This tablet 9 also consists of a flat portion 10, an edge 11 folded downward at the foremost longitudinal edge and edges 12 folded downward at the side edges of the portion 10.

The portion 10 can possibly be provided with openings, for instance be perforated, to allow a flow of warm air to pass through.

An ornamental tablet, for instance in marble, can be placed on this tablet 9, as represented in dotted-and-dashed line in figure 3, possibly with the aid of supports so as to keep a space between the tablet 9 and the ornamental tablet open.

The means 2 for attaching the panel 1 to the wall 3 are mainly formed by openings, for instance four openings 13, 14, 15 and 16, through which screws 17 can be inserted and screwed in the wall 3 by means of plugs. These screws 3 are only represented in figure 3.

Around each opening 13, 14, 15 and 16 the portion 6 is pressed backwards so that, on the one hand, the head of the screws 17 is countersunk and, on the other hand, at the back side around the opening a protrusion is created which forms a distance holder so that the portion 6 is only in contact with the wall 3 with this protrusion and not with its entire back side when the panel 1 is attached to the wall 3, as can especially be seen in

figure 3.

The openings 13 and 14 are located at the same height and are both slits, whereby the opening 13 is a horizontal slit and the opening 14 is a vertical slit, so as to provide in a perfectly horizontal suspension of the panel 1.

The bottom openings 15 and 16 are round and located approximately below the openings 13 and 14.

The means 4 to suspend the radiator 5 differ depending on the type of radiator.

They can consist of hooks which are welded or riveted to the portion 6, but in the represented example, whereby the radiator 5 is provided at its back side with suspension braces 18, these means 4 consist of two braces 19 located on above the other, which are riveted or welded to the portion 6 with their middle parts and are directed forward with their legs, whereby these legs are provided with vertical slits 20 so that they form hooks for the suspension braces 18.

The panel 1 is lacquered in the same way as the radiator 5 and can be put on the market together with the radiator 5. The panel 1 can also be provided with a covering, for instance a synthetic film.

The suspension of a radiator 5 to the wall 3 is very simple. First the panel 1 is attached to the wall 3 by means of the screws 17. Subsequently the radiator 5 is suspended to the panel 1 by means of the means 4, for instance placed with its suspension braces 18 in the slits 20 of the braces 19, after which this radiator 5 can be connected to the water conduits of the central heating system.

The panel 1 can be put in place both before and after the plastering of the wall 3.

In the former case it is easy to plaster around the panel 1.

The panel 1 thereby provides in a nice and permanent finishing behind the radiator 5. There is no need for painting or wallpapering. Also a tablet which is already attached to the wall 3 is immediately available.

Moreover, it is possible to provide the back side of the panel 1 with a thermally insulating plate.

Also, it is possible that the raised edges 7 and 8 are much larger than represented, and form actual side walls which extend alongside the radiator 5. It is even possible to add to this a front wall or attach a radiator cabinet to the panel 1 which covers the radiator at the front and at the sides.

The radiator suspension can also, instead of forward directed raised edges 7 and 8, be provided with backward directed raised edges 21 and 22, on the upright side edges and the upper edge of the portion 6, respectively, as represented in figures 7 and 8. It is also possible that a backward directed edge connects to the bottom edge of the portion 6.

In the embodiments represented in these figures 7 and 8, the tablet 9 is also left out, while the means 4 for suspending the radiator 5 are L-shaped profiles 23 which are directed vertically with their longitudinal direc-

tion and attached with one leg to the part 1 by means of for instance bolts 24. The other, forward directed leg is provided with means which form one or two hooks 25.

Between said edges 21 and 22 a thermal insulation 26 can be applied.

Because of the edges 21 and 22, the portion 6 is located at a distance from the wall 3, so that the panel 1 can cover the rising parts of the conduits 27 which connect to the radiator 5.

In the embodiments represented in the figures 7 and 8 the conduits extend at the back side of the portion 6 through the insulation 26 and each end in a forward directed part which extends through a previously applied opening 28 in the panel 1 and which connects to a connection piece or tap 29.

If on the lower edge of the portion 6 is also provided with a backward directed raised edge, the latter must of course be provided with the necessary excision or excisions for the conduits 27.

The two conduits 27 can, as represented in figure 8, connect to the bottom of the radiator 5, whereby in this case the two taps 29 are located next to each other.

The panel 1 is first slid with its openings 28 over the forward directed parts of the conduits 27 and attached to the wall 3. Subsequently, the taps 29 are connected and the outlets of these taps 29 are temporarily connected to each other by means of a shunt conduit 30 which is later removed when the radiator 5 is suspended and the taps 29 are connected thereto.

As represented in figure 7, a removable support 31 can be screwed on the panel 1, resulting in that the taps 29 can easily be mounted at the correct place with respect to the panel 1. This support 31 is also removed after the shunt conduit 30 when the radiator 5 is suspended.

The radiator 5 need not necessarily be a plate radiator as represented in figures 5, 6 and 8. It can also be a cast iron radiator or a radiator formed by welded pipes.

On the suspension one or more pipes can be attached for hanging towels and such like up to dry.

The means 2 for attaching the panel 1 to a wall 3 need not necessarily comprise slits. They can for instance also comprise pins which are attached to the back side of the panel 1 and which can be anchored in openings in the wall 3, or comprise hooks or braces which are attached to the back side and which co-operate with braces or hooks which are attached to the wall 3.

The invention is in no way limited to the embodiments described above and represented in the figures, but such radiator suspension can be realised in different forms and dimensions without leaving the scope of the invention.

Claims

1. Radiator suspension for suspending a radiator of a

central heating system to an upright wall, characterised in that it comprises a metal panel (1), means (2) for attaching this panel (1) to a wall (3) and means (4) provided on this panel (1) for suspending a radiator (5) to it.

5

2. Radiator suspension according to claim 1, characterised in that the means (4) for suspending the radiator (5) to the panel (1) are similar to the currently used means for suspending a radiator directly to a wall (3). 10
3. Radiator suspension according to any one of the preceding claims, characterised in that the means (2) for attaching the panel (1) to the wall (3) comprise openings (13,14,15,16), for instance at least two adjacent openings (13 and 14) located at approximately the same height, which are oblong, preferably in the horizontal and vertical direction, respectively. 15
20
4. Radiator suspension according to any one of the preceding claims, characterised in that the panel (1) is provided at its back side with distance holders. 25
5. Radiator suspension according to claims 3 and 4, characterised in that the openings (13,14,15,16) are surrounded by pushthroughs in such a way that around the openings (13,14,15,16) at the front side of the panel (1) a hollow and at the back side a protrusion is formed, whereby the distance holders are formed by these protrusions. 30
6. Radiator suspension according to any one of the preceding claims, characterised in that the panel (1) comprises an almost flat portion (6) and at least on the upright side edges thereof upright forward directed raised edges (7). 35
40
7. Radiator suspension according to claim 6, characterised in that the panel (1) is provided also on the bottom edge of the flat portion (6) with a raised edge (8) directed forward. 45
8. Radiator suspension according to any one of the preceding claims, characterised in that a tablet (9) connects to the upper edge of the panel (1).
9. Radiator suspension according to any one of claims 1 to 5, characterised in that the panel (1) comprises an almost flat portion (6) and at least on the upright side edges thereof upright backward directed raised edges (21), whereby at this back side possibly an insulation (26) is provided. 50
55
10. Radiator suspension according to claim 9, characterised in that the portion (6) is provided with at

least one opening (28) for the conduits (27), which partly extend at the back side of this portion (6).

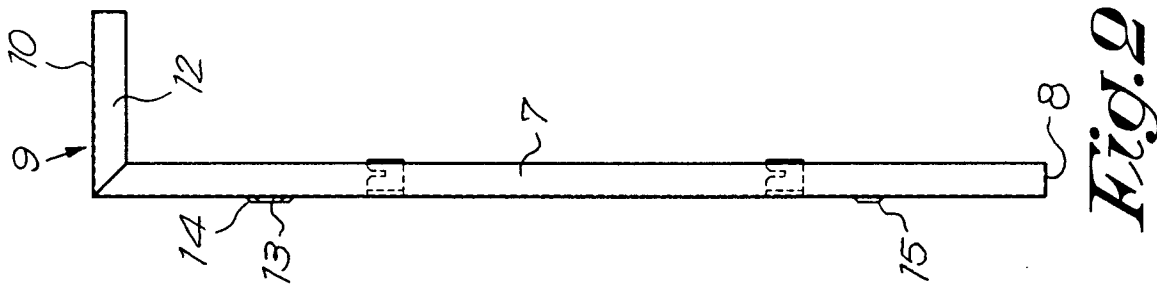

Fig. 2

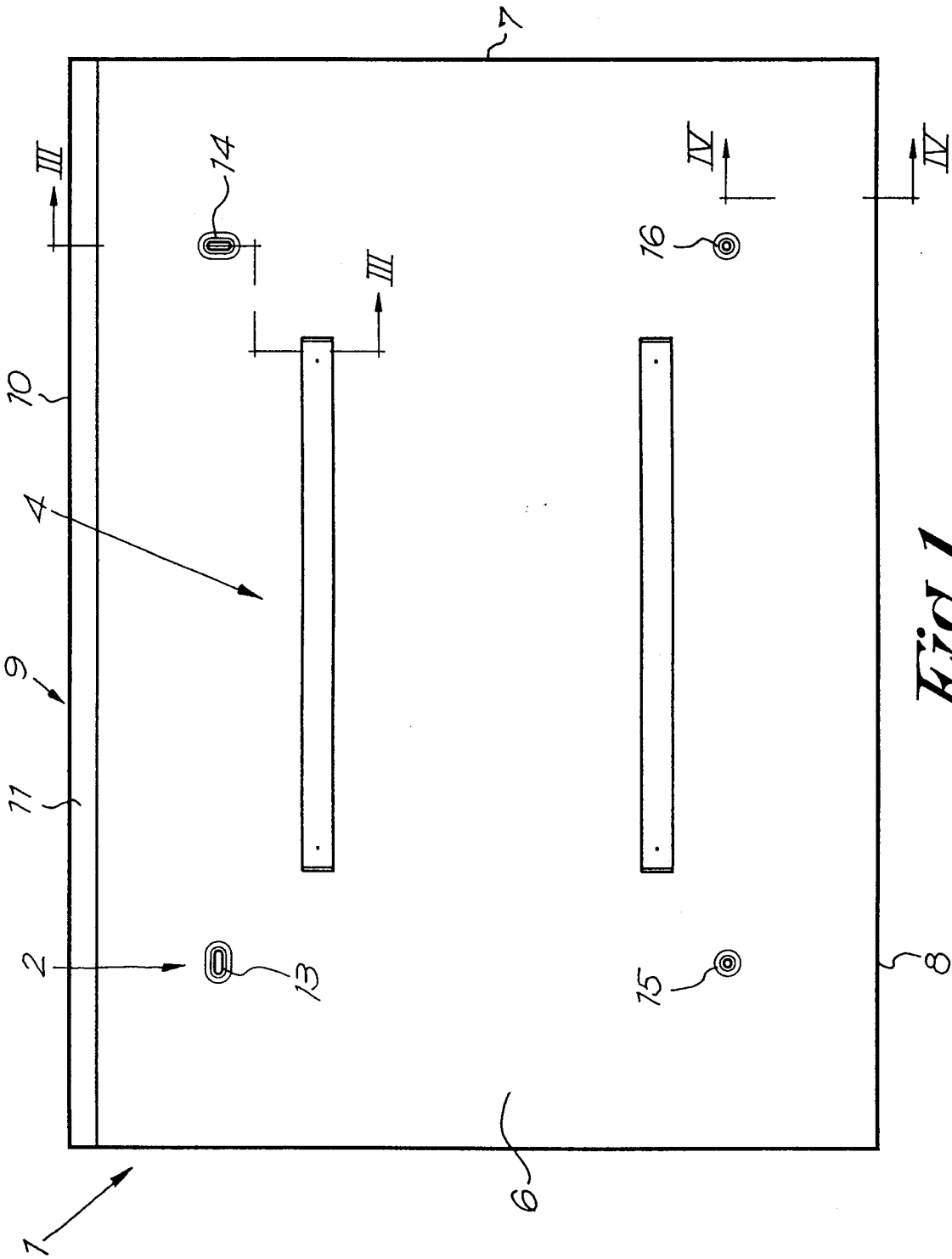
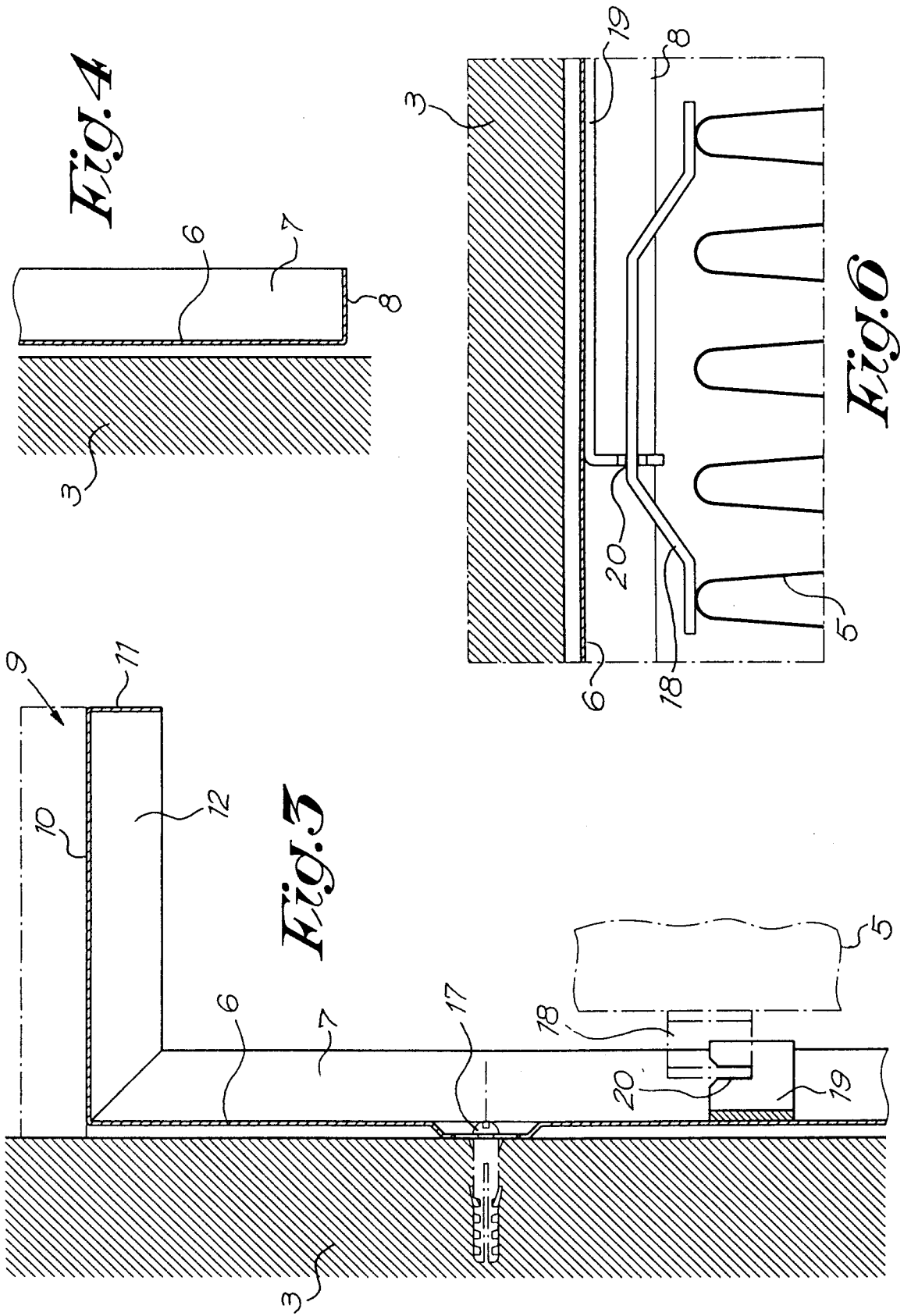

Fig. 1



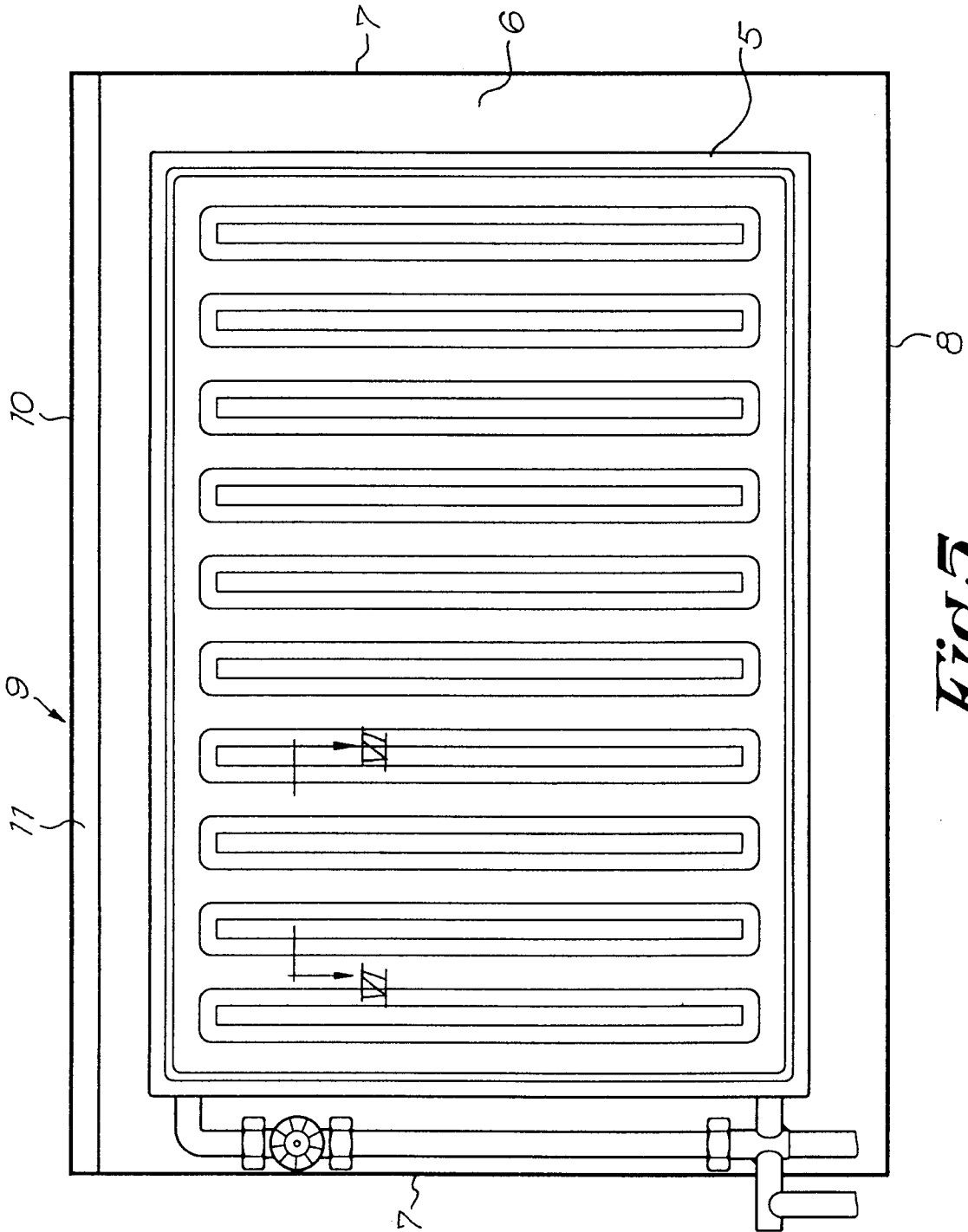

Fig. 5

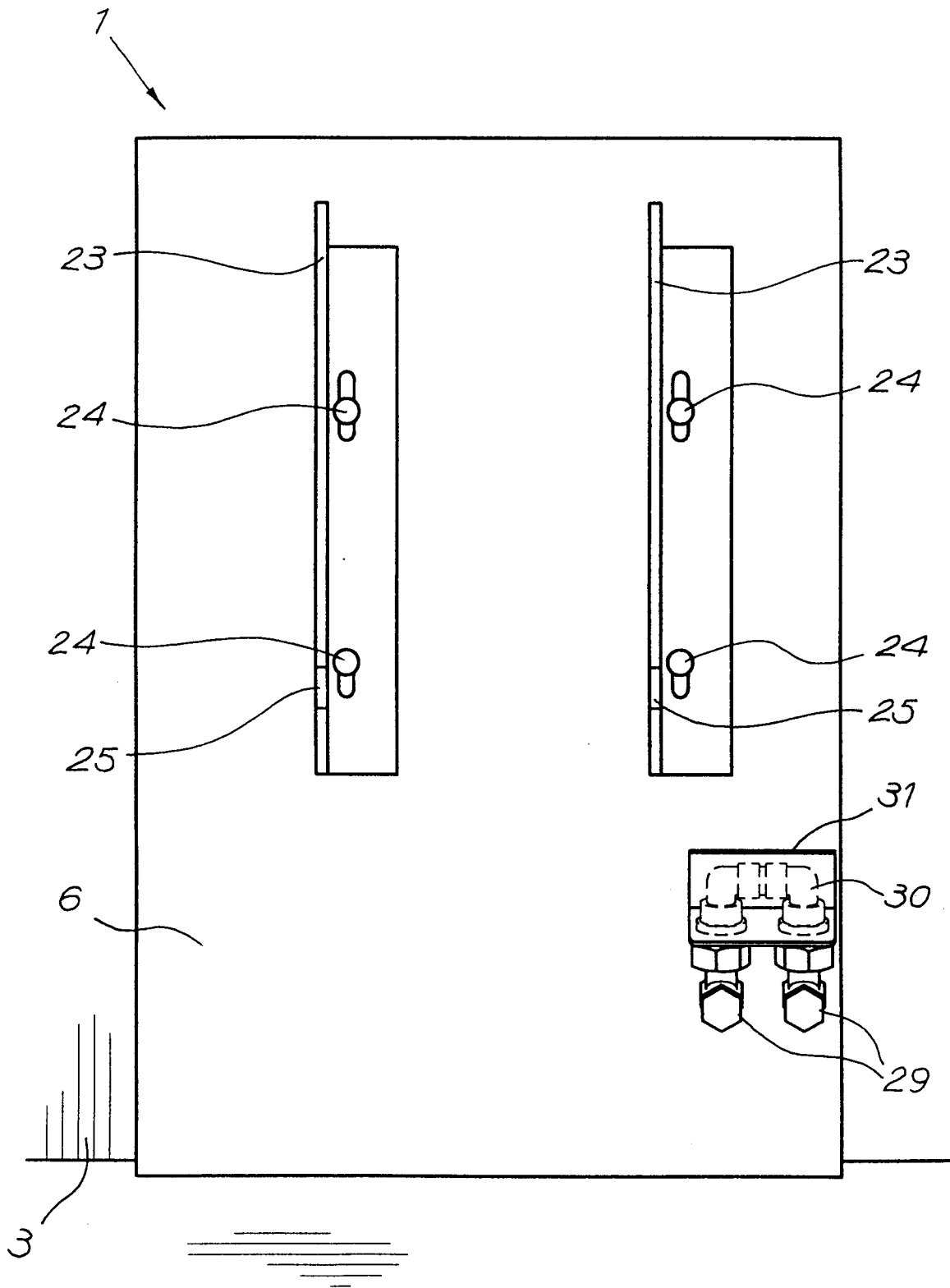

Fig. 7

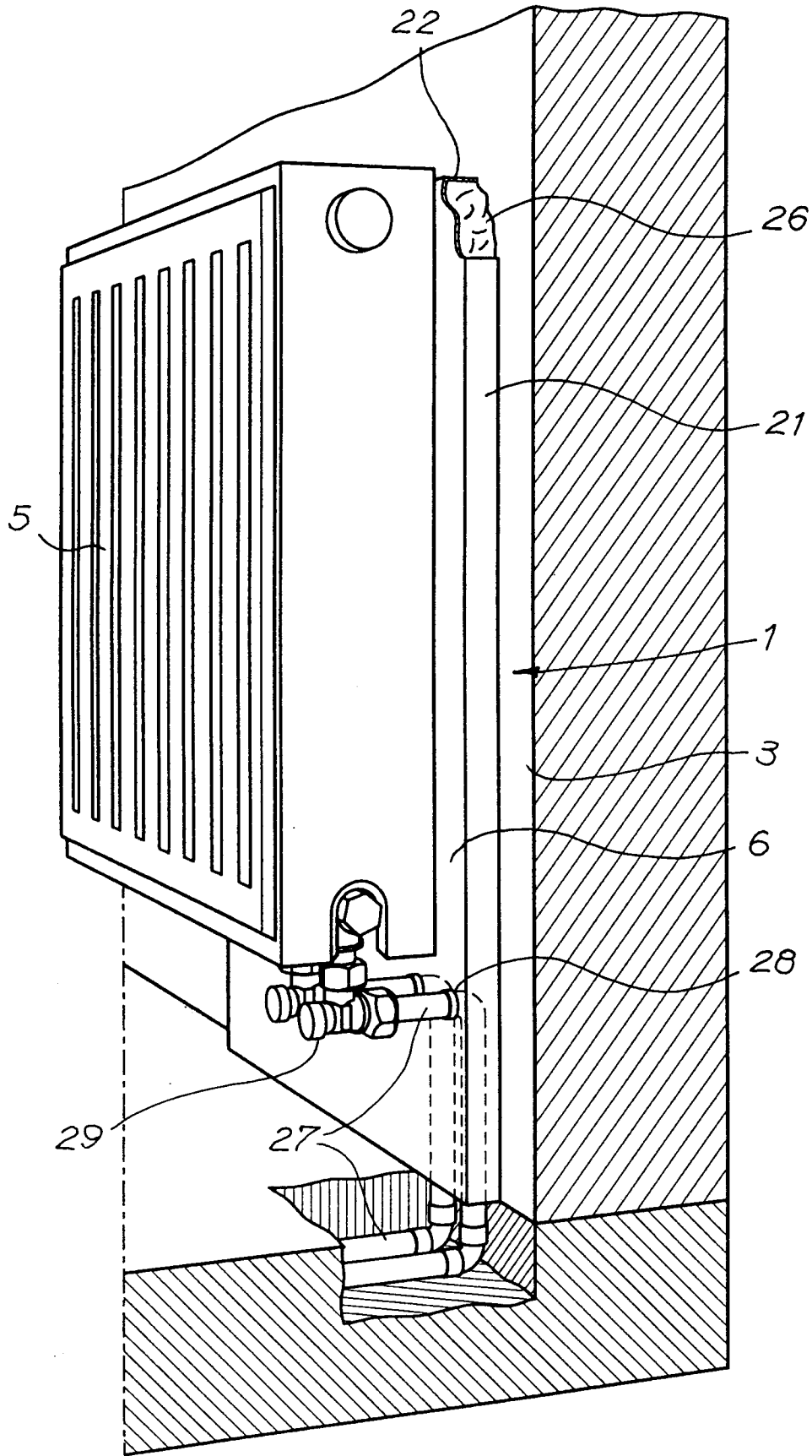

Fig. 8