

(19)



(11)

EP 2 398 973 B1

(12)

EUROPEAN PATENT SPECIFICATION

(45) Date of publication and mention of the grant of the patent:
20.08.2014 Bulletin 2014/34

(51) Int Cl.:
E04B 2/76 (2006.01)

(21) Application number: **10705438.9**

(86) International application number:
PCT/IE2010/000007

(22) Date of filing: **12.02.2010**

(87) International publication number:
WO 2010/092563 (19.08.2010 Gazette 2010/33)

(54) A FRAMING SYSTEM

RAHMENSYSTEM

SYSTÈME D'OSSATURE

(84) Designated Contracting States:
AT BE BG CH CY CZ DE DK EE ES FI FR GR HR HU IE IS IT LI LT LU LV MC MK MT NL NO PL PT RO SE SI SK SM TR

- **WOODLOCK, Henry**
Birmingham B20 2DW (GB)
- **BELK, Robert**
Birmingham, B73 6LP (GB)
- **JONES, Peter**
West Midlands, WV14 9NN (GB)

(30) Priority: **12.02.2009 IE 20090116**

(43) Date of publication of application:
28.12.2011 Bulletin 2011/52

(74) Representative: **Lane, Cathal Michael et al**
Tomkins & Co.
5 Dartmouth Road
Dublin 6 (IE)

(73) Proprietor: **Kingspan Holdings (IRL) Limited**
Kingscourt
County Cavan (IE)

(56) References cited:
US-A- 2 058 386 **US-A- 3 094 197**
US-A- 3 845 601 **US-A1- 2003 196 401**
US-A1- 2004 003 564 **US-A1- 2004 083 665**
US-B1- 6 276 103 **US-B1- 7 104 024**

(72) Inventors:
• **TIAN, Yishen**
West Midlands, WS4 1BB (GB)
• **WRIGHT, David**
Leicestershire, LE65 1DF (GB)

EP 2 398 973 B1

Note: Within nine months of the publication of the mention of the grant of the European patent in the European Patent Bulletin, any person may give notice to the European Patent Office of opposition to that patent, in accordance with the Implementing Regulations. Notice of opposition shall not be deemed to have been filed until the opposition fee has been paid. (Art. 99(1) European Patent Convention).

Description

Introduction

[0001] This invention relates to a framing system of the type comprising a plurality of studs and a header track for the studs, the studs and header track having adjustment means to accommodate movement of the header relative to the studs. A framing system comprises a number of roll formed metal elements jointed together. Such a framing system may be used to provide a wall such as a partition wall of a building such as a modular building. Many framing systems of this type are known. There is however a need for an improved system which will be easy to assembly whilst restricting tolerances and thereby ensuring greater accuracy in overall dimensions. Another issue associated with known systems of this type is that they are relatively expensive to manufacture and are of relatively complex construction. US-A-3 845 601 describes a metal wall framing system for building construction wherein channel shaped metal studs are firmly secured between top and bottom channel shaped metal tracks without the use of separate fasteners by an arrangement of lugs, tabs and punched slots that hold the studs tightly to the tracks in a predetermined position. US 2003-0196401 describes a stud for a framing system. There is a need to improve the fixation of the studs to further elements of the framing system. US2004-0083665 and US 200403336564 describe structural wall construction methods wherein the studs comprise slots in flanges of C-shaped studs.

[0002] The invention is directed towards providing improved stud and framing system which provides for flexible movement and allows for deflection of the host structure.

Statements of Invention

[0003] According to the invention, as described herein with reference to the claims, there is provided a stud for a framing system, the stud comprising a generally channel form, comprising a stud web and first and second side flanges extending from the web the flanges each having an inturned lip at the upper edge thereof to define a generally C-shaped form, the stud web having a pair of longitudinally extending elongate fixing slots with closed ends, the web slots being equi-spaced from a central longitudinal axis of the stud web each of the flanges having a single longitudinally extending elongate fixing slot therein adjacent to one end of the stud, the slots being located on the central longitudinal axis of the flanges.

A further embodiment of the present invention includes a framing system comprising a plurality of studs as described above and a header track for the studs, the header track having a web and a pair of side flanges which extend in use to embrace the stud web and the side flanges of the studs in a relatively tight fit.

[0004] In one embodiment the web comprises at least one longitudinally extending elongate fixing slot therein. The web slot is preferably closed at both ends thereof to confine the fixing.

5 **[0005]** In one case the web comprises two laterally spaced-apart elongate fixing slots therein. The web slots may be located on opposite sides of a central longitudinal axis of the web. Preferably the web slots are equi-spaced from the central longitudinal axis of the web.

10 The web slots may be aligned with the flange fixing slot. In a preferred embodiment the framing system comprises an ancillary element for fixing to the stud through the web fixing slot(s).

15 In one embodiment the ancillary element comprises a cleat. The cleat preferably comprises an angle form having a stud portion for fixing to the web of the stud and a header portion for mounting to a header.

20 The flange may comprise a single slot. In one case the single slot is located along a central longitudinal axis of the flange.

Preferably each of the first and second flanges comprise a fixing slot.

25 **[0006]** The side flanges may comprise an inturned lip at the upper edge thereof to define a generally C-shaped form.

30 **[0007]** In one case the header track comprises a channel having a web and a pair of depending flanges. At least one of the header flanges has an indicating means on the outermost face thereof.

The indicator means may comprise a line provided on or marked on the flange. The indicating means may be provided on both flanges of the header.

35 **[0008]** The invention also provides a building system comprising a framing system of the invention.

[0009] The invention further provides a stud for a framing system, the stud comprising a generally channel form comprising a web and first and second side flanges extending from the web wherein at least one of the flanges has a longitudinally extending elongate fixing slot therein adjacent to one end of the stud and the web having at least one fixing slot therein.

40 **[0010]** According to the invention there is provided a framing system comprising a plurality of studs and a header track for the studs, the studs and header track having adjustment means to accommodate movement of the header relative to the studs, characterised in that the adjustment means comprises a longitudinally extending slot in the stud and a fixing for fixing the header to the stud.

45 **[0011]** In one embodiment the stud comprises a generally channel form comprising a web and first and second side flanges extending from the web wherein at least one of the flanges has a longitudinally extending elongate fixing slot therein adjacent to one end of the stud.

[0012] Desirably the slot is closed at both ends thereof.

[0013] In one embodiment the flange comprises a single slot. In this case the single slot is preferably located

along a central longitudinal axis of the flange.

[0014] In one embodiment each of the first and second flanges comprise a fixing slot.

[0015] In one embodiment the side flanges of the stud comprise an inturned lip at the upper edge thereof to define a generally C-shaped form.

[0016] In one case the header track comprises a channel having a web and a pair of depending flanges.

[0017] In one embodiment of the invention at least one of the header flanges has an indicating means on the outermost face thereof. The indicator means may comprise a line provided on or marked on the flange. In one case the indicating means is provided on both flanges of the header.

[0018] The invention also provides a building system comprising a framing system of the invention.

[0019] In another aspect the invention provides a stud for a framing system, the stud comprising a generally channel form comprising a web and first and second side flanges extending from the web wherein at least one of the flanges has a longitudinally extending elongate fixing slot therein adjacent to one end of the stud.

[0020] Desirably the slot is closed at both ends thereof.

[0021] In a preferred embodiment the flange comprises a single slot. In this case the single slot is preferably located along a central longitudinal axis of the flange.

[0022] In one embodiment each of the first and second flanges comprise a fixing slot. The side flanges may comprise an inturned lip at the upper edge thereof to define a generally C-shaped form.

[0023] In a further aspect the invention provides a method of constructing a framing system comprising the steps of:-

providing at least two studs of the invention each with an elongate slot therein at the upper end thereof;

spacing the studs apart;

placing a header over the studs;

extending a fastener through the header and each elongate slot in the stud;

adjusting the header relative to the studs; and

tightening the fasteners to secure the header to the studs.

Brief Description of the Drawings

[0024] The invention will be more clearly understood from the following description thereof, given by way of example only in which:-

Fig. 1 is an elevational view of part of a framing system according to the invention;

Fig. 2 is an isometric view of a stud according to the invention;

Fig. 3 is a cross view of the stud;

Fig. 4 is an elevational view of the stud;

Fig. 5 is an isometric view of a header track;

Fig. 6 is a cross sectional view of a joint between a stud and track;

Fig. 7 is an elevational view of the joint between the stud and track;

Figs. 8 to 10 are cross sectional views of the framing system in different configurations of use;

Fig. 11 is an elevational view of part of a framing system according to another embodiment of the invention;

Fig. 12 is an isometric view of a header used in the framing system of Fig. 11;

Fig. 13 is an exploded view of part of another framing system of the invention;

Fig. 14 is an isometric view of the assembled framing system of Fig. 13;

Fig. 15 is an elevational view of the framing system;

Figs. 16 and 17 are views of fixings used in the framing system; and

Figs. 18 to 20 are end views illustrating the framing system in different positions, in use.

Detailed Description

[0025] Referring to the drawings there is illustrated a framing system comprising a number of frame elements typically of metal, in this case rolled steel sections.

[0026] The framing system comprises a plurality of laterally spaced-apart studs 1 or uprights. The studs 1 are interconnected by a header 2 which extends generally horizontally.

[0027] Each stud 1 comprises an elongated generally C-shaped lipped channel having a web 3 and side flanges 4, 5 which extend continuously the length of the element. The side flanges 4, 5 have inturned lips 7, 8 at the upper edge to define a generally C-shaped form. Each of the flanges 4, 5 has an elongate slot 6 therein which is typically punched out. The slot 6 is located on the central longitudinal axis of the flanges 4, 5.

[0028] The header 2 is of channel section comprising a web 10 and a pair of flanges 11, 12 which extend to

embrace the web 3 and flanges 4, 5 of the studs 1 as illustrated. The header 2 is sized such that the depending flanges 11, 12 embrace the studs 1 to which it is to be secured in a relatively tight fit.

[0029] The header 2 is mounted to the studs 1 in such a way as to accommodate limited vertical movement of the header 2 relative to the studs 1. Fixings 20 are screwed through the flanges 11, 12 of the header and extend to engage in the slots 6 in the stud flanges 4, 5.

[0030] The fixings 20 preferably have shallow heads in order to eliminate a bulging effect on boarding which is subsequently applied over the stud and track system. The overall shaft length will generally be a minimum length of 26mm with coarse thread. The minimum design capacity of the fixings is 2.28 kN.

[0031] To assemble a framing system of the invention a number of vertical studs 1 are arranged with their elongate slots 6 at the uppermost ends thereof. The studs 1 are spaced-apart in accordance with the specification required. A header 2 is then placed over the studs 1 and fasteners or fixings 20 are used to secure the header 2 to the studs 1. The fixings 20 are tightened to secure the joint whilst still permitting movement of the header 2 relative to the studs 1 in response to structure settlement during construction.

[0032] In the invention the header 2 can move vertically relative to the studs 1. In this way structural parts such as walls carried by the studs 1 are isolated from stresses that may be applied to the header 2, for example from a structure 25 above the header 2 to which the header is attached by fixings 26.

[0033] For flexibility in fixing it is preferred that the header flanges 11, 12 do not have fixing holes therein. In the preferred embodiment the fixings 20 may comprise self piercing rivets for connecting the header 2 to the studs 1 through the corresponding fixing regions.

[0034] Alternatively the header flanges 11, 12 may comprise fixing holes for reception of fixings. In one case such holes may comprise pilot holes in which case pop rivets may be used as fixings. In another case such holes may be sized for use with a staked fixing. In a further case the fixing hole may comprise a clearance hole for use with a self tapping screw.

[0035] Referring to Figs. 11 and 12 there is illustrated another framing system according to the invention which is similar to that described with reference to Figs. 1 to 10 and like parts are assigned the same reference numerals. In this case the flanges 11, 12 of the header track 2 have an indicator thereon, in this case in the form of a line 30 which extends along the length of the header 2. The marker line 30 indicates to the installer the location to which the fixings 20 should be inserted to guarantee the structure performance because of consistent fixing location.

[0036] The indicator line 30 may be provided on the header flanges 11, 12 in any suitable manner. For example, it can be applied using dedicated marking rollers or may be created using a suitable roll/marketing device or

printer. The line may be applied before or after roll forming of the track.

[0037] It will be appreciated that the framing system may be used in any suitable application. For example, the system may be used as a wall type frame to which cladding panels may be attached. Such as wall may be load bearing or non load bearing and may, for example, form part of a modular building point.

[0038] In the invention, there is no pre-punched hole or slot in the track 2. During the installation, the stud slot 6 is visible below the edge of the track for alignment. A fixing screw 20 is screwed into the track and passes the slot 6 of stud 1.

[0039] The screw 20 is fixed in the middle of the stud 1 which improves torsional stability.

[0040] In addition, because the slot 6 is on the centre line of stud 1, the fixing point is same for all the studs 1 regardless the stud spacing. Thus the loading capacity for the connection is consistent. Referring to Figs. 13 to 20 there is illustrated a framing system according to the invention in which parts similar to those of Figs. 1 to 12 are identified by the same reference numerals.

[0041] The framing system comprising a number of frame elements typically of metal, in this case rolled steel sections.

[0042] The framing system comprises a plurality of laterally spaced-apart studs 41 or uprights. The studs 41 are interconnected by a header 2 which extends generally horizontally.

[0043] Each stud 41 comprises an elongated generally C-shaped lipped channel having a web 3 and side flanges 4, 5 which extend continuously the length of the element. The side flanges 4, 5 have inturned lips 7, 8 at the upper edge to define a generally C-shaped form. Each of the flanges 4, 5 has an elongate slot 6 therein which is typically punched out. The slot 6 is located on the central longitudinal axis of the flanges 4, 5.

[0044] The header 2 is of channel section comprising a web 10 and a pair of flanges 11, 12 which extend to embrace the web 3 and flanges 4, 5 of the studs 41 as illustrated. The header 2 is sized such that the depending flanges 11, 12 embrace the studs 41 to which it is to be secured in a relatively tight fit.

[0045] The header 2 is mounted to the studs 41 in such a way as to accommodate limited vertical movement of the header 2 relative to the studs 1. Fixings 42 or 43 are screwed through the flanges 11, 12 of the header and extend to engage in the slots 6 in the stud flanges 4, 5.

[0046] The web 3 of a stud 41 has a pair of longitudinally extending elongate slots 40 with closed ends. The slots 40 are equi-spaced from a central longitudinal axis of the web 3. The slots 40 are typically punched out.

[0047] The system also comprises an ancillary element, such as a structural element, in this case an angle cleat 50 having a stud portion 51 and a track portion 52 which extend in use along the web 3 of the stud 41 and the web 10 of the header track 10 respectively. The stud portion 51 of the cleat 50 is attached to the web 3 of the

stud 41 by fixings 42 or 43 which extend through the slots 40. Fixing screws 45 may be used to fix the header portion 52 of the cleat through the header 2 to an upper support.

[0048] The fixings 42, 43 preferably have shallow heads in order to eliminate a bulging effect on boarding which is subsequently applied over the stud and track system. The overall shaft length will generally be a minimum length of 26mm with coarse thread. The minimum design capacity of the fixings is 2.28 kN.

[0049] The system of Figs. 13 to 20 is especially advantageous in that it allows the system to be readily reinforced at the joint between the studs and the header. The cleat 50 fixed to the web slots 40 increases the shear capacity of the connection. Thus the cleat 50 reinforces the joint for improved structural properties. The web slots 40 allow the cleat to be readily fitted and also facilitate any required movement between the cleat to which the header is attached and the stud 41.

[0050] In addition, in some situations an installer does not have ready access to both of the flange fixing slots 6. For example, a part (such as a structural beam) of the main structure may render access to one of the slots difficult or impossible. The cleat 50 can be fixed/anchored upwards into the head track web 10 and through to a structural substrate using suitable fixings 45. Fixings 42 or 43 may be inserted through the slots 40 in the web 3 of the stud 41 and into the stud portion 51 of the cleat 50.

[0051] In some cases the studs 41 can be directly fixed to the face of a slab/structural beam through the slots with no additional cleat or bracket.

[0052] Oversail studs would not require the slots in the oversail cleat which would reduce the cost of this component.

[0053] To assemble a framing system of the invention a number of vertical studs 41 are arranged with their elongate slots 6, 40 at the uppermost ends thereof. The studs 41 are spaced-apart in accordance with the specification required. A header 2 is then placed over the studs 41 and fasteners or fixings 42,43 are used to secure the header 2 to the studs 41. Cleats 50 may be used at some or all of the joints between the studs 41 and header 2. The fixings 42, 43 are tightened to secure the joint whilst still permitting movement of the header 2 relative to the studs 41, for example in response to structure settlement during construction.

[0054] In the invention the header 2 can move vertically relative to the studs 41. In this way structural parts such as walls carried by the studs 41 are isolated from stresses that may be applied to the header 2, for example from a structure 25 above the header 2 to which the header is attached by fixings 45.

[0055] For flexibility in fixing it is preferred that the header flanges 11, 12 do not have fixing holes therein. In the preferred embodiment the fixings 42,43 may comprise self piercing rivets for connecting the header 2 to the studs 1 through the corresponding fixing regions.

[0056] Alternatively the header flanges 11, 12 may comprise fixing holes for reception of fixings. In one case

such holes may comprise pilot holes in which case pop rivets may be used as fixings. In another case such holes may be sized for use with a staked fixing. In a further case the fixing hole may comprise a clearance hole for use with a self tapping screw.

[0057] Similar to the version illustrated in Figs. 11 and 12 the flanges 11, 12 of the header track 2 may have an indicator thereon, such as in the form of a line which extends along the length of the header 2. The marker line indicates to the installer the location to which the fixings 20 should be inserted to guarantee the structure performance because of consistent fixing location. The indicator line may be provided on the header flanges 11, 12 in any suitable manner. For example, it can be applied using dedicated marking rollers or may be created using a suitable roll/marketing device or printer. The line may be applied before or after roll forming of the track.

[0058] It will be appreciated that the framing system may be used in any suitable application. For example, the system may be used as a wall type frame to which cladding panels may be attached. Such as wall may be load bearing or non load bearing and may, for example, form part of a modular building point.

[0059] In the invention, there is no pre-punched hole or slot in the track 2. During the installation, the stud slot 6 is visible below the edge of the track for alignment. A fixing screw 42,43 is screwed into the track and passes the slots 6,40 of stud 41.

[0060] A fixing screw 42, 43 may be fixed in the middle of the stud 41 which improves torsional stability.

[0061] In addition, because the slot 6 is on the centre line of stud 1, the fixing point is same for all the studs 1 regardless the stud spacing. Thus the loading capacity for the connection is consistent. Because the slots 40 are equi-spaced from a central longitudinal axis of the web of the stud 41, the fixing points are same for all the studs 41 regardless the stud spacing. Thus the loading capacity for the connection is consistent.

[0062] The invention is not limited to the embodiments hereinbefore described which may be varied in detail, in accordance with the appended claims.

Claims

1. A stud (41) for a framing system, the stud comprising a generally channel form, comprising a stud web (3) and first and second side flanges (4, 5) extending from the web the flanges (4, 5) each having an in-turned lip (7, 8) at the upper edge thereof to define a generally C-shaped form, the stud web (3) having a pair of longitudinally extending elongate fixing slots (40) with closed ends, the web slots (40) being equi-spaced from a central longitudinal axis of the stud web(3), **characterised in that** each of the flanges (4, 5) has a single longitudinally extending elongate fixing slot (6) therein adjacent to

one end of the stud (41), the slots (6) being located on the central longitudinal axis of the flanges (4, 5).

2. A framing system comprising a plurality of studs (41) according to claim 1 and a header track (2) for the studs (41),
the header track (2) having a web (10) and a pair of side flanges (11, 12) which extend in use to embrace the stud web (3) and the side flanges (4, 5) of the studs (41) in a relatively tight fit. 5
3. A framing system as claimed in claim 2 wherein the web slots (40) are aligned with the flange fixing slot (6). 10
4. A framing system as claimed in claims 2 or 3 comprising an ancillary element (50) for fixing to the stud (41) through the web fixing slots (40). 15
5. A framing system as claimed in claim 4 wherein the ancillary element comprises a cleat (50). 20
6. A framing system as claimed in claim 5 wherein the cleat (50) comprises an angle form having a stud portion (51) which extends in use along the web (3) of the stud (41) for fixing to the web (3) of the stud (41) and a track portion (52) which extends in use along the web (10) of the header track (2) for mounting to a header. 25
7. A framing system as claimed in any of claims 2 to 6 wherein at least one of the header flanges (11, 12) has an indicating means (30) on the outermost face thereof. 30
8. A framing system as claimed in claim 7 wherein the indicating means comprises a line (30) provided on or marked on the flange (11, 12). 35
9. A framing system as claimed in claim 7 or 8 wherein the indicating means (30) is provided on both flanges (11, 12) or the header (2). 40
10. A building system comprising a framing system as claimed in any of claims 2 to 9. 45
11. A method of constructing a framing system according to any of claims 2 to 9 comprising;
spacing the plurality of studs apart;
placing the header track (2) over the studs;
extending fasteners through the header and each elongate slot in the plurality of studs;
adjusting the header relative to the studs; and
tightening the fasteners to secure the header to the plurality of studs. 50

Patentansprüche

1. Steg (41) für ein Rahmensystem, wobei der Steg im Allgemeinen eine Kanalform aufweist, welche eine Stegplatte (3) und erste und zweite Flansche (4, 5) aufweist, welche sich von der Platte erstrecken, wobei die Flansche (4, 5) jeweils eine nach innen gewandte Lippe (7, 8) an ihrer oberen Kante haben, um im Allgemeinen eine C-Form zu definieren, wobei die Stegplatte (3) ein paar von sich in Längsrichtung erstreckenden langgestreckten Befestigungsschlitzen (40) mit geschlossenen Enden hat, wobei die Plattenschlitze (40) gleichmäßig von einer mittigen Längsachse der Stegplatte (3) beabstandet sind, **dadurch gekennzeichnet, dass** jeder der Flansche (4, 5) einen einzigen sich in Längsrichtung erstreckenden langgestreckten Befestigungsschlitz (6) darin, benachbart zu einem Ende des Steges (41) hat, wobei die Schlitze (6) an der mittigen Längsachse der Flansche (4, 5) gelegen sind. 5
2. Rahmensystem, welches eine Vielzahl von Stegen (41) nach Anspruch 1 und eine Kopfschiene (2) für die Stege (41) aufweist,
wobei die Kopfschiene (2) eine Platte (10) und ein paar von Seitenflanschen (11, 12) hat, welche sich im Gebrauch derart erstrecken, dass sie die Stegplatte (3) und die Seitenflansche (4, 5) der Stege (41) in einer vergleichsweise festen Passung umgeben. 10
3. Rahmensystem nach Anspruch 2, wobei die Plattenschlitze (40) mit dem Flanschbefestigungsschlitz (6) ausgerichtet sind. 15
4. Rahmensystem nach Anspruch 2 oder 3, welches ein Hilfselement (50) zum Befestigen des Steges (41) durch die Plattenbefestigungsschlitze (40) aufweist. 20
5. Rahmensystem nach Anspruch 4, wobei das Hilfselement ein Winkelement (50) aufweist. 25
6. Rahmensystem nach Anspruch 5, wobei das Winkelement (50) eine Winkelform mit einem Stegteil (51) hat, welcher sich im Gebrauch entlang der Platte (3) des Steges (41) erstreckt, um die Platte (3) des Steges (41) und einen Schienenteil (52) zu fixieren, der sich im Gebrauch entlang der Platte (10) der Kopfschiene (2) erstreckt, um ein Kopfteil zu befestigen. 30
7. Rahmensystem nach einem der Ansprüche 2 bis 6, wobei zumindest einer der Kopfplansche (11, 12) ein Anzeigemittel (30) an seiner Außenseite hat. 35
8. Rahmensystem nach Anspruch 7, wobei die Anzeigemittel eine Line (30) aufweisen, die an dem 40

Flansch (11, 12) vorgesehen oder markiert ist.

9. Rahmensystem nach Anspruch 7 oder 8, wobei die Anzeigemittel (30) an beiden Flanschen (11, 12) oder an der Kopfschiene (2) vorgesehen sind. 5
10. Konstruktionssystem, welches ein Rahmensystem nach einem der Ansprüche 2 bis 9 aufweist.
11. Verfahren zum Aufbauen eines Rahmensystems nach einem der Ansprüche 2 bis 9, welches folgendes aufweist: 10

Beabstanden der Vielzahl von Stegen voneinander;
Anordnen der Kopfschiene (2) über den Stegen;
Führen von Befestigungselementen durch die Kopfschiene und jeden langgestreckten Schlitz in der Vielzahl von Stegen;
Einstellen der Kopfschiene relativ zu den Stegen; und
Festziehen der Befestigungselemente, um die Kopfschiene an der Vielzahl von Stegen zu sichern. 20

Revendications

1. Montant (41) pour un système d'ossature, le montant ayant une forme générale de canal, comprenant une âme de montant (3) et des premier et deuxième rebords latéraux (4, 5) s'étendant à partir de l'âme, chacun des rebords (4, 5) comportant une lèvre (7, 8) tournée vers l'intérieur au niveau de son bord supérieur pour définir une forme générale de C, l'âme de montant (3) comportant une paire de fentes de fixation allongées (40) s'étendant longitudinalement et munies d'extrémités fermées, les fentes (40) de l'âme étant espacées de façon égale par rapport à un axe longitudinal central de l'âme de montant (3), **caractérisé en ce que** 40
chacun des rebords (4, 5) comporte une seule fente de fixation allongée (6) s'étendant longitudinalement et adjacente à une extrémité du montant (41), les fentes (6) étant situées sur l'axe longitudinal central des rebords (4, 5). 45
2. Système d'ossature comprenant une pluralité de montants (41) selon la revendication 1 et un rail de tête (2) pour les montants (41), 50
le rail de tête (2) comportant une âme (10) et une paire de rebords latéraux (11, 12) qui s'étendent en utilisation pour épouser les âmes de montant (3) et les rebords latéraux (4, 5) des montants (41) dans un montage relativement serré. 55
3. Système d'ossature selon la revendication 2, dans lequel les fentes (40) de l'âme sont alignées avec

les fentes de fixation (6) des rebords.

4. Système d'ossature selon les revendications 2 ou 3, comprenant un élément auxiliaire (50) pour fixer le montant (41) à travers les fentes de fixation (40) de l'âme.
5. Système d'ossature selon la revendication 4, dans lequel l'élément auxiliaire comprend un taquet (50).
6. Système d'ossature selon la revendication 5, dans lequel le taquet (50) a une forme d'équerre comportant une portion de montant (51) qui s'étend en utilisation le long de l'âme (3) du montant (41) pour une fixation à l'âme (3) du montant (41) et une portion de rail (52) qui s'étend en utilisation le long de l'âme (10) du rail de tête (2) pour un montage sur un rail de tête.
7. Système d'ossature selon l'une quelconque des revendications 2 à 6, dans lequel au moins l'un des rebords (11, 12) du rail de tête comporte des moyens d'indication (30) sur sa face la plus à l'extérieur.
8. Système d'ossature selon la revendication 7, dans lequel les moyens d'indication comprennent une ligne (30) prévue sur ou marquée dans le rebord (11, 12).
9. Système d'ossature selon la revendication 7 ou 8, dans lequel les moyens d'indication (30) sont prévus sur les deux rebords (11, 12) du rail de tête (2).
10. Système de construction comprenant un système d'ossature selon l'une quelconque des revendications 2 à 9.
11. Procédé de construction d'un système d'ossature selon l'une quelconque des revendications 2 à 9 comprenant :
disposer de façon espacée la pluralité de montants ;
placer le rail de tête (2) par-dessus les montants ;
passer des fixations à travers le rail de tête et chaque fente allongée de la pluralité de montants ;
ajuster le rail de tête par rapport aux montants ;
et
serrer les fixations pour fixer le rail de tête à la pluralité de montants.

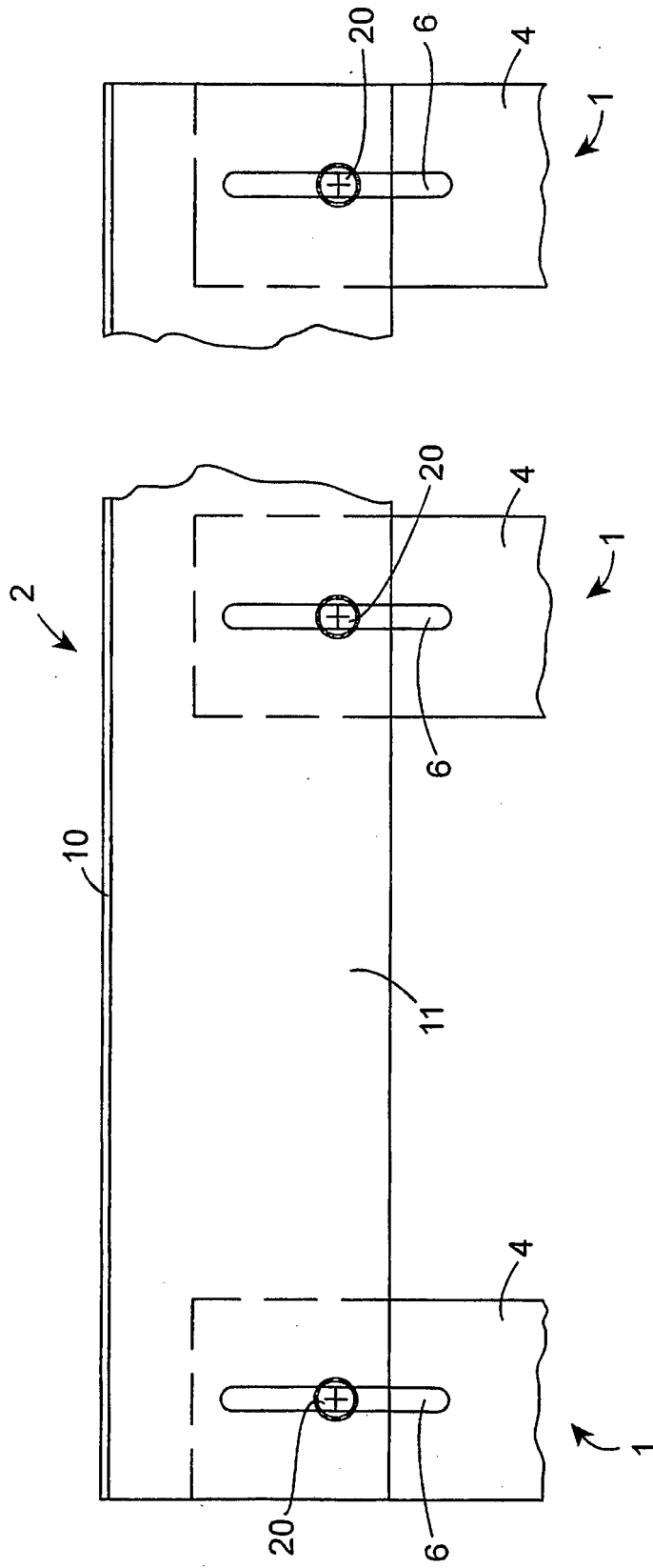

Fig. 1



Fig. 2

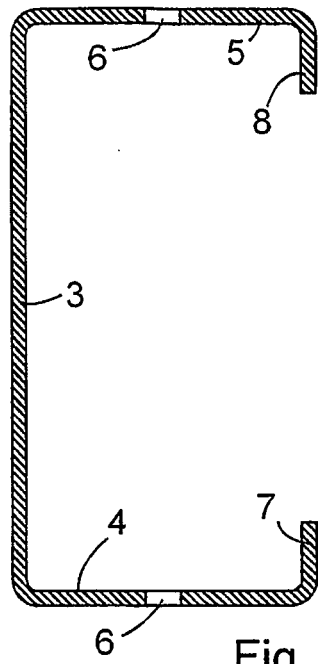

Fig. 3

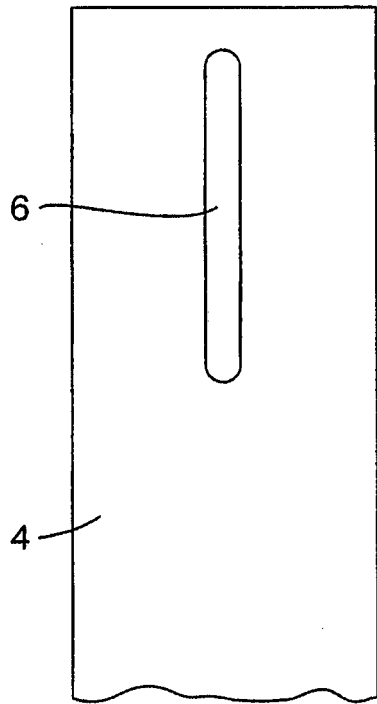

Fig. 4

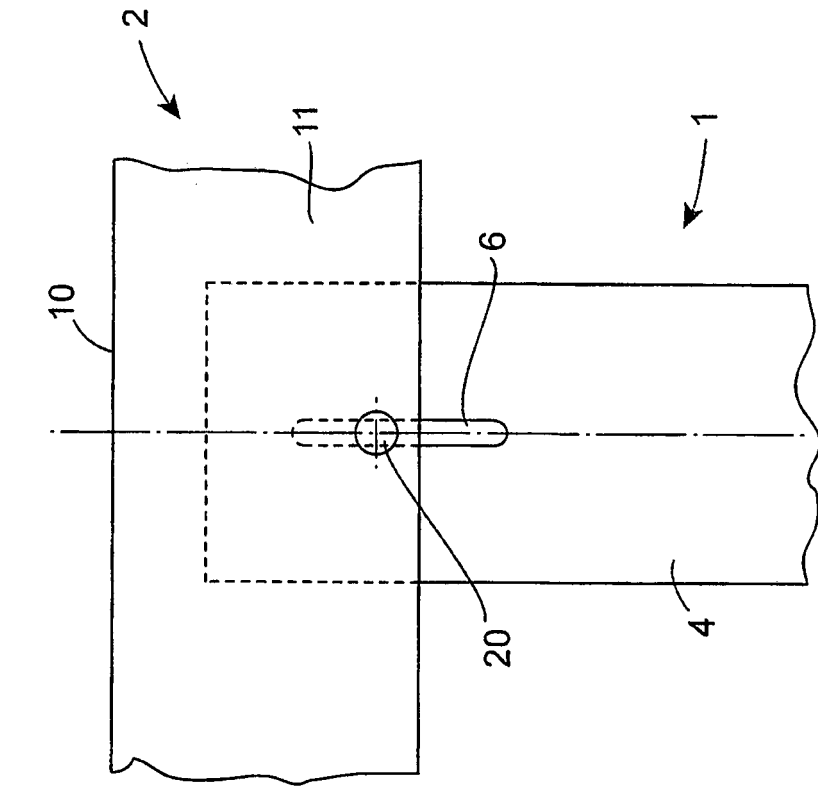

Fig. 6

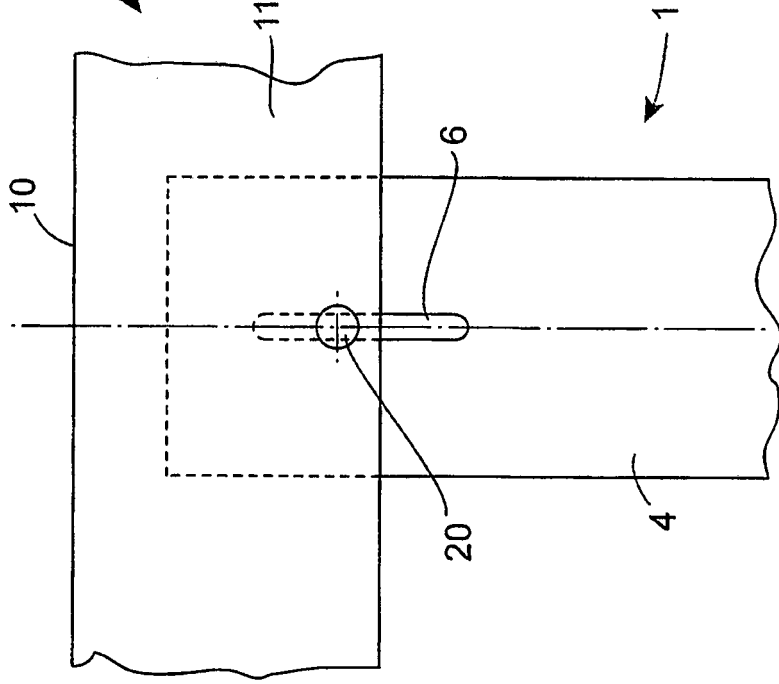

Fig. 7

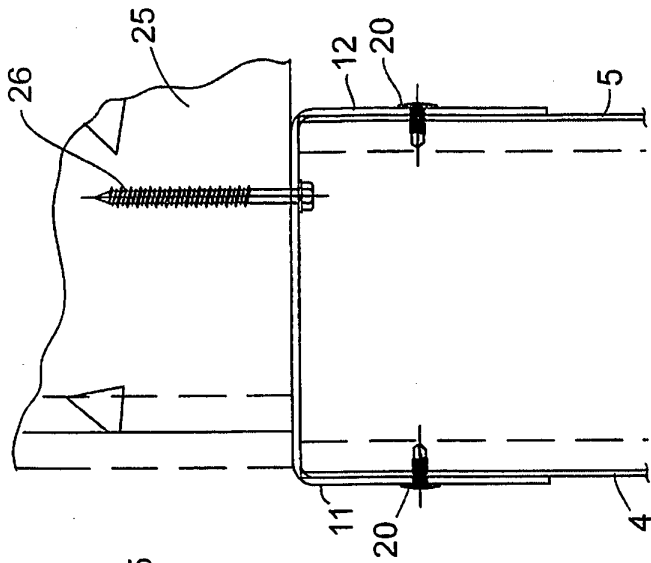

Fig. 8

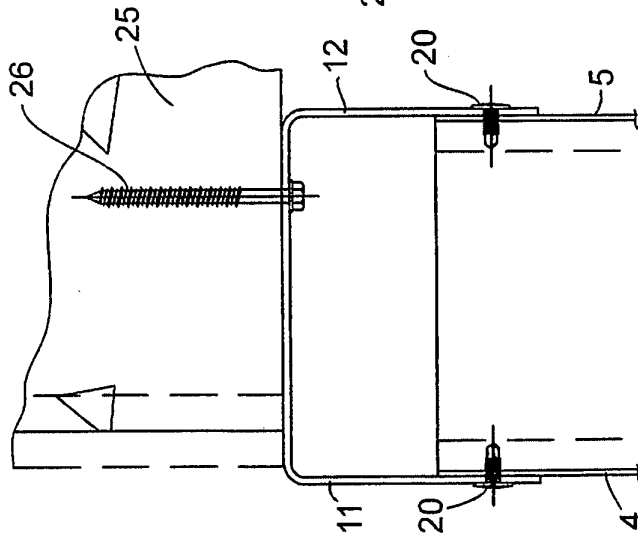

Fig. 9

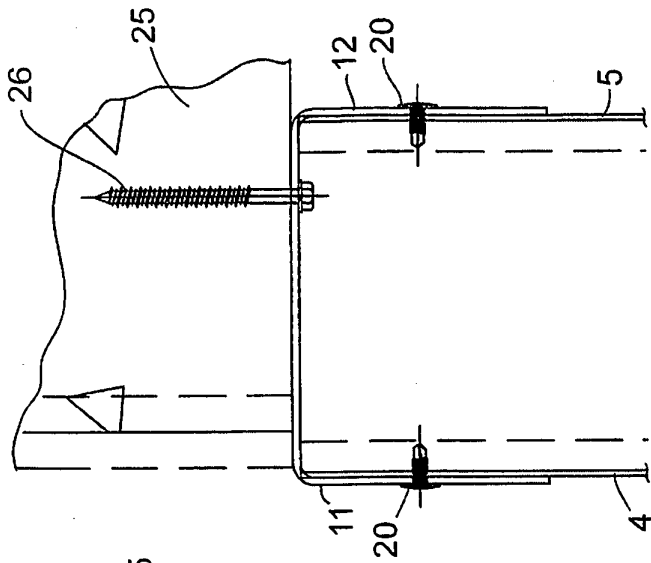
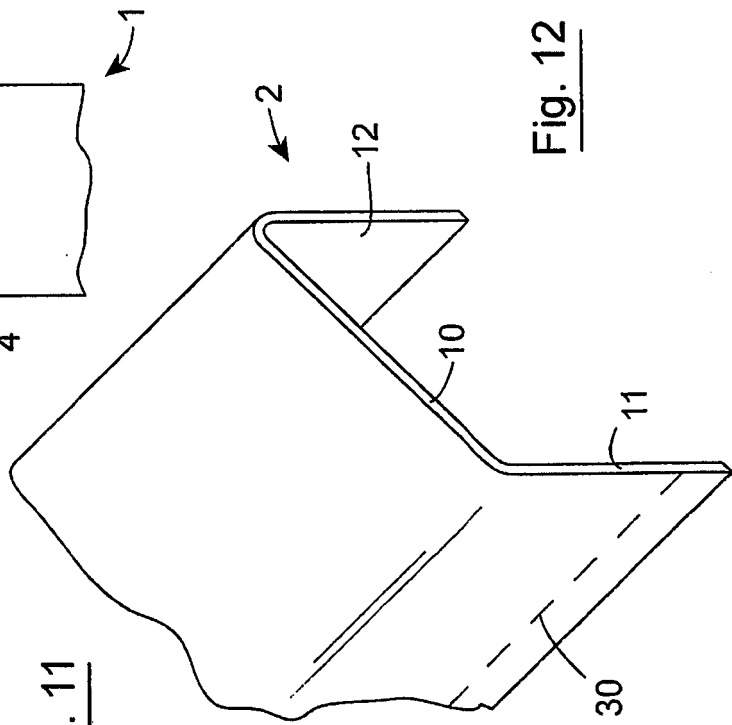
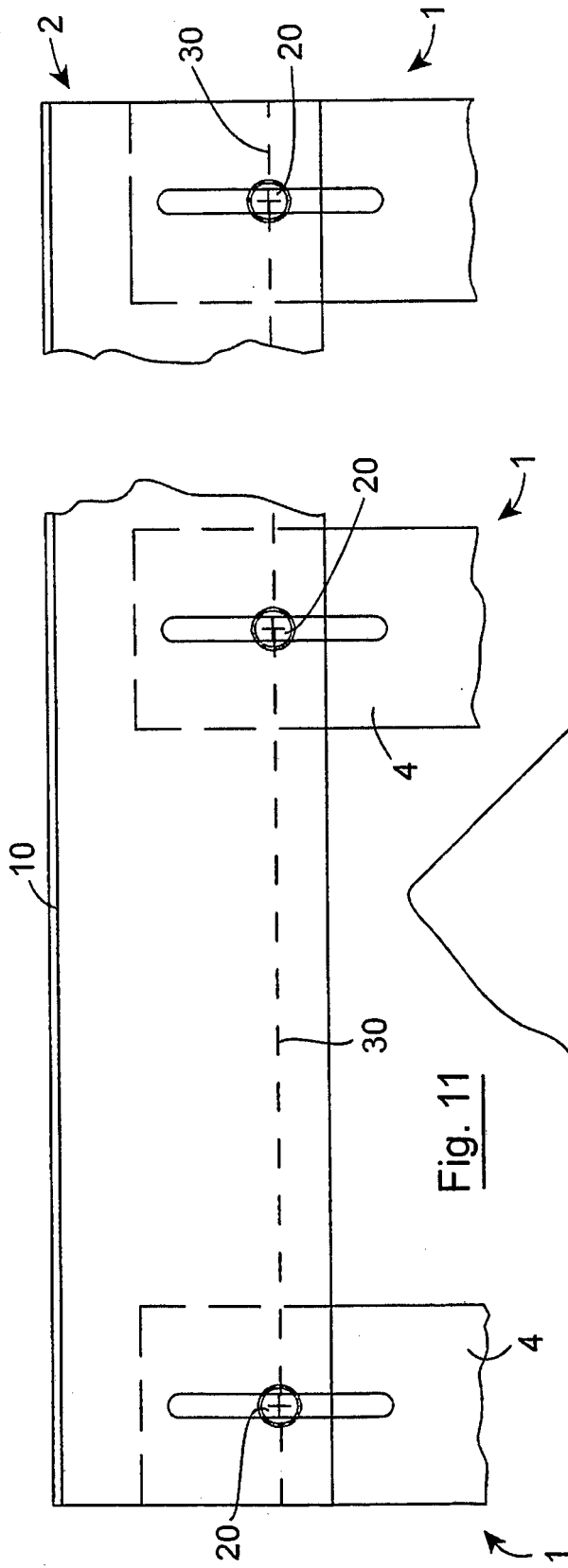

Fig. 10



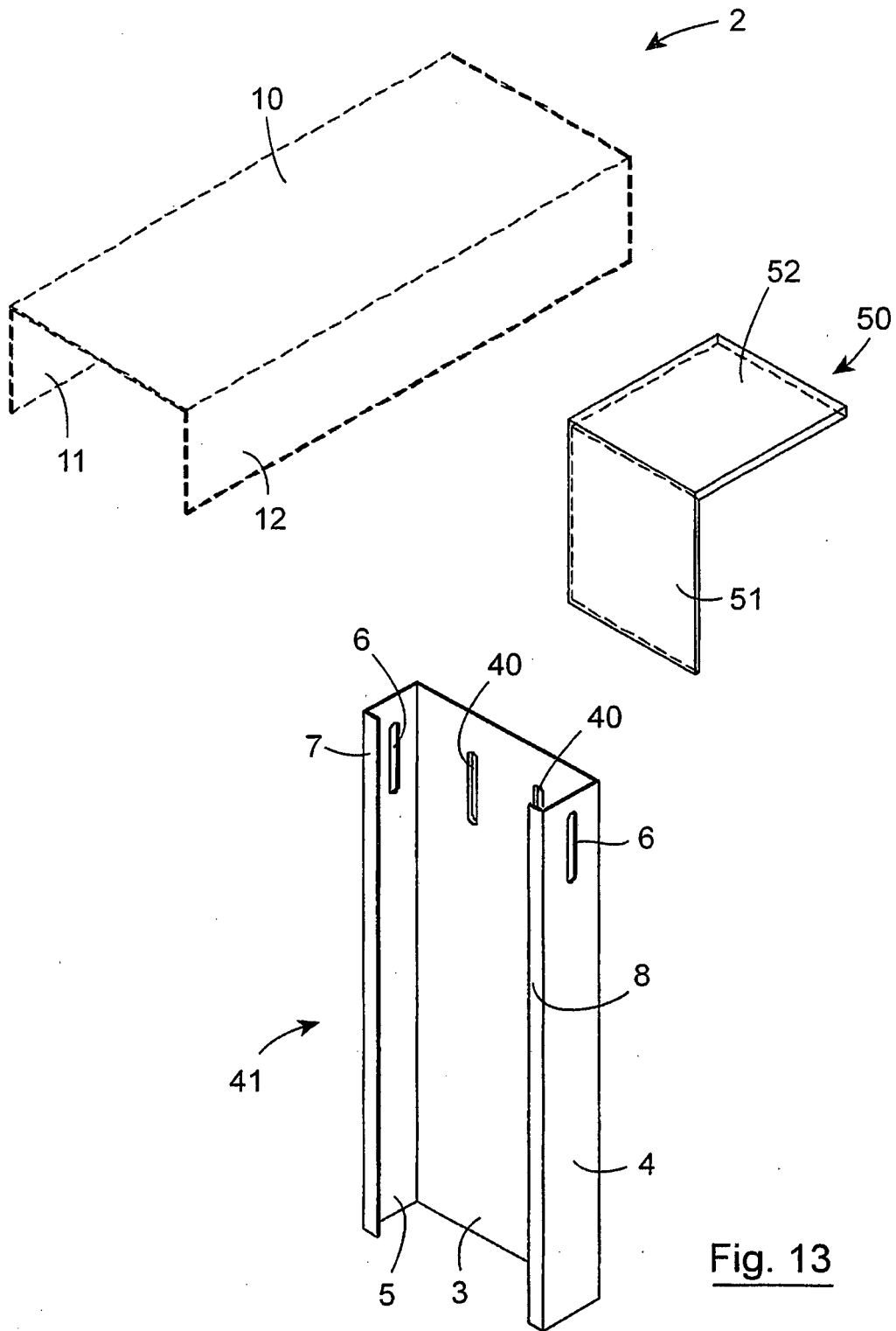

Fig. 13

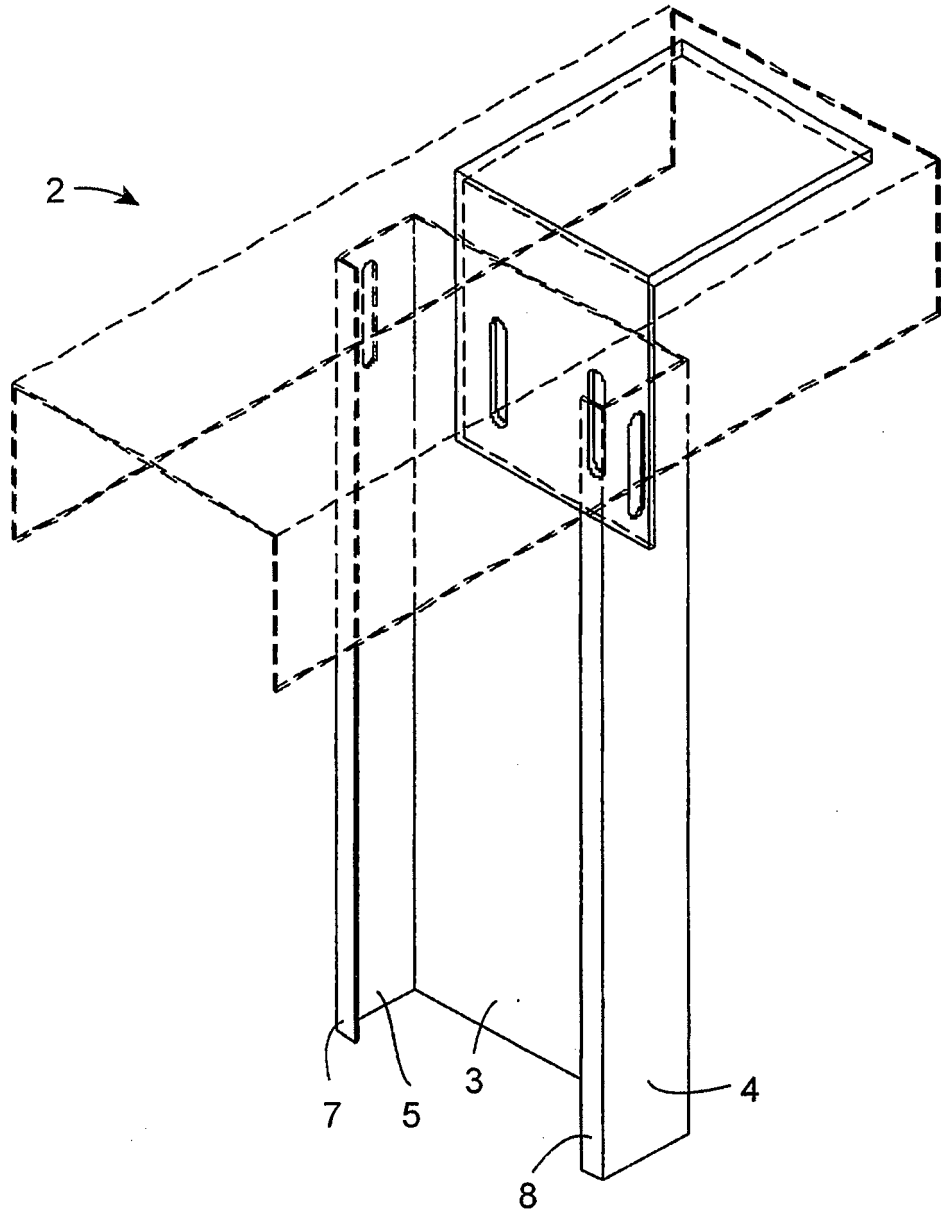

Fig. 14



Fig. 17

Fig. 16

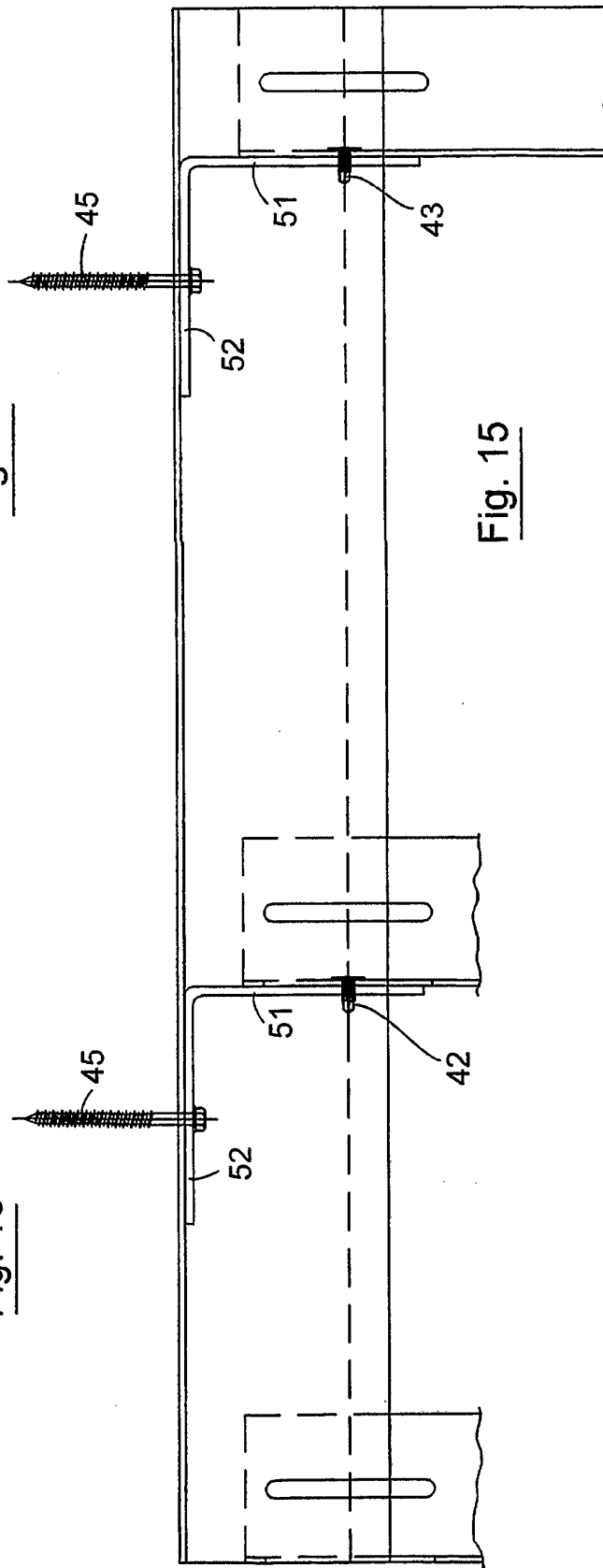

Fig. 15

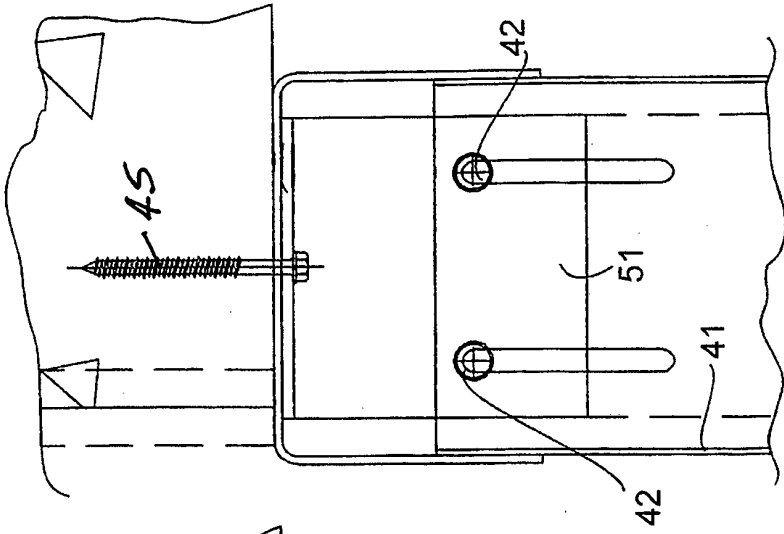

Fig. 18

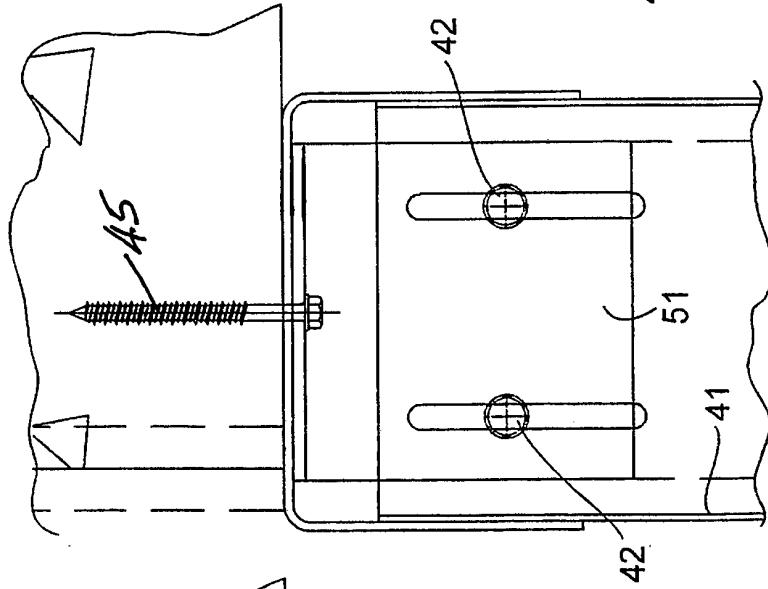

Fig. 19

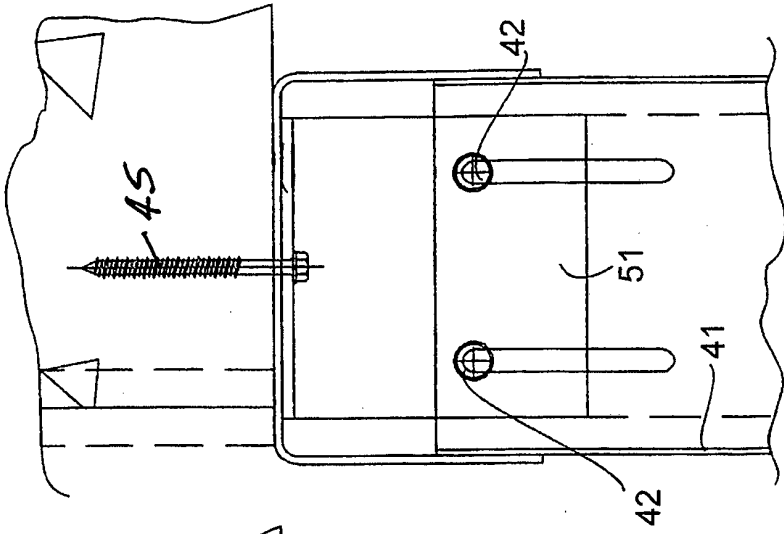

Fig. 20

REFERENCES CITED IN THE DESCRIPTION

This list of references cited by the applicant is for the reader's convenience only. It does not form part of the European patent document. Even though great care has been taken in compiling the references, errors or omissions cannot be excluded and the EPO disclaims all liability in this regard.

Patent documents cited in the description

- US 3845601 A [0001]
- US 20030196401 A [0001]
- US 20040083665 A [0001]
- US 200403336564 A [0001]