

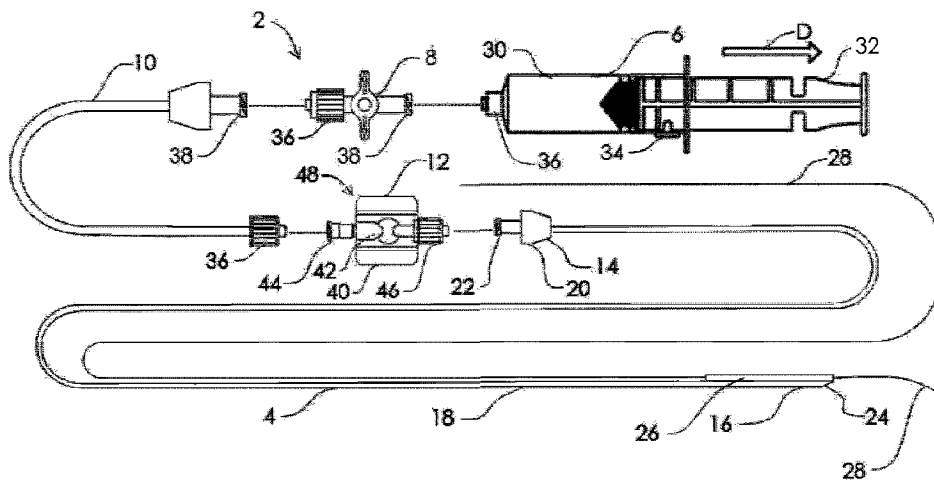

(86) Date de dépôt PCT/PCT Filing Date: 2015/04/06
 (87) Date publication PCT/PCT Publication Date: 2015/10/15
 (45) Date de délivrance/Issue Date: 2023/04/04
 (85) Entrée phase nationale/National Entry: 2016/09/06
 (86) N° demande PCT/PCT Application No.: US 2015/024569
 (87) N° publication PCT/PCT Publication No.: 2015/157191
 (30) Priorités/Priorities: 2014/04/08 (US61/976,975);
 2015/04/03 (US14/678,282)

(51) Cl.Int./Int.Cl. *A61M 25/00* (2006.01),
A61M 5/00 (2006.01)
 (72) Inventeurs/Inventors:
 LOOK, DAVID M., US;
 CULBERT, BRADLEY S., US
 (73) Propriétaire/Owner:
 INCUVATE, LLC, US
 (74) Agent: SMART & BIGGAR LP

(54) Titre : SYSTEME ET PROCEDE DE SURVEILLANCE DE L'ASPIRATION
 (54) Title: ASPIRATION MONITORING SYSTEM AND METHOD



(57) **Abrégé/Abstract:**

In one embodiment, a system for real time monitoring of catheter aspiration includes a housing having a first port adapted for connection to a vacuum source and a second port adapted for connection with an aspiration catheter, a pressure sensor in fluid communication with an interior of the housing, a measurement device coupled to the pressure sensor and configured for measuring deviations in fluid pressure, and a communication device coupled to the measurement device and configured to generate an alert signal when a deviation in fluid pressure measured by the measurement device exceeds a pre-set threshold. In another embodiment, the system for real time monitoring of catheter aspiration further includes a vacuum source for connection to the first port and an aspiration catheter having an aspiration lumen for connection to the second port.

(12) INTERNATIONAL APPLICATION PUBLISHED UNDER THE PATENT COOPERATION TREATY (PCT)

(19) World Intellectual Property
Organization
International Bureau(10) International Publication Number
WO 2015/157191 A1(43) International Publication Date
15 October 2015 (15.10.2015)

(51) International Patent Classification:

A61M 25/00 (2006.01) *A61M 5/00* (2006.01)

(21) International Application Number:

PCT/US2015/024569

(22) International Filing Date:

6 April 2015 (06.04.2015)

(25) Filing Language:

English

(26) Publication Language:

English

(30) Priority Data:

61/976,975 8 April 2014 (08.04.2014) US
14/678,282 3 April 2015 (03.04.2015) US(71) Applicant: **INCUVATE, LLC** [US/US]; 17171 Daimler St., Irvine, California 92614 (US).(72) Inventors: **LOOK, David M.**; 2018 Port Provence Pl., Newport Beach, California 92660 (US). **CULBERT, Bradley S.**; 18 Ballantree, Rancho Santa Margarita, California 92688 (US).(74) Agent: **WALKER, Blair D.**; Blair Walker IP Services, LLC, 24742 San Doval Lane, Mission Viejo, California 92691 (US).

(81) Designated States (unless otherwise indicated, for every kind of national protection available): AE, AG, AL, AM, AO, AT, AU, AZ, BA, BB, BG, BH, BN, BR, BW, BY,

BZ, CA, CH, CL, CN, CO, CR, CU, CZ, DE, DK, DM, DO, DZ, EC, EE, EG, ES, FI, GB, GD, GE, GH, GM, GT, HN, HR, HU, ID, IL, IN, IR, IS, JP, KE, KG, KN, KP, KR, KZ, LA, LC, LK, LR, LS, LU, LY, MA, MD, ME, MG, MK, MN, MW, MX, MY, MZ, NA, NG, NI, NO, NZ, OM, PA, PE, PG, PH, PL, PT, QA, RO, RS, RU, RW, SA, SC, SD, SE, SG, SK, SL, SM, ST, SV, SY, TH, TJ, TM, TN, TR, TT, TZ, UA, UG, US, UZ, VC, VN, ZA, ZM, ZW.

(84) Designated States (unless otherwise indicated, for every kind of regional protection available): ARIPO (BW, GH, GM, KE, LR, LS, MW, MZ, NA, RW, SD, SL, ST, SZ, TZ, UG, ZM, ZW), Eurasian (AM, AZ, BY, KG, KZ, RU, TJ, TM), European (AL, AT, BE, BG, CH, CY, CZ, DE, DK, EE, ES, FI, FR, GB, GR, HR, HU, IE, IS, IT, LT, LU, LV, MC, MK, MT, NL, NO, PL, PT, RO, RS, SE, SI, SK, SM, TR), OAPI (BF, BJ, CF, CG, CI, CM, GA, GN, GQ, GW, KM, ML, MR, NE, SN, TD, TG).

Declarations under Rule 4.17:

- as to applicant's entitlement to apply for and be granted a patent (Rule 4.17(ii))
- as to the applicant's entitlement to claim the priority of the earlier application (Rule 4.17(iii))

Published:

- with international search report (Art. 21(3))

(54) Title: ASPIRATION MONITORING SYSTEM AND METHOD

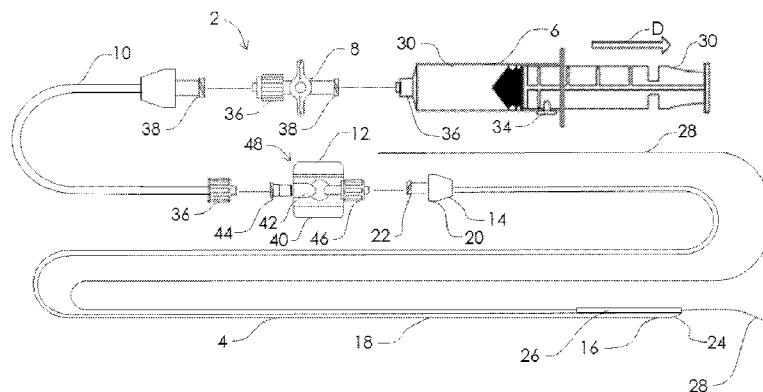

FIG. 1

(57) Abstract: In one embodiment, a system for real time monitoring of catheter aspiration includes a housing having a first port adapted for connection to a vacuum source and a second port adapted for connection with an aspiration catheter, a pressure sensor in fluid communication with an interior of the housing, a measurement device coupled to the pressure sensor and configured for measuring deviations in fluid pressure, and a communication device coupled to the measurement device and configured to generate an alert signal when a deviation in fluid pressure measured by the measurement device exceeds a pre-set threshold. In another embodiment, the system for real time monitoring of catheter aspiration further includes a vacuum source for connection to the first port and an aspiration catheter having an aspiration lumen for connection to the second port.

WO 2015/157191 A1

ASPIRATION MONITORING SYSTEM AND METHOD

BACKGROUND OF THE INVENTION

Field of the Invention

[0001] The field of the invention generally relates to an aspiration system for removing, by aspiration, undesired matter such as a thrombus from a fluid carrying cavity, duct, or lumen of the body, such as a blood vessel.

Description of the Related Art

[0002] A treatment method for removing undesired matter such as thrombus from a blood vessel of a patient involves use of an aspiration catheter having elongate shaft formed with an aspiration lumen extending therein. An aspiration catheter may also include a guidewire lumen for placement of a guidewire, which is used to guide the aspiration catheter to a target site in the body. By applying a vacuum (i.e. negative pressure) to a proximal end of the aspiration lumen, for example, with a syringe having a hub that is connected to the proximal end of the aspiration catheter, the matter can be aspirated into an aspiration port at the distal end of the aspiration catheter, into the aspiration lumen, and thus be removed from the patient.

SUMMARY OF THE INVENTION

[0003] In one embodiment, a system for real time monitoring of catheter aspiration includes a vacuum source, an aspiration catheter having an aspiration lumen, a housing having a first port configured to couple to the vacuum source and a second port configured to couple to the aspiration lumen of the aspiration catheter, a pressure sensor in fluid communication with an interior of the housing, a measurement device coupled to the pressure sensor and configured for measuring deviations in fluid pressure, and a communication device coupled to the measurement device and configured to generate an alert when a deviation in fluid pressure measured by the measurement device exceeds a pre-set threshold.

[0004] In another embodiment, a system for real time monitoring of catheter aspiration includes a housing having a first port adapted for detachable connection to a vacuum source and a second port adapted for detachable connection with an aspiration catheter, a pressure sensor in fluid communication with an interior of the housing, a

measurement device coupled to the pressure sensor and configured for measuring deviations in fluid pressure, and a communication device coupled to the measurement device and configured to generate an alert signal when a deviation in fluid pressure measured by the measurement device exceeds a pre-set threshold.

[0005] In another embodiment, a method for real time monitoring of catheter aspiration includes the steps of inserting an aspiration catheter having an aspiration lumen into a patient, providing a system for real time monitoring of catheter aspiration, the system including a housing having a first port adapted for detachable connection to a vacuum source and a second port adapted for detachable connection with the aspiration lumen of the aspiration catheter, a pressure sensor in fluid communication with an interior of the housing, a measurement device coupled to the pressure sensor and configured for measuring deviations in fluid pressure, and a communication device coupled to the measurement device and configured to generate an alert signal when a deviation in fluid pressure measured by the measurement device exceeds a pre-set threshold, coupling the first port to a vacuum source, coupling the second port to the aspiration lumen of the aspiration catheter, and causing or allowing a body fluid to be aspirated through the aspiration lumen of the aspiration catheter, wherein the measurement device measures fluid pressure during aspiration of the body fluid, and wherein the communication device generates an alert signal when one or more measured deviations in fluid pressure exceed a pre-set threshold during the aspiration of the body fluid.

[0005a] According to one embodiment of the present invention, there is provided a system for real time monitoring of catheter aspiration, comprising: a housing having a first port adapted for detachable connection to a vacuum source and a second port adapted for detachable connection with an aspiration catheter, the housing having an interior configured for liquid to pass therethrough; a pressure sensor in fluid communication with the interior of the housing; a measurement device coupled to the pressure sensor and configured for measuring deviations in fluid pressure; and a communication device coupled to the measurement device and configured to generate an alert signal when a deviation in fluid pressure measured by the measurement device exceeds a pre-set threshold.

[0005b] According to another embodiment of the present invention, there is provided a self-contained monitoring device for real time monitoring of catheter aspiration, configured for connection in between an aspiration catheter and a vacuum source, comprising: a housing having a first port adapted for connection to a vacuum source and a second port adapted for connection to an aspiration catheter, the housing having an interior configured for liquid to pass therethrough; a pressure sensor in fluid communication with the interior of the housing, the pressure sensor configured to measure negative pressure; a measurement device coupled to the pressure sensor and configured for measuring deviations in negative fluid pressure; and a communication device coupled to the measurement device and configured to generate an alert signal when a deviation in fluid pressure measured by the measurement device exceeds a pre-set threshold.

[0005c] According to still another embodiment of the present invention, there is provided a system for real time monitoring of catheter aspiration, comprising: an aspiration catheter having a proximal end, a distal end, and an aspiration lumen extending therebetween, the distal end of the aspiration catheter configured for placement within the vasculature of a subject; and a monitoring device comprising: a first sensor configured to be carried on the aspiration catheter, and further configured to monitor a flow condition related to flow through the aspiration lumen of the aspiration catheter, the first sensor configured to measure negative pressure; a measurement device coupled to the first sensor and configured for measuring deviations output by the first sensor; and a communication device coupled to the measurement device and configured to generate a first alert when a deviation measured by the measurement device exceeds a pre-set threshold, the first alert indicative of the aspiration status of the system.

[0005d] According to yet another embodiment of the present invention, there is provided a monitoring device for real time monitoring of catheter aspiration, comprising: a housing having a first port adapted for connection to a vacuum source; a pressure sensor in fluid communication with an interior of the housing; a measurement device coupled to the pressure sensor and configured for measuring deviations in fluid pressure; and a communication device coupled to the measurement device and configured to generate an alert signal when a deviation in fluid pressure measured by the measurement device exceeds a pre-set threshold, wherein the communication device is configured to generate a

first type of alert in response to a deviation measured by the measurement device comprising an increase and decrease of vacuum pressure, wherein the increase and decrease of vacuum pressure comprises a baseline vacuum pressure and a peak vacuum pressure, and wherein the pre-set threshold is compared to a difference between the peak vacuum pressure and the baseline vacuum pressure.

[0005e] According to a further embodiment of the present invention, there is provided a monitoring device for real time monitoring of catheter aspiration, comprising: a housing having a first port adapted for connection to a vacuum source, the housing having an interior configured for liquid to pass therethrough; a pressure sensor disposed within the interior of the housing, the pressure sensor configured to measure negative pressure; a measurement device coupled to the pressure sensor and configured for measuring deviations in negative fluid pressure; and a communication device coupled to the measurement device and configured to generate an alert signal when a deviation in fluid pressure measured by the measurement device exceeds a pre-set threshold.

[0005f] According to a further embodiment of the present invention, there is provided a monitoring device for real time monitoring of catheter aspiration, comprising: a housing having a first port adapted for connection to a vacuum source; a pressure sensor disposed within an interior of the housing; a measurement device coupled to the pressure sensor and configured for measuring deviations in fluid pressure; and a communication device coupled to the measurement device and configured to generate an alert signal when a deviation in fluid pressure measured by the measurement device exceeds a pre-set threshold, wherein the communication device is configured to generate a first type of alert in response to a deviation measured by the measurement device comprising an increase and decrease of vacuum pressure, wherein the increase and decrease of vacuum pressure comprises a baseline vacuum pressure and a peak vacuum pressure, and wherein the pre-set threshold is compared to a difference between the peak vacuum pressure and the baseline vacuum pressure.

BRIEF DESCRIPTION OF THE DRAWINGS

[0006] FIG. 1 is a plan view of a system for aspiration according to an embodiment.

[0007] FIG. 2A is a view of an aspiration monitoring system according to a first embodiment.

[0008] FIG. 2B is a view of an aspiration monitoring system according to a second embodiment.

[0009] FIG. 3 is a view of an aspiration monitoring system according to a third embodiment.

[0010] FIG. 4A is a sectional view of an aspiration catheter in a blood vessel prior to contact with a thrombus.

[0011] FIG. 4B is a sectional view of an aspiration catheter in a blood vessel upon contact with a thrombus.

[0012] FIG. 4C is a sectional view of an aspiration catheter during a loss of vacuum.

[0013] FIG. 4D is a sectional view of thrombi being aspirated through an aspiration catheter.

[0014] FIG. 5A is a graphic representation of pressure vs. time for the condition of FIG. 4A.

[0015] FIG. 5B is a graphic representation of pressure vs. time for the condition of FIG. 4B.

[0016] FIG. 5C is a graphic representation of pressure vs. time for the condition of FIG. 4C.

[0017] FIG. 5D is a graphic representation of pressure vs. time for the condition of FIG. 4D.

DETAILED DESCRIPTION OF THE ILLUSTRATED EMBODIMENTS

[0018] The present invention relates to a monitoring, warning and communication system for aspiration catheter systems. Clogging of aspiration catheters, for example by large pieces of thrombus, is a common concern for users. Techniques to avoid clogging/choking of material within the catheter often involve rapidly, aggressively advancing the aspiration catheter or gently plucking at edges of a thrombus to insure only small pieces or portions are introduced at a time, pieces which are small enough to not clog or occlude the aspiration lumen. When a device becomes clogged during use, the potential for inadvertent dislodgment of thrombus downstream increases; this is referred to as distal embolism. As aspiration procedures of this type are often used in highly technical emergent settings, early clog detection of the aspiration catheter for the user during aspiration can contribute to the success of the procedure and clinical outcome. Some sources have reported that up to 50% of aspiration catheters used get clogged during use.

[0019] Additionally, the user may have difficulty determining whether there has been a loss of vacuum in the system, for example because of the syringe (or other vacuum source) being full of fluid or because of a leak in the system. Blood is relatively opaque and can coat the wall of the syringe, thus making it difficult to determine when the syringe becomes full. This makes it difficult to determine whether sufficient vacuum is being applied to the aspiration catheter. It is also difficult to determine whether there is an air leak in the system, which can be another cause for a loss of vacuum even before the syringe becomes full of the aspirated fluid.

[0020] During the aspiration of thrombus with an aspiration catheter, it is difficult to identify when thrombus is actively being aspirated, and when only blood is being aspirated. Typically it is desired to not aspirate sizable quantities of normal blood from blood vessels, because of the importance of maintaining normal blood volume and blood pressure. However, when tracking the tip of an aspiration catheter in proximity to a thrombus, it is difficult to know whether the aspiration catheter has actively engaged a thrombus, whether it has aspirated at least a portion of the thrombus, or whether it is not engaged with the thrombus, and is only aspirating blood. The use of aspiration catheters can therefore be inefficient, and cause more blood removal than desired, causing a user to minimize the length of the therapy and in severe cases necessitating blood transfusion. An increased volume of normal blood being aspirated also means that the vacuum source (e.g. syringe) will fill in a shorter amount of time, thus required more frequent replacement of the vacuum source. Distal embolism may occur if the vacuum pressure is not sufficient, and yet the user is not aware.

[0021] An aspiration system 2 is illustrated in FIG. 1 and is configured to allow real time monitoring of catheter aspiration. The aspiration system 2 comprises an aspiration catheter 4, a vacuum source 6, a valve 8, extension tubing 10, and an aspiration monitoring system 48 including an in-line pressure transducer 12. The aspiration catheter 4 has a proximal end 14 and a distal end 16 and an aspiration lumen 18 extending from the proximal end 14 to the distal end 16. The aspiration lumen 18 may be sized for aspiration of thrombus, and in some embodiments may have an inner diameter of between about 0.38 millimeter (0.015 inches) and about 2.54 millimeters (0.100 inches). The aspiration catheter 4 includes a hub 20 at its proximal end which may include a female luer connector 22. The aspiration lumen 18 at the distal end 16 of the aspiration catheter 4 may include an angled orifice 24, which aids in the tracking through tortuous or occluded vasculature. In some embodiments, a guidewire lumen 26 is coupled to the distal end 16 of the aspiration catheter 4, and is configured to track over a guidewire 28. The vacuum source 6 may comprise a syringe, and may be sized between 5 ml and 100 ml, or between 20 ml and 60. The vacuum source 6 may comprise a VacLok® syringe, made by Merit Medical, Salt Lake City, Utah. The vacuum source 6 may include a barrel 30 and plunger 32, with a lock 34 which is configured to retain the plunger 32 in position in relation to the barrel 30, for example, when the plunger is pulled back in direction D to create a negative pressure (vacuum) inside the barrel 30. In some embodiments, the vacuum source 6 may comprise any other type of evacuable reservoir, or may comprise a vacuum pump. The vacuum source 6 is connected to the aspiration lumen 18

of the aspiration catheter 4 via the extension tubing 10 and the valve 8. In some embodiments, the vacuum source 6 may be connected directly to the aspiration lumen 18 of the aspiration catheter 4. Male luer connectors 36 and female luer connectors 38 are indicated in FIG. 1. The valve 8 may be a standard two-way stopcock, as illustrated.

[0022] The pressure transducer 12 of the aspiration monitoring system 48 is configured to be fluidly coupled between the vacuum source 6 and the aspiration catheter 4. In FIG. 2A, the aspiration monitoring system 48 is illustrated as a self-contained device of a first embodiment. The pressure transducer 12 comprises a housing 40 having a cavity 42 extending between a first port 44 and a second port 46. In some embodiments, the first port 44 comprises a female luer and the second port 46 comprises a male luer. In some embodiments, the first port 44 comprises a female luer lock and the second port 46 comprises a male luer lock, each of which is attachable to and detachable from a corresponding luer lock of the opposite gender. The first port 44 is configured to be coupled to the vacuum source 6, either directly, or with the valve 8 and/or extension tubing 10 connected in between. The second port 46 is configured to be coupled to the aspiration lumen 18 of the aspiration catheter 4, for example, by coupling the second port 46 directly or indirectly to the hub 20 of the aspiration catheter 4. When the aspiration system 2 is used to aspirate body fluids and/or materials, for example blood and/or thrombus, the body fluids and/or materials are aspirated through the aspiration lumen 18 of the aspiration catheter from the angled orifice 24 at the distal end 16 to the female luer connector 22 at the proximal end 14, then pass through the second port 46 of the pressure transducer 12 first, through the cavity 42, and then through the first port 44. Depending on the amount of amount of vacuum (negative pressure) applied by the vacuum source 6, and the amount of flow resistance and resulting pressure drop along the aspiration system 2, the pressure within the cavity 42 will vary. For example, a more viscous fluid like blood, or a fluid having solid, semi-solid, or gel-like particles or portions, will cause more flow resistance through the relatively small aspiration lumen 18 of the aspiration catheter 4 than would water or normal saline solution. Thus the pressure within the cavity 42 of the pressure transducer 12 will decrease (the amount of vacuum will increase) as the flow resistance in the aspiration lumen 18 increases.

[0023] For definition purposes, when speaking of the amount of vacuum, a pressure of, for example, -15,000 pascal (-2.18 pounds per square inch, or psi) is a “larger vacuum” than -10,000 pascal (-1.45 psi). Additionally, -15,000 pascal is a “lower pressure” than -10,000 pascal. Furthermore, -15,000 pascal has a larger “absolute vacuum pressure” than does -10,000 pascal, because the absolute value of -15,000 is larger than the absolute

value of -10,000. In FIG. 2A, a vacuum sensor 50 is disposed within the cavity 42 of the housing 40 and is in fluid communication with fluid that passes through the cavity 42. The vacuum sensor 50 may be a standard pressure sensor or transducer, including a pressure sensor designed primarily for measuring positive pressure. It may use any type of pressure sensing technology known in the art, including MEMS Technology. In some embodiments, the vacuum sensor 50 is configured for highest accuracy and/or precision within the range of pressures between about 0 pascal to about -101,325 pascal (-14.70 psi), or between about -45,000 pascal (-6.53 psi) and about -90,000 pascal (-13.05 psi), or between about -83,737 pascal (-12 psi) and about -96,527 pascal (-14 psi). In some embodiments, the power requirement for the vacuum sensor may range from 2.5 volts DC to 10 volts DC. In some embodiments, the vacuum sensor 50 may be an analog gauge with an output voltage. In the self-contained embodiment of the FIG. 2A, the vacuum sensor 50 is powered by one or more battery 52. Based on the power requirements of the vacuum sensor 50, and the power requirements of other components of the aspiration monitoring system 48 described herein, in some embodiments the one or more battery 52 may range between 1.5 volts and nine volts. Also contained within the housing is a measurement device 54, which in some embodiments may comprise a microprocessor. The measurement device 54 is coupled to the vacuum sensor 50 and receives signals from the vacuum sensor 50 indicative of real time measured pressure. In some embodiments, the measurement device 54 includes a memory module 56 in which information is stored that may be used by the measurement device 54, for example, in calculations.

[0024] One or more communication devices 58a, 58b, 58c are included within the aspiration monitoring system 48 and are coupled to the measurement device 54. Each of the one or more communication devices 58a-c are configured to generate a type of alert comprising an alert signal 60a-c, in response at least in part to activity and output of the measurement device 54. In some embodiments, the communication device 58a may include one or more LEDs (light emitting diodes) configured to generate a visible alert via a visible alert signal 60a, such as light that is continuously illuminated, or is illuminated in a blinking pattern. In some embodiments, lights other than LEDs may be used. In some embodiments, the communication device 58b may include one or more vibration generators configured to generate a tactile alert via a tactile alert signal 60b, which may include, but is not limited to, vibration or heat. In some embodiments, the vibration generator may comprise a piezoelectric device which is configured to vibrate when a voltage is applied. In some embodiments, the communication device 58c may include one or more sound generating devices configured to

generate an audible alert via an audible alert signal 60c, such as a continuous noise, or a repeating noise. In some embodiments, the sound generating device may comprise a buzzer which is configured to sound one or more audible pitches when a voltage is applied. In some embodiments a piezoelectric device, such as that described in relation to the communication device 58b may also serve as a sound generating device, included as communication device 58c.

[0025] A user of an aspiration system 2 may desire to be notified of several conditions which may occur during use of the aspiration system 2. These potential conditions include, but are not limited to clogging, a loss of vacuum due to filling of the vacuum source 6 and or a breach, break or puncture in the aspiration system 2, and the engagement or aspiration of non-fluid, solid or semi-solid material such as thrombus. The aspiration monitoring system 48 of FIG. 2A is configured to alert users of an aspiration system 2 about real time status of the aspiration system 2, including operational conditions, which include: whether vacuum is being applied or not; flow conditions, which include whether a thrombus is engaged, whether a thrombus is being actively aspirated, whether the system is leaking air, whether the system is clogged, whether the vacuum source 6 is full and/or needs to be changed; or other potential set up issues. The real time feedback provided frees a user or operator from the need of excessive personal monitoring of the vacuum source 6, extension tubing 10, or other portions of the aspiration system 2, for improper or undesired flow or operation conditions, and thus allows the user to focus more attention on the patient being treated.

[0026] The pressure transducer 12 of the aspiration monitoring system 48 is configured to continuously measure and monitor the absolute pressure amplitude within the closed system of the aspiration system 2, and also is configured to measure and monitor the relative pressure over time to detect noteworthy flow changes within the flow circuit of the aspiration system 2. Some changes are discernible via absolute pressure measurement, while more subtle pressure deflections may be compared to a stored library in memory. Noteworthy conditions may be signaled to the user when appropriate. In some embodiments, the unfiltered signal may be amplified by an amplifier and filtered by a filter, for example, to increase the signal-to-noise ratio. Examples of the (background) noise 57 in an unfiltered signal can be seen in FIGS. 5A-5D (labeled in FIG. 5A). In some embodiments, one or more algorithms may be used, as described herein, to identify particular conditions of interest.

[0027] FIG. 2B illustrates a second embodiment of an aspiration monitoring system 62 having a pressure transducer 12 having a vacuum sensor 50 disposed within the

cavity 42 of a housing 40. The vacuum sensor 50 may be powered by at least one battery 52. In some embodiments, the pressure transducer 12 may be reusable, and may be configured to allow charging of the battery 52, or of a capacitor (not shown) by direct charging methods, or by inductive power transfer methods and devices known in the art. Unlike the aspiration monitoring system 48 of FIG. 2A, the aspiration monitoring system 62 of FIG. 2B comprises a measurement device 64, memory module 66, and communication device 68 which are external to the pressure transducer 12. A power module 72, also external, may be used to power any of the measurement device 64, memory module 66, or communication device 68. The communication device 68 may be any of the communication device 58a, 58b, 58c described in relation to the aspiration monitoring system 48 of FIG. 2A, and are configured to product an alert via an alert signal 70. The communication device 68 may be portable so that it may be positioned close to the user.

[0028] In some embodiments, the communication device 68 may be wearable by the user. FIG. 3 illustrates an aspiration monitoring system 78 which includes an antenna 80 coupled to a measurement device 76. The measurement device 76 is similar to the measurement device 54 of prior embodiments, except that it wirelessly sends a communication signal 84 via the antenna 80 to a corresponding antenna 82 of a communication device 74. In some embodiments, the communication device 74 comprises a wristband which the user wears, and which may include a vibration generator or heat generator. In some embodiments, the communication device 74 comprises an audio speaker which may be attached to equipment or even to the patient or user. In some embodiments, the communication device 74 comprises an audio speaker on an earpiece or earbud that the user may wear. In some embodiments, Bluetooth® communication technology may be used.

[0029] FIG. 4A illustrates the distal end 16 of an aspiration catheter 4 within a blood vessel 86 having at least one thrombus 88. The aspiration catheter 4 is being advanced in a forward direction F, but the distal end 16 of the aspiration catheter 4 has not yet reached the proximal extremity 94 of the thrombus 88. A vacuum source 6 (FIG. 1) has been coupled to the aspiration lumen 18 of the aspiration catheter 4 and activated (i.e. the valve 8 is open) causing blood 96 to be aspirated into the aspiration lumen 18 (arrows A). Turning to FIG. 5A, a corresponding curve 98 is represented for the normal fluid (e.g. blood) vacuum over time for the condition of FIG. 4A. The curve 98 represents vacuum pressure over time sensed by the vacuum sensor 50 of any of the embodiments presented. No leaks are present and no thrombus is being evacuated, and therefore the curve 98 includes a downward slope 99 when the vacuum source 6 increases the vacuum up (lowers the pressure) within the cavity 42 of

the pressure transducer 12 to a relatively steady state. The steady pressure curve 97 continues while blood 96 is being aspirated. As the vacuum is decoupled from the aspiration lumen 18, for example by closing the valve 8 or by detaching any two of the ports (e.g. luers), or if the vacuum source 6 fills completely with blood 96, then an upward slope 95 is measured.

[0030] The measurement device 54, 64 is configured to compare the curve 97 with information stored in the memory module 56, 66 to identify this condition. In some embodiments, the measurement device 54, 64 uses an algorithm to make the comparison. In some embodiments, the measurement device 54, 64 then sends a signal to the communication device 58a-c, 74, and the communication device 58a-c, 74 generates an appropriate alert. Communication device 58a, for example a particular color LED, may be illuminated, or an LED may flash in a particular pattern or number of flashes. Communication device 58b may create a characteristic sound, or may generate an audio message in a number of languages. For example, the audio message may state, “Thrombus encountered,” or “No thrombus encountered.” Communication device 58c may vibrate or heat in a characteristic pattern, for example, a certain number of repetitions or a certain frequency between repetitions. The user may determine that an additional fluoroscopic image (e.g. angiography) or other imaging modalities may be necessary to better identify the location of the thrombus 88.

[0031] FIG. 4B illustrates the distal end 16 of an aspiration catheter 4 advanced to a position such that the distal end 16 of the aspiration catheter 4 contacts the proximal extremity 94 of the thrombus 88. The corresponding curve 93 in FIG. 5B represents vacuum pressure over time sensed by the vacuum sensor 50 of any of the embodiments presented. The curve 93 initially has a downward slope 99 followed by a steady pressure curve 97, as in the condition of FIG. 4A, graphed in FIG. 5A, however, when the distal end 16 of the aspiration catheter 4 contacts the proximal extremity 94 of the thrombus 88, if the aspiration causes a portion of the thrombus 88 (for example a large or relatively hard portion) to enter and become trapped in the aspiration lumen 18, then a clog condition occurs. A similar condition occurs if the distal end 16 of the aspiration catheter 4 is caught on the thrombus 88 by the vacuum, with virtually nothing flowing through the aspiration lumen 18. In either condition, the curve 93 includes a deviation (or disturbance) in fluid pressure 91. If the clog (or stuck condition) continues, then a flat, depressed pressure 89 is measured.

[0032] The measurement device 54, 64 is configured to compare the curve 93 with information stored in the memory module 56, 66 to identify this condition. In some embodiments, the measurement device 54, 64 uses an algorithm to make the comparison. In some embodiments, a pre-set pressure differential ΔP_1 may be stored in the memory module

56, 66 as a threshold, whereby the measurement of a pressure difference 81 less than this threshold does not result in the measurement device 54, 64 commanding the communication device 58a-c, 74 to send an alert signal 60a-c, 70. In some embodiments, when the pressure difference 81 is greater than (or greater than or equal to) the pre-set pressure differential ΔP_1 , the measurement device 54, 64 then sends a signal to the communication device 58a-c, 74, and the communication device 58a-c, 74 generates an appropriate alert. Communication device 58a, for example a particular color LED, may be illuminated, or an LED may flash in a particular pattern or number of flashes. Communication device 58b may create a characteristic sound, or may generate an audio message in a number of languages. For example, the audio message may state, "Clog Condition." Communication device 58c may vibrate or heat in a characteristic pattern, for example, a certain number of repetitions or a certain frequency between repetitions. When the user realizes that the clog condition is present, the user may pull on the aspiration catheter 4 and readvance it, in an attempt to contact a portion of the thrombus 88 that can be aspirated. If a portion of the thrombus is clogged in the aspiration lumen 18, and repositioning of the aspiration catheter 4 does not produce good results, the aspiration catheter 4 can be removed and the aspiration system 2 can be repurged, for example by a positive pressurization.

[0033] FIG. 4C illustrates the distal end 16 of the aspiration catheter 4 in a general situation during which a breach in the aspiration system 2 has occurred. For example, a break, leak, puncture, pinhole, loosening, or disconnection may cause air to be pulled into the aspiration lumen 18 of the aspiration catheter 4, the cavity 42 of the pressure transducer 12, of the interior of the extension tubing 10, valve 8, or vacuum source 6. As graphed in the curve 85 of FIG. 5C, a downward slope 99 and a subsequent steady pressure curve 97 are measured, but at the point in time of the breach 87 an upward slope 83 begins.

[0034] The measurement device 54, 64 is configured to compare the curve 85 with information stored in the memory module 56, 66 to identify this condition. In some embodiments, the measurement device 54, 64 uses an algorithm to make the comparison. In some embodiments, the measurement device 54, 64 then sends a signal to the communication device 58a-c, 74, and the communication device 58a-c, 74 generates an appropriate alert. Communication device 58a, for example a particular color LED, may be illuminated, or an LED may flash in a particular pattern or number of flashes. Communication device 58b may create a characteristic sound, or may generate an audio message in a number of languages. For example, the audio message may state, "System Leak." Communication device 58c may vibrate or heat in a characteristic pattern, for example, a certain number of repetitions or a

certain frequency between repetitions. Upon receiving the alert, the user will check the components of the aspiration system 2 and either fix the breach or replace one or more of the components of the aspiration system 2. For example, in some cases, the communication device 58a-c, 74 may alert the user when the measurement device 54, 64 confirms a loss of vacuum, allowing the user to change or recharge the vacuum source 6, which has become depleted (e.g. by filling with blood and/or thrombus).

[0035] FIG. 4D illustrates the distal end 16 of the aspiration catheter 4 during the successful aspiration of pieces or portions 90 of the thrombus 88. In some cases, the pieces or portions 90 may follow a tortuous path 92, due to disturbances or collisions with the inner wall of the aspiration lumen 18 while being pulled through the aspiration lumen 18. In some cases, the pieces or portions 90 may catch and slip within the inner wall of the aspiration lumen 18, for example, do to variance of the inner diameter of the aspiration lumen 18 along the length. Either of these situations can cause a corresponding series of increases and decreases in the pressure being sensed by the pressure transducer 12, while the pieces or portions 90 are traveling through the aspiration lumen 18. As graphed in the curve 79 of FIG. 5D, a downward slope 99 and a subsequent steady pressure curve 97 are measured, but as the pieces or portions 90 of thrombus 88 travel down the aspiration lumen 18 of the aspiration catheter 4, a deviation 77 of fluid pressure comprising a plurality of decreases and increases in pressure (increases and decreases in vacuum pressure) is measured. As the pieces or portions 90 of thrombus 88 exit the proximal end of the aspiration lumen 18 of the aspiration catheter 4, a second steady pressure curve 75 is measured. The duration 67 of the deviation 77 is the amount of transit of the particular significant pieces or portions 90 of thrombus 88. The duration 67 can range quite a bit, but in some cases may be less than a second or up to about 30 seconds. When again additional pieces or portions 90 of thrombus 88 are aspirated into and travel down the aspiration lumen 18 of the aspiration catheter 4, another deviation 73 of fluid pressure comprising a plurality of decreases and increases in pressure (increases and decreases in vacuum pressure) is measured. At the end of the curve 79, the vacuum source 6 is shown filling completely with blood 96 and the pieces or portions 90 of thrombus 88, and so an upward slope 95 is measured.

[0036] The measurement device 54, 64 is configured to compare the curve 79 with information stored in the memory module 56, 66 to identify when the pieces or portions 90 of thrombus 88 are actively being aspirated, as in deviation 77 and deviation 73, and when the pieces or portions of thrombus 88 are not being actively, or substantially, aspirated, as in steady pressure curve 97, the steady pressure curve 75, and the steady pressure curve 71. In

some embodiments, the measurement device 54, 64 uses an algorithm to make the comparison. In some embodiments, a pre-set pressure differential ΔP_2 may be stored in the memory module 56, 66 as a threshold, whereby the measurement of a pressure difference 69 less than this threshold does not result in the measurement device 54, 64 commanding the communication device 58a-c, 74 to send a first type of alert via an alert signal 60a-c, 70. In some embodiments, when the pressure difference 69 is greater than (or greater than or equal to) the pre-set pressure differential ΔP_2 , the measurement device 54, 64 then sends a signal to the communication device 58a-c, 74, and the communication device 58a-c, 74 generates an appropriate alert. Communication device 58a, for example a particular color LED, may be illuminated, or an LED may flash in a particular pattern or number of flashes. In some embodiments, the communication device 58a may comprise a light whose intensity increases proportionally with the pressure. Communication device 58b may create a characteristic sound, or may generate an audio message in a number of languages. For example, the audio message may state, "Thrombus being aspirated." In some embodiments, communication device 58b may comprise one or more noises or beeps. In some embodiments, the communication device 58b may comprise a particular series of beeps corresponding to each different condition. For example, three short beeps may correspond to no thrombus being aspirated, while five long, loud beeps may correspond to a system leak. In some embodiments, a plurality of different tones (pitches) may be used to alert a user about different conditions. As an example, a low pitch sound may be used for a first condition (e.g. no thrombus being aspirated) and a second, higher pitch sound may be used for a second condition (e.g. a system leak). In some embodiments, a plurality of different tones may be used to alert a user about a first condition and a second plurality (e.g. in a different combination, or with additional tones) may be used to alert a user about a second condition. Communication device 58c may vibrate or heat in a characteristic pattern, for example, a certain number of repetitions or a certain frequency between repetitions. When the user realizes that the thrombus is being aspirated, the user may choose to advance (or retract) the aspiration catheter 4, for example with fluoroscopic visualization, along the length of the thrombus 88, in an attempt to continue the aspiration of the thrombus 88. In some cases, the user may choose to stop the advancement or retraction of the aspiration catheter 4 at a certain amount of time after the alert is generated, in order to allow the pieces or portions 90 of thrombus 88 to completely exit the aspiration lumen 18. When the measurement device 54, 64 identifies a subsequent steady pressure curve 75, 71 that follows a deviation 77, 73, the measurement device 54, 64 in some embodiments sends a signal that causes the

communication device 58a-c, 74 to generate a second type of alert via an alert signal 60a-c, 70. For example, in some embodiments, communication device 58b may send an audio message that states, “Thrombus no longer being aspirated.” When the user realizes that the thrombus is no longer being aspirated, the user may advance or retract the aspiration catheter, in an attempt to contact another portion of the thrombus 88 that can be aspirated. In some embodiments, the deviation 77 may be positively identified as a true deviation indicating thrombus being actively aspirated, pressure difference 69 is between about 700 pascal and about 1700 pascal. In some embodiments, the deviation 77 may be positively identified as a true deviation indicating thrombus being actively aspirated, pressure difference 69 is between about 1000 pascal and about 1300 pascal. In some embodiments, the deviation 77 may be positively identified as a true deviation indicating thrombus being actively aspirated, pressure difference 69 is about 1138 pascal. The pressure difference 69 may be measured by determining a baseline pressure 63 and a peak pressure 61 and determining the absolute value difference. For example:

$$\text{Absolute value difference (AVD)} = |(-89,631 \text{ pascal}) - (-90,769 \text{ pascal})| = 1138 \text{ pascal}$$

[0037] Or for example:

$$\text{Absolute value difference (AVD)} = |(-43,710 \text{ pascal}) - (-45,102 \text{ pascal})| = 1281 \text{ pascal}$$

[0038] The pressure difference 81 (FIG. 5B) may also represent a deviation that may be identified in a similar manner, after which the communication device 58a-c, 74 generates an appropriate alert, such as, “Clog condition.”

[0039] Because vacuum pressure is a negative pressure, the peak pressure 61, as shown in FIG. 5D, is actually a lower number than the baseline pressure 63. In some embodiments, the measurement device 54, 64 may also be configured to make a comparison, for example by using an algorithm, between a stored differential time t_1 and a duration 65 of a single one of the plurality of decreases and increases in pressure in the deviation 77. For example, in some embodiments, the deviation may be positively identified as a true deviation indicating thrombus being actively aspirated, if the duration is between about 0.001 seconds and about 0.50 seconds. In some embodiments, the deviation may be positively identified as a true deviation indicating thrombus being actively aspirated, if the duration is between about 0.005 seconds and about 0.10 seconds. In some embodiments, the deviation may be

positively identified as a true deviation indicating thrombus being actively aspirated if the duration is between about 0.05 seconds and about 0.20 seconds. In some embodiments, the measurement device 54, 64 is configured to recognize deviation 77 after two or more decreases and increases in pressure are measured. In some embodiments, the measurement device 54, 64 is configured to recognize deviation 77 after five or more decreases and increases in pressure are measured. In some embodiments, the measurement device 54, 64 is configured to recognize deviation 77 after ten or more decreases and increases in pressure are measured.

[0040] Insertion of the pressure transducer 12 in line in either the embodiment of FIG. 2A or the embodiment of FIG. 2B does not measurably change performance characteristics of the aspiration system 2, because the cavity 42 is relatively short and has a relatively large inner diameter, and thus is not a significant source of fluid flow resistance. In some embodiments, the inner diameter may be between about 2.2 mm (0.086 inches) and about 3.2 mm (0.125 inches). In some embodiments, the measurement device 54, 64, 76 need not include a microprocessor, as pre-defined set points (e.g. for certain thresholds) may be included in firmware, microcontroller, or other locations. In some embodiments, including but not limited to the embodiment of FIG. 2B, the pressure transducer 12 may be an off-the-shelf blood pressure monitor system, which is modified or augmented with other components. In some embodiments an off-the-shelf blood pressure monitor system may be used as the output of the aspiration monitoring system 48, 62, 78. In some embodiments, an aspiration catheter 4 may have a pressure transducer in the distal end 16. This pressure transducer may be used as the pressure transducer 12 of the aspiration monitoring system 48, 62, 78. In some embodiments, a pressure sensor may be located within a Tuohy-Borst valve, and introducer sheath, a guiding catheter, or another component of the system through which is in fluid communication with the aspiration lumen 18. In some embodiments, the pressure sensor may be located anywhere within the aspiration lumen of the aspiration catheter.

[0041] In some embodiments, instead of an LED, the visual alert is provided by a communication device 58a comprising a display which displays visual messages of text in a particular language, for example, "Thrombus encountered," "No thrombus encountered," "Clog condition," "System leak," "Loss of vacuum," "Thrombus being aspirated," or "Thrombus no longer being aspirated." The visual messages may be combined with any of the other alert signals 60a-c, 70 described herein. The aspiration monitoring system 48, 62, 78 described herein give real time awareness to users performing aspiration procedures, such as the removal of thrombus via an aspiration system 2. One skilled in the art will recognize that

by knowing the real time condition of the aspiration system 2, the user is able to immediately make changes to the procedure in order to optimize results, increase safety for the patient and/or medical personnel, reduce costs (e.g. number of vacuum sources 6 required), and reduce procedure time (also a cost benefit). Because the user is typically performing multiple tasks during an aspiration procedure, the sensory aid provided by the aspiration monitoring system 48, 62, 78 allows the user to focus on these tasks without having to continually attempt to monitor conditions which are often difficult to visually monitor. The user may also modify and control the aspiration monitoring system 48, 62, 78 via an input 59 (FIG. 2B), which may comprise a data entry module, keyboard, or a series of buttons with a display. The input 59 may in some embodiments comprise an auditory input which accepts voice commands. Alternatively, the user may input information and control the aspiration monitoring system, 48, 62, 78 remotely. Some of the alerts which the user may select or deselect in the aspiration monitoring system 48, 62, 78 include, but are not limited to: whether the aspiration system 2 is potentially blocked or clogged, or is flowing normally; whether thrombus has been contacted or not; whether a clog has occurred; whether the vacuum source 6 is adequate, or whether it has been depleted and requires replacement; whether there is a leak in the aspiration system 2; whether setup or connection of the components of the aspiration system 2 was done correctly or incorrectly; whether to advance the catheter distally; whether to retract the catheter; whether to continue moving the catheter at the same speed; whether to increase or decrease the speed of catheter advancement; whether thrombus is actively being aspirated; and whether thrombus stops being actively aspirated.

[0042] In some embodiments, alternate power sources may be used, for example, standard AC power with or without an AC/DC convertor; direct connection to existing equipment (e.g. vacuum pumps, etc.); solar power. The aspiration monitoring system 48, 62, 78 may be packaged sterile or may be resterilizable by techniques known by those skilled in the art. In some embodiments, flow or volume gauges may be used in conjunction with or instead of the pressure gauge 12, in order to determine, for example, a clog, or a change in the amount of vacuum.

[0043] Though aspiration of thrombus has been described in detail, the aspiration monitoring system 48, 62, 78 has utility in any aspiration application wherein heterogeneous media is being aspirated. This may include the aspiration of emboli (including not thrombotic emboli) from ducts, vessels, or cavities of the body, or even from solid or semi-solid portions of the body, including, but not limited to, portions of fat, breasts, and cancerous tissue.

[0044] In some embodiments, the aspiration system 2 is be provided to the user as a kit with all or several of the components described, while in other embodiments, only the aspiration monitoring system 48 is provided. Though discussion herein includes embodiments for aspiration of thrombus and blood, the definition of the word “fluid” should be understood throughout to comprise liquids and gases.

[0045] In some embodiments, an additional or alternate sensor may be used to monitor flow conditions for the notification of the user, including, but not limited to: a Doppler sensor, an infrared sensor, or a laser flow detection device. In some embodiments, an externally-attached Doppler sensor may be employed. In some embodiments, an infrared sensor or a laser flow detection device may be employed around the extension tubing 10.

CLAIMS:

1. A system for real time monitoring of catheter aspiration, comprising:
 - a housing having a first port adapted for detachable connection to a vacuum source and a second port adapted for detachable connection with an aspiration catheter, the housing having an interior configured for liquid to pass therethrough;
 - a pressure sensor in fluid communication with the interior of the housing;
 - a measurement device coupled to the pressure sensor and configured for measuring deviations in fluid pressure; and
 - a communication device coupled to the measurement device and configured to generate an alert signal when a deviation in fluid pressure measured by the measurement device exceeds a pre-set threshold.
2. The system of claim 1, wherein the communication device is configured to generate a first type of alert in response to a deviation measured by the measurement device comprising a plurality of increases and decreases of vacuum pressure.
3. The system of claim 2, wherein the plurality of increases and decreases of vacuum pressure comprises a baseline vacuum pressure and a peak vacuum pressure, and wherein the pre-set threshold is the difference between the peak vacuum pressure and the baseline vacuum pressure.
4. The system of claim 3, wherein the pre-set threshold is between about 700 pascal and about 1700 pascal.
5. The system of claim 4, wherein the pre-set threshold is between about 1000 pascal and about 1300 pascal.
6. The system of claim 5, wherein the pre-set threshold is about 1158 pascal.
7. The system of claim 1, further comprising a memory module, wherein the measurement device is configured to compare measured deviations in pressure with information contained in the memory module.

8. The system of claim 7, wherein the measurement device comprises a microprocessor.
9. The system of claim 1, wherein the first port comprises a female luer connector and the second port comprises a male luer connector.
10. The system of claim 1 further comprising:
 - a vacuum source for coupling to the first port; and
 - an aspiration catheter having an aspiration lumen for coupling to the second port.
11. The system of claim 10, wherein the communication device is configured to generate a first type of alert in response to a deviation measured by the measurement device comprising a plurality of increases and decreases of vacuum pressure.
12. The system of claim 11, wherein the plurality of increases and decreases of vacuum pressure comprises a baseline vacuum pressure and a peak vacuum pressure, and wherein the pre-set threshold is the difference between the peak vacuum pressure and the baseline vacuum pressure.
13. The system of claim 12, wherein the pre-set threshold is between about 700 pascal and about 1700 pascal.
14. The system of claim 10, wherein the alert signal is provided by at least one of an LED, a piezoelectric device, or a vibration device.
15. The system of claim 11, wherein the first type of alert comprises at least one of an audible alert, a visible alert, and a tactile alert.
16. The system of claim 1, wherein the alert signal is provided by at least one of an LED, a piezoelectric device, or a vibration device.
17. The system of claim 1, wherein the interior of the housing is configured for blood to pass therethrough.
18. The system of claim 2, wherein the first type of alert comprises at least one of an audible alert, a visible alert, and a tactile alert.

19. The system of claim 2, wherein the plurality of increases and decreases of vacuum pressure corresponds to one or more portions of thrombus being aspirated through an aspiration lumen of an aspiration catheter connected to the second port.

20. The system of claim 2, wherein the communication device is configured to generate a second type of alert in response to the deviation comprising a plurality of increases and decreases of vacuum pressure no longer being measured by the measurement device.

21. The system of claim 1, wherein the pressure sensor is configured to measure a negative pressure.

22. A self-contained monitoring device for real time monitoring of catheter aspiration, configured for connection in between an aspiration catheter and a vacuum source, comprising:

a housing having a first port adapted for connection to a vacuum source and a second port adapted for connection to an aspiration catheter, the housing having an interior configured for liquid to pass therethrough;

a pressure sensor in fluid communication with the interior of the housing, the pressure sensor configured to measure negative pressure;

a measurement device coupled to the pressure sensor and configured for measuring deviations in negative fluid pressure; and

a communication device coupled to the measurement device and configured to generate an alert signal when a deviation in fluid pressure measured by the measurement device exceeds a pre-set threshold.

23. The self-contained monitoring device of claim 22, wherein the communication device is configured to generate a first type of alert in response to a deviation measured by the measurement device comprising an increase and decrease of vacuum pressure.

24. The self-contained monitoring device of claim 23, wherein the increase and decrease of vacuum pressure comprises a baseline vacuum pressure and a peak vacuum pressure, and wherein the pre-set threshold is compared to a difference between the peak vacuum pressure and the baseline vacuum pressure.

25. The self-contained monitoring device of claim 24, wherein the pre-set threshold is between about 700 pascal and about 1700 pascal.

26. The self-contained monitoring device of claim 25, wherein the pre-set threshold is between about 1000 pascal and about 1300 pascal.

27. The self-contained monitoring device of either one of claims 23 or 24, wherein the first type of alert comprises at least one of an audible alert, a visible alert, and a tactile alert.

28. The self-contained monitoring device of either one of claims 23 or 24, wherein the increase and decrease of vacuum pressure corresponds to one or more portions of thrombus being aspirated through an aspiration lumen of an aspiration catheter connected to the second port.

29. The self-contained monitoring device of either one of claims 23 or 24, wherein the communication device is configured to generate a second type of alert in response to the deviation comprising an increase and decrease of vacuum pressure no longer being measured by the measurement device.

30. The self-contained monitoring device of any one of claims 22-24, further comprising a memory module, wherein the measurement device is configured to compare measured deviations in pressure with information contained in the memory module.

31. The self-contained monitoring device of any one of claims 22-24, wherein the measurement device comprises a microprocessor.

32. An aspiration system comprising the self-contained monitoring device of any one of claims 22-24, and further comprising:

a vacuum source for coupling to the first port; and

an aspiration catheter having an aspiration lumen for coupling to the second port.

33. The self-contained monitoring device of any one of claims 22-24, wherein the alert signal is provided by at least one of an LED, a piezoelectric device, or a vibration device.

34. The self-contained monitoring device of any one of claims 22-24, wherein the alert signal is configured to indicate a clogged condition.

35. The self-contained monitoring device of any one of claims 22-24, wherein the alert signal is configured to indicate a system leak.

36. The self-contained monitoring device of any one of claims 22-24, wherein the alert signal is configured to indicate whether thrombus is being aspirated.

37. The self-contained monitoring device of any one of claims 22-24, wherein the interior of the housing is configured for body fluids to pass therethrough.

38. The self-contained monitoring device of claim 37, wherein the interior of the housing is configured for blood to pass therethrough.

39. The self-contained monitoring device of any one of claims 22-31 or 33-38, wherein the first port is adapted for detachable connection to the vacuum source.

40. The self-contained monitoring device of any one of claims 22-31 or 33-39, wherein the second port is adapted for detachable connection to the aspiration catheter.

41. The self-contained monitoring device of claim 22, wherein the pressure sensor is within the interior of the housing.

42. The self-contained monitoring device of claim 41, wherein the pressure sensor is configured to measure liquid pressure within the interior of the housing.

43. The self-contained monitoring device of claim 22, wherein the pressure sensor is configured for highest accuracy and/or precision within the range of pressures between about 0 pascal and about -101,325 pascal.

44. A system for real time monitoring of catheter aspiration, comprising:

an aspiration catheter having a proximal end, a distal end, and an aspiration lumen extending therebetween, the distal end of the aspiration catheter configured for placement within the vasculature of a subject; and

a monitoring device comprising:

a first sensor configured to be carried on the aspiration catheter, and further configured to monitor a flow condition related to flow through the aspiration lumen of the aspiration catheter, the first sensor configured to measure negative pressure;

a measurement device coupled to the first sensor and configured for measuring deviations output by the first sensor; and

a communication device coupled to the measurement device and configured to generate a first alert when a deviation measured by the measurement device exceeds a pre-set threshold, the first alert indicative of the aspiration status of the system.

45. The system of claim 44, wherein the first alert is indicative of active aspiration.

46. The system of claim 45, wherein the communication device is configured to generate a second alert, and wherein the second alert is indicative of non-active aspiration.

47. The system of claim 44, wherein the first alert is indicative of non-active aspiration.

48. The system of claim 47, wherein the communication device is configured to generate a second alert, and wherein the second alert is indicative of active aspiration.

49. The system of claim 44, wherein the monitoring device further comprises a housing having a first port configured to be hydraulically coupled to a vacuum source, a second port configured to be hydraulically coupled to the aspiration lumen of the aspiration catheter, and a cavity extending between the first port and the second port, the cavity configured for aspirated blood to pass therethrough, wherein the first sensor is disposed within the cavity.

50. The system of claim 44, wherein the first sensor is configured for highest accuracy and/or precision within the range of pressures between about 0 pascal and about -101,325 pascal.

51. The system of claim 44, further comprising a second sensor configured to be carried on the aspiration catheter, and further configured to monitor a flow condition related to flow through the aspiration lumen of the aspiration catheter, the second sensor comprising a flow sensor.

52. The system of claim 51, wherein the flow sensor comprises a Doppler sensor.

53. The system of claim 51, wherein the flow sensor comprises an infrared sensor.
54. The system of claim 51, wherein the flow sensor comprises a laser.
55. The system of claim 44, wherein the first alert is indicative of active aspiration of a thrombus.
56. The system of claim 44, wherein the first alert comprises at least one of an audible alert, a visible alert, and a tactile alert.
57. The system of claim 44, wherein the measurement device comprises a microprocessor.
58. The system of claim 44, wherein the monitoring device further comprises a memory, and wherein the measurement device is configured to compare measured deviations output by the first sensor with information contained in the memory.
59. The system of claim 58, wherein a positively identified measured deviation has a duration of between about 0.001 seconds and about 0.50 seconds.
60. The system of claim 58, wherein a positively identified measured deviation comprises a pressure difference of between about 700 pascal and about 1700 pascal.
61. A monitoring device for real time monitoring of catheter aspiration, comprising:
- a housing having a first port adapted for connection to a vacuum source;
 - a pressure sensor in fluid communication with an interior of the housing;
 - a measurement device coupled to the pressure sensor and configured for measuring deviations in fluid pressure; and
 - a communication device coupled to the measurement device and configured to generate an alert signal when a deviation in fluid pressure measured by the measurement device exceeds a pre-set threshold, wherein the communication device is configured to generate a first type of alert in response to a deviation measured by the measurement device comprising an increase and decrease of vacuum pressure, wherein the increase and decrease of vacuum pressure comprises a baseline

vacuum pressure and a peak vacuum pressure, and wherein the pre-set threshold is compared to a difference between the peak vacuum pressure and the baseline vacuum pressure.

62. The monitoring device of claim 61, wherein the pre-set threshold is between about 700 pascal and about 1700 pascal.

63. The monitoring device of claim 62, wherein the pre-set threshold is between about 1000 pascal and about 1300 pascal.

64. The monitoring device of claim 61, further comprising a memory module, wherein the measurement device is configured to compare measured deviations in pressure with information contained in the memory module.

65. The monitoring device of claim 61, wherein the measurement device comprises a microprocessor.

66. The monitoring device of claim 61, wherein the first port comprises a female luer connector.

67. The monitoring device of claim 61, wherein the alert signal is provided by at least one of an LED, a piezoelectric device, or a vibration device.

68. The monitoring device of claim 61, wherein the fluid pressure comprises a fluid pressure of blood being aspirated from a patient.

69. The monitoring device of claim 61, wherein the first type of alert comprises at least one of an audible alert, a visible alert, and a tactile alert.

70. The monitoring device of claim 61, wherein the increase and decrease of vacuum pressure corresponds to one or more portions of thrombus being aspirated through an aspiration lumen of an aspiration catheter connected to a second port of the housing.

71. The monitoring device of claim 61, wherein the communication device is configured to generate a second type of alert in response to the deviation comprising an increase and decrease of vacuum pressure no longer being measured by the measurement device.

72. The monitoring device of claim 61, wherein the alert signal is configured to indicate a clogged condition.

73. The monitoring device of claim 61, wherein the alert signal is configured to indicate a system leak.

74. The monitoring device of claim 61, wherein the alert signal is configured to indicate thrombus being aspirated.

75. The monitoring device of claim 61, wherein the alert signal is configured to indicate thrombus no longer being aspirated.

76. The monitoring device of claim 61, wherein the alert signal is configured to indicate at least two of the states selected from the group consisting of a clogged condition, a system leak, thrombus being aspirated, and thrombus no longer being aspirated.

77. The monitoring device of claim 61, wherein the pressure sensor is disposed within the interior of the housing.

78. The monitoring device of claim 77, wherein the pressure sensor is configured to measure liquid pressure within the interior of the housing.

79. The monitoring device of claim 61, further comprising an aspiration catheter having an aspiration lumen configured to be placed in fluid communication with the interior of the housing, wherein the pressure sensor is disposed within the aspiration lumen of the aspiration catheter.

80. The monitoring device of claim 61, wherein the pressure sensor is configured to measure a negative pressure.

81. The monitoring device of claim 61, wherein the interior of the housing is configured for blood to pass therethrough.

82. A monitoring device for real time monitoring of catheter aspiration, comprising:
a housing having a first port adapted for connection to a vacuum source, the housing having an interior configured for liquid to pass therethrough;
a pressure sensor disposed within the interior of the housing, the pressure sensor configured to measure negative pressure;

a measurement device coupled to the pressure sensor and configured for measuring deviations in negative fluid pressure; and

a communication device coupled to the measurement device and configured to generate an alert signal when a deviation in fluid pressure measured by the measurement device exceeds a pre-set threshold.

83. The monitoring device of claim 82, wherein the pre-set threshold is between about 700 pascal and about 1700 pascal.

84. The monitoring device of claim 83, wherein the pre-set threshold is between about 1000 pascal and about 1300 pascal.

85. The monitoring device of claim 82, further comprising a memory module, wherein the measurement device is configured to compare measured deviations in pressure with information contained in the memory module.

86. The monitoring device of claim 82, wherein the measurement device comprises a microprocessor.

87. The monitoring device of claim 82, wherein the first port comprises a female luer connector.

88. The monitoring device of claim 82, wherein the alert signal is provided by at least one of an LED, a piezoelectric device, or a vibration device.

89. The monitoring device of claim 82, wherein the fluid pressure comprises a fluid pressure of blood being aspirated from a patient.

90. The monitoring device of claim 82, wherein the alert signal is configured to indicate a clogged condition.

91. The monitoring device of claim 82, wherein the alert signal is configured to indicate a system leak.

92. The monitoring device of claim 82, wherein the alert signal is configured to indicate thrombus being aspirated.

93. The monitoring device of claim 82, wherein the alert signal is configured to indicate thrombus no longer being aspirated.

94. The monitoring device of claim 82, wherein the alert signal is configured to indicate at least two of the states selected from the group consisting of a clogged condition, a system leak, thrombus being aspirated, and thrombus no longer being aspirated.

95. The monitoring device of claim 82, further comprising an aspiration catheter having an aspiration lumen in fluid communication with the interior of the housing.

96. The monitoring device of claim 82, wherein the pressure sensor is configured to measure liquid pressure within the interior of the housing.

97. The monitoring device of claim 82, wherein the interior of the housing is configured for blood to pass therethrough.

98. A monitoring device for real time monitoring of catheter aspiration, comprising:
a housing having a first port adapted for connection to a vacuum source;
a pressure sensor disposed within an interior of the housing;
a measurement device coupled to the pressure sensor and configured for measuring deviations in fluid pressure; and

a communication device coupled to the measurement device and configured to generate an alert signal when a deviation in fluid pressure measured by the measurement device exceeds a pre-set threshold, wherein the communication device is configured to generate a first type of alert in response to a deviation measured by the measurement device comprising an increase and decrease of vacuum pressure, wherein the increase and decrease of vacuum pressure comprises a baseline vacuum pressure and a peak vacuum pressure, and wherein the pre-set threshold is compared to a difference between the peak vacuum pressure and the baseline vacuum pressure.

99. The monitoring device of claim 98, wherein the first type of alert comprises at least one of an audible alert, a visible alert, and a tactile alert.

100. The monitoring device of claim 98, wherein the increase and decrease of vacuum pressure corresponds to one or more portions of thrombus being aspirated through an aspiration lumen of an aspiration catheter connected to a second port of the housing.

101. The monitoring device of claim 98, wherein the communication device is configured to generate a second type of alert in response to the deviation comprising an increase and decrease of vacuum pressure no longer being measured by the measurement device.

102. The monitoring device of claim 98, wherein the pressure sensor is configured to measure liquid pressure within the interior of the housing.

103. The monitoring device of claim 98, wherein the pressure sensor is configured to measure a negative pressure.

104. The monitoring device of claim 98, wherein the interior of the housing is configured for blood to pass therethrough.

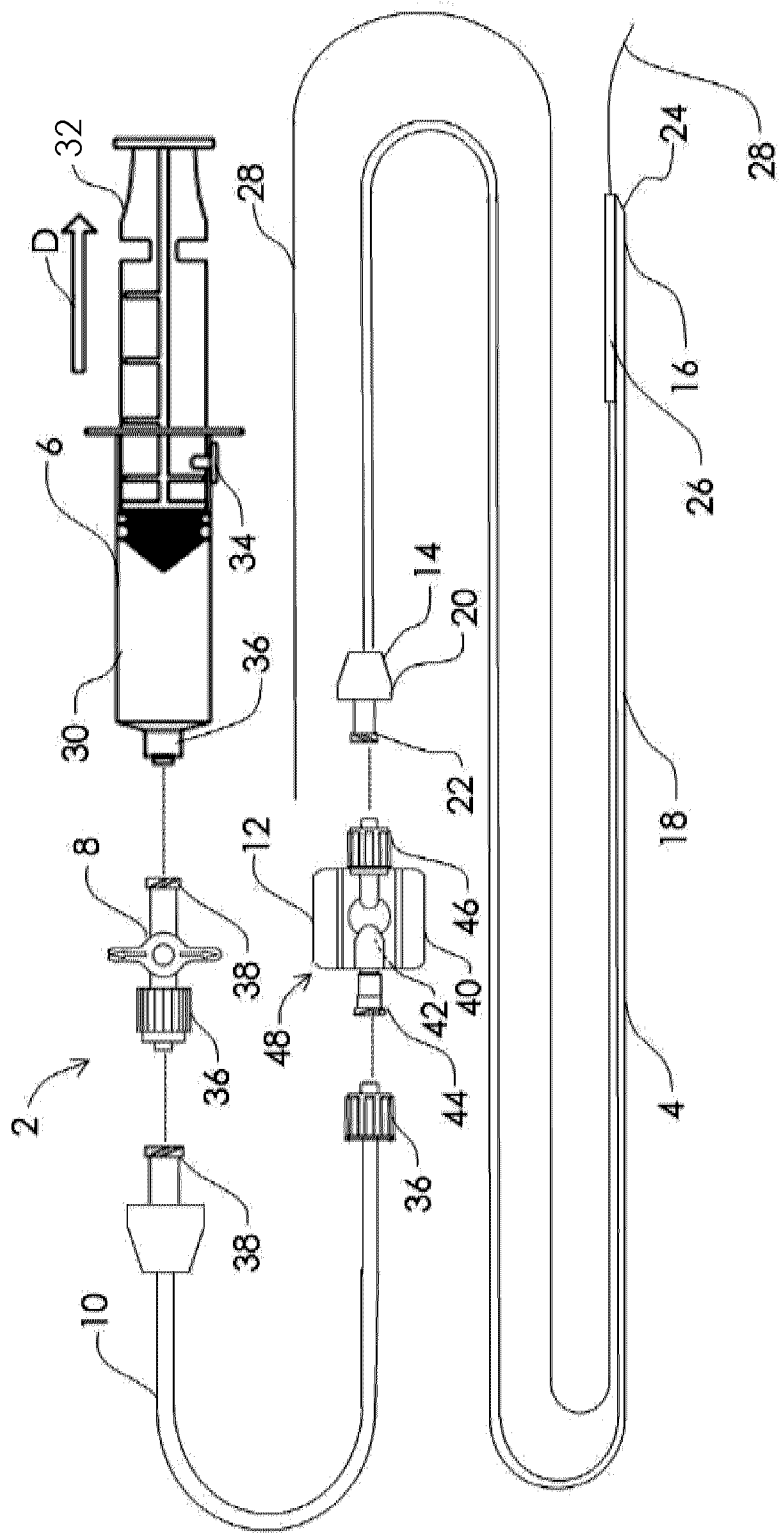

FIG. 1

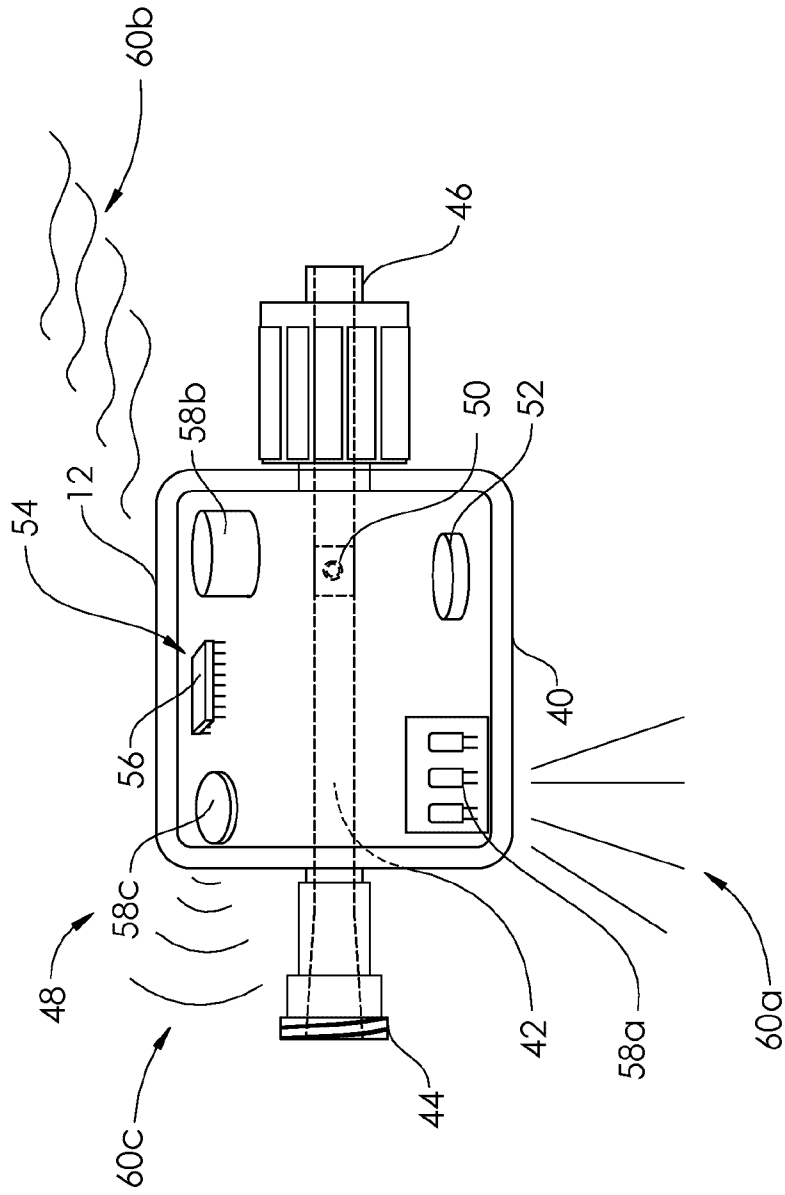
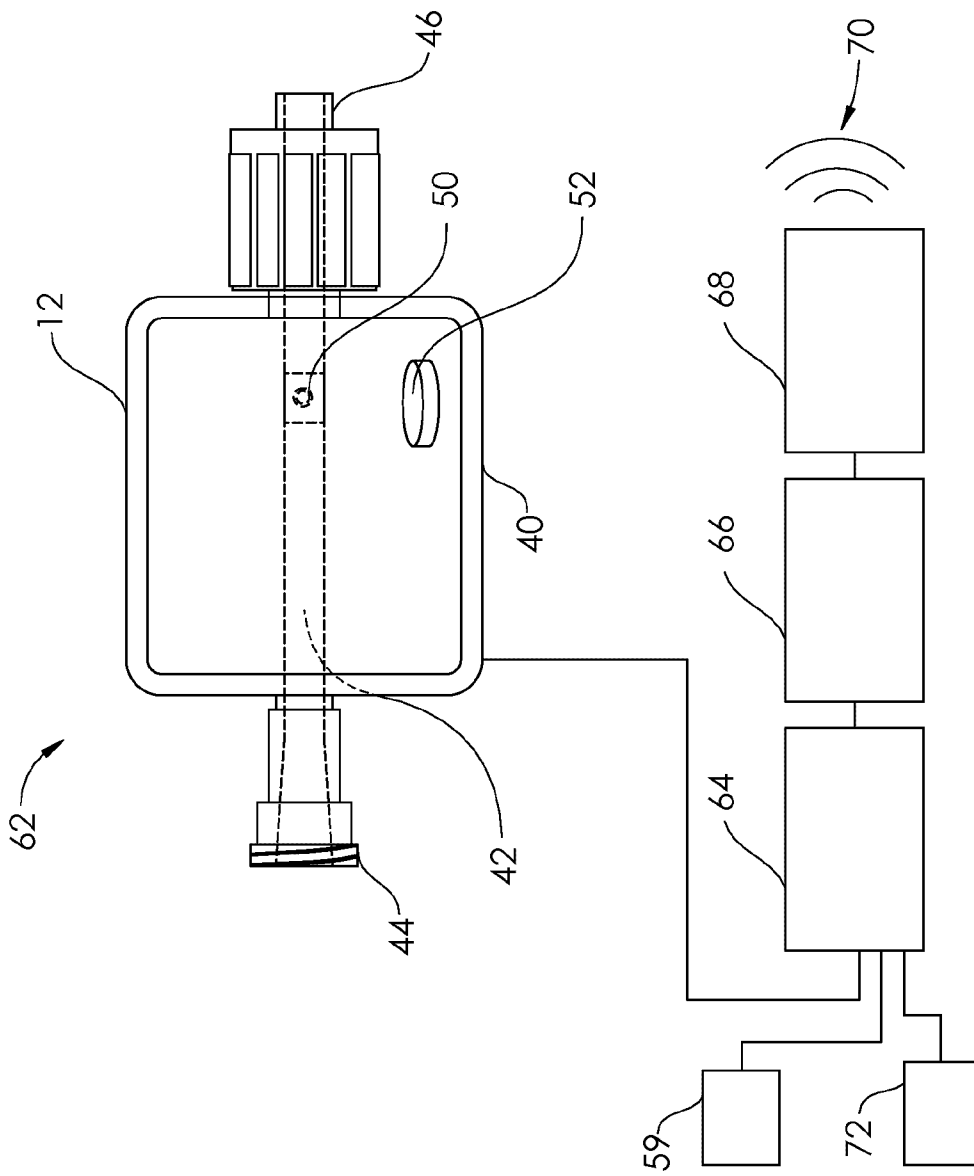

FIG. 2A



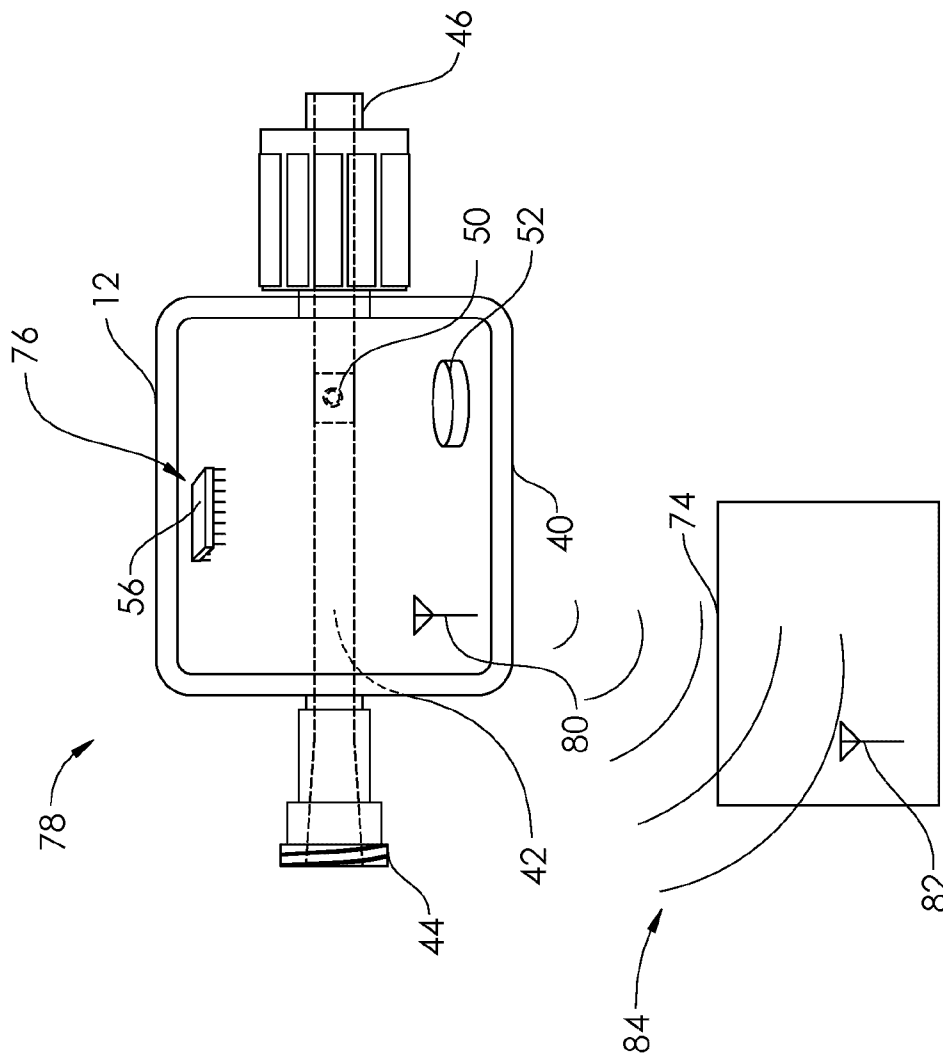

FIG. 3

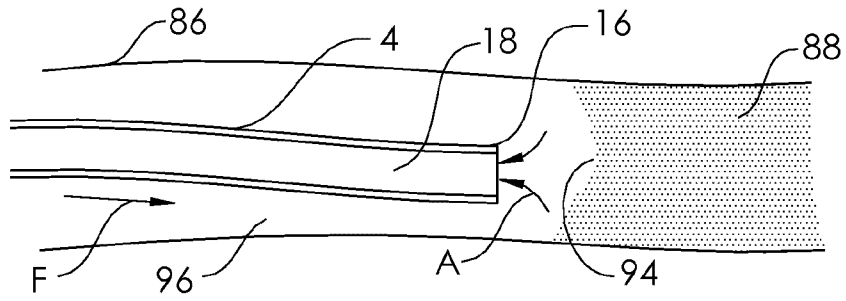

FIG. 4A

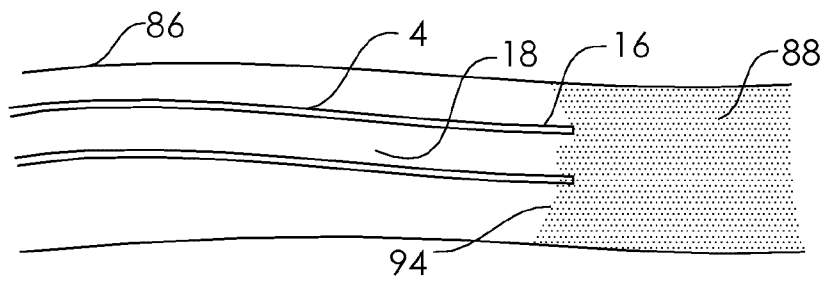

FIG. 4B

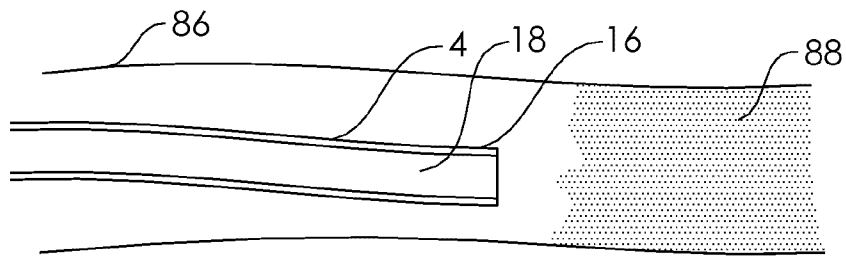

FIG. 4C

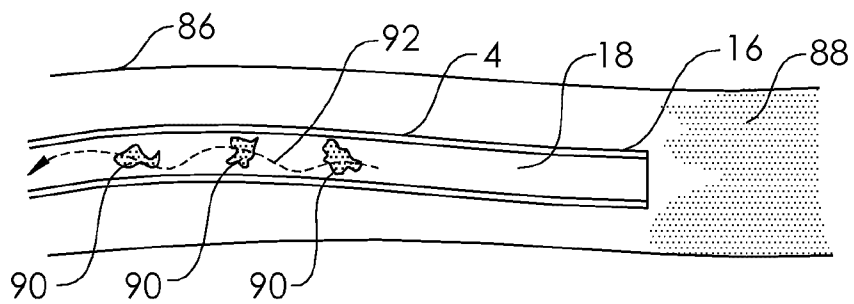

FIG. 4D

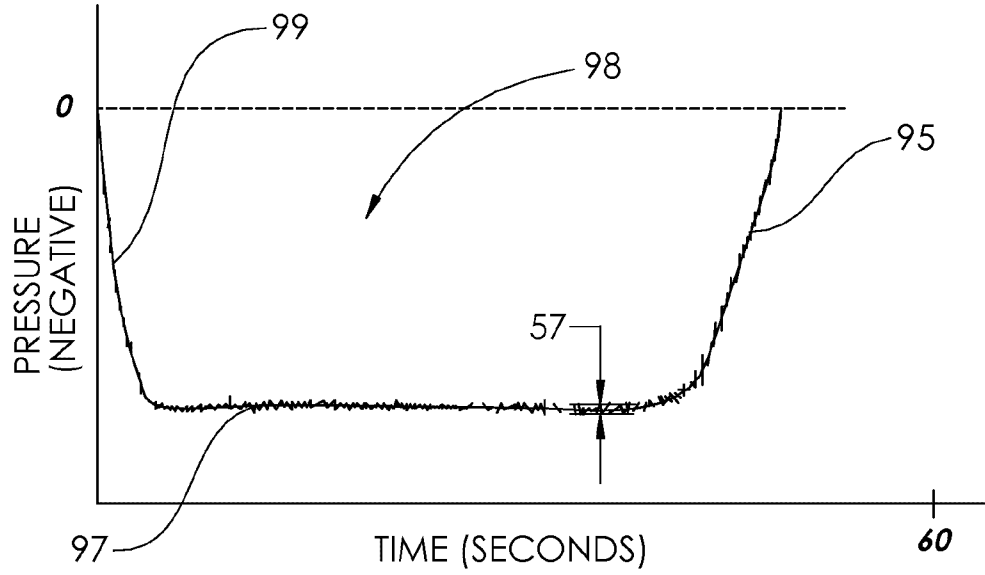

FIG. 5A

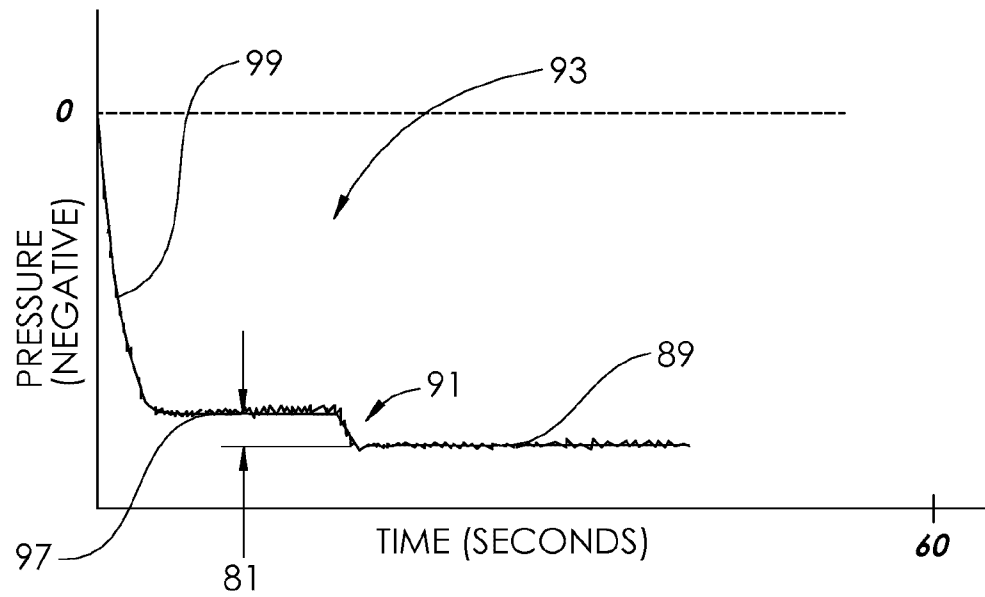

FIG. 5B

