



US 20020109777A1

(19) **United States**

(12) **Patent Application Publication**  
**Huang et al.**

(10) **Pub. No.: US 2002/0109777 A1**

(43) **Pub. Date: Aug. 15, 2002**

(54) **FILM SCANNING DEVICE (1)**

(52) **U.S. Cl. .... 348/96; 355/81**

(76) Inventors: **Pony Huang, Taipei City (TW); Kevin Tseng, Hsin Chu City (TW)**

(57) **ABSTRACT**

Correspondence Address:  
**NATH & ASSOCIATES**  
**1030 15th STREET**  
**6TH FLOOR**  
**WASHINGTON, DC 20005 (US)**

To delete the unnecessary work, the same CCD light sensor is used for pictures of stripfilm and slid mount.

A film scanning device that includes:

(21) Appl. No.: **09/938,836**

the first opening was located at the body which for inserting the developed strip film;

(22) Filed: **Aug. 27, 2001**

the second opening was located at the body which is an exit for the strip film which was inserted into the first opening;

(30) **Foreign Application Priority Data**

the third opening was located in front of the body which is for inserting and pulling out the slide mount following the direction vertical to the direction which the strip film was moved; and

Aug. 28, 2000	(TW).....	89117417
Aug. 28, 2000	(TW).....	89117418
Aug. 28, 2000	(TW).....	89117419
Aug. 28, 2000	(TW).....	89117420
Aug. 28, 2000	(TW).....	89117421

a photographic sensor which took the pictures of the strip film was inserted from the first opening and/or the slide mount was inserted from the third opening; and

**Publication Classification**

a projecting light which was used to project the pictures from the photographic sensor.

(51) **Int. Cl.<sup>7</sup> ..... G03B 27/80**

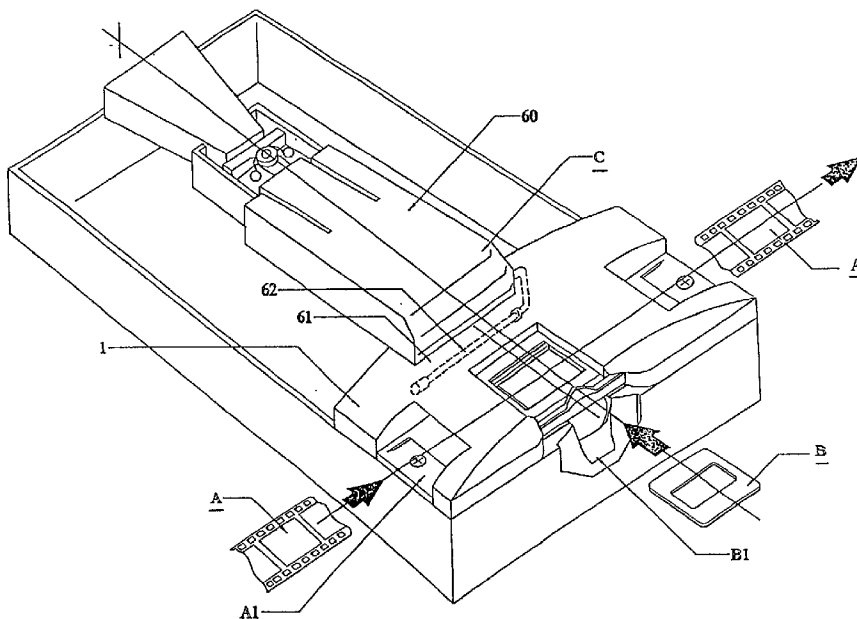

【 図 1 】

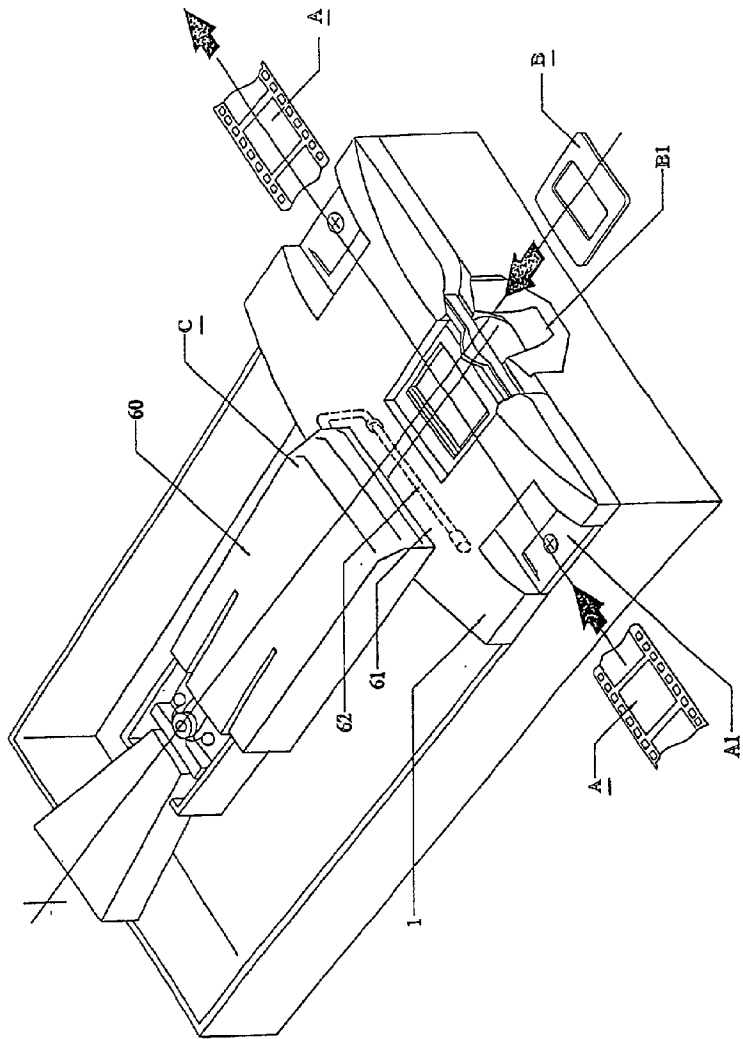

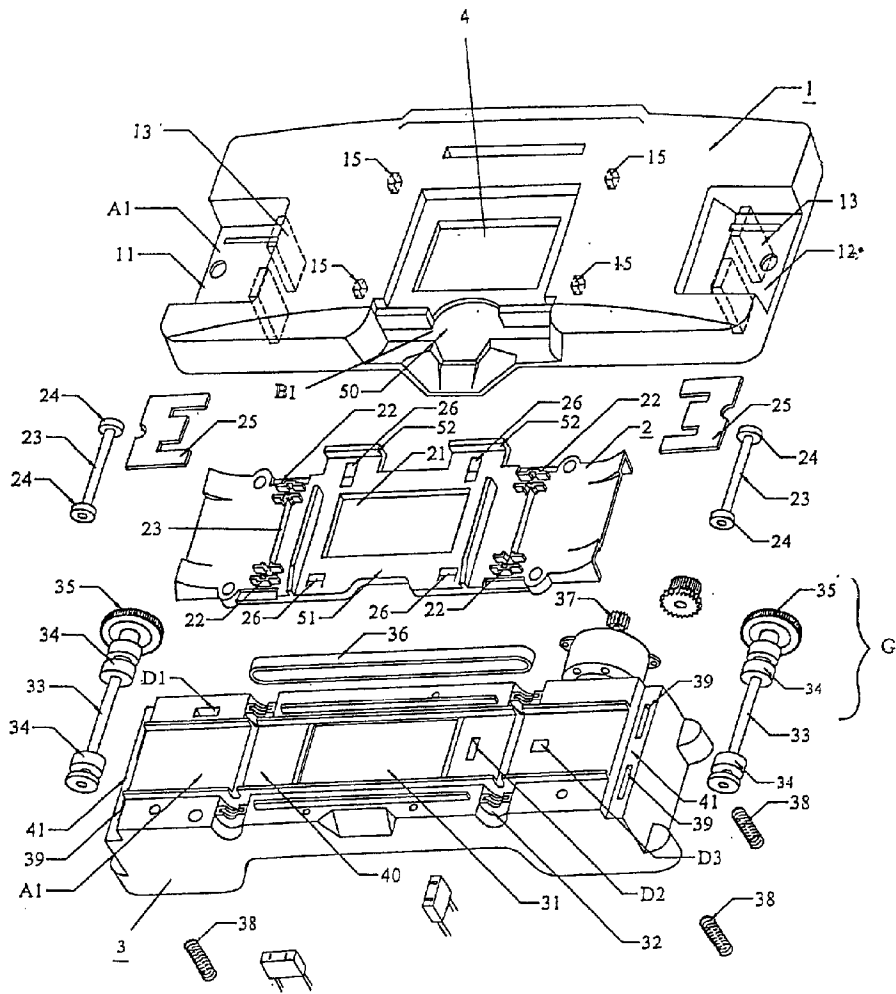

【图 2】

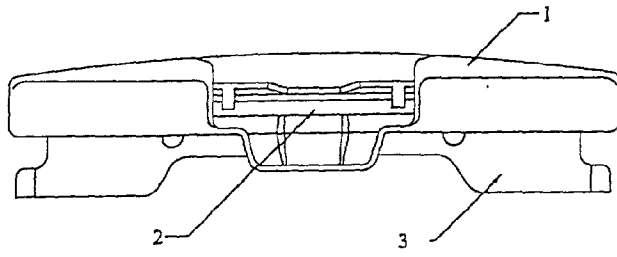

【図 3】

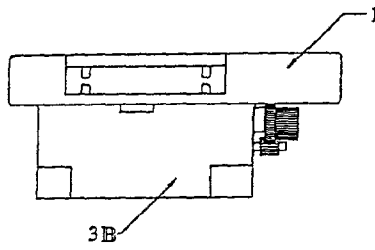

【図 4】

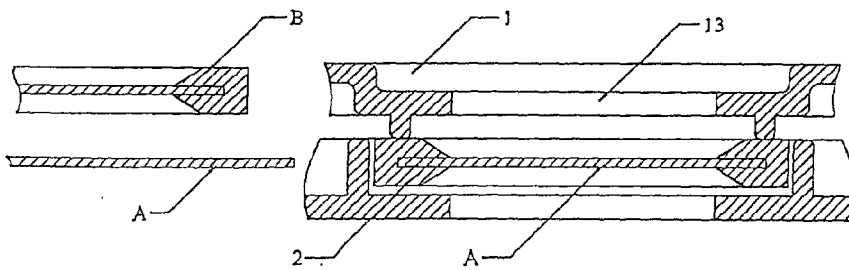

【図 5】

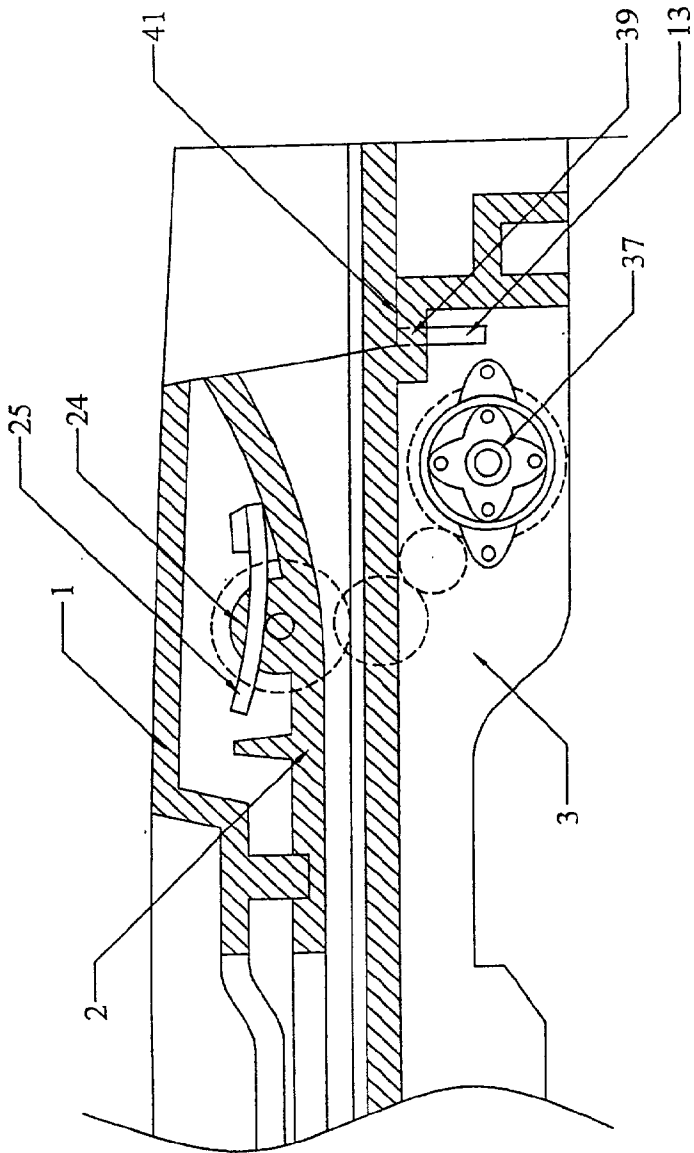

【図6】

**FILM SCANNING DEVICE (1)****BACKGROUND OF THE INVENTION****[0001]** 1. Technical Field of the Invention

**[0002]** The present invention relates to a film scanning device which uses the same lighting device for strip film and slide mount.

**[0003]** 2. Description of Related Art**[0004]** Prior Technique

**[0005]** A scanner is used to scan the pictures of strip film is concerning the light which read and injected to the film thereafter. The projective light from the photo picture project to the strip film was converted to an image by an image lens and the picture image was read, then the image was treated by relevant necessary corresponding procedures, then the picture data (image data signal) was sent to the picture operating device.

**[0006]** Such a detail scanning device in the publication Number 224688 has been shown in the publication Number 224688 which was published in the Kokai Patent gazette which published in 1999.

**[0007]** A slide mount was inserted through the vertical direction of the moving direction the strip film was moved, the first guide combined to the main body at the inserting position of slide mount was inserted from the third opening at the aforesaid main body, the second guide which located at the inserting position of the strip film to set up the slid mount between it and the first guide.

**[0008]** A carrying actuator which was used to move the strip film automatically not only having the carrying function, furthermore, the carrying mechanism was assembled to combine with second guide, also the first guide which located between the light path of picture from strip film or slide mount to the photographic sensor.

**[0009]** The advantages of the prior invention are of the possibilities of the film strip and slide mount, in which the pictures were taken by the same CCD light sensor when the film actuating mechanism. It can be moved by a mount carrier which the plural slide mount and film strip are actuated by the same roller through the up and down movable bar.

**[0010]** However, the complicate operation must be very careful because the components disclosed in the aforesaid prior invention which the slide mount must be filled into the mount carrier when the pictures of slide mount are scanning.

**THE OBJECTS OF THIS INVENTION**

**[0011]** In view of the foregoing and other known disadvantages of the prior art, the object of present invention is to find the solution to resolve the disadvantages which including complicate operation need for the conduction let it became possible to use the same CCD light sensor for both strip film and light mount.

**[0012]** The Technique Used to Achieve the Purposes

**[0013]** The feature of present invention is shown in claim 1, a film scanning device that includes:

**[0014]** the first opening was located at the body which for inserting the developed strip film;

**[0015]** the second opening was located at the body which is an exit for the strip film which was inserted into the first opening;

**[0016]** the third opening was located in front of the body which is for inserting and pulling out the slide mount following the direction vertical to the direction which the strip film was moved; and

**[0017]** a photographic sensor which took the pictures of the strip film was inserted from the first opening and/or the slide mount was inserted from the third opening; and

**[0018]** a projecting light which was used to project the pictures from the photographic sensor. Therefore, the strip film are inserted from the first opening under the same status and it is not necessary to fill any special carrier inside it. It is not need any carrier which special necessary for the prior art after scanning. Otherwise, the slide mount is inserted from the third opening and not necessary to fill any special carrier inside it with the same reason as aforesaid.

**[0019]** The another feature of present invention is shown as claim 2, which a film scanning device that includes:

**[0020]** The first opening was located at the body which for inserting the developed strip film; the second opening was located at the body which is an exit for the strip film which was inserted into the first opening; the third opening was located in front of the body which is for inserting and pulling out the slide mount following the direction vertical to the direction which the strip film was moved; a photographic sensor which took the pictures of the strip film was inserted from the first opening and/or the slid mount was inserted from the third opening; a projecting light which was used to project the pictures from the photographic sensor.

**[0021]** Based on the constructs as above-mentioned, between the first guide located at the body and the inserted position that the slid mount, the second guide was set up, therefore, the components of strip film and slide mount are simplified. The same photographic sensor can be used for the scanning in either side.

**[0022]** 1. The further feature of present invention is shown as claim 3, in which the film scanning film further including: an carrying actuator which was used to move the strip film automatically having the carrying function; the first guide which located between the light path of picture from strip film or slide mount to the photographic sensor.

**[0023]** Otherwise, the second guide is assembled to the body at the movable side of carry mechanism of strip film and unified into one body. Also, because the first guide which located between the light path of picture from strip film or slide mount to the photographic sensor, and the first guide is fixed material, the distance between the scanner having photographic sensor and film is getting small, the object of minimizing the volume of the scanner is achieved.

**[0024]** The term, strip film is used in the text is same as the strip film used in usual. Usually, the strip film is positive film, however, the negative film in the text of present invention is either available in the examples in it. The strip film are used in the examples in present invention.

DETAIL DESCRIPTION OF THE  
EMBODIMENTS

EXAMPLES

[0025] The example first showed the whole device in the drawings, positive and negative films are included in strip film (A), slide mount is shown in mount (B), both of them are readable by the same light device. It is very easy to distinguish the carrying mechanism (A1) which include carrying actuator of strip film (A), inserting system (B1) of slide mount (B), and scanning system (C).

[0026] The carrying actuator of carrying mechanism (A1) having a body which is composed of three layers, cover (1) is of an always horizon plate, pressed plate (2), and a supporter (3).

[0027] In two sides of the cover (1) The strip film (A) is moved through the first opening (11) in its long side direction, the first light path (4) will be mentioned later is transited through light source and formed by around the central portion of the second opening (12).

[0028] The length of light path (4) is equal to the sum of strip film (A) and slide mount (B), the width of strip film (a) is the difference the perforation subtracted the width, is about the same the width of slide mount (B) is the difference of bar subtracted the width.

[0029] Furthermore, the length of cover (1) is from the entrance of the first opening (11) to the second opening, it is desirable 8 coma length of the strip film (A). However, it is not restricted at this length, means any proper length is available.

[0030] A press plate (2) is beneath adapting to the cover (1), it was made of thin resin plate, and the above-mentioned first light (4) is located at its central portion in accordance with the size of the second light path (21).

[0031] The both sides of the second light path (21) having one pair of shaft basis (22) which in the width direction of press plate (2). In order to support the two sides of shaft (23), the length of said shaft basis (22) is about the width of press plate (2).

[0032] The idling rollers (24) were embedded in the two sides of shaft (23), and a light lug is downward and beneath the press plate (2).

[0033] Although strip film (A) is carried from the first opening (11) of the cover (1) to inside the press plate (2), the idling rollers (24) are connected to the upper part of the strip film (A).

[0034] One end of (25) in drawings is pressed downward to the middle part of the shaft (23), and the other end is fixed by a plate-form-spring to the proper position of the press plate (2).

[0035] There are four outward fossas (26) located at the second light path (21) on the surface of press plate (2). The lugs (15) are lugged from the bottom of the cover (1) in accordance with the fossas (26) on each corresponding position of fossas (26), the relevant position in every direction, front, rear, left and right side are usually maintained constantly.

[0036] The bottom of the press plate (2) is contacted and fixed to supporting plate (3), and the central portion of supporting plate (3) having the first light (4) of cover (1) and the third light path (31) which the size in accordance with the second light path (21).

[0037] The same matter with the shaft basis (22) of the press plate (2) are right bottom of the third light path (31) are name shaft basis (32), the actuating rollers (34) are embedded to shafts (33) at two sides of the third light path (31). Therefore, the idling rollers (24) of the press plate (2) are corresponding a up-down relation to the rollers (34).

[0038] The rear part of a pair of shafts (33) are slightly lugged outward from the rear part of the supporting plate (3), the carrying part (35) are corresponding to each lug, and said carrying parts are of timing belt (36). One side of the pair of shaft (33) connected to the motor (37) which located at the reduced gear which located at the proper position of the supporting plate (3). Accordingly, the rotating force is transmitted to the actuating roller (34) between the timing belt (36) and shaft (33). This is the carrying mechanism (G) having actuator in the present example.

[0039] Otherwise, the spring (38) are fixed with the end way coil springs which located at the four corners of the supporting plate (3). The springs (38) are fixed by the devices that are not shown in the drawings.

[0040] Parts (39) are located on the two ends of the supporting plate (3), tab hole are located at its front and back sides. Two inside ends of the cover (1) in this example, equivalent to the pair lug balances (13) downward and lugged from the inside of the second opening (12) and the first opening, that is able to maintain good relation between cover (1) and supporting plate (3).

[0041] The central line inside the supporting plate (3) are constantly directed to the long hand direction, the width of strip film (A) and the second guide (40) of the strip film are about the same and lightly passed through it, and two end cutting are formed in two sides of the second guide (40).

[0042] When press plate (2) is fixed by the cover (1), and together with the supporting plate (3), the first opening (11) of the cover (1) and the inside part of the second opening (12), the first opening (11) and the inside in bottom of the second opening (12) are at the same horizon plate with the second guide (40).

[0043] D1 in FIG. 2 are used to recognize the exist of the strip film (A), through the sensor to determined the position of the strip film. The layout of the aforesaid sensor in present example, in which the insertion of strip film (A) is detected by the sensor in the entrance side. (D2) having a sensor which is used to detect the location the strip film (A) is. (D3) having a sensor which is used to detect the end the strip film (A) was moved.

[0044] The inserting system (B1) of the slide mount is same as the strip film system (A2), therefore, the name, symbol of the components of the strip film system (A2) are repeated to be used again.

[0045] 50 in FIG. 2, the third opening of slide mount is located the right central portion of the cover (1). Means, strip film (A) is carried through the long hand direction of cover (1) and slide mount (B) is inserted from the direction that right vertical to the shaft line.

[0046] The width of the opening (50) is about the width of the slide mount (B), the first guide for slide mount to press plate (2) is located between the inside surface and press plate (2).

[0047] 52 in FIG. 2 is used for confirm the insertion is complete when a stop slice is lugged upward to the back of the third opening (50) of press plate (2), at the moment that the slide mount (B) is inserted into the first guide (51), the end of the slide mount (B) is connected to the first guide (52).

[0048] The components of scanning system (C) is not big difference from the device we use so far, therefore, it is shown by the FIG. 2. Projective light (62) is located downward between the end of photographic sensor which is locate the direction that the direction the cover (1) of the slide mount (B) is inserted. The picture sensor (60) is vibratory to front and back direction, the light (62) and scanner (63) is located between strip film (A) and the slide mount (B) when scanning.

[0049] [The Scanning Operation of Strip Film (A)]

[0050] When the scanning of the strip film (A), one end of strip film (A) is inserted to the first opening (11) of the cover (1). The beginning end of strip film (A) is moved in via the carrying path (42) of supporting plate (3) and the inside surface of the press plate (3) from the first opening (11), the insertion of said film (A) is detected by the entrance sensor (D1) of carrying path (42).

[0051] The signal of entrance sensor (D1) that motor (37) of the carrying mechanism (G) is started to turn and its rotating force through the timing belt (36) to transmit to the shaft (33), actuating roller (34). Consequently, strip film (A) is moved to the exit between roller (34) and the idling roller (24) of the press plate (2).

[0052] The carrying is stopped by the signal of location sensor (D2) when the strip film (a) is positioned, means the first light path (4) of the cover (1), the second light path (21) of supporting plate (2) and the third light path (31) are at the same position.

[0053] The scanning is conducted when the position of the strip film (a) is in accordance with the two light paths (21), (31), the light from the light source (62) is transmitted through two light paths (21), (31) and the strip film (A).

[0054] The scanning of the coma of the whole strip film (A) is over so far. The exit sensor (D3) is located at the supporting plate (3), the detected signal from the end of the strip film (A) is transmitted to the motor (37), the scanning of the strip film (A) is over because the motor (37) has stopped working.

[0055] The operation was shown in FIG. 6, the partial thickness inside the second opening (12) and the first opening (11) of the cover (1), is embedded to the end cutting (41) of the carrying path (42), the right position relation between the cover (1) and press plate (2) is maintained even the vibration is happened.

[0056] The carrying mechanism of strip film (A) is located at the second guide in the movable side and unified into one body. The first guide located at the way from the photographic sensor (60) of the picture of stripfilm (A) or slid mount (B) to the path. The distance of the scanner (63) of the

photographic sensor (60) is minimized, therefore, the body of the device is getting smaller.

[0057] [The Scanning Operation of the Slide Mount]

[0058] Next will be the scanning of the slide mount (B). The slide mount (B) is connected to the first guide (51) from the third opening (50).

[0059] As for the insertion of slide mount (B), the view from upper part of the first opening (11) of cover is able to judge the existence and the right position of the insertion, therefore, an identified sensor is not really necessary, it getting better of course.

[0060] The scanning is started automatically when the slid mount (B) is carried to the location in accordance with the position of two light path (21) and (31). It is possible operated by man after the scanning is started.

[0061] [Effect]

[0062] Neither the stripfilm nor slide mount is need a special scanner device. The scanning is going at the insertion of operation from the first or the second opening.

[0063] The same photographic sensor is used for scanning even the thickness of the stripfilm and slid mount is different. Therefore, the whole body of present invention is getting small.

#### BRIEF DESCRIPTION OF THE DRAWINGS

[0064] FIG. 1 is the cast view of scanning device of the example of present invention.

[0065] FIG. 2 is the expanding view of cover, press plate and supporting plate.

[0066] FIG. 3 is the front view of a scanning device from outside the case.

[0067] FIG. 4 is the side view of FIG. 3.

[0068] FIG. 5 is the view showed the insertion status of slide mount to the cover and the press plate.

[0069] FIG. 6 is the view of the embedding status of cover and supporting plate and the three layers of cover, press plate and the supporting plate.

What is claimed is:

1. A film scanning device that includes:

the first opening was located at the body which for inserting the developed strip film;

the second opening was located at the body which is an exit for the strip film which was inserted into the first opening;

the third opening was located in front of the body which is for inserting and pulling out the slide mount following the direction vertical to the direction which the strip film was moved; and

a photographic sensor which took the pictures of the strip film was inserted from the first opening and/or the slid mount was inserted from the third opening; and

a projecting light which was used to project the pictures from the photographic sensor.



2. The film scanning device as claimed in claim 1, and further including:

the first guide which combined with the main body and located at the inserting position of the slide mount was guided from the third opening;

the second guide which located at the inserting position of the strip film to set up the slid mount between it and the first guide.

3. The film scanning device as claimed in claim 2, and further including:

an carrying actuator which was used to move the strip film automatically having the carrying function; and

the first guide which located between the light path of picture from strip film or slide mount to the photographic sensor.

\* \* \* \* \*