

(19) World Intellectual Property
Organization
International Bureau



(43) International Publication Date
6 October 2005 (06.10.2005)

PCT

(10) International Publication Number
WO 2005/093135 A1

- (51) International Patent Classification⁷: C25F 3/00, 3/20, 3/22, 3/24, 3/26, 7/00
- (21) International Application Number: PCT/JP2005/006208
- (22) International Filing Date: 24 March 2005 (24.03.2005)
- (25) Filing Language: English
- (26) Publication Language: English
- (30) Priority Data:
2004-096287 29 March 2004 (29.03.2004) JP
- (71) Applicant (for all designated States except US): **EBARA CORPORATION** [JP/JP]; 11-1, Haneda Asahi-cho, Ohta-ku, Tokyo, 1448510 (JP).
- (72) Inventors; and
- (75) Inventors/Applicants (for US only): **TOMA, Yasushi** [JP/JP]; c/o Ebara Research Co., Ltd., 2-1, Honfujisawa 4-chome, Fujisawa-shi, Kanagawa, 2518502 (JP). **SAITO, Takayuki** [JP/JP]; c/o Ebara Research Co., Ltd., 2-1, Honfujisawa 4-chome, Fujisawa-shi, Kanagawa, 2518502 (JP). **HIROKAWA, Kazuto** [JP/JP]; c/o Ebara Corporation, 11-1, Haneda Asahi-cho, Ohta-ku, Tokyo, 1448510 (JP).
- (74) Agents: **WATANABE, Isamu** et al.; GOWA Nishi-Shinjuku 4F, 5-8, Nishi-Shinjuku 7-chome, Shinjuku-ku, Tokyo 160-0023 (JP).
- (81) Designated States (unless otherwise indicated, for every kind of national protection available): AE, AG, AL, AM, AT, AU, AZ, BA, BB, BG, BR, BW, BY, BZ, CA, CH, CN, CO, CR, CU, CZ, DE, DK, DM, DZ, EC, EE, EG, ES, FI, GB, GD, GE, GH, GM, HR, HU, ID, IL, IN, IS, KE, KG, KP, KR, KZ, LC, LK, LR, LS, LT, LU, LV, MA, MD, MG, MK, MN, MW, MX, MZ, NA, NI, NO, NZ, OM, PG, PH, PL, PT, RO, RU, SC, SD, SE, SG, SK, SL, SM, SY, TJ, TM, TN, TR, TT, TZ, UA, UG, US, UZ, VC, VN, YU, ZA, ZM, ZW.
- (84) Designated States (unless otherwise indicated, for every kind of regional protection available): ARIPO (BW, GH, GM, KE, LS, MW, MZ, NA, SD, SL, SZ, TZ, UG, ZM, ZW), Eurasian (AM, AZ, BY, KG, KZ, MD, RU, TJ, TM), European (AT, BE, BG, CH, CY, CZ, DE, DK, EE, ES, FI, FR, GB, GR, HU, IE, IS, IT, LT, LU, MC, NL, PL, PT, RO, SE, SI, SK, TR), OAPI (BF, BJ, CF, CG, CI, CM, GA, GN, GQ, GW, ML, MR, NE, SN, TD, TG).
- Published:
— with international search report
- For two-letter codes and other abbreviations, refer to the "Guidance Notes on Codes and Abbreviations" appearing at the beginning of each regular issue of the PCT Gazette.

(54) Title: ELECTROLYTIC PROCESSING APPARATUS

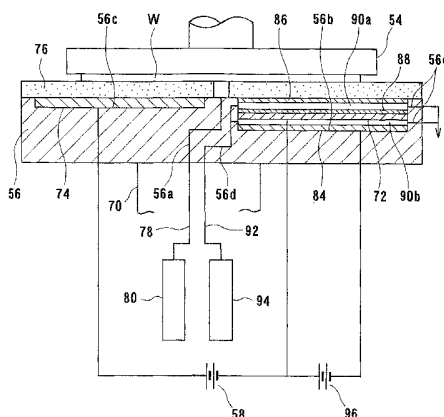

(57) Abstract: An electrolytic processing apparatus (50) has feed electrodes (74) to feed a current to a substrate (W), an ion exchanger (76) brought into contact with the substrate (W), and process electrodes (72) to perform an electrolytic process on the substrate (W). The electrolytic processing apparatus (50) has an electrolytic processing liquid source to supply an electrolytic processing liquid between the substrate (W) and the ion exchanger (76), and a regeneration liquid supply source to supply a regeneration liquid to a regeneration liquid chambers (90a, 90b). The electrolytic processing apparatus (50) includes regeneration electrodes (84) spaced from the process electrodes (72). The feed electrode (74) has a potential higher than the process electrode (72) and the same polarity as the process electrode (72). The process electrode (72) has a potential higher than the regeneration electrode (84).

WO 2005/093135 A1

DESCRIPTION
ELECTROLYTIC PROCESSING APPARATUS

Technical Field

5 The present invention relates to an electrolytic processing apparatus, and more particularly to an electrolytic processing apparatus for processing a conductive material formed on a surface of a substrate such as a semiconductor wafer or removing impurities attached to the surface of the substrate.

Background Art

10 In recent years, there has been a growing tendency to replace aluminum or aluminum alloy as a metallic material for forming interconnection circuits on a substrate such as a semiconductor wafer with copper (Cu) having a low electric resistivity and a high electromigration resistance. Copper interconnections are generally formed by filling copper into fine recesses formed in a surface of a substrate. As methods for forming copper interconnections, there have been employed chemical vapor deposition (CVD), sputtering, and plating. In any of the methods, after a copper film is formed on substantially the entire surface of a substrate, unnecessary copper is removed by chemical mechanical polishing (CMP).

15 FIGS. 1A through 1C show an example of a process of forming a copper interconnection in a substrate W. As shown in FIG. 1A, an insulating film 2, such as an oxide film of SiO₂ or a film of low-k material, is deposited on a conductive layer 1a on a semiconductor base 1 on which semiconductor devices have been formed. A contact hole 3 and an interconnection groove 4 are formed in the insulating film 2 by lithography etching technology. Then, a barrier layer 5 made of TaN or the like is formed on the insulating film 2, and a seed layer 7, which is used as a feeding layer for electrolytic plating, is formed on the barrier layer 5 by sputtering, CVD, or the like.

20 Subsequently, as shown in FIG. 1B, a surface of the substrate W is plated with copper to fill the contact hole 3 and the interconnection groove 4 with copper and to form a copper film 6 on the insulating film 2. Thereafter, the surface of the substrate W is polished by chemical mechanical polishing (CMP) to remove the copper film 6 on the insulating film 2 so that the surface of the copper film 6 filled

in the contact hole 3 and the interconnection groove 4 is made substantially even with the surface of the insulating film 2. Thus, as shown in FIG. 1C, an interconnection comprising the copper film 6 is formed in the insulating layer 2.

Recently, components in various types of equipment have become finer and have required higher accuracy. As submicronic manufacturing technology has commonly been used, the properties of the materials are greatly influenced by the machining method. Under these circumstances, in a conventional mechanical machining method in which a desired portion of a workpiece is physically destroyed and removed from a surface thereof by a tool, a large number of defects may be produced by the machining, thus deteriorating the properties of the workpiece. Accordingly, it is important to perform machining without deteriorating the properties of materials.

In copper interconnections as shown in FIG. 1C, for example, instead of a silicon oxide film, which has heretofore been used for an insulating film, a material (low-k material) having a dielectric constant lower than that of the silicon oxide film has become employed in order to prevent signal delay caused by increased capacitance between interconnections. However, since the low-k material has a low density and a low mechanical strength, conventional processing methods such as CMP employing a mechanical effect may cause separation or mechanical breakage of the low-k material.

Some processing methods, such as chemical polishing, electrochemical machining, and electrolytic polishing, have been developed in order to solve the above problem. In contrast to the conventional physical machining methods, these methods perform a removal process or the like through a chemical dissolution reaction. Accordingly, these methods do not suffer from defects such as formation of an altered layer and dislocation due to plastic deformation, so that processing can be performed without deteriorating the properties of the materials.

Recently, there has been developed an electrolytic processing apparatus employing an ion exchanger in an electrolytic process. As shown in FIG. 2, the electrolytic processing apparatus has a power supply 17, a process electrode 14 connected to the power supply 17, and a feed electrode 16 connected to the power supply 17. The process electrode 14 has an ion exchanger 12a attached to a surface thereof. The feed electrode 16 has an ion exchanger 12b attached to a

surface thereof. A liquid 18 such as pure water or ultrapure water is supplied between the electrodes 14, 16 and a workpiece 10 from a fluid supply unit 19. Then, the workpiece 10 is brought into contact with or close to the ion exchangers 12a and 12b attached to the surfaces of the electrodes 14 and 16. A voltage is applied between the process electrode 14 and the feed electrode 16 by the power supply 17. Thus, a surface of the workpiece 10 is removed.

According to the electrolytic process, water molecules 20 in the liquid 18 are dissociated into hydroxide ions 22 and hydrogen ions 24 by the ion exchangers 12a and 12b. For example, the produced hydroxide ions 22 are supplied to the surface of the workpiece 10 facing the process electrode 14. The concentration of the hydroxide ions 22 is thus increased near the workpiece 10. Atoms 10a in the workpiece 10 and the hydroxide ions 22 are reacted with each other to perform removal of a surface layer of the workpiece 10. Reactants 26 produced by the reaction are dissolved into the liquid 18 and removed from the workpiece 10 by the liquid 18 flowing along the surface of the workpiece 10.

For example, when a cation exchanger having a cation exchange group is used as an ion exchanger for a copper electrolytic process, copper is captured by the cation exchange group. Thus, the cation exchange group is consumed by copper. If copper consumes the cation exchange group, then a process product is deposited on the process electrode 14 to cause short circuit between the workpiece 10 and the process electrode 14. Accordingly, the electrolytic process cannot continuously be performed. When an anion exchanger having an anion exchange group is used as an ion exchanger for a copper electrolytic process, fine particles of copper oxide are produced on and attached to a surface of the ion exchanger (anion exchanger). Accordingly, the uniformity of a process rate is deteriorated. Further, the fine particles may contaminate a surface of a next substrate to be processed.

As a result, in an electrolytic process employing an ion exchanger, the amount of workpiece that can continuously be processed is so small that it is necessary to interrupt the electrolytic process and replace or regenerate the ion exchanger. When the ion exchanger is regenerated, ions captured in the ion exchanger are exchanged for hydrogen ions in a case of a cation exchanger or for hydroxide ions in a case of an anion exchanger.

Methods of regenerating an ion exchanger include immersing an ion

exchanger in a chemical liquid or applying a voltage that is opposite to a voltage of an electrolytic process to an ion exchanger.

For example, a method of immersing an ion exchanger in a chemical liquid is performed as follows. An acid chemical liquid is used when the ion exchanger comprises a cation exchanger. An alkali chemical liquid is used when the ion exchanger comprises an anion exchanger. The ion exchanger is immersed in such a chemical liquid. For example, in a case of a cation exchanger which has captured ions having a selectivity coefficient close to that of hydrogen ions, such as sodium ions, the ion exchanger can be regenerated for a considerably short period of time by immersion in an acid chemical liquid. When an ion exchanger which has captured ions having a large selectivity coefficient is regenerated by an acid or an alkali, a regeneration rate of the ion exchanger becomes considerably small.

Further, after regeneration of the ion exchanger, the chemical liquid remains in the ion exchanger at a high concentration. Accordingly, the ion exchanger should be cleaned. Furthermore, it is necessary to treat the chemical liquid used for regeneration. Additionally, since a separate regeneration tank should be provided to store a chemical liquid for regeneration, a large space is required to install the electrolytic processing apparatus. Further, since the process should be interrupted to regenerate the ion exchanger, a throughput of the electrolytic processing apparatus is lowered.

For example, a method of applying a voltage that is opposite to a voltage of an electrolytic process to an ion exchanger to regenerate the ion exchanger is performed as follows. After a workpiece has been processed to a certain extent, a regeneration electrode is disposed so as to face a process electrode instead of the workpiece. A voltage that is opposite to a voltage of the electrolytic process is applied to remove substances captured in the ion exchanger. In this method, it is necessary to interrupt the process to regenerate the ion exchanger. Accordingly, a throughput of the electrolytic processing apparatus is lowered.

30

Disclosure of Invention

The present invention has been made in view of the above drawbacks. It is, therefore, an object of the present invention to provide an electrolytic processing apparatus which can continuously remove ions captured in a contact member such

as an ion exchanger during processing a workpiece, and can continuously perform an electrolytic process on the workpiece while accumulation or deposition of process products is prevented in an electrode and the contact member.

According to an aspect of the present invention, there is provided an electrolytic processing apparatus which performs an electrolytic process on a
5 conductive material formed on a workpiece. The electrolytic processing apparatus has a feed electrode configured to feed an electric current to a conductive film formed on a workpiece, a contact member, such as an ion exchanger, configured to be brought into contact with or close to the workpiece, and a process electrode
10 operable to perform an electrolytic process on the conductive material of the workpiece. The electrolytic processing apparatus also has an electrolytic processing liquid source configured to supply an electrolytic processing liquid between the workpiece and the contact member, a regeneration liquid chamber for immersing the process electrode in a regeneration liquid, and a regeneration liquid
15 supply source configured to supply the regeneration liquid to the regeneration liquid chamber. The electrolytic processing apparatus includes a regeneration electrode spaced from the process electrode and a power supply operable to apply a voltage between the feed electrode, the process electrode, and the regeneration electrode. The electrolytic processing apparatus also includes a controller operable to control
20 the voltage applied between the feed electrode, the process electrode, and the regeneration electrode so that the feed electrode has a potential higher than the process electrode and the same polarity as the process electrode, and that the process electrode has a potential higher than the regeneration electrode.

Thus, the ion exchanger is brought into contact with or close to the
25 workpiece while an electric current is fed to the workpiece. The electrolytic processing liquid is supplied between the workpiece and the process electrode. For example, a first voltage is applied between the process electrode and the feed electrode, and a second voltage is applied between the process electrode and the regeneration electrode. Accordingly, an electrolytic process by the process
30 electrode and a regeneration process of the ion exchanger by the regeneration electrode can be performed simultaneously. A first voltage may be applied between the feed electrode and the regeneration electrode, and a second voltage may be applied between the process electrode and the regeneration electrode.

Alternatively, a first voltage may be applied between the feed electrode and the process electrode, and a second voltage may be applied between the feed electrode and the regeneration electrode.

The electrolytic processing apparatus may include an insulation member disposed between the contact member (ion exchanger) and the process electrode. The insulation member has liquid permeability. With this arrangement, ionic process products or ionic impurities captured in the ion exchanger during processing can be moved through the insulation member toward the process electrode by electrophoresis and dissolved in the regeneration liquid. The ionic process products or ionic impurities are discharged to the exterior of the system by the flow of the regeneration liquid or moved toward the regeneration electrode by electrophoresis using the power supply and deposited on the regeneration electrode. Thus, even if deposition occurs on the process electrode, the deposition does not reach the ion exchanger. Accordingly, no short circuits are caused between the process electrode and the workpiece.

It is desirable that the electrolytic processing liquid comprises ultrapure water, pure water, a liquid having an electric conductivity of 500 $\mu\text{S}/\text{cm}$ or less, or an electrolytic solution. For example, ultrapure water has an electric conductivity of 0.1 $\mu\text{S}/\text{cm}$ or less. In this case, the electric conductivity is represented as a converted value at 1 atm and 25°C. This also holds true in the following examples. For example, pure water has an electric conductivity of 10 $\mu\text{S}/\text{cm}$ or less. Thus, with pure water, preferably ultrapure water, a clean electrolytic process can be achieved while no impurities remain on a surface of the workpiece. Accordingly, subsequent processes of cleaning the surface of the workpiece and treating a waste liquid can be simplified.

For example, an additive such as a surface active agent may be added into pure water or ultrapure water to adjust the electric conductivity at 500 $\mu\text{S}/\text{cm}$ or less, preferably 50 $\mu\text{S}/\text{cm}$ or less, more preferably 0.1 $\mu\text{S}/\text{cm}$ or less. Thus, when an additive which serves to prevent ions from being locally concentrated is added, ions are prevented from being locally concentrated. For example, the electrolytic solution may comprise a solution of a neutral salt such as NaCl or Na_2SO_4 , a solution of an acid such as HCl or H_2SO_4 , or a solution of an alkali such as ammonia. The electrolytic solution can be selectively used according to the

properties of the workpiece.

The electrolytic processing apparatus may include a diaphragm disposed between the contact member and the insulation member so as to separate the electrolytic processing liquid and the regeneration liquid. The diaphragm may
5 comprise an ion exchange film. With such an arrangement, the regeneration liquid can comprise a different liquid than the electrolytic processing liquid. Accordingly, a liquid which is unlikely to cause deposition or accumulation of process products or impurities can be used as the regeneration liquid.

It is desirable that the diaphragm comprises a cation exchanger when the
10 contact member comprises a cation exchanger. It is also desirable that the diaphragm comprises an anion exchanger when the contact member comprises an anion exchanger. At that time, positive ions in the contact member of the cation exchanger pass through the cation exchanger of the diaphragm and reach the regeneration liquid. The positive ions are dissolved in the regeneration liquid and
15 removed. Similarly, negative ions in the contact member of the anion exchanger pass through the anion exchanger of the diaphragm and reach the regeneration liquid. The negative ions are dissolved in the regeneration liquid and removed.

The controller may be operable to control potentials of the feed electrode, the process electrode, and the regeneration electrode, or currents flowing through
20 the feed electrode, the process electrode, and the regeneration electrode. The current flowing through the feed electrode exerts a great influence on a processing rate, and the current flowing through the process electrode exerts a great influence on a tendency unlikely to cause deposition or accumulation of process products or impurities. Accordingly, by controlling the current flowing through the feed
25 electrode and the current flowing through the process electrode, it is possible to control a processing rate or a tendency unlikely to cause deposition or accumulation of process products or impurities.

For example, a tendency unlikely to cause deposition or accumulation of process products or impurities will be described below. When copper is processed
30 while the feed electrode serves as an anode and the process electrode serves as a cathode, deposits accumulate on the process electrode in several minutes. Thus, a short circuit occurs between the process electrode and the feed electrode. Accordingly, it becomes impossible to continue the electrolytic process. However,

when the process electrode serves as an anode (which is the same polarity as the feed electrode), an electrolytic process can be continued for at least several hours without any short circuit between the process electrode and the feed electrode. The anode is defined as an electrode from which positive charges flow toward the electrolytic processing liquid. The cathode is defined as an electrode into which positive charges flow from the electrolytic processing liquid. Accordingly, it is important that a current flows through the process electrode in a fixed direction continuously during processing. Specifically, it is important to maintain the polarity of the process electrode (so as to have the same polarity as the feed electrode). Thus, it is desirable to control a current or a voltage at a constant value to maintain the polarity of the process electrode.

In this case, it is desirable that the current flowing through the process electrode is controlled so as to be equal to 1 to 30 % of the current flowing through the feed electrode or the regeneration electrode. As a larger current flows through the process electrode, deposition of impurities can be prevented more effectively. Usually, 1 to 30 % of the current flowing through the feed electrode or the regeneration electrode is sufficient for the current flowing through the process electrode. In consideration of consumed energy and process cost, it is desirable that the current flowing through the process electrode is in a range of 1 to 10 %, preferably 1 to 3 % of the current flowing through the feed electrode or the regeneration electrode.

According to the present invention, process products can readily and immediately be removed from the contact member such as an ion exchanger during an electrolytic process. It is possible to prevent accumulation or deposition of process products within the electrode and the contact member. Accordingly, it is possible to reduce or eliminate a period of time during which the electrolytic process is interrupted to regenerate the contact member. Thus, the efficiency of the electrolytic processing apparatus can be improved.

The above and other objects, features, and advantages of the present invention will be apparent from the following description when taken in conjunction with the accompanying drawings which illustrate preferred embodiments of the present invention by way of example.

Brief Description of Drawings

FIGS. 1A through 1C are diagrams showing an example of a process of forming a copper interconnection in a substrate;

FIG. 2 is a schematic view showing a principle of an electrolytic process employing an ion exchanger;

FIG. 3 is a vertical cross-sectional view showing an electrolytic processing apparatus according to an embodiment of the present invention;

FIG. 4 is a partial enlarged view of the electrolytic processing apparatus shown in FIG. 3;

FIG. 5A is a circuit diagram showing electric connection in the electrolytic processing apparatus shown in FIGS. 3 and 4; and

FIGS. 5B and 5C are circuit diagrams showing variations of the electric connection shown in FIG. 5A.

Best Mode for Carrying Out the Invention

An electrolytic processing apparatus according to an embodiment of the present invention will be described below with reference to FIGS. 3 through 5C. Like or corresponding parts are denoted by like or corresponding reference numerals throughout drawings, and will not be described below repetitively. In the following description, a substrate is processed as a workpiece by an electrolytic processing apparatus. However, the present invention is applicable to any workpiece other than a substrate.

FIG. 3 is a vertical cross-sectional view showing an electrolytic processing apparatus 50 according to an embodiment of the present invention. The electrolytic processing apparatus 50 has an arm 52 extending in a horizontal direction, a substrate holder 54 attached to a free end of the arm 52, and a circular electrode table 56 disposed below the substrate holder 54. The arm 52 is movable in a vertical direction and swingable in a horizontal direction. The substrate holder 54 attracts and holds a workpiece W such as a substrate in a state such that the substrate W faces downward (in a face-down manner).

The electrolytic processing apparatus 50 also has a swing shaft 62 coupled to a swing motor 60. The arm 52 is attached to an upper end of the swing shaft 62. Thus, when the swing motor 60 is driven, the arm 52 is swung in the horizontal

direction so as to pivot about the swing shaft 62. The swing shaft 62 is coupled to a ball screw 64 extending in the vertical direction. The ball screw 64 is connected to a vertical movement motor 66. Thus, when the vertical movement motor 66 is driven, the swing shaft 62 is moved vertically together with the arm 52.

5 The substrate holder 54 is coupled to a rotation motor 68 mounted on the arm 52. The rotation motor 68 serves as a first driving mechanism for moving the substrate W held by the substrate holder 54 and the electrode table 56 relative to each other. Thus, when the rotation motor 68 is driven, the substrate holder 54 is rotated. Further, since the arm 52 is vertically movable and horizontally swingable as described above, the substrate holder 54 is movable in the vertical
10 direction and swingable in the horizontal direction together with the arm 52.

 The electrolytic processing apparatus 50 includes a hollow motor 70 disposed below the electrode table 56. The hollow motor 70 serves as a second driving mechanism for moving the substrate W and the electrode table 56 relative to
15 each other. Thus, when the hollow motor 70 is driven, the substrate W and the electrode table 56 make a scroll movement or a translational rotation movement.

 The electrode table 56 includes process electrodes 72, feed electrodes 74, and an insulator (not shown) disposed around the process electrodes 72 and the feed electrodes 74. For example, the process electrodes 72 and the feed electrodes 74
20 may have a sectorial shape. The process electrodes 72 and the feed electrodes 74 are embedded alternately in the electrode table 56 in a manner such that (upper) surfaces of the electrodes 72 and 74 are exposed from the electrode table 56. The surfaces of the electrodes 72 and 74 are covered integrally with an ion exchanger 76. When the process electrodes 72 and the feed electrodes 74 are divided along a
25 circumferential direction of the electrode table 56 and alternately arranged in the electrode table 56, it is possible to eliminate a fixed portion for feeding an electric current to a conductive film of the substrate W (workpiece). Thus, it is possible to process the entire surface of the substrate W. In the present embodiment, the electrode table 56 including the process electrodes 72 and the feed electrodes 74 has
30 a diameter slightly larger than the diameter of the substrate W held by the substrate holder 54. Since the electrode table 56 makes a scroll movement, the entire surface of the substrate W is subjected to an electrolytic process.

 For example, the ion exchanger 76 on the electrode table 56 may be formed

of a nonwoven fabric having an anion exchange function or a cation exchange function. Preferably, the cation exchanger has a strongly acidic cation exchange group (e.g., sulfonic acid group). Alternatively, the cation exchanger may have a weakly acidic cation exchange group (e.g., carboxyl group). Preferably, the anion exchanger has a strongly basic anion exchange group (e.g., quaternary ammonium group). Alternatively, the anion exchanger may have a weakly basic anion exchange group (e.g., tertiary or lower ammonium group).

For example, a nonwoven fabric having a strongly basic anion exchange function can be prepared as follows. Graft chains are introduced into a polyolefin nonwoven fabric having a fiber diameter of 20 to 50 μm and a porosity of about 90 % with the use of radiation-induced graft polymerization, which comprises gamma irradiation and graft polymerization. Then, the introduced graft chains are aminated to introduce a quaternary ammonium group to thereby form a nonwoven fabric having a strongly basic anion exchange function. The capacity of the introduced ion exchange group is determined according to the amount of graft chains introduced. The graft polymerization may be conducted by the use of a monomer such as acrylic acid, styrene, glycidyl methacrylate, sodium styrenesulfonate, or chloromethylstyrene. The amount of the graft chains can be controlled by adjusting the monomer concentration, the reaction temperature, and the reaction time. A graft ratio, which is a ratio of the weight of a material after graft polymerization to the weight thereof before the graft polymerization, can be increased to about 500 % at maximum. The exchange capacity of the ion exchange group introduced by graft polymerization can be increased to about 5 meq/g at maximum.

For example, a nonwoven fabric having a strongly acidic cation exchange function can be prepared as follows. Graft chains are introduced into a polyolefin nonwoven fabric having a fiber diameter of 20 to 50 μm and a porosity of about 90 % with the use of radiation-induced graft polymerization, which comprises gamma irradiation and graft polymerization. Then, the introduced graft chains are treated with heated sulfuric acid to introduce a sulfonic acid group to thereby form a nonwoven fabric having a strongly acidic cation exchange function. Such a nonwoven fabric can have a graft ratio of about 500 % at maximum. The exchange capacity of the ion exchange group introduced by graft polymerization

can be increased to about 5 meq/g at maximum.

The ion exchanger 76 may be formed of polyolefin such as polyethylene or polypropylene, or any other organic polymers. Further, the ion exchanger 76 may be in the form of a woven fabric, a sheet, a porous material, short fibers, a net, or the like. In a case of the graft polymerization of polyethylene or polypropylene, a radioactive ray (γ -ray or electron beam) may be applied to a material for pre-irradiation to generate a radical so that the radical reacts with a monomer. In this case, it is possible to produce uniform graft chains which have fewer impurities. Alternatively, a material may be impregnated with a monomer and irradiated with a radioactive ray (γ -ray, electron beam, or ultraviolet ray) for simultaneous irradiation to perform a radical polymerization. In this method, the uniformity of graft chains may be lowered, but can be applied to almost all materials.

Thus, when the ion exchanger 76 is formed of a nonwoven fabric having an anion exchange function or a cation exchange function, the water permeability can be provided so that a liquid, such as pure water, ultrapure water, or an electrolytic solution, can move within the nonwoven fabric without any interruption. Accordingly, ion exchange reaction is readily performed between ions in liquid phase and an ion exchange group in the ion exchanger 76.

If the ion exchanger 76 is formed of a material having only one of an anion exchange function and a cation exchange function, types of materials that can be subjected to an electrolytic process are limited. Further, impurities are likely to be produced by its polarity. Accordingly, the ion exchanger 76 may have a structure in which cation exchangers having a cation exchange function and anion exchangers having an anion exchange function are concentrically arranged. Alternatively, anion exchangers having an anion exchange function and cation exchangers having an anion exchange function may be piled on each other. Further, anion exchangers and cation exchangers may be formed into sectorial shapes and disposed alternately in a circumferential direction. Furthermore, the ion exchanger 76 may have both of an anion exchange function and a cation exchange function. Such an ion exchanger may include an amphoteric ion exchanger having anion exchange groups and cation exchange groups which are distributed in a desired manner, a bipolar ion exchanger having anion exchange groups and cation exchange groups in the form of layers, and a mosaic ion

exchanger having portions containing anion exchange groups and portions containing cation exchange groups in parallel in a thickness direction. It is possible to selectively use an ion exchanger having an anion exchange function or an ion exchanger having a cation exchange function according to the material to be processed.

FIG. 4 is a partial enlarged view of the electrolytic processing apparatus 50 shown in FIG. 3. As shown in FIG. 4, the electrode table 56 has a through-hole 56a defined at a central portion thereof and an electrolytic processing liquid supply pipe 78 for supplying an electrolytic processing liquid, such as pure water, preferably ultrapure water, to the through-hole 56a. The electrolytic processing liquid supply pipe 78 extends through a hollow portion of the hollow motor 70. The through-hole 56a is connected through the electrolytic processing liquid supply pipe 78 to an electrolytic processing liquid supply source 80. Thus, the electrolytic processing liquid is supplied through the through-hole 56a to an upper surface of the electrode table 56 and is then supplied through the ion exchanger 76 having water absorbing properties to the entire surface of the substrate W.

For example, pure water has an electric conductivity of 10 $\mu\text{S}/\text{cm}$ or less, and ultrapure water has an electric conductivity of 0.1 $\mu\text{S}/\text{cm}$ or less. A liquid having an electric conductivity of 500 $\mu\text{S}/\text{cm}$ or less, or various electrolytic solutions may be used instead of pure water. By supplying such a liquid during processing, unstableness of the process, which is caused by process products or gas dissolution, can be eliminated so as to achieve a uniform process with high reproducibility.

A liquid having an electric conductivity of 500 $\mu\text{S}/\text{cm}$ or less (e.g., an electrolytic solution in which an electrolyte is added into pure water or ultrapure water) can be used instead of pure water or ultrapure water. The use of the electrolytic solution can reduce an electric resistance and hence electric power consumption. The electrolytic solution may comprise a solution of a neutral salt such as NaCl or Na_2SO_4 , a solution of an acid such as HCl or H_2SO_4 , or a solution of an alkali such as ammonia. The electrolytic solution can be selectively used according to the properties of the workpiece. When the electrolytic solution is used, it is desirable to form a slight gap between the substrate W and the ion exchanger 76 so that the substrate W is not brought into contact with the ion

exchanger 76.

Further, instead of pure water or ultrapure water, there may be used a liquid in which a surface active agent is added into pure water or ultrapure water so as to have an electric conductivity of 500 $\mu\text{S}/\text{cm}$ or less, preferably 50 $\mu\text{S}/\text{cm}$ or less, more preferably 0.1 $\mu\text{S}/\text{cm}$ or less (a resistivity of 10 $\text{M}\Omega\cdot\text{cm}$ or less). By adding a surface active agent into pure water or ultrapure water, a uniform layer can be formed at an interface between the substrate W and the ion exchanger 76 to moderately inhibit ion migration. Thus, concentrated ion exchange (metal dissolution) can be moderated so as to enhance flatness of the surface of the substrate W. The concentration of the surface active agent is preferably 100 ppm or less. If the liquid has an excessively high electric conductivity, a current efficiency and a processing rate are lowered. The use of the liquid having an electric conductivity of 500 $\mu\text{S}/\text{cm}$ or less, preferably 50 $\mu\text{S}/\text{cm}$ or less, more preferably 0.1 $\mu\text{S}/\text{cm}$ or less, can provide a desired processing rate.

In the present embodiment, a plurality of sectorial electrodes 72 and 74 are embedded along a circumferential direction on an upper surface of the electrode table 56. As shown in FIG. 3, the electrodes 72 and 74 are connected through a control box (controller) 82 to a cathode and an anode of a power supply 58, respectively. The electrodes connected to the cathode of the power supply 58 serve as process electrodes while the electrodes connected to the anode of the power supply 58 serve as feed electrodes. This is because an electrolytic process is performed on the cathode side in a case of copper. Depending upon a material to be processed, the electrodes connected to the cathode may serve as feed electrodes while the electrodes connected to the anode may serve as process electrodes. Specifically, when the material to be processed is copper, molybdenum, or iron, an electrolytic process is performed on the cathode side. Accordingly, the electrodes connected to the cathode of the power source 58 serve as the process electrodes while the electrodes connected to the anode serve as the feed electrodes. When the material to be processed is aluminum or silicon, an electrolytic process is performed on the anode side. Accordingly, the electrodes connected to the anode serve as the process electrodes while the electrodes connected to the cathode serve as the feed electrodes.

Generally, oxidation or dissolution of the process electrodes 72 and the

feed electrodes 74 problematically occurs due to an electrolytic reaction. Accordingly, it is desirable that the electrodes are made of carbon, a noble metal that is relatively inactive, a conductive oxide, or a conductive ceramics, rather than metal or metal compound, which has widely been used for electrodes. For
5 example, in order to produce a noble metal-based electrode, a titanium electrode may be plated or coated with platinum or iridium and then sintered at a high temperature to stabilize and strengthen the electrode. Generally, inorganic raw materials are subjected to heat treatment to produce ceramics products. Ceramics products having various properties are produced from various raw materials
10 including oxides, carbides, and nitrides of metals and nonmetals. Some ceramics have an electric conductivity. When an electrode is oxidized, the electric resistance of the electrode is increased to thereby cause an increase of an applied voltage. However, by protecting the surface of an electrode with a non-oxidative material such as platinum or with a conductive oxide such as an iridium oxide, the
15 electric resistance of the electrode can be prevented from being increased due to oxidation of the electrode.

When the ion exchanger 76 has a cation exchange group to perform a copper electrolytic process, copper occupies most of ion exchange groups in the ion exchanger (cation exchanger) 76 after the electrolytic process. Accordingly, a
20 process efficiency is lowered when a next substrate is processed. Alternatively, process products are deposited on the process electrodes 72 to cause a short circuit between the substrate W and the process electrodes 72. Thus, it is difficult to continuously perform an electrolytic process. Further, when ion exchanger 76 has an anion exchange group to perform a copper electrolytic process, fine particles of
25 copper oxides are produced on and attached to a surface of the ion exchanger (anion exchanger) 76. Accordingly, the fine particles of copper oxides may contaminate a surface of a next substrate. In the present embodiment, a cation exchanger is used as the ion exchanger 76 and regenerated at a location between the process electrodes 72 and the substrate W in the following manner.

30 As shown in FIG. 4, each of the process electrodes 72 is housed in a recess 56b formed in the electrode table 56, and each of the feed electrodes 74 is housed in a recess 56c formed in the electrode table 56. The recess 56b which houses the process electrode 72 has a depth greater than that of the recess 56c which houses

the feed electrode 74. Regeneration electrode 84 for regenerating the ion exchanger 76 is disposed at a bottom of the recess 56b.

The recess 56b has an upper opening covered with a diaphragm 86. Further, an insulation member 88 is disposed on an upper surface of the process electrode 72. Each of the insulation member 88 and the process electrode 72 has liquid permeability. In the present embodiment, the process electrode 72 is formed of an electrode having a large number of meshes, which serve as through-holes. As shown in FIG. 4, the diaphragm 86 is spaced from the insulation member 88 so as to form a regeneration liquid chamber 90a between the process electrode 72 and the diaphragm 86. The regeneration electrode 84 is spaced from the process electrode 72 so as to form a regeneration liquid chamber 90b between the process electrode 72 and the regeneration electrode 84.

The regeneration liquid chambers 90a and 90b are connected to a regeneration liquid supply passage 56d, which extends through the electrode table 56. The regeneration liquid supply passage 56d is connected through a regeneration liquid supply pipe 92, which extends through the hollow portion of the hollow motor 70, to a regeneration liquid supply source 94. Peripheral portions of the regeneration liquid chambers 90a and 90b are also connected to regeneration liquid discharge passages 56e. The regeneration liquid discharge passages 56e extend in the horizontal direction and open at peripheral edges of the electrode table 56.

With such an arrangement, a regeneration liquid is supplied through the regeneration liquid supply passage 56d into the regeneration liquid chambers 90a and 90b. Thus, the interiors of the regeneration liquid chambers 90a and 90b are filled with the regeneration liquid so as to immerse the process electrode 72 and the insulation member 88 in the regeneration liquid. The regeneration liquid flows in one direction within the regeneration liquid chambers 90a and 90b. Then, the regeneration liquid is discharged through the regeneration liquid discharge passages 56e to the exterior of the electrode table 56.

As described above, the process electrode 72 is formed of an electrode having a large number of meshes which serve as through-holes. Accordingly, process products in the form of ions (ionic impurities) which have been produced from the ion exchanger 76 pass through the meshes (through-holes) in the process

electrode 72 into the regeneration liquid chamber 90b.

Preferably, the regeneration liquid to be supplied into the regeneration liquid chambers 90a and 90b comprises a liquid that has a high electric conductivity (dielectric constant) of, for example, at least 50 $\mu\text{S}/\text{cm}$ and is unlikely to generate insoluble compounds by reaction with ions that have been removed from the ion exchanger 76. Specifically, the regeneration liquid serves to discharge ions that have moved from the ion exchanger 76 and passed through the diaphragm 86 and the process electrode 72 to the exterior of the electrode table 56 by the liquid flow. Thus, when the regeneration liquid comprises a liquid that has a high electric conductivity (dielectric constant) and is unlikely to generate insoluble compounds by reaction with ions that have been removed from the ion exchanger 76, the electric resistance of the regeneration liquid can be lowered so as to reduce the electric power consumption in the regeneration liquid chambers 90a and 90b. Further, refractory or insoluble compounds (by-products) are prevented from being generated by reaction with ions that have been removed from the ion exchanger 76 and from being attached to the diaphragm 86. The regeneration liquid is selectively used according to types of ionic impurities to be removed. For example, when an ion exchanger that has been used for a copper electrolytic process is regenerated, the regeneration liquid may comprise sulfuric acid having a concentration of at least 1 wt %.

It is desirable that the diaphragm 86, which is disposed below the ion exchanger 76, does not interfere with movement of ionic impurities to be removed from the ion exchanger 76. Further, it is desirable that the diaphragm 86 can prevent a regeneration liquid (including ions therein) flowing through the regeneration liquid chamber 90a between the diaphragm 86 and the insulation member 88 from permeating the diaphragm 86 into the ion exchanger 76. Materials that can meet such requirements include a membranous ion exchanger such as NafionTM (by DuPont). Such an ion exchanger allows anions or cations to selectively permeate the diaphragm 86. Further, since the ion exchanger is membranous, the regeneration liquid is prevented from flowing from the regeneration liquid chamber 90a into the ion exchanger 76.

In the present embodiment, the diaphragm 86 comprises an ion exchanger having the same ion exchange group as the ion exchanger 76, i.e. a cation

exchanger. Accordingly, the diaphragm (ion exchanger) 86 can allow only ions from the ion exchanger (cation exchanger) 76 to permeate the diaphragm 86. The ions in the regeneration liquid flowing through the regeneration liquid chamber 90a are prevented from permeating the diaphragm (ion exchanger) 86 into the ion exchanger 76. If the ion exchanger 76 comprises an anion exchanger having an anion exchange group, it is desirable to use an anion exchanger as the diaphragm (ion exchanger) 86.

The insulation member 88 having liquid permeability should be insoluble in the regeneration liquid. In the present embodiment, the insulation member 88 comprises a fluorocarbon resin sheet having a thickness of about 0.1 mm, which has a large number of holes having a diameter of about 2 mm. Process products are deposited on the process electrode 72 and subsequently deposited in the ion exchanger 76. Specifically, the process products extend through the ion exchanger 76 and reach the substrate W to cause a short circuit between the process electrode 72 and the substrate W. In the case where the insulation member 88 having liquid permeability is disposed between the process electrode 72 and the ion exchanger 76, even if deposition occurs on the process electrode 72, the deposition does not reach the ion exchanger 76. Accordingly, a short circuit is not caused between the process electrode 72 and the substrate W.

In the present embodiment, the feed electrodes 74 are connected to the anode of the power supply 58, and the process electrodes 72 are connected to the cathode of the power supply 58. The power supply 58 supplies a process voltage between the feed electrodes 74 and the process electrodes 72. The process electrodes 72 and the regeneration electrodes 84 are connected through the control box (not shown) to the anode and the cathode of a power supply 96, respectively. The power supply 96 supplies a regeneration voltage between the process electrode 72 and the regeneration electrode 84.

The control box (see FIG. 3) connected to the power supply 58 and the control box (not shown) connected to the power supply 96 adjust a process voltage and a regeneration voltage so that a potential of the feed electrode 74 is higher than that of the process electrode 72, and the potential of the process electrode 72 is higher than that of the regeneration electrode 84. The control boxes also adjust the process voltage and the regeneration voltage so that the feed electrode 74 has the

same polarity as the process electrode 72. In the present embodiment, the polarities of the feed electrode 74 and the process electrode 72 are anodic. Specifically, positive charges flow from the feed electrode 74 and the process electrode 72 into an electrolytic processing liquid. Accordingly, process products (ions) which accumulate on the ion exchanger 76 can continuously be discharged. As a result, the electrolytic process can be continued for a long term.

In the present embodiment, the feed electrode 74, the process electrode 72, and the regeneration electrode 84 are electrically connected in series. The control boxes independently control a current flowing through the feed electrode 74, a current flowing through the process electrode 72, a current flowing through the regeneration electrode 84, a potential of the feed electrode 74, a potential of the process electrode 72, and a potential of the regeneration electrode 84. Thus, ionic impurities can be discharged from the ion exchanger 76 during the electrolytic process. Accordingly, the electrolytic process can continuously be performed. Particularly, it is desirable to control a current flowing through the process electrode 72 so as to be equal to 1 to 30 % of a current flowing through the feed electrode 74 or the regeneration electrode 84.

In the present embodiment, as shown in FIG. 5A, the feed electrode 74, the process electrode 72, and the regeneration electrode 96 are electrically connected in series to the power supply 58 and the power supply 96. However, connection of the electrodes and the power supplies is not limited to the illustrated example. As shown in FIG. 5B, for example, the feed electrode 74 may be connected to an anode of a first power supply 97a while the regeneration electrode 84 may be connected to a cathode of the first power supply 97a. The process electrode 72 may be connected to an anode of a second power supply 97b while the regeneration electrode 84 may be connected to a cathode of the second power supply 97b. Alternatively, as shown in FIG. 5C, the feed electrode 74 may be connected to an anode of a first power supply 98a while the regeneration electrode 84 may be connected to a cathode of the first power supply 98a. The feed electrode 74 may be connected to an anode of a second power supply 98b while the process electrode 72 may be connected to a cathode of the second power supply 98b. According to connections shown in FIGS. 5B and 5C, a potential of the process electrode 72 can accurately be set and controlled by accurately controlling a voltage of the second

power supply 97b or 98b.

Further, when the process electrode 72 is disposed close to the ion exchanger 76 so that the process electrode 72 has the same potential as the ion exchanger 76, variations of an electric field can be prevented so as to reduce an adverse influence from deposits or air bubbles. In order to uniformly perform an electrolytic process and a regeneration process, the surface of the substrate W, the process electrode 72, and the regeneration electrode 84 are preferably disposed in parallel to each other. It is desirable that the whole ion exchanger 76 has a uniform thickness.

There will be described substrate processing (an electrolytic process and a regeneration process) employing the electrolytic processing apparatus 50. First, the substrate holder 54 of the electrolytic processing apparatus 50 attracts and holds a substrate W. The arm 52 is swung to move the substrate holder 54 holding the substrate W to an electrolytic process position located right above the electrode table 56. Then, the vertical movement motor 66 is driven to lower the substrate holder 54. Thus, the substrate W held by the substrate holder 54 is brought into contact with or close to a surface of the ion exchanger 76 attached to the upper surface of the electrode table 56.

At that time, the rotation motor 68 is driven to rotate the substrate W. Simultaneously, the hollow motor 70 is driven so that the electrode table 56 makes a scroll movement. An electrolytic processing liquid such as pure water or ultrapure water is supplied from the through-hole 56a in the electrode table 56 to the upper surface of the electrode table 56. Thus, a space between the process electrode 72, the feed electrode 74, and the substrate W is filled with pure water, ultrapure water, a liquid of 500 $\mu\text{S}/\text{cm}$ or less, or an electrolytic solution. The power supply 58 applies a process voltage between the process electrode 72 and the feed electrode 74. Thus, hydrogen ions or hydroxide ions generated by the ion exchanger 76 perform an electrolytic process on a conductive film (e.g., a copper film 6 shown in FIG. 1B) formed on a surface of the substrate W at the process electrode (cathode). Since the electrolytic processing apparatus 50 is configured so that the electrolytic processing liquid such as pure water or ultrapure water flows through the ion exchanger 76, an efficient electrolytic process can be achieved.

At that time, a regeneration liquid for the ion exchanger 76 is supplied

through the regeneration liquid supply passage 56d in the electrode table 56 into the regeneration liquid chambers 90a and 90b. Thus, the regeneration liquid chambers 90a and 90b are filled with the regeneration liquid so as to immerse the process electrode 72 and the insulation member 88 in the regeneration liquid. The
5 regeneration liquid flows through the regeneration liquid chambers 90a and 90b in a radially outward direction and is discharged from the regeneration liquid discharge passages 56e to the exterior of the electrode table 56.

Accordingly, ions in the ion exchanger 76 are moved toward the process electrode 72 by ion exchange reaction employing the ion exchanger 76 as a solid
10 electrolyte. The ions in the ion exchanger 76 pass through the diaphragm 86 into the regeneration liquid chamber 90a. The ions moved to the regeneration liquid chamber 90a are discharged to the exterior of the electrode table 56 by the regeneration liquid flowing through the regeneration liquid chamber 90a. Thus, the ion exchanger 76 is regenerated. At that time, when a cation exchanger is used
15 as the ion exchanger 76, cations captured in the ion exchanger 76 are moved through the diaphragm 86 into the regeneration liquid chamber 90a. When an anion exchanger is used as the ion exchanger 76, anions captured in the ion exchanger 76 are moved through the diaphragm 86 into the regeneration liquid chamber 90a.

20 Further, a regeneration voltage is applied between the process electrode 72 and the regeneration electrode 84 during processing by the power supply 96 to force a current to flow between the process electrode 72 and the regeneration electrode 84. Thus, ionic process products (ionic impurities) accumulating in the ion exchanger 76 can be moved through the process electrode 72 into the regeneration liquid
25 chamber 90b. The ions moved to the regeneration liquid chamber 90b are discharged to the exterior of the electrode table 56 by the regeneration liquid supplied to the regeneration liquid chamber 90b or deposited on the regeneration electrode 84. Thus, the ion exchanger 76 can be regenerated.

30 As described above, since the diaphragm 86 comprises an ion exchanger having the same ion exchange group as the ion exchanger 76, the diaphragm (ion exchanger) 86 is prevented from inhibiting movement of ionic impurities in the ion exchanger 76 through the diaphragm (ion exchanger) 86. Thus, electric power consumption can be reduced. Further, the regeneration liquid (including ions

therein) flowing between the diaphragm 86 and the process electrode 72 is prevented from permeating the diaphragm 86 into the ion exchanger 76. Thus, re-contamination of the ion exchanger 76 can be prevented after the regeneration. Furthermore, since the regeneration liquid supplied between the diaphragm 86 and the process electrode 72 has a high electric conductivity and is unlikely to generate insoluble compounds by reaction with ions removed from the ion exchanger 76, the electric power consumption in the regeneration section can be reduced by a lowered electric resistance of the regeneration liquid. Additionally, insoluble compounds (by-products) produced by reaction with ionic impurities can be prevented from being attached to the diaphragm 86. Accordingly, the electric resistance can be prevented from being varied between the process electrode 72 and the feed electrode 74. Thus, difficulties in control can be eliminated.

After completion of the electrolytic process, electrical connection is interrupted between the power supply 58, the process electrode 72, and the feed electrode 74, and between the power supply 96, the process electrode 72, and the regeneration electrode 84. Further, the rotation of the substrate holder 54 and the scroll movement of the electrode table 56 are stopped. Then, the substrate holder 54 is raised, and the arm 52 is moved to transfer the substrate W that has been subjected to the electrolytic process into a subsequent process.

As described above, in the present embodiment, pure water, preferably ultrapure water is supplied between the electrode table 56 and the substrate W. When an electrolytic process is performed with pure water or ultrapure water, which contains no electrolytes, it is possible to prevent excessive impurities such as electrolytes from being attached onto or remaining on a surface of the substrate W. Further, copper ions dissolved by the electrolytic process can immediately be captured by the ion exchanger 76 through the ion exchange reaction. Accordingly, dissolved copper ions are prevented from being deposited on other portions of the substrate W and from oxidized and converted into fine particles which would contaminate the surface of the substrate W.

Ultrapure water has a large specific resistance, and a current is unlikely to flow through ultrapure water. Accordingly, in order to reduce an electric resistance, the electrode and the workpiece are disposed at nearest positions, or an ion exchanger is disposed between the electrode and the workpiece. With the

above electrolytic solution, the electric resistance can further be reduced, and thus the electric power consumption can be reduced. In the process using an electrolytic solution, the workpiece is processed at an area that is slightly larger than the process electrode. However, with a combination of ultrapure water and
5 an ion exchanger, since a current hardly flows through ultrapure water, the workpiece is processed only at an area that faces the process electrode and the ion exchanger.

If a process voltage and a current density are increased in order to increase a processing rate, electric charge may occur in a case of a large electric resistance
10 between the electrode and the substrate (workpiece). Such electric charge causes pitching on a surface of the workpiece, thereby making it difficult to maintain uniformity or planarization of the surface of the workpiece. However, when the ion exchanger 76 is brought into contact with the substrate W, the electric resistance is so small that electric charge can be prevented from being caused.

In the present embodiment, the feed electrodes serve as an anode to process
15 copper. However, when the feed electrodes are configured to serve as a cathode, a removal process of aluminum or silicon can be performed. In this case, the feed electrodes and the process electrodes are configured to have the same polarity. Specifically, when the process electrodes are configured to serve as a cathode, into
20 which positive charges flow from an electrolytic processing liquid, ionic process products accumulating on the ion exchanger 76 can continuously be discharged. Accordingly, an electrolytic process can be continued for a long term.

Further, in the above embodiment, the electrode table 56 makes a scroll
25 movement while the substrate W is rotated. The electrode table 56 and the substrate W can make any movement as long as they move relative to each other. For example, one of the electrode table 56 and the substrate W may be rotated, or both of them may be rotated. In the above embodiment, the substrate holder 54 attracts and holds the substrate W in a state such that the surface of the substrate W faces downward (in a face-down manner). However, the substrate W may be held
30 in a state such that the surface of the substrate W faces upward (in a face-up manner).

Although certain preferred embodiments of the present invention have been shown and described in detail, it should be understood that various changes and

modifications may be made therein without departing from the scope of the appended claims.

Industrial Applicability

- 5 The present invention is suitable for use in an electrolytic processing apparatus for processing a conductive material formed on a surface of a substrate such as a semiconductor wafer or removing impurities attached to the surface of the substrate.

CLAIMS

1. An electrolytic processing apparatus comprising:
a feed electrode configured to feed an electric current to a conductive
5 material formed on a workpiece;
a contact member configured to be brought into contact with or close to the
workpiece;
a process electrode operable to perform an electrolytic process on the
conductive material formed on the workpiece;
10 an electrolytic processing liquid source operable to supply an electrolytic
processing liquid between the workpiece and said contact member;
a regeneration liquid chamber configured to immerse said process electrode
in a regeneration liquid;
a regeneration liquid supply source operable to supply the regeneration
15 liquid to said regeneration liquid chamber;
a regeneration electrode spaced from said process electrode;
a power supply operable to apply a voltage between said feed electrode,
said process electrode, and said regeneration electrode; and
a controller operable to control the voltage applied between said feed
20 electrode, said process electrode, and said regeneration electrode so that said feed
electrode has a potential higher than said process electrode and the same polarity as
said process electrode, and that said process electrode has a potential higher than
said regeneration electrode.
- 25 2. The electrolytic processing apparatus as recited in claim 1, further
comprising an insulation member disposed between said contact member and said
process electrode, said insulation member having liquid permeability.
- 30 3. The electrolytic processing apparatus as recited in claim 2, further
comprising a diaphragm disposed between said contact member and said insulation
member so as to separate the electrolytic processing liquid and said regeneration
liquid.

4. The electrolytic processing apparatus as recited in claim 3, wherein said diaphragm comprises an ion exchange film.

5 5. The electrolytic processing apparatus as recited in any one of claims 1 through 4, wherein said contact member comprises an ion exchanger.

6. The electrolytic processing apparatus as recited in any one of claims 1 through 5, wherein said process electrode has liquid permeability.

10 7. The electrolytic processing apparatus as recited in any one of claims 1 through 6, wherein said controller is operable to control potentials of said feed electrode, said process electrode, and said regeneration electrode, or currents flowing through said feed electrode, said process electrode, and said regeneration electrode.

15

8. The electrolytic processing apparatus as recited in claim 7, wherein said controller is operable to control the current flowing through said process electrode so as to be equal to 1 to 30 % of the current flowing through said feed electrode or said regeneration electrode.

20

FIG. 1A

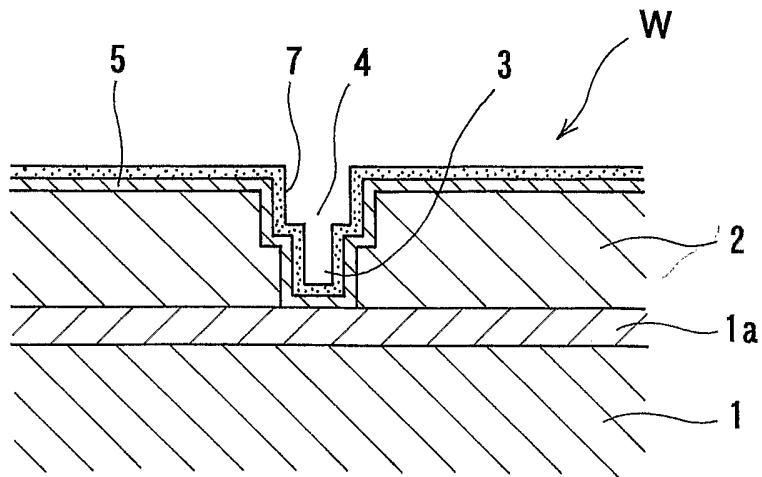

FIG. 1B

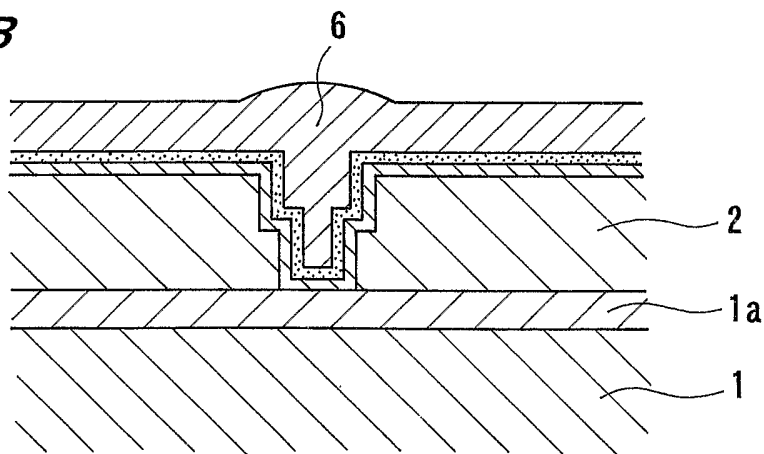

FIG. 1C

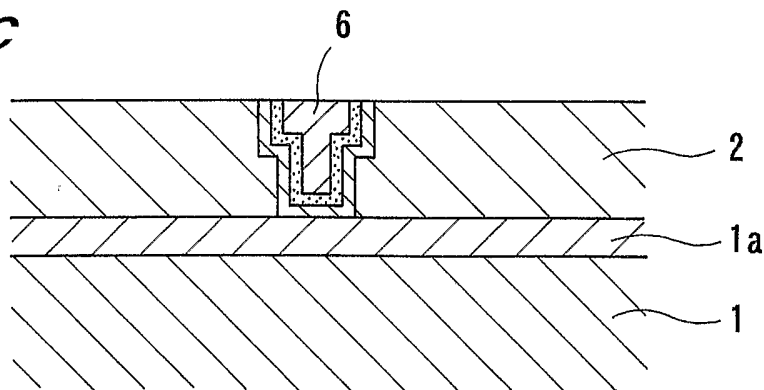

FIG. 2

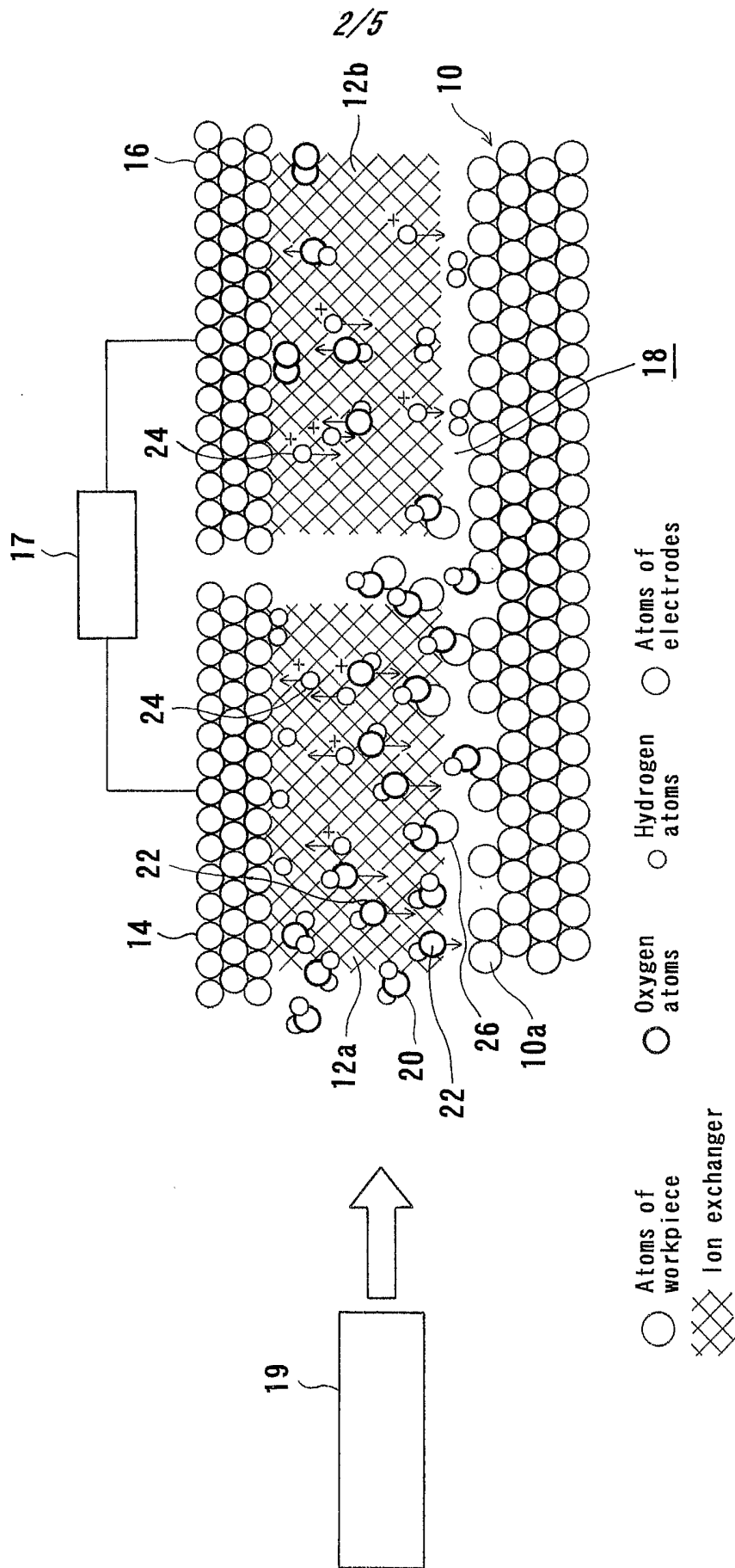

FIG. 3

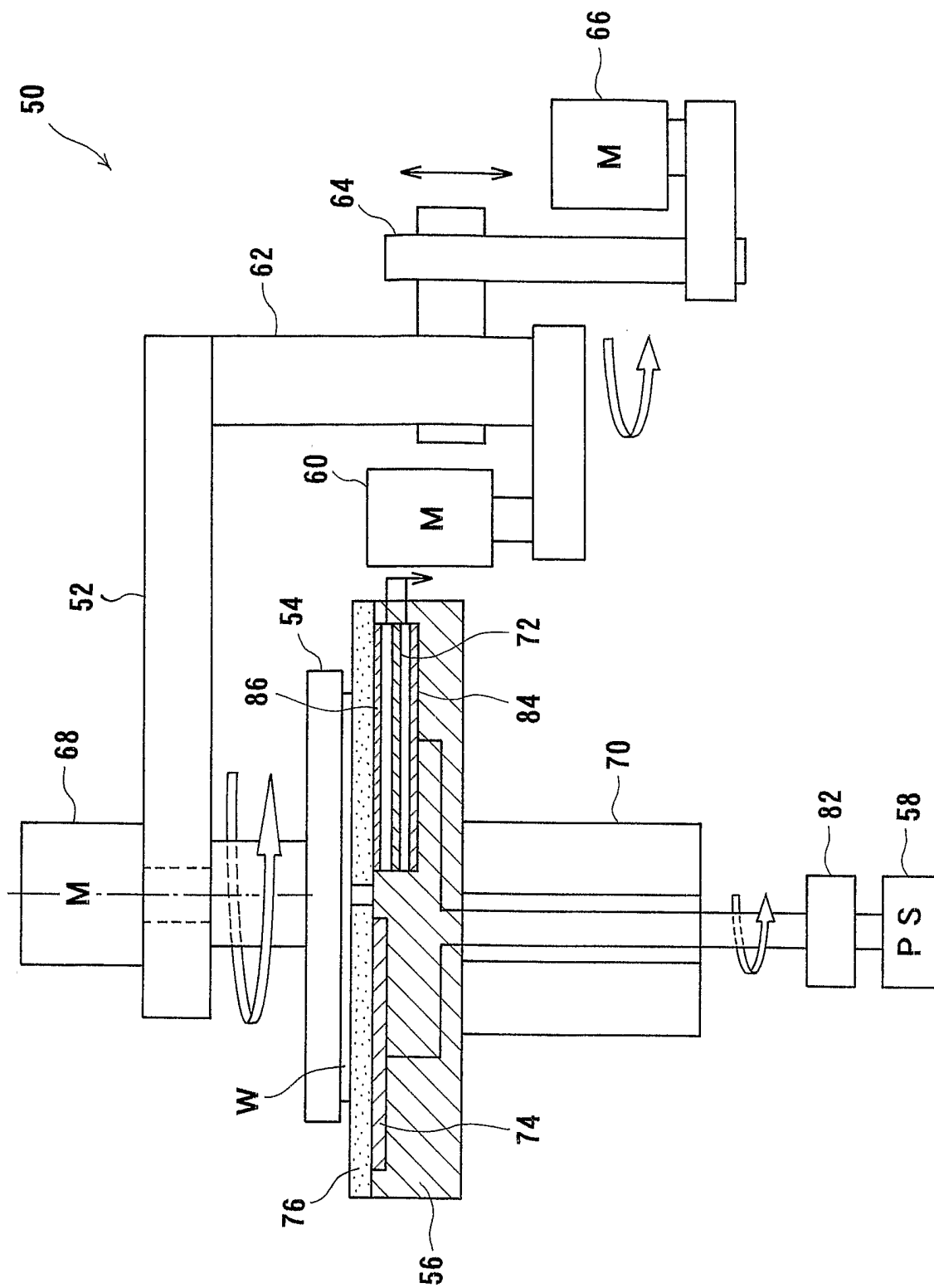

FIG. 4

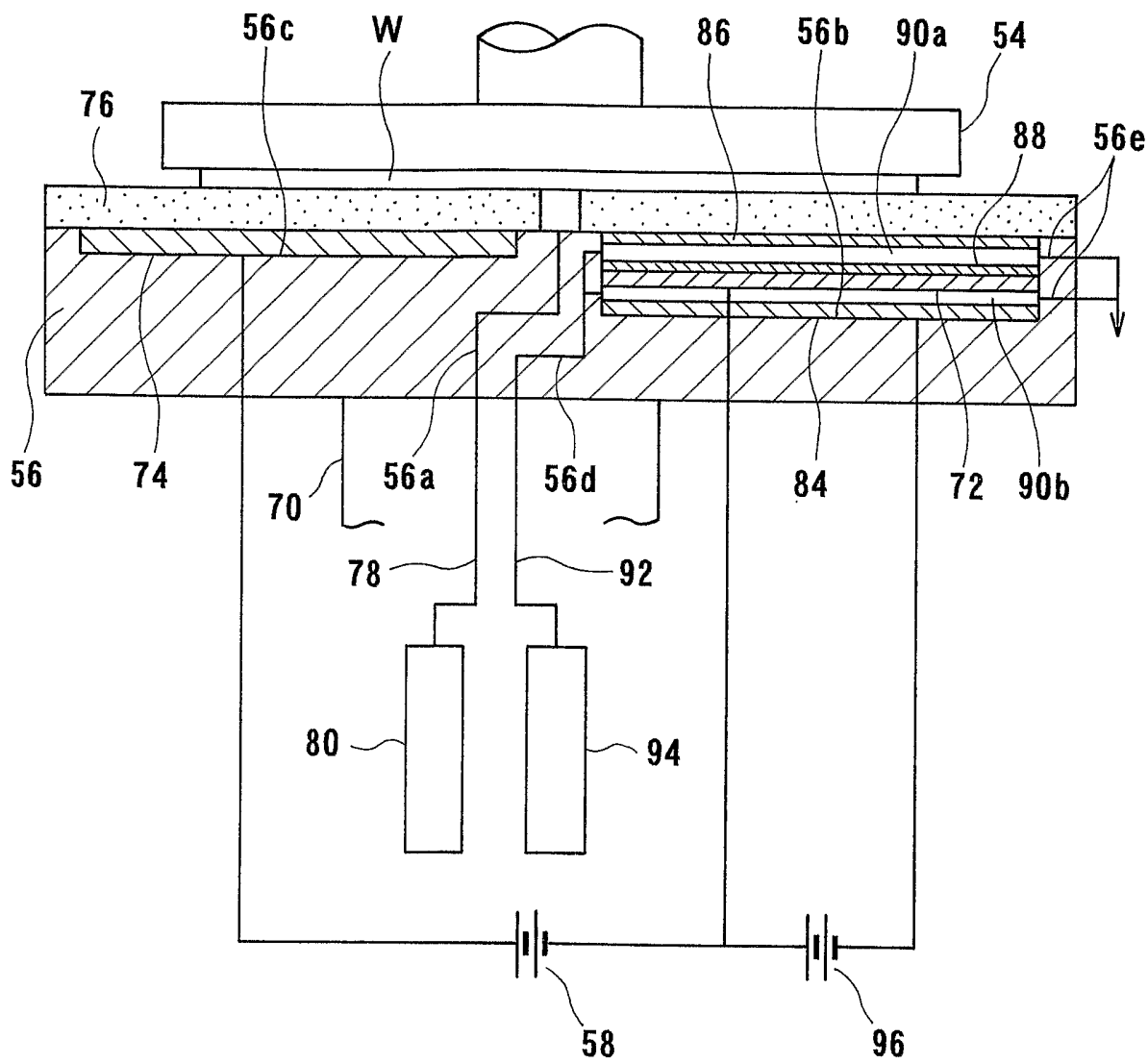

FIG. 5A

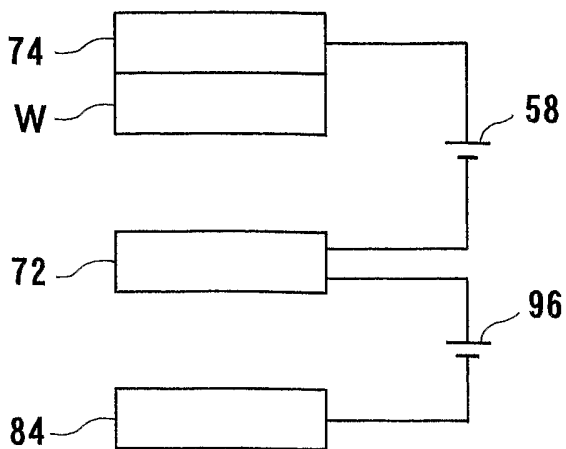

FIG. 5B

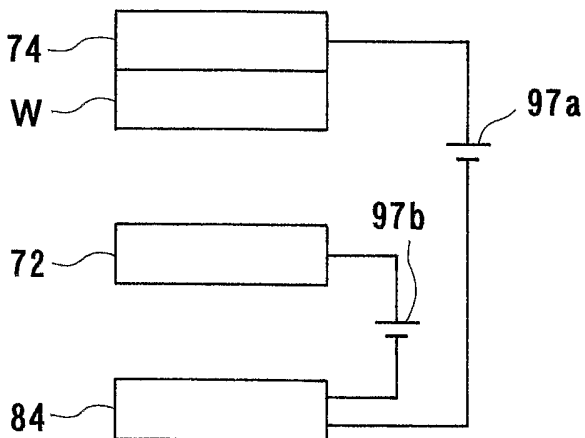
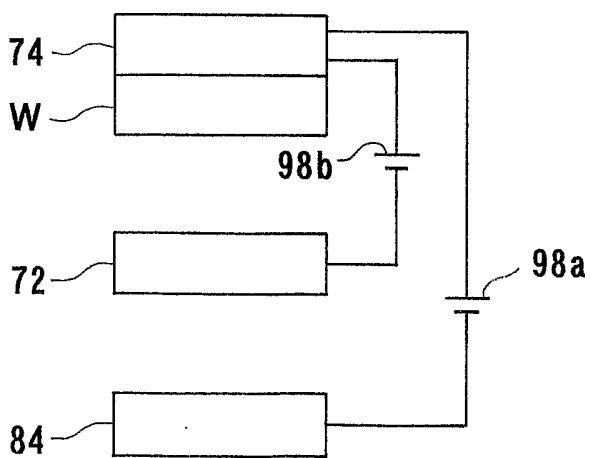

FIG. 5C



INTERNATIONALSEARCHREPORT

International application No.

PCT/JP2005/006208

A. CLASSIFICATION OF SUBJECT MATTER

Int.Cl.⁷ C25F3/00, 3/20, 3/22, 3/24, 3/26, 7/00

According to International Patent Classification (IPC) or to both national classification and IPC

B. FIELDS SEARCHED

Minimum documentation searched (classification system followed by classification symbols)

Int.Cl.⁷ C25F3/00, 3/20, 3/22, 3/24, 3/26, 7/00

Documentation searched other than minimum documentation to the extent that such documents are included in the fields searched

Published examined utility model applications of Japan 1922-1996
 Published unexamined utility model applications of Japan 1971-2005
 Registered utility model specifications of Japan 1996-2005
 Published registered utility model applications of Japan 1994-2005

Electronic data base consulted during the international search (name of data base and, where practicable, search terms used)

C. DOCUMENTS CONSIDERED TO BE RELEVANT

Category*	Citation of document, with indication, where appropriate, of the relevant passages	Relevant to claim No.
X	JP 2004-002955 A (EBARA CORPORATION) 2004.01.08, 【0085】 - 【0089】 , 【0112】 , 【 <input checked="" type="checkbox"/> 5】 , 【 <input checked="" type="checkbox"/> 6】 & WO 03/046263 A1 & US 2004/0112761 A1	1-8

 Further documents are listed in the continuation of Box C. See patent family annex.

* Special categories of cited documents:

"A" document defining the general state of the art which is not considered to be of particular relevance

"E" earlier application or patent but published on or after the international filing date

"L" document which may throw doubts on priority claim(s) or which is cited to establish the publication date of another citation or other special reason (as specified)

"O" document referring to an oral disclosure, use, exhibition or other means

"P" document published prior to the international filing date but later than the priority date claimed

"T" later document published after the international filing date or priority date and not in conflict with the application but cited to understand the principle or theory underlying the invention

"X" document of particular relevance; the claimed invention cannot be considered novel or cannot be considered to involve an inventive step when the document is taken alone

"Y" document of particular relevance; the claimed invention cannot be considered to involve an inventive step when the document is combined with one or more other such documents, such combination being obvious to a person skilled in the art

"&" document member of the same patent family

Date of the actual completion of the international search

23.06.2005

Date of mailing of the international search report

12.7.2005

Name and mailing address of the ISA/JP

Japan Patent Office

3-4-3, Kasumigaseki, Chiyoda-ku, Tokyo 100-8915, Japan

Authorized officer

KENGO KOYANAGI

Telephone No. +81-3-3581-1101 Ext. 3425

4E

3232