

(19) World Intellectual Property Organization
International Bureau



(43) International Publication Date
10 May 2007 (10.05.2007)

PCT

(10) International Publication Number
WO 2007/053789 A2

(51) International Patent Classification:
B27N 3/00 (2006.01) *B29C 47/00* (2006.01)

(74) Agents: **BROWN, Marc, E.** et al.; MCDERMOTT, WILL & EMERY, 2049 CENTURY PARK EAST, SUITE 3400, Los Angeles, CA 90067 (US).

(21) International Application Number:
PCT/US2006/043318

(81) Designated States (unless otherwise indicated, for every kind of national protection available): AE, AG, AL, AM, AT, AU, AZ, BA, BB, BG, BR, BW, BY, BZ, CA, CH, CN, CO, CR, CU, CZ, DE, DK, DM, DZ, EC, EE, EG, ES, FI, GB, GD, GE, GH, GM, GT, HN, HR, HU, ID, IL, IN, IS, JP, KE, KG, KM, KN, KP, KR, KZ, LA, LC, LK, LR, LS, LT, LU, LV, LY, MA, MD, MG, MK, MN, MW, MX, MY, MZ, NA, NG, NI, NO, NZ, OM, PG, PH, PL, PT, RO, RS, RU, SC, SD, SE, SG, SK, SL, SM, SV, SY, TJ, TM, TN, TR, TT, TZ, UA, UG, US, UZ, VC, VN, ZA, ZM, ZW.

(22) International Filing Date:
6 November 2006 (06.11.2006)

(25) Filing Language: English

(26) Publication Language: English

(30) Priority Data:
60/733,451 4 November 2005 (04.11.2005) US
11/556,027 2 November 2006 (02.11.2006) US
60/820,046 21 July 2006 (21.07.2006) US
60/864,060 2 November 2006 (02.11.2006) US
60/864,291 3 November 2006 (03.11.2006) US
60/864,293 3 November 2006 (03.11.2006) US

(84) Designated States (unless otherwise indicated, for every kind of regional protection available): ARIPO (BW, GH, GM, KE, LS, MW, MZ, NA, SD, SL, SZ, TZ, UG, ZM, ZW), Eurasian (AM, AZ, BY, KG, KZ, MD, RU, TJ, TM), European (AT, BE, BG, CH, CY, CZ, DE, DK, EE, ES, FI, FR, GB, GR, HU, IE, IS, IT, LT, LU, LV, MC, NL, PL, PT, RO, SE, SI, SK, TR), OAPI (BF, BJ, CF, CG, CI, CM, GA, GN, GQ, GW, ML, MR, NE, SN, TD, TG).

(71) Applicant (for all designated States except US): **UNIVERSITY OF SOUTHERN CALIFORNIA** [US/US]; 3716 SOUTH HOPE STREET, SUITE 313, Los Angeles, CA 90007-4344 (US).

Declaration under Rule 4.17:

— as to applicant's entitlement to apply for and be granted a patent (Rule 4.17(ii))

(72) Inventor; and

(75) Inventor/Applicant (for US only): **KHOSHNEVIS, Behrokh** [US/US]; 13900 PANAY WAY, #R212, Marina Del Rey, CA 90292 (US).

Published:

— without international search report and to be republished upon receipt of that report

[Continued on next page]

(54) Title: MATERIAL DELIVERY SYSTEM USING DECOUPLING ACCUMULATOR

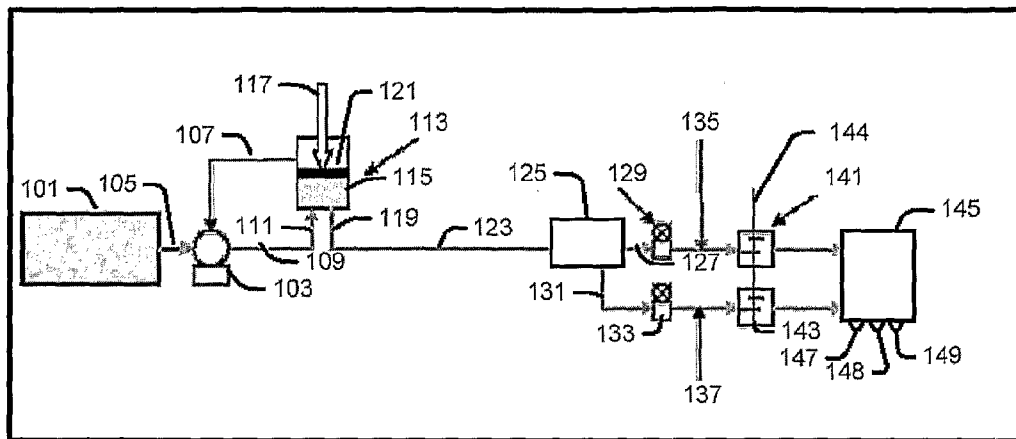

(57) Abstract: A cementitious material delivery system may include a pump configured to pump cementitious material and an accumulator. The accumulator may be a decoupling accumulator and may contain a reservoir configured to store cementitious material, an accumulator inlet to the reservoir configured to receive cementitious material pumped by the pump, an accumulator outlet configured to deliver cementitious material from the reservoir, and a pressure applicator configured to apply pressure to the cementitious material that is delivered from the accumulator outlet.

WO 2007/053789 A2



For two-letter codes and other abbreviations, refer to the "Guidance Notes on Codes and Abbreviations" appearing at the beginning of each regular issue of the PCT Gazette.

MATERIAL DELIVERY SYSTEM USING DECOUPLING ACCUMULATOR

CROSS-REFERENCE TO RELATED APPLICATIONS

[0001] This application is based upon and claims priority to U.S. Provisional Patent Application Serial Number 60/733,451, entitled "Material Delivery Approaches for Contour Crafting," filed November 4, 2005, attorney docket no. 28080-193; U.S. Patent Application Serial No. 11/556,027, entitled "Material Delivery System Using Decoupling Accumulator," filed November 2, 2006, attorney docket no. 28080-231; U.S. Provisional Patent Application Serial No. 60/820,046, entitled "Accumulated Design for Cementitious Material Delivery," filed July 21, 2006, attorney docket no. 28080-216; and U.S. Provisional Patent Application Serial No. 60/864,060 entitled "Metering and Pumping Devices," filed November 2, 2006, attorney docket no. 28080-251; U.S. Provisional Application Serial No. 60/864,291, entitled "Metering and Pumping Devices," Attorney Docket No. 28080-252, filed November 3, 2006; and U.S. Provisional Application Serial No. 60/864,293, entitled "Gantry Robotics System and Related Material Transport for Contour Crafting," Attorney Docket No. 28080-253, filed November 3, 2006. The entire content of all of these applications is incorporated herein by reference.

[0002] This application is also related to U.S. Patent Application Serial No. 10/760,963, entitled "Multi-Nozzle Assembly for Extrusion of Wall," Attorney Docket No. 28080-115, filed January 20, 2004, which claims priority to and incorporates by reference U.S. Provisional Application Serial No. 60/441,572, entitled "Automated Construction," Attorney Docket No. 28080-097, filed January 21, 2003. This application is also related to U.S. Patent Application Serial No. 11/040,401, entitled "Robotic Systems for Automated Construction," Attorney Docket No. 28080-149, filed January 21, 2005, U.S. Patent Application Serial No. 11/040,602, entitled "Automated Plumbing, Wiring, and Reinforcement," Attorney Docket No. 28080-154, filed January 21, 2005, and U.S. Patent Application Serial No. 11/040,518, entitled "Mixer-Extruder Assembly," filed January 21, 2005, Attorney Docket No. 28080-155, all three of which claim priority to U.S. Provisional Application Serial No. 60/537,756, entitled "Automated Construction Using Extrusion," Attorney Docket No. 28080-124, filed January 20, 2004. This

application is also related to the following U.S. Provisional Applications: Serial No. 60/730,560, entitled "Contour Crafting Nozzle and Features for Fabrication of Hollow Structures," Attorney Docket No. 28080-190, filed October 26, 2005; Serial No. 60/730,418, entitled "Deployable Contour Crafting Machine," Attorney Docket No. 28080-191, filed October 26, 2006; Serial No. 60/744,483, entitled "Compliant, Low Profile, Non-Protruding and Genderless Docking System for Robotic Modules," Attorney Docket No. 28080-202, filed April 7, 2006; and Serial No. 60/807,867, entitled "Lifting and Emptying System for Bagged Materials," Attorney Docket No. 28080-212, filed July 20, 2006. This application is also related to U.S. Patent Application Serial No. 11/552,741, entitled "Deployable Contour Crafting," Attorney Docket No. 28080-227, filed October 25, 2006, and U.S. Patent Application Serial No. 11/552,885, entitled "Extruded Wall with Rib-Like Interior," Attorney Docket No. 28080-229, filed October 25, 2006; and U.S. Patent Application Serial No. 11/556,048, entitled "Dry Material Transport and Extrusion," filed November 2, 2006, Attorney Docket No. 28080-246. The entire content of all of these applications is incorporated herein by reference.

BACKGROUND

FIELD

[0003] This application relates to material delivery and extrusion systems, including systems configured to deliver and extrude cementitious material.

DESCRIPTION OF RELATED ART

[0004] Structures, such as buildings, may be built up, layer by layer, by extruding cementitious or other unhardened material from a nozzle moving in a controlled pattern. Examples of apparatuses and processes that may be used are set forth in the patent applications that have been incorporated by reference in the Cross-Reference to Related Applications section of this application.

[0005] The quality of the result may depend upon being able to accurately control the rate at which the cementitious or other material is extruded from the nozzle. Controlling the pressure or rate at which the material is delivered from a remote pump, however, may not be sufficient. Intervening hoses may expand or contract and gas bubbles in the material itself may compress or expand. Changes in pressure at the output of the pump, therefore, may not be immediately reflected at the nozzle.

SUMMARY

[0006] A cementitious material delivery system may include a pump configured to pump cementitious material and an accumulator. The accumulator may be a decoupling accumulator and may contain a reservoir configured to store cementitious material, an accumulator inlet to the reservoir configured to receive cementitious material pumped by the pump, an accumulator outlet configured to deliver cementitious material from the reservoir, and a pressure applicator configured to apply pressure to the cementitious material that is delivered from the accumulator outlet.

[0007] The decoupling accumulator may be configured to pass cementitious material that sequentially enters the accumulator inlet in substantially the same sequence through the accumulator outlet.

[0008] The decoupling accumulator may include a cylinder and a piston within the cylinder.

[0009] A volume defined by the piston and the cylinder may function as the reservoir.

[0010] The decoupling accumulator may include a hollow shaft connected to the piston. The hollow shaft may have an end connected to the piston and an opposite end that functions as the accumulator inlet.

[0011] The piston may have a pushing surface and an opening within the pushing surface. The hollow shaft may be attached to the piston such that cementitious material may flow from the accumulator inlet through the opening in the pushing surface of the piston.

[0012] The cylinder may include an opening there through that is sized and positioned to allow cementitious material to escape from the cylinder only when the cylinder has been filled beyond a threshold amount.

[0013] The pressure applicator may be configured to apply a substantially constant pressure to the cementitious material.

[0014] The pressure applicator may include a pneumatic actuator.

[0015] The pressure applicator may include a bladder.

[0016] The decoupling accumulator may include a detection system configured to detect when the amount of cementitious material in the reservoir reaches a first

amount and a second amount. The pump may be configured to be activated when the detection system detects that the amount of cementitious material in the reservoir has reached the first amount and to be deactivated when the detection system detects that the amount of cementitious material in the reservoir has reached the second amount. The detection system may include a first and second level sensor.

[0017] The cementitious material delivery system may include a nozzle configured to extrude the cementitious material delivered from the accumulator outlet.

[0018] The cementitious material delivery system may include a flow divider configured to divide the cementitious material delivered from the accumulator outlet of the reservoir into a first stream of cementitious material and a second stream of cementitious material that is separate from the first stream.

[0019] The cementitious material delivery system may include a first mixer configured to mix a first chemical agent with the first stream of cementitious material and a second mixer configured to mix a second chemical agent with the second stream of cementitious material.

[0020] The first and the second chemical agents may have different compositions that cause the first and the second streams to cure at substantially different rates. Nozzle may be configured to extrude the first stream of cementitious material and the second stream of cementitious material separately from the first stream.

[0021] These, as well as other components, steps, features, objects, benefits, and advantages, will now become clear from a review of the following detailed description of illustrative embodiments, the accompanying drawings, and the claims.

BRIEF DESCRIPTION OF DRAWINGS

[0022] The drawings disclose illustrative embodiments. They do not set forth all embodiments. Other embodiments may be used in addition or instead. Details that may be apparent or that are unnecessary are also often omitted to save space or for more effective illustration. When the same numeral appears in different drawings, it is intended to refer to the same or like components or steps.

[0023] FIG. 1 illustrates a material delivery system using a decoupling accumulator.

[0024] FIG. 2 is a cross-section of a flow-through, decoupling accumulator that uses a bladder.

[0025] FIG. 3 is a cut-away view of a flow-through, decoupling accumulator that uses a piston shown in a raised position.

[0026] FIG. 4 is a cut-away view of the flow-through, decoupling accumulator in FIG. 3 with the piston in a lowered position position.

[0027] FIG. 5 illustrates the upper portion of a flow-through, decoupling accumulator of the type shown in FIGS. 3 and 4 with a detection system and overflow protection.

[0028] FIG. 6 is a cut-away underneath view of the flow-through, decoupling accumulator that in FIG. 3.

DETAILED DESCRIPTION OF ILLUSTRATIVE EMBODIMENTS

[0029] Illustrative embodiments are now discussed. Other embodiments may be used in addition or instead. Details that may be apparent or that are unnecessary are also often omitted to save space or for more effective presentation.

[0030] Fig. 1 illustrates a material delivery system using a decoupling accumulator. As shown in Fig. 1, the material delivery system may include a reservoir 101. The reservoir may contain a mixture of unhardened material, such as unhardened cementitious material. The unhardened material may be treated with one or more retardant chemicals that may cause the material to cure slowly.

[0031] The reservoir 101 may be of any type. It may be of any shape, of any size, and made from any type of material. The reservoir 101 may include an internal mixer.

[0032] Material may be pumped from the reservoir 101 by a pump 103. The pump 103 may be external to the reservoir 101, as shown in Fig. 1, or may be within the reservoir 101. When outside, a tube 105, such as a flexible hose, may be connected between the reservoir 101 and the pump 103.

[0033] The operation of the pump 103 may be controlled by a control signal that may be delivered to the pump 103 over a control channel 107 or through other

means. Under the control of the control signal, the pump may be configured to turn on, to turn off, and/or to operate at a controllable speed, flow rate or pressure.

[0034] Material that is pumped by the pump 103 may be delivered at an outlet 104 on the pump through a tube 109, such as a flexible hose, to an inlet 111 of a decoupling accumulator 113.

[0035] The decoupling accumulator 113 may include a reservoir 115, a pressure-applicator 117, and an outlet 119.

[0036] The reservoir 115 may be configured to store material that is delivered through the inlet 111 and to deliver stored material through the outlet 119. The pressure-applicator 117 may be configured to assert pressure on the material that is stored in the reservoir 115 and, in turn, the material that is delivered through the outlet 119.

[0037] The reservoir 115 may be of any type. It may be of any shape, of any size, and made from any type of material. It may include an internal mixer.

[0038] The pressure-applicator 117 may similarly be of any type. It may be of any shape, of any size, and made from any type of material.

[0039] The pressure-applicator 117 may include a piston 121 within the reservoir 115 that is configured to create a seal between the perimeter of the piston 121 and the wall of the reservoir 115. The piston 121 may be driven downwardly by any means, such as by the weight of the piston, a weight that is placed on top of the piston, a spring, by pressure from gas such as air, or by pressure from liquid such as water. The pressure-applicator may be configured to apply a constant pressure to the material in the reservoir 115, notwithstanding changes in the amount of the material within the reservoir 115.

[0040] A detection system may be employed in connection with the decoupling accumulator 113. The detection system may be configured to detect the amount of material that is within the reservoir 115 and to generate a control signal based on this amount. This control signal may be delivered to the pump 103 over the control channel 107. The detection system may be configured to deliver a control signal to the pump 103 that turns the pump on when the level of material within the reservoir 115 is below a first threshold amount, and that turns the pump 103 off when the level of material within the reservoir 115 is above a second, larger

threshold amount. One or more level-sensing switches may be used to detect the level of the material within the reservoir 115 as part of the detection system.

[0041] Material from the outlet 119 of the decoupling accumulator 113 may be channeled by a tube 123, such as a flexible hose, to a flow divider 125. The flow divider may be configured to divide the flow of material from the tube 123 into two or more separated paths. Material from a first path may be directed by a tube 127, such as a flexible hose, to a first metering device 129. Material from a second path may be directed by a tube 131, such as a flexible hose, to a second metering device 133.

[0042] The metering devices 129 and 133 may be configured to regulate the amount of material that flows through the path in which it is interposed. Examples of such metering devices and apparatuses and processes that may be employed in connection with them are set forth in US Provisional Application 60/864,060, entitled "Metering and Pumping Devices," Attorney Docket No. 28080-251, filed November 2, 2006; and U.S. Provisional Application Serial No. 60/864,291, entitled "Metering and Pumping Devices," Attorney Docket No. 28080-252, filed November 3, 2006.

[0043] A chemical agent, which may or may not be a hardening agent, may be injected in the first path of the material at a first injection point 135. Similarly, a chemical agent which may or may not be a hardening agent may be injected into the second path of material at a second injection point 137. The chemical agents that are injected into the first injection point 135 and the second injection point 137 may be different. One chemical agent may be selected to cause the material in one path to cure quickly. This quick-curing material may be extruded by a nozzle (discussed below) to quickly form two, spaced apart, outer shell walls. The other chemical agent may be selected to cause the material in another path to cure slowly and be self-leveling. The slow-curing material may be extruded by the nozzle into the space between the two, spaced apart, outer shell walls.

[0044] A mixer 141 may be used to mix the chemical agent that is injected at the first injection point 135 with the material in the first pathway. Similarly, a mixer 143 may be used to mix the chemical agent that is injected at the second injection point 137 with the material in the second pathway. The mixers may share a common drive shaft 144.

[0045] The mixed material in the first pathway and the mixed material in the second pathway may be separately delivered to a nozzle 145. The nozzle 145 may include outlets 147 and 148 from which quick-curing mixed material may be extruded to quickly create the inner and outer shell walls. The nozzle 145 may include an outlet 149 between the outlets 147 and 148 from which slow-curing mixed material may be extruded to create a self-leveling core. Examples of nozzles and processes for using them are set forth in the patent applications that are incorporated by reference in the Cross-Reference to Related Applications section of this patent application.

[0046] Although two paths and three extrusion outlets are illustrated in Fig. 1, a different number may be used instead. For example, there may be only a single path of mixed material or there may be three paths. The nozzle may have only a single outlet or it may have two or more outlets.

[0047] A computer system may be used to partially or fully automate the operation of the pump 103, the metering devices 129 and 133, the injection of curing agents at the injection points 135 and 137, the mixers 141 and 143, the movement of the nozzle 145, and/or the extrusion of materials from the nozzle 145. In the partially automated mode, the control of one or more of these devices may be done manually. In the fully automated mode, all these devices may be controlled and operated by the computer system under the control of one or more computer programs. The same computer system, or a different computer system, may also operate a gantry system that may be used to position the nozzle and/or a deployable machine that may be used to transport the nozzle, along with the gantry system, to a construction site. Examples of apparatuses and processes that may be used in association with the apparatuses and processes described in this application are set forth in the patent applications that are incorporated by reference in the Cross-Reference to Related Applications section of this patent application.

[0048] The embodiment of the decoupling accumulator 113 that is illustrated in Fig. 1 may result in some material remaining longer in the reservoir 115 than other material. For example, material at the top of the reservoir 115 may remain within the reservoir 115 longer than material at the bottom. Some material may remain within the reservoir for so long that it begins to cure.

[0049] The decoupling accumulator 113 may be configured differently to be of a flow-through type so as to pass the material that sequentially enters the accumulator inlet in substantially the same sequence through the accumulator outlet.

[0050] Fig. 2 is a cross-section of a flow-through, accumulator that uses a bladder. As shown in Fig. 2, a decoupling accumulator 201 may include a material inlet 203, a material outlet 205, a compressible tube 207, such as a rubber tube, a sealed pressure chamber 209, and a control inlet 211.

[0051] In this embodiment, the interior wall of the compressible tube 207 may serve as a reservoir. The exterior wall of the compressible tube 207, the sealed pressure chamber 209, and the control inlet 211 may serve as a pressure-applicator. The amount of pressure on the material within the compressible tube 207 may be controlled by varying the amount of gas, such as air, or fluid, such as water, that is delivered through the control inlet 211. A pressure gauge 213 may be include to indicate the pressure within the sealed pressure chamber 209 and, in turn, that is applied though the compressible tube 207 to the material within it.

[0052] A detection system may be used in connection with the decoupling accumulator 201 so as to generate an on and off control signal for the pump 103. For this purpose, one or more sensors may be used to detect the amount of material within the compressible tube 207. The sensors may sense the diameter of the compressible tube 207, the air pressure in the sealed pressure chamber 209, and/or the weight of the decoupling accumulator. One or more of these measurements may be compared to a pre-determined maximum and a pre-determined minimum. When the amount goes below the minimum, the detection system may send a control signal to the pump 103 to turn on. When the amount reaches the maximum, the detection system may send a control signal to the pump 103 to turn off.

[0053] The decoupling accumulator 201 may be used in lieu of the decoupling accumulator 113 in Fig. 1.

[0054] Fig. 3 is a cut-away view of a flow-through decoupling accumulator that uses a piston shown in a raised position. As shown in Fig. 3, a decoupling accumulator 301 may include a piston 305 having an under-side pushing surface 333 configured to snugly traverse the interior of a cylinder 307. The piston may

be driven by a hollow drive shaft 309. Pneumatic cylinders 311 and 313 may be configured to apply downward pressure on the hollow drive shaft 309 and, in turn, the piston 305 through linkages 315, 317, 319 and 321.

[0055] In operation, material from the pump 103 may be delivered to the decoupling accumulator 301 at an inlet 331 which may be the upper end of the hollow drive shaft 309. The material may flow through the hollow drive shaft 309 and through an opening in the under-side, pushing surface 333 of the piston 305. FIG. 6 is a cut-away underneath view of the flow-through, decoupling accumulator that in FIG. 3. It illustrates the opening 334 in the piston 305.

[0056] The material may fill the reservoir defined by the inner wall of the cylinder 307, the under side pushing surface 333 of the piston 305, and a rim 335 of an outlet 337. As the material fills the reservoir, the piston may rise. However, the pneumatic cylinders 311 and 313, the linkages 315, 317, 319 and 321, the hollow drive shaft 309, and the piston 305 may cooperate to function as a pressure-applicator, applying pressure to the material within the reservoir, thus urging the material out of the outlet 337.

[0057] Fig. 4 is a cut-away view of the flow-through decoupling accumulator in Fig. 3 with the piston in a lowered position. As shown in Fig. 4, the piston 305 is at the bottom of the cylinder 307.

[0058] Fig. 5 illustrates the upper portion of a flow-through decoupling accumulator of the type shown in Figs. 3 and 4 with a detection system and overflow protection. As shown in Fig. 5, the decoupling accumulator may have the same components as shown in Figs. 3 and 4, except for the addition of an overflow outlet 401 near the upper end of the cylinder 307, a cylinder-empty sense switch 403, and a cylinder-full sense switch 405.

[0059] In this embodiment, the cylinder-empty sense switch 403 may have an actuation member 407 sized and positioned to contact a lower surface 409 of the linkage 319 when the piston 305 is almost at the bottom of the cylinder 307. A control signal generated by the empty sense switch 403 may be delivered to the pump 103 and cause the pump 103 to turn on, thus pumping material which will fill the reservoir within the cylinder 307.

[0060] When the piston 305 is almost at the top of the cylinder 307, but beneath the overflow outlet 401, an actuation member 411 on the cylinder-full sense switch

405 may be actuated by an upper surface of the piston 305. A control signal generated by the cylinder-full sense switch 405 may be delivered to the pump 103 and cause the pump 103 to turn off, thus stopping the reservoir within the cylinder 307 from continuing to fill.

[0061] If for any reason (such as sensor failure) the pump fails to shut off at this point, the piston 305 may continue to rise until the level of material within the cylinder 307 rises to the level of the overflow outlet 401. At this point, the material may exit from the overflow outlet 401, thus preventing the piston 305 from separating from the cylinder 307.

[0062] The decoupling accumulator 301 may be used in lieu of the decoupling accumulator 113 shown in Fig. 1.

[0063] The components, steps, features, objects, benefits and advantages that have been discussed are merely illustrative. None of them, nor the discussions relating to them, are intended to limit the scope of protection in any way.

Numerous other embodiments are also contemplated, including embodiments that have fewer, additional, and/or different components, steps, features, objects, benefits and advantages. The components and steps may also be arranged and ordered differently.

[0064] The phrase “means for” when used in a claim embraces the corresponding structures and materials that have been described and their equivalents. Similarly, the phrase “step for” when used in a claim embraces the corresponding acts that have been described and their equivalents. The absence of these phrases means that the claim is not limited to any of the corresponding structures, materials, or acts or to their equivalents.

[0065] Nothing that has been stated or illustrated is intended to cause a dedication of any component, step, feature, object, benefit, advantage, or equivalent to the public, regardless of whether it is recited in the claims.

[0066] In short, the scope of protection is limited solely by the claims that now follow. That scope is intended to be as broad as is reasonably consistent with the language that is used in the claims and to encompass all structural and functional equivalents.

I claim:

1. A cementitious material delivery system comprising:
a pump configured to pump cementitious material; and
a decoupling accumulator containing a reservoir configured to store cementitious material, an accumulator inlet to the reservoir configured to receive cementitious material pumped by the pump, an accumulator outlet configured to deliver cementitious material from the reservoir, and a pressure applicator configured to apply pressure to the cementitious material that is delivered from the accumulator outlet.
2. The cementitious material delivery system of claim 1 wherein the decoupling accumulator is configured to pass cementitious material that sequentially enters the accumulator inlet in substantially the same sequence through the accumulator outlet.
3. The cementitious material delivery system of claim 2 wherein the decoupling accumulator includes a cylinder and a piston within the cylinder.
4. The cementitious material delivery system of claim 3 wherein a volume defined by the piston and the cylinder functions as the reservoir.
5. The cementitious material delivery system of claim 3 wherein the decoupling accumulator includes a hollow shaft connected to the piston.
6. The cementitious material delivery system of claim 5 wherein the hollow shaft has an end connected to the piston and an opposite end that functions as the accumulator inlet.
7. The cementitious material delivery system of claim 6 wherein the piston has a pushing surface and an opening within the pushing surface that has an area less than the area of the surface outlined by the pushing surface.
8. The cementitious material delivery system of claim 7 wherein the hollow shaft is attached to the piston such that cementitious material may flow from the accumulator inlet through the opening in the pushing surface of the piston.

9. The cementitious material delivery system of claim 3 wherein the cylinder includes an opening there through that is sized and positioned to allow cementitious material to escape from the cylinder only when the cylinder has been filled beyond a threshold amount.

10. The cementitious material delivery system of claim 1 wherein the pressure applicator is configured to apply a substantially constant pressure to the cementitious material.

11. The cementitious material delivery system of claim 1 wherein the pressure applicator includes a pneumatic actuator.

12. The cementitious material delivery system of claim 1 wherein the pressure applicator includes a bladder.

13. The cementitious material delivery system of claim 1 wherein the decoupling accumulator includes a detection system configured to detect when the amount of cementitious material in the reservoir reaches a first amount and a second amount.

14. The cementitious material delivery system of claim 14 wherein the pump is configured to be activated when the detection system detects that the amount of cementitious material in the reservoir has reached the first amount and to be deactivated when the detection system detects that the amount of cementitious material in the reservoir has reached the second amount.

15. The cementitious material delivery system of claim 14 wherein the detection system includes a first and second level sensor.

16. The cementitious material delivery system of claim 1 further comprising a flow divider configured to divide the cementitious material delivered from the accumulator outlet of the reservoir into a first stream of cementitious material and a second stream of cementitious material that is separate from the first stream.

17. The cementitious material delivery system of claim 17 further comprising a first mixer configured to mix a first chemical agent with the first stream of cementitious material and a second mixer configured to mix a second chemical agent with the second stream of cementitious material.

18. The cementitious material delivery system of claim 18 further comprising the first and the second chemical agents and wherein the first and the second chemical agents have different compositions that cause the first and the second streams to cure at substantially different rates.

19. The cementitious material delivery system of claim 17 further comprising a nozzle configured to extrude the first stream of cementitious material and the second stream of cementitious material separately from the first stream.

20. The cementitious material delivery system of claim 1 further comprising a nozzle configured to extrude the cementitious material delivered from the accumulator outlet.

21. A cementitious material delivery system comprising:

a pump configured to pump cementitious material and having a pump outlet configured to deliver cementitious material pumped by the pump;

an accumulator having an accumulator inlet configured to receive cementitious material, a reservoir configured to store cementitious material received at the accumulator inlet, and an accumulator outlet configured to deliver accumulated cementitious material from the reservoir;

a first tube configured to be at least part of a cementitious delivery pathway between the pump outlet and the accumulator input;

a nozzle having a nozzle inlet configured to receive cementitious material and a nozzle outlet configured to extrude cementitious material received at the nozzle inlet; and

a second tube configured to be at least part of a cementitious delivery pathway between the accumulator outlet and the nozzle input.

22. A cementitious material delivery system comprising:

a reservoir configured to store cementitious material and to deliver the cementitious material through an outlet;

a flow divider configured to divide cementitious material delivered by the outlet into a first stream of cementitious material and a second stream of cementitious material that is separate from the first stream;

a first mixer configured to mix material with the first stream of cementitious material; and

a second mixer separate from the first mixer configured to mix material with the second stream of cementitious material.

23. The cementitious material delivery system of claim 23 further comprising a nozzle configured to extrude the first stream of cementitious material and the second stream of cementitious material separate from the first stream.

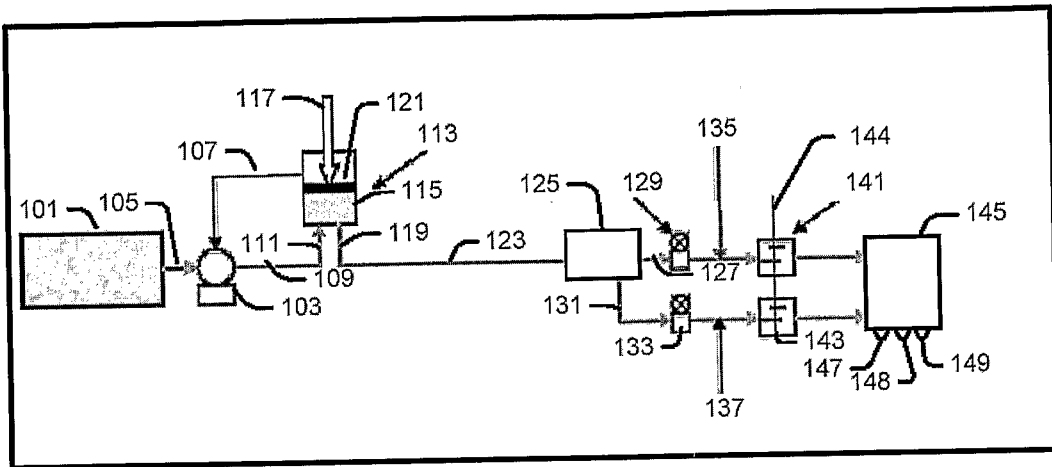

FIG. 1

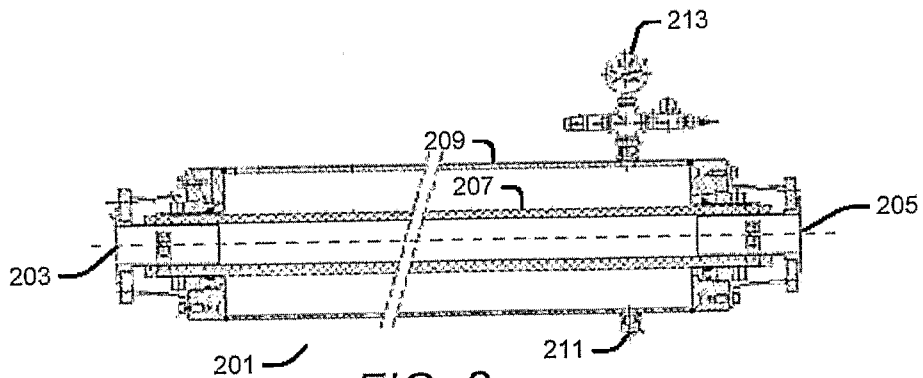

FIG. 2

2/5

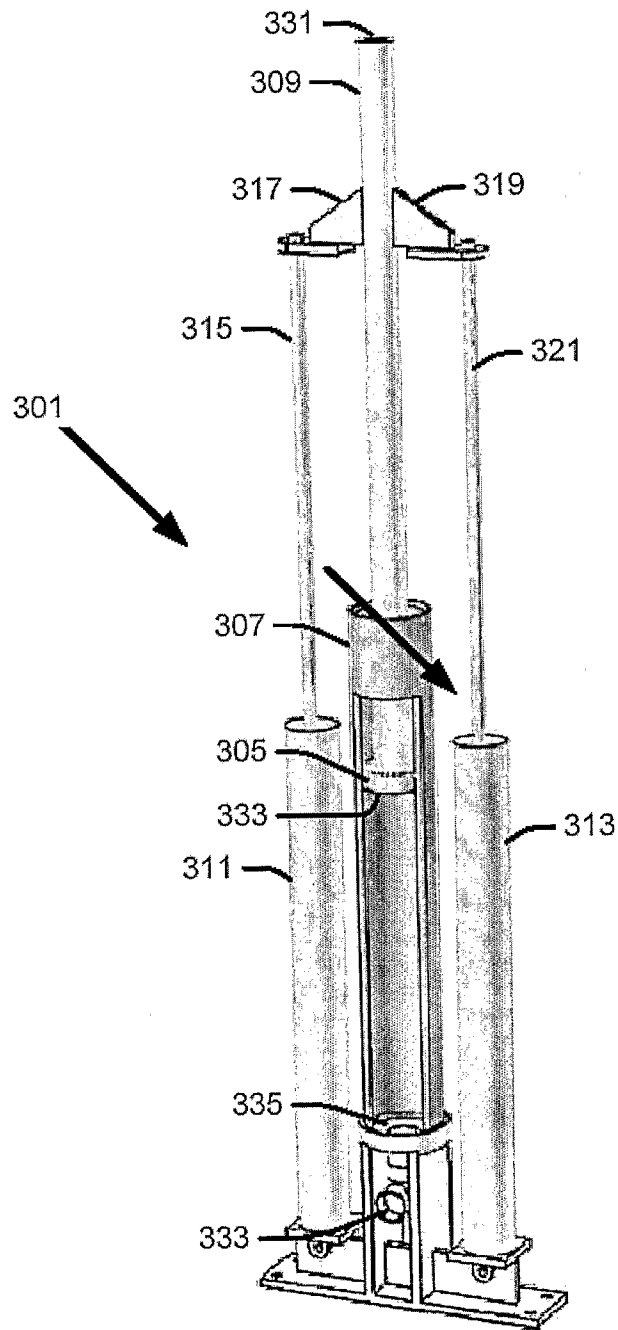

FIG. 3

3/5

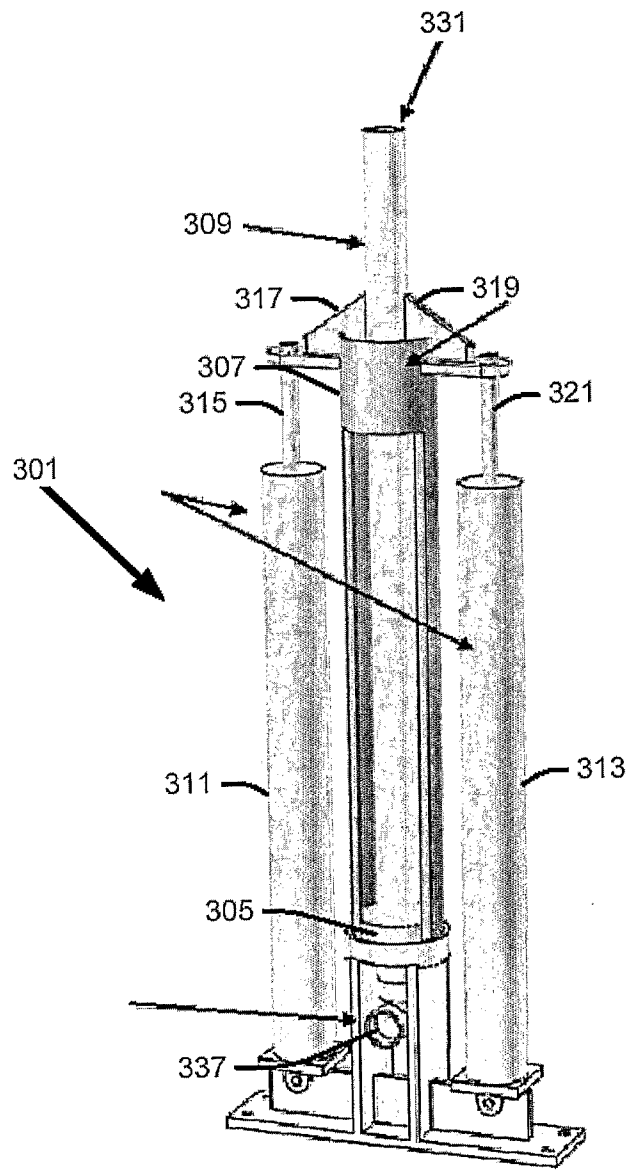

FIG. 4

4/5

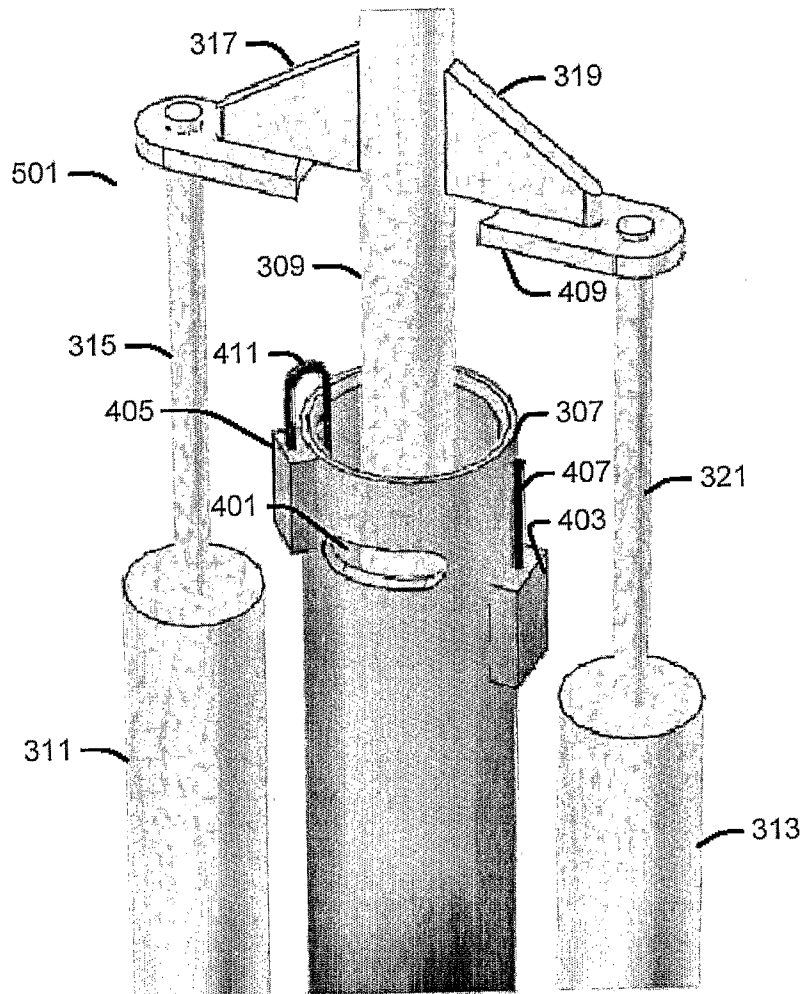

FIG. 5

5/5

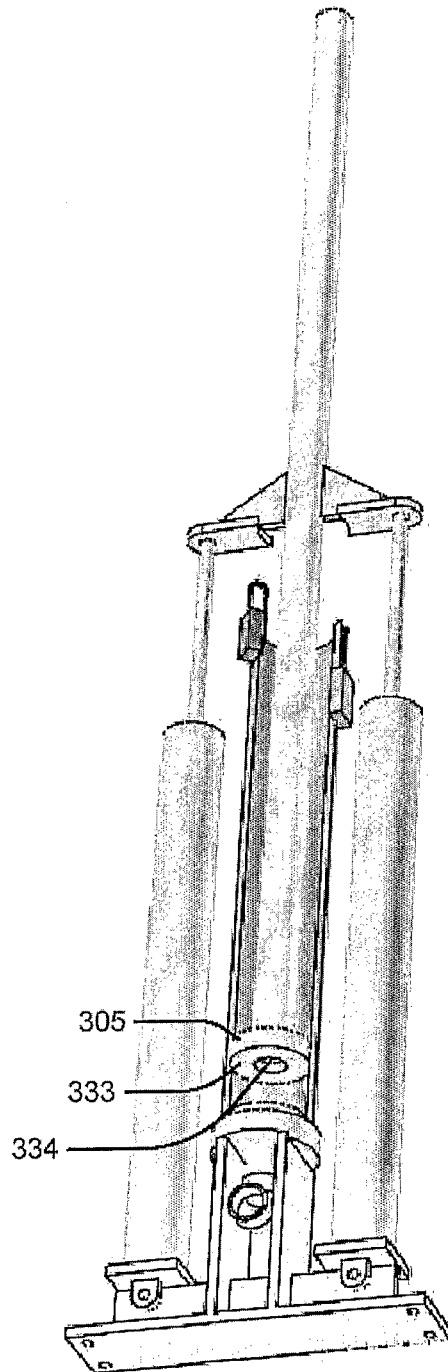

FIG. 6