

P. M. CADWELL.  
 SCOOP ATTACHING MEANS FOR GRADING AND EXCAVATING MACHINES.  
 APPLICATION FILED AUG. 5, 1920.

1,410,162.

Patented Mar. 21, 1922.

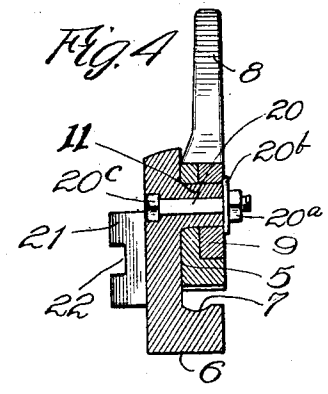
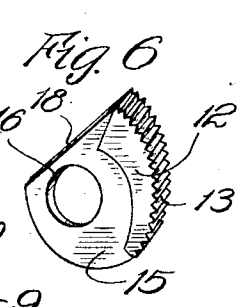
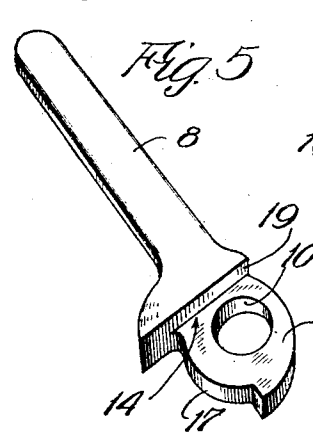
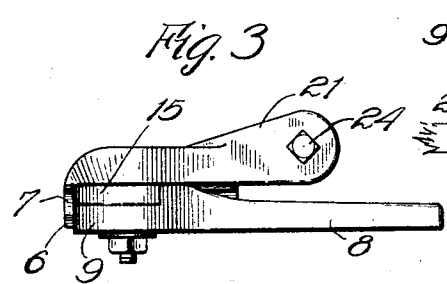
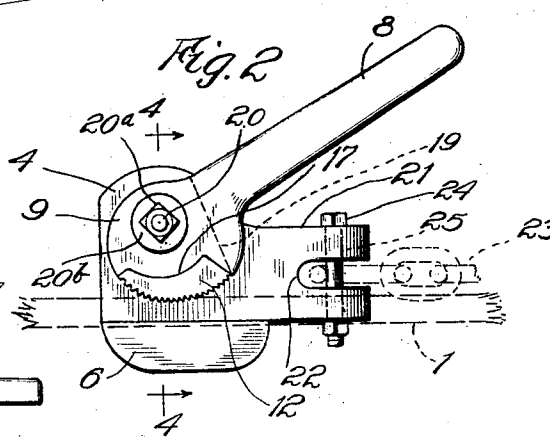
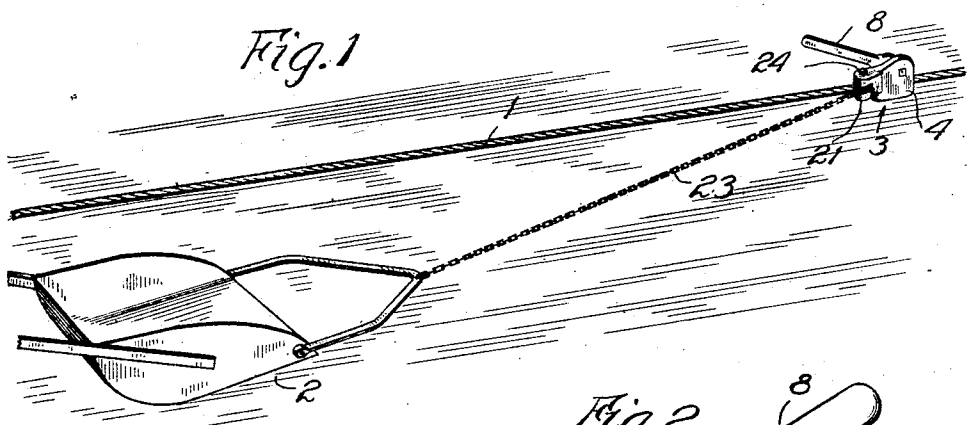

Inventor  
 P. M. Cadwell  
 By Miller Chisholm Parker  
 Attys

# UNITED STATES PATENT OFFICE.

PHINEAS M. CADWELL, OF MALVERN, IOWA, ASSIGNOR TO PHINEAS M. CADWELL AND WILLIAM H. SALYERS, DOING BUSINESS AS CADWELL & SALYERS, OF MALVERN, IOWA.

## SCOOP-ATTACHING MEANS FOR GRADING AND EXCAVATING MACHINES.

1,410,162.

Specification of Letters Patent. Patented Mar. 21, 1922.

Application filed August 5, 1920. Serial No. 401,359.

*To all whom it may concern:*

Be it known that I, PHINEAS M. CADWELL, a citizen of the United States, residing at Malvern, in the county of Mills and State of Iowa, have invented certain new and useful Improvements in Scoop-Attaching Means for Grading and Excavating Machines, of which the following is a specification.

The invention relates in general to a grading or excavating apparatus of the type disclosed in my Patent No. 1,355,938 issued October 19, 1920; and has more particular reference to a device for detachably securing the scoops of the apparatus to the actuating cable.

The object of my invention is to provide a device of the character indicated which is of a relatively simple character, is durable and is capable of effectively securing the clamps to the cable.

A further object of the invention is to provide a cable attaching device which shall present a minimum amount of resistance to the movement thereof along the surface of the earth and which is not likely to become accidentally unfastened from the cable by reason of its contact with obstructions in the path of movement of the device.

A further object of the invention is to provide a securing means which is capable of being quickly and easily operated to attach and detach the scoops from the cable.

In the accompanying drawings I have illustrated a preferred embodiment of the invention, but I recognize that various changes may be made in construction and arrangement without departing from the spirit and scope of the invention as expressed in the appended claims.

In Fig. 1 of the drawings, I have shown in perspective a scoop secured to a cable by means of a device constructed in accordance with the invention. Figs. 2 and 3 are respectively side and edge elevations of the device. Fig. 4 is a sectional view taken on line 4-4 of Fig. 2. Figs. 5 and 6 are perspective views of the operating lever and its replaceable gripping jaw, detached.

Referring first to Fig. 1, 1 designates the actuating cable of a grading or excavating apparatus such as that illustrated and described in my patent above referred to; and 2 indicates a scoop which is to be secured

to the cable by my improved securing device, designated generally by the numeral 3.

The securing device 3 comprising generally a base plate 4 of substantial length and thickness, and having a flat face 5. At the lower edge of the plate 4 there is provided a shoe 6, which is made integral with the plate and projects outwardly therefrom a substantial distance. This shoe is shaped upon its under side to provide a flat sliding surface and rounded ends; and upon its upper side the shoe has a groove 7 for receiving the cable 1.

The means for coacting with the shoe 6 to hold the cable against movement with reference thereto comprises a hand lever 8 having at its inner end a rounded enlargement or disk 9 apertured at 10 eccentrically thereof to receive a bearing stud 11. This stud is cast integral with the plate 4 and extends outwardly from the flat face 5 of the plate a distance approximately equal to the width of the shoe 6. Rigid with the rounded portion 9 of the lever is a member 12 arcuate in form and having serrated or toothed edges 13 upon its periphery adapted to engage with the cable lying in the groove 7. This member 12 may, if desired, be made separately from the lever 8 so that it may be renewed from time to time as it becomes worn in use. To this end the inner side of the enlarged portion 9 of the lever is cut away as shown at 14 (Fig. 5), and the member 12 is made rigid with a plate 15 apertured at 16 to receive the stud 11. The member 12 is made of substantially greater thickness than the plate 15, or approximately equal to the combined thickness of the portion 9 and plate 15, and the portion 9 of the lever is cut away as at 17 so as to receive the member 12. Moreover, one edge 18 of the plate 15 is adapted to engage with a shoulder 19 provided in cutting away the lever 8 to form the portion 9. The bearing stud 11 is apertured to receive a bolt 20 having a nut 20<sup>a</sup> for clamping a washer 20<sup>b</sup> upon the outer end of the stud, and thus serving to secure the hand lever upon the base plate, and at the same time secure the plate 15 with the member 12 to the portion 9 of the lever 8. Preferably the head 20<sup>c</sup> of the bolt 20 is countersunk into the adjacent face of the base plate 4. When the parts are thus operatively asso-

ciated, it will be apparent that the member 12 is made rigid with the lever 8, being held against relative movement by reason of its interfitting engagement with the cut away portion 17 of the portion 9 of the lever, and also by the engagement of the edge 18 of the plate 15 with the shoulder 19.

To provide for the attachment of the device to the scoop, the base plate has a rearwardly extending portion 21, preferably made of gradually increasing thickness (Fig. 3). This portion 21 is slotted as at 22 to receive the foremost link of the scoop chain 23, and a bolt 24 is passed through apertures 25 and across the slot for attaching the chain to the device.

The parts are so proportioned and arranged that when the cable is gripped between the shoe 6 and the member 12, the handle 8 extends in a rearward direction so that if in the travel of the cable the lever should engage with an obstruction, it will merely tend to tighten its grip on the cable rather than to be swung into its inoperative or releasing position. Moreover, the mounting of the member 12 with reference to the pivot 20 is such that the forward pull of the cable tends to move the member 12 toward the shoe 6 and hence into engagement with the cable 1.

It will be apparent that I have provided a securing device for the scoops of a grading or excavating apparatus which is of a highly practical character. The construction is relatively simple and yet is of such a rugged nature as to be very strong and durable. An important advantage is that the device is particularly adapted for travel with the cable. Thus when the device occupies its normal position in use, the shoe 6 serves to slidably support the device upon the ground, the shape of the shoe being such as to offer a minimum amount of resistance to the travel of the device with the cable. If, however, the device should assume an inverted position so that it rests on the handle 8, as it happens when the cable is raised above the ground, the handle, by reason of the fact that it extends downwardly and rearwardly, tends to move the member 12 so as to tighten its grip upon the cable. Furthermore, any obstructions engaging with the handle in its travel merely tend to tighten the grip of the device upon the cable.

It will also be seen that the shoe, in addition to its function as such, is so arranged on the plate 4 as to coact in an advantageous manner with the member 12 and lever 8 for effectively securing the cable against movement with reference to the device. When it is desired to release the device from the cable, as when the scoop has been dumped, this may be readily accomplished by the operation of the lever 8, as

may also be the attachment of the device to the oppositely traveling strand of the cable for the return of the scoop.

I claim as my invention:

1. In excavating or grading apparatus and the like, means for detachably securing an excavating scoop to an actuating cable comprising a base plate having upon one edge a portion of substantial thickness providing a shoe having a flat face upon which the base plate may slide over the ground, a lever pivoted upon the base plate adjacent said shoe and having rigid therewith a member movable toward the inner side of said shoe so as to grip a cable between it and the shoe, said plate having at its rear end a portion slotted to receive the link of a chain connected with said scoop and apertured to receive a bolt adapted to be passed through said link whereby to detachably secure the chain to the plate.

2. In a grading or excavating apparatus, means for detachably securing an excavating scoop to an actuating cable comprising a base plate having upon one edge an integral portion of substantially greater thickness than the plate proper whereby to provide a shoe having a flat underside upon which the plate may slide over the ground in use, a lever pivoted upon the base plate and having eccentrically of its pivot a rigid member movable toward the inner side of said shoe so as to grip the cable between it and the shoe, and means at the rear edge of said plate for connecting the scoop to the plate.

3. In a cable grading or excavating apparatus, means for detachably securing an excavating scoop to the actuating cable comprising a base plate having a flat face, a stud rising from said face, said plate and stud having an aperture therethrough, one edge of said plate having a portion projecting from said flat face, a lever having a rounded portion at its inner end mounted eccentrically upon said stud, a disk also mounted eccentrically on said stud having a member rigid therewith so as to be movable toward and from said projecting portion of the base plate, said disk and its member being adapted to interengage with the rounded portion of the lever whereby to be held against relative rotation, a bolt entered through said aperture in the base plate and stud for clamping the lever in position upon the base plate while maintaining the disk in operative association with the lever, and means at the rear end of the base plate for detachably securing it to the scoop.

4. A device for detachably securing a scoop of a road grading or excavating apparatus to an actuating cable comprising, in combination, a base plate of substantial length having a flat face and at one edge a fixed jaw portion protruding from said face, a bearing stud also protruding from said flat

face a distance substantially equal to the protrusion of the jaw portion, a hand lever having at its inner end a disk portion eccentrically mounted on said stud and having rigid therewith a jaw portion movable in the operation of the lever toward and from the fixed jaw portion on the base plate, a bolt entered through said stud and the base plate for securing the hand lever in operative position upon the base plate, said handle being adapted when in clamping position to extend in a rearward direction with reference to the base plate, and means at the rear end of the base plate for detachably securing the scoop thereto.

In testimony whereof, I have hereunto set my hand.

PHINEAS M. CADWELL.