

(No Model.)

5 Sheets—Sheet 1.

J. P. LUHN.
ROTARY PRINTING PRESS.

No. 521,268.

Patented June 12, 1894.

Fig. 1.

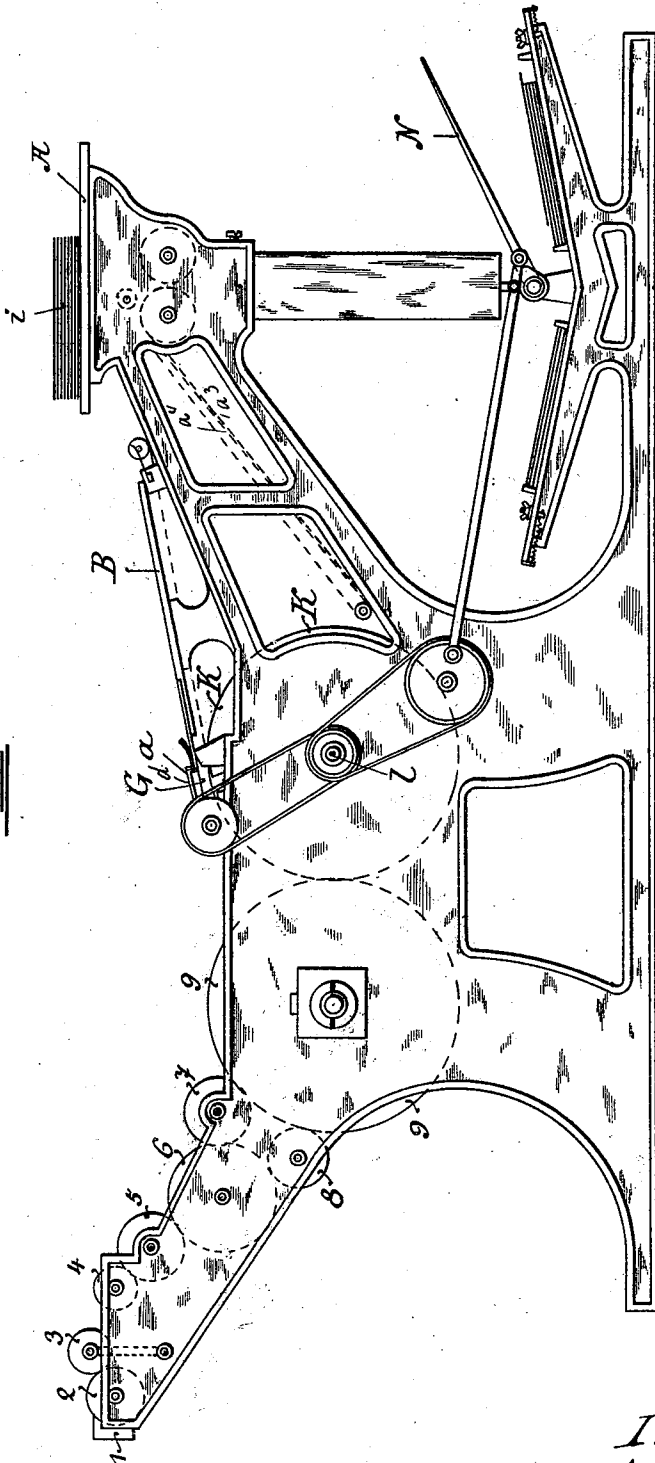

WITNESSES
H. H. Brennan
S. E. Smith

INVENTOR
J. P. Luhn
by *Gospel Paquet*
ATTORNEYS.

J. P. LUHN.
ROTARY PRINTING PRESS.

No. 521,268.

Patented June 12, 1894.

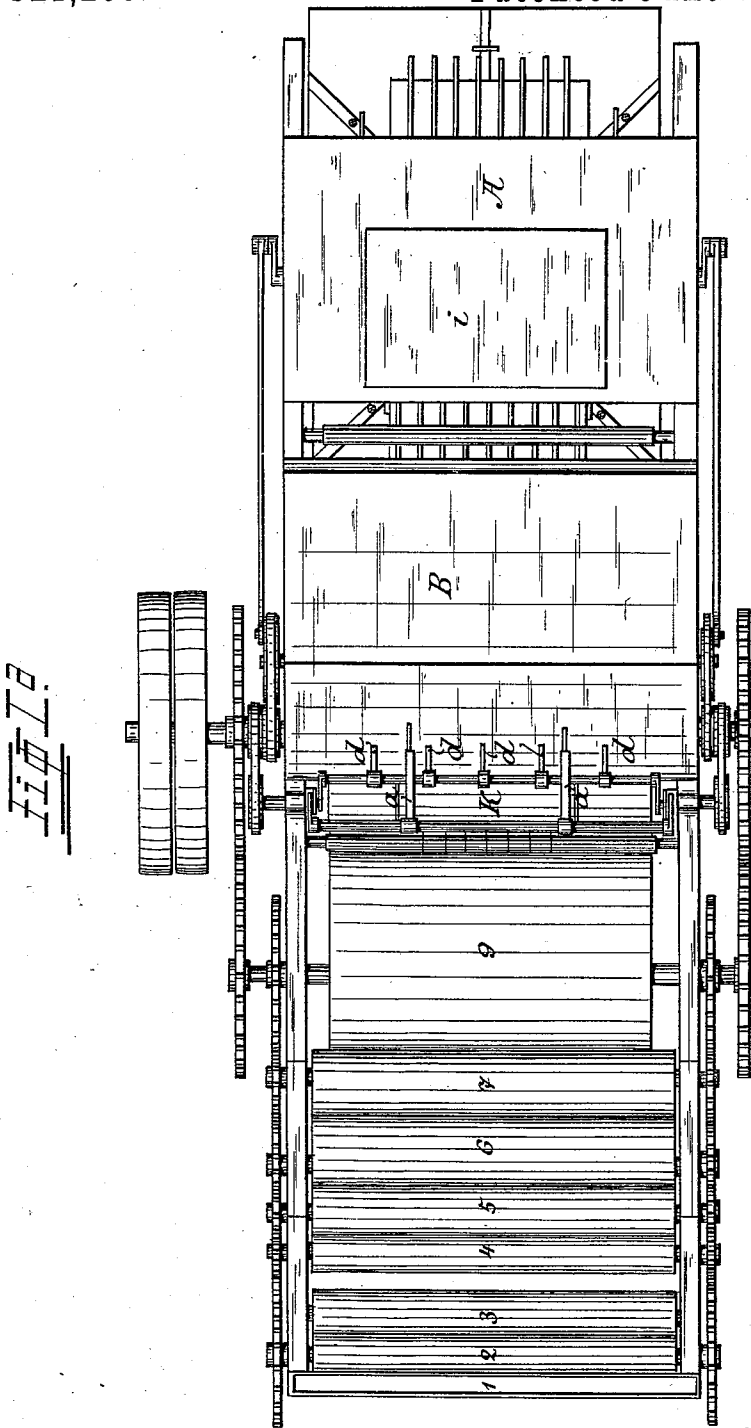

WITNESSES:
H. R. Brennan
S. E. Smith

INVENTOR.
J. P. Luhn
by *J. Gospel* Attorney
ATTORNEYS.

(No Model.)

5 Sheets—Sheet 3.

J. P. LUHN.
ROTARY PRINTING PRESS.

No. 521,268.

Patented June 12, 1894.

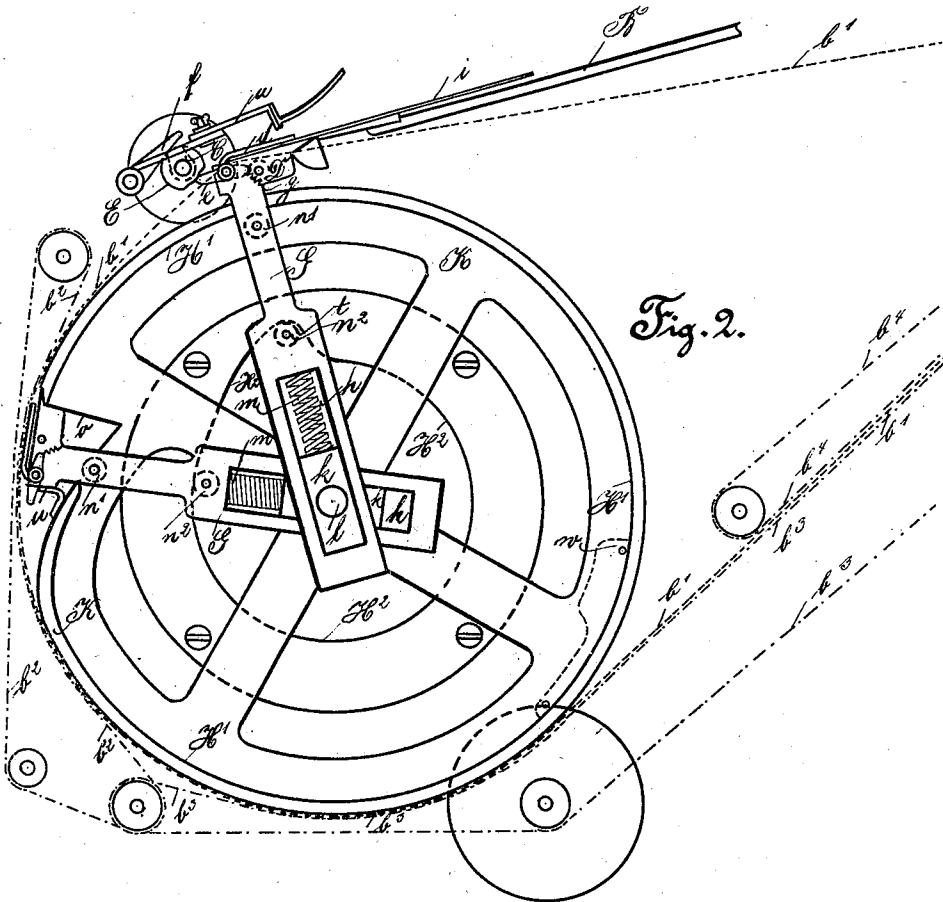

Fig. 2.

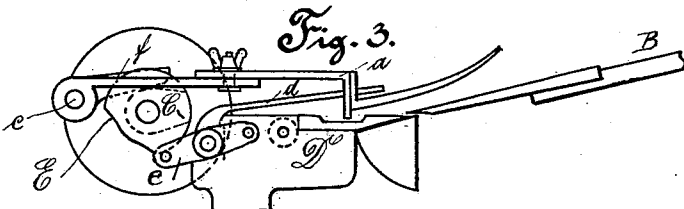

Fig. 3.

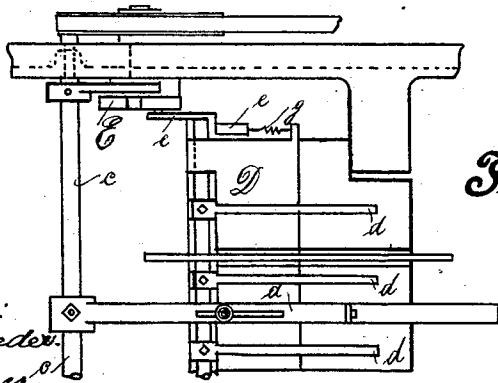

Fig. 4.

WITNESSES:
Charles Schweser,
Adolph Scherer.

INVENTOR
J. P. Luhn
by Guipel & Baegener
ATTORNEYS.

(No Model.)

5 Sheets—Sheet 4.

J. P. LUHN.
ROTARY PRINTING PRESS.

No. 521,268.

Patented June 12, 1894.

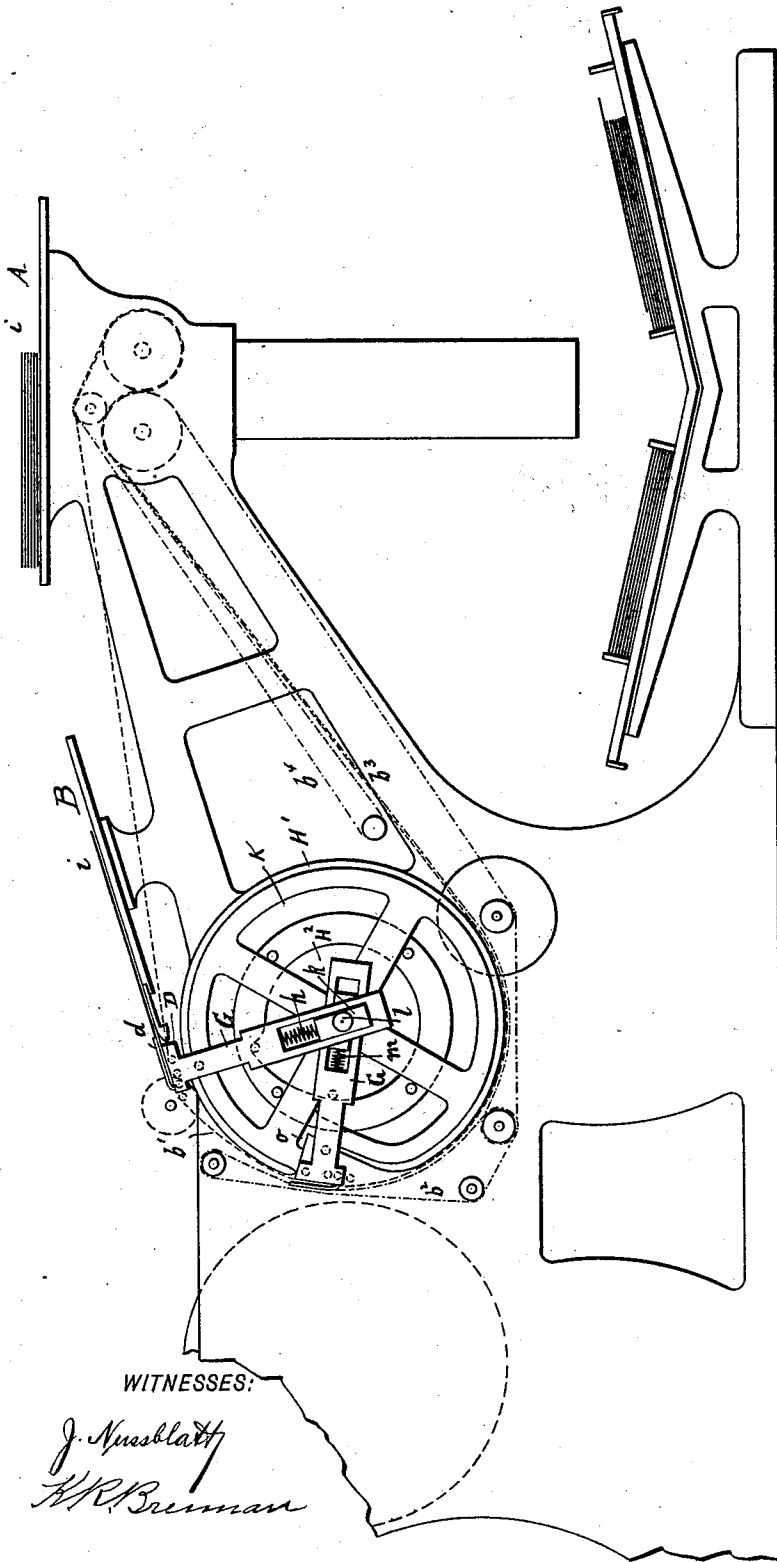

Fig. 2a.

WITNESSES:

J. Neussblatt
W. R. Brennan

INVENTOR
J. P. Luhn
BY *Georgel Rueger*

ATTORNEYS.

(No Model.)

5 Sheets—Sheet 5.

J. P. LUHN.
ROTARY PRINTING PRESS.

No. 521,268.

Patented June 12, 1894.

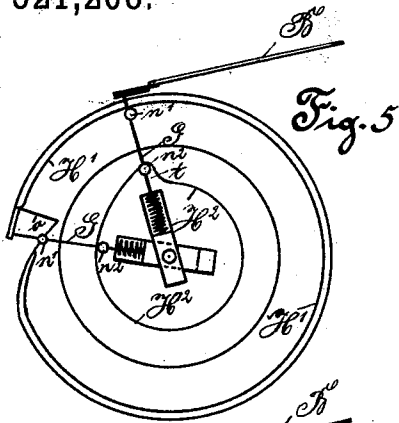

Fig. 5.

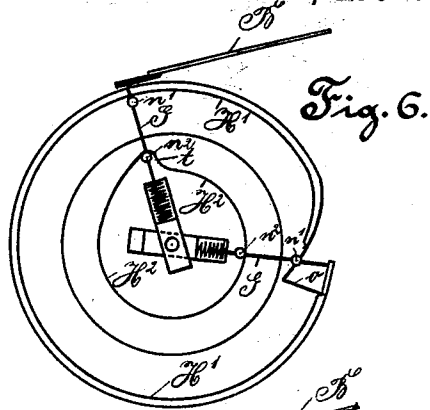

Fig. 6.

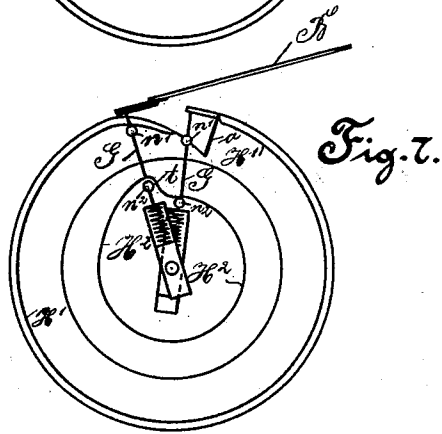

Fig. 7.

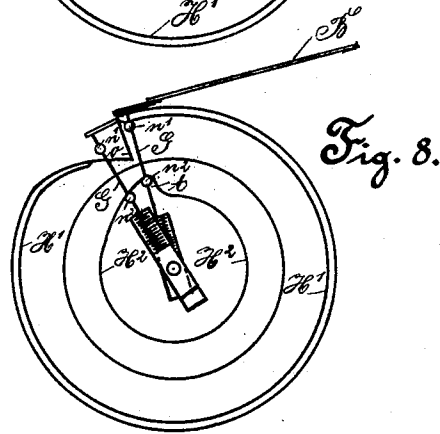

Fig. 8.

WITNESSES:
Charles Schroeder
Adolph Scherer

INVENTOR.
J. P. Luhn
By Gospel & Raquet
ATTORNEYS.

UNITED STATES PATENT OFFICE.

JOHANN PETER LUHN, OF LEIPSIC, GERMANY.

ROTARY PRINTING-PRESS.

SPECIFICATION forming part of Letters Patent No. 521,268, dated June 12, 1894.

Application filed June 7, 1893. Serial No. 476,879. (No model.)

To all whom it may concern:

Be it known that I, JOHANN PETER LUHN, a subject of the King of Prussia, and a resident of the city of Leipsic, in the Kingdom of Saxony, Germany, have invented certain new and useful Improvements in Rotary Printing-Presses, of which the following is a specification.

This invention relates to improvements in rotary printing-presses having a constantly rotating impression cylinder, into which press the sheets are fed in the ordinary manner.

The invention consists in a printing-press having a rotary impression cylinder provided with a longitudinal recess in its circumference, two gripper bars provided with grippers and mounted to move into and out of said recess, to grip a sheet, carry the same around until it is printed and then to release it.

The invention also consists in the construction and combination of parts and details as will be fully described hereinafter and finally pointed out in the claims.

In the accompanying drawings, Figure 1 is a side view of a printing press provided with my improvements. Fig. 1^a is a plan view of the same. Fig. 2^a is a side view of parts of the press, one of the side walls being removed to show the end of the impression cylinder. Fig. 2 is an enlarged detail end view of the impression cylinder. Fig. 3 is a detail side view of the gripper. Fig. 4 is a plan-view of the same. Figs. 5, 6, 7 and 8 are diagram views showing the various positions of the parts.

Similar letters and numerals of reference indicate corresponding parts.

In the drawings, 1 is the ink fountain of a printing press, 2 the doctor roller, 3 the ink conveyer roller, 4, 5, and 6 ink-spreading rollers, 7 and 8 the ink delivery rollers and 9 is the type cylinder.

K is the impression cylinder on the circumference of which the sheet to be printed is held by suitable grippers. The pile of sheets is upon the table A from which the sheets are shoved upon the inclined feed-table B until they rest against the bottom stops *a*. The impression cylinder shown at a larger scale in Fig. 2^a is fixed on its shaft *l* which is journaled in the press frame.

The gripping device consists of a bar D,

supporting the grippers *d*, and secured to arms G that are mounted to turn on the cylinder shaft *l*. Said arms are provided with longitudinal slots *h* in which the sliding blocks *k* are mounted, through which blocks the shaft *l* passes, thus permitting said arms to move radially. Springs *m* located in the slots *h* and bearing on ends of the same and against the sliding blocks *k* tend to press the arms G in the direction from the shaft *l* toward the circumference of the cylinder. The arms G are provided with two anti-friction rollers *n'* and *n''* that run in the cam tracks H' and H'', of which the track H' is formed on the end of the impression cylinder and rotates with the same, whereas the track H'' is fixed to the press frame. The track H'' is provided with a recess *t* corresponding to the positions of the arms G for gripping the sheet. The grippers *d* are raised by means of the cam E that acts on the arm *e* of the rocking shaft carrying the grippers, and a spring *g* swings down the grippers, as soon as the cam E permits of this, said spring acting on an arm of the rocking gripper-shaft.

The stops *a* previously mentioned are supported by arms of a rocking-shaft *c*. As soon as the grippers have gripped the sheet, the said stops *a* are raised by the action of the cam C, shown in dotted lines in Fig. 3, on the arm *f* of the shaft *c*.

In case the gripping device is to rotate with the impression cylinder, the arms G must be drawn inward until the gripper-bar D has passed into the recess or offset of the cylinder so that the shoulder *o* can act on the gripper-bar D and carry the same along.

For the purpose of moving the gripper-bar D inward, the end of the track H' is curved inward so as to press the rollers *n'* inward, that is toward the center of the cylinder.

The operation is as follows: When one gripper-bar is in its highest position, the grippers are directly in front of the feeding-table B. By means of the cam E the grippers are raised, so that the pressman can push a sheet against the stops *a* which are now in their lowest position. The grippers then close, the stops *a* are raised, and the gripper-bar D can carry the sheet along. This gripper-bar remains in a position of rest for the time being, as the spring *m* presses the corresponding

arm G outward and its roller n^2 into that part of the recess t that is the greatest distance from the central shaft. The other gripper bar has in the meantime been carried along by the shoulder o of the impression-cylinder and the sheet previously inserted is thus carried around by the cylinder and printed, the tapes b^1 and b^2 serving to hold the sheet snugly against the cylinder, as shown in Fig. 2.

When the impression-cylinder has completed about three fourths of its rotation (Fig. 5), a pin on the arm e strikes against a fixed cam-piece w , whereby the grippers are opened and the printed sheet released, and is then carried by the tapes b^3 and b^4 to the delivery rack N. The first mentioned gripper-bar is still in a position of rest and remains so as long as the roller n^1 rests against the concentric part of the track H' as the pressure of the spring m is sufficient to hold the roller n^2 in the recess t . As soon as the cam or eccentric part of the rotating track H' arrives at the roller n^1 , the arm G of this first mentioned gripper-bar is gradually forced inward toward the central shaft and the roller n^2 is forced out of the recess t , which recess t is so arranged in relation to the eccentric or cam-part of the track H' that the gripper-bar D while being moved inward under the action of the eccentric part of the track H' on the roller n^1 , is also moved forward slightly and is thus started with an accelerating movement until said gripper bar is engaged by the shoulder o of the impression-cylinder. The roller n^2 of one arm G passes out of the recess t a short time before the roller n^2 of the other arm passes into this recess t as appears clearly in Figs. 7 and 8. As the track H' is fixed and the track H' rotates with the impression-cylinder, the above movements can easily be obtained by shaping the tracks in the proper manner. While one gripper-bar is at rest, the second is being carried around by the cylinder and a short time before the second gripper-bar arrives at the first one, this first one is moved forward and toward the rim of the cylinder and at the same time the second gripper bar moves outward until its roller n^2 is in the recess t and the first gripper has been moved inward in front of the shoulder o to be carried around by the cylinder.

For the purpose of pressing the gripper-bar

firmly against the shoulder o of the impression cylinder, the cylinder is provided with springs u which rest against the bar D and press the same against the shoulder.

Having thus described my invention, I claim as new and desire to secure by Letters Patent—

1. A rotary printing-press constructed with a rotary impression cylinder having a recess in its circumference parallel with the axis of the cylinder, two gripper-bars mounted to move to and from the circumference of the cylinder and into and out of said recess, grippers in said bars, two sets of arms to which said gripper-bars are attached, and cam-tracks for moving said arms radially, means for supplying the type with ink, substantially as set forth.

2. A rotary printing-press constructed with a rotary impression cylinder, having a recess in its circumference parallel with the axis of the cylinder, two gripper-bars mounted to move in and out of said recess, which gripper-bars are parallel with the axis of the cylinder, and are provided with grippers, two sets of slotted arms to which the gripper-bars are fastened, slides mounted on the shaft of the cylinder and located within slots in the arms, springs interposed between the slides and the ends of the slots in said arms, means for holding the type and means for providing the type with ink, substantially as set forth.

3. A rotary printing-press constructed with a rotary impression cylinder, having a recess in its circumference parallel with the axis of the cylinder, two independent gripper-bars parallel with the axis of the cylinder and both independent of said cylinder, means for moving said gripper-bars into and out of said longitudinal recess of the cylinder, grippers on said bars, a movable stop adjacent to the grippers, and a means for raising and lowering the grippers and said movable stop, means for holding the type and means for providing the same with ink, substantially as set forth.

In testimony whereof I have signed my name to this specification in the presence of two subscribing witnesses.

JOHANN PETER LUHN.

Witnesses:

CARL BORNGRAEBER,
ADOLF HESS.