

Jan. 6, 1925.

1,521,920

J. A. WILLIAMS ET AL

IMPULSE STARTER LOCK

Filed Aug. 28, 1920

Fig. 1.

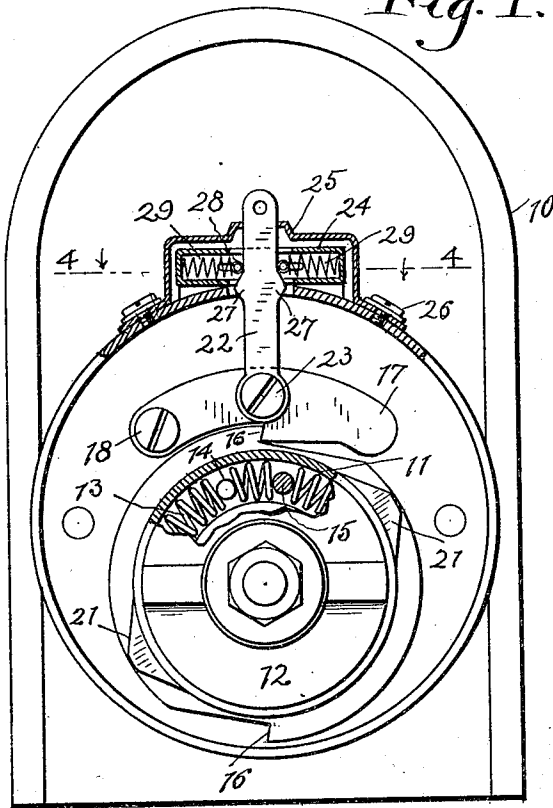

Fig. 2.

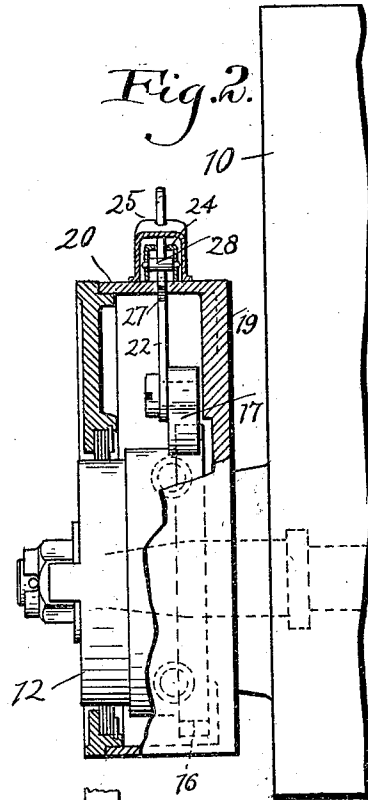
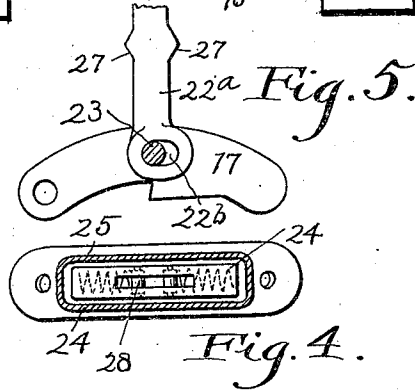
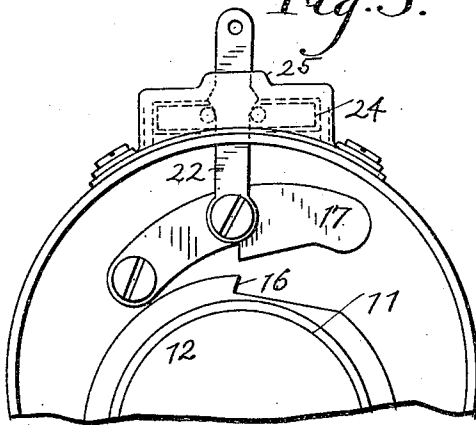

Fig. 3.



Inventors.
J. A. Williams
A. G. Karkan
by Thurston Kwis & Hudson Att'ys

UNITED STATES PATENT OFFICE.

JOSEPH A. WILLIAMS AND ALBERT G. KARKAU, OF CLEVELAND, OHIO, ASSIGNORS TO
THE K-W IGNITION COMPANY, OF CLEVELAND, OHIO, A CORPORATION OF OHIO.

IMPULSE-STARTER LOCK.

Application filed August 28, 1920. Serial No. 406,588.

To all whom it may concern:

Be it known that we, JOSEPH A. WILLIAMS and ALBERT G. KARKAU, citizens of the United States, and residents, respectively, of Cleveland, in the county of Cuyahoga and State of Ohio, and Cleveland, in the county of Cuyahoga and State of Ohio, have invented a certain new and useful Improvement in Impulse-Starters, of which the following is a full, clear, and exact description.

This invention relates to impulse starters for magnetos, and especially to an improved form of lock for the impulse starter catch.

Impulse starters commonly in use at the present time employ a pivoted catch which during normal operation is held in inoperative position, but for starting purposes is dropped inward to a position such that it may engage a shoulder on a member connected to the magneto rotor so as to hold the rotor against movement while the driving shaft is being turned through a portion of a revolution, after which a cam which turns with the drive shaft knocks the catch out of engagement with the shoulder so as to permit a spring to give the magneto armature a quick forward impulse so as to create a spark for starting purposes.

It is customary also to provide a lock for the catch, the function of which is to hold the catch in inoperative position during normal operation. Frequently this lock is in the form of a pivoted finger so disposed that when the catch is thrown outwardly with predetermined force by the cam, a pointed or undercut part of the catch will snap over a pointed or tapered nose of the locking finger and the latter will then normally prevent its return to operative position until it is manually actuated so as to release the catch.

While the form of lock above explained generally gives very good results, it has the objection that it is possible that the catch will not fully engage the locking finger, in which event, due to vibration it may fall into engagement with the rapidly rotating shouldered part of the impulse starter beneath it, in which event breakage will occur. Furthermore, in an impulse starter having a lock of this type, the catch falls by gravity when it is manually released, and at times it may not drop to operative position

especially if the bearings of the catch should have a film of oil causing a sticking tendency.

The principal object of the present invention is to provide a lock which acts positively to hold the catch either in operative or in inoperative position, and which cannot possibly hold it in an intermediate position from which it may be moved by vibration in either direction; that is to say, it is the principal object of the invention to provide a lock of a nature such that when the catch is thrown outward by the cam on the rotating part of the impulse starter it cannot be stopped and held in a position such that it can accidentally drop back to operative or working position.

Still further the invention aims to provide a lock of such a nature that access can be had to it from the outside of the housing to positively move the catch either to operative or inoperative position.

The invention may be briefly summarized as consisting in certain novel details of construction, and combinations and arrangements of parts which will be described in the specification and set forth in the appended claims.

In the accompanying sheet of drawings, Fig. 1 is a face view of an impulse starter embodying our improvement, the cover of the starter housing being removed and certain parts being in section; Fig. 2 is a vertical sectional view of the same, both Figs. 1 and 2 showing conventionally a portion of the magneto with which the starter is adapted to be associated; Fig. 3 is a view similar to Fig. 1, but showing only a portion of the impulse starter with the catch held in inoperative position; Fig. 4 is a sectional view substantially along the line 4-4 of Fig. 1, looking in the direction indicated by the arrows; and Fig. 5 shows the catch and locking bar in a slightly modified form.

Any suitable magneto may be employed with the impulse starter, the magneto being indicated at 10 in Figs. 1 and 2. Likewise the impulse starter with the exception of the catch lock may have any suitable construction, but in this case it is of the type illustrated in the Karkau Patent No. 1,264,086, granted April 23, 1918, that is to say, the impulse starter includes an inner part 11 which is fixed to the magneto shaft, and

an outer part 12 adapted to be coupled to the magneto drive shaft, and normally adapted to drive the inner part, and hence the magneto rotor through a coil spring 13 which is enclosed within one of the parts, and the ends of which are engaged by studs 14 and 15 on the two parts 11 and 12 respectively. The inner part 11 has shoulders 16 which are diametrically opposite each other, which shoulders are adapted to be engaged by a catch 17, pivoted at 18 on a base 19 of the housing 20 of the impulse starter. When the catch engages one of the shoulders the magneto rotor is held against movement while the drive shaft is turning, causing compression of the spring 13 and when the catch 17 is knocked out of engagement with the shoulder 16 by one of two cams 21 on the outer part 12, the spring 13 gives the rotor a forward impulse sufficient to cause a spark which will ignite the mixture in the engine.

In accordance with the present invention we employ an endwise movable locking bar 22 which at its lower end is pivotally connected to the catch about midway between its ends as shown at 23, and extends upwardly through a slot at the top of the housing 20 and through a so-called spring holder 24 and a spring housing 25 which is secured by screws or equivalent means 26 to the top of the main housing 20.

On opposite edges of the locking bar 22 are two V-shaped protuberances 27, the lower sides of these protuberances being inclined inwardly more abruptly than the upper sides, and in the spring holder 24 are two small rollers 28 which are pressed inwardly in a yielding manner against opposite edges of the locking bar 22, by coil springs 29 which are between the rollers and the ends of the spring holder 24.

It will be seen, therefore, that the construction is such that if the catch 17 is knocked out of engagement with the shoulder 16 with only moderate force, as when the engine is being cranked, the V-shaped protuberances will by their engagement with the rollers 28 elevate the spring holder 24 and will partially spread the rollers, in which event the catch will again drop back into engagement with the shouldered part of the impulse starter, so that the spark producing action will be repeated as desired, but when the engine starts, the catch will be thrown outwardly with sufficient force to cause the points or widest parts of the V-shaped protuberances 27 to pass the rollers 28, in which event the rollers then snap inward under the protuberances 27 and effectively hold the bar 22 and the catch 17 in inoperative position, illustrated in Fig. 3, and no amount of vibration can release the catch. In fact, the catch is securely held in inoperative position until the bar is

manually pushed downward and the points of the V-shaped protuberances pass the rollers 28.

With this construction it is virtually impossible for the catch to be held in what may be termed the half-way position as has been possible with prior constructions as already stated, but should the upward movement of the locking bar by any chance stop with the rollers engaging the points of the protuberances 27, it would immediately be jarred loose from the shoulders when the spring holder 24 drops back onto the housing so as to permit the catch to reengage the shoulder part of the impulse starter before it has acquired any speed. It is for that reason that the spring holder is mounted in the spring housing so that this small amount of lost motion is obtained. However, we do not regard this feature as essential, for the locking device is sufficiently positive and certain in its action for all practical purposes with the spring holder fixed in position with reference to the housing.

The advantage of having the locking bar and catch pushed downward by the action of the springs as the rollers ride down the upper inclined faces of the V-shaped protuberances, is that the possibility of the catch sticking as by a film of oil, is entirely overcome. In other words, the positive actuation by the springs of the catch to operative position is more reliable than is the case if gravity alone is relied on for this purpose.

In Fig. 1 an ordinary pivotal connection is provided between the locking bar and the catch, but we may, if desired, provide a pin and slot connection between the locking bar and catch as illustrated in Fig. 5, the bar here illustrated, designated 22^a, having at its lower end a slightly elongated slot 22^b instead of a round hole for the connecting pin 23. With this construction the locking bar will maintain an absolute vertical position in the movement of the catch from its uppermost to its lowermost positions. This feature, however, is not essential, for a sufficiently effective holding action is obtained by the protuberances 27 and rollers 28 with a straight pivotal connection such as utilized in Fig. 1, even though this causes a slight tilting of the locking bar.

In the drawings we have illustrated the preferred construction wherein an endwise movable locking bar or finger is held positively in either its operative or inoperative position, and wherein the catch is positively moved to operative position instead of permitted to drop to that position by gravity, but we do not desire to be confined to the construction shown, for the latter can be modified in many different ways without deviating from the invention, as, for example, by the substitution of a single

protuberance and a single holding roller for the two protuberances and two rollers herein illustrated, or by modifying the construction by the use of a roller or other equivalent
 5 detent to engage in notches of one or each side of the locking bar.

Having described our invention, we claim:

1. In an impulse starter for magnetos, a
 10 driving part and a driven part, the latter adapted to be connected to the magneto, a catch for temporarily holding the driven part against movement and holding means therefor comprising a locking member connected to the catch and a holding member
 15 mounted independently of the locking member past which the locking member moves and with which the locking member engages.

2. In an impulse starter for magnetos, a driving part and a driven part, the latter adapted to be connected to the magneto, a catch for temporarily holding the driven part against movement, a locking
 25 member connected to the catch, and a spring actuated member engaging the locking member, the latter having a position determining part which the spring actuated member is adapted to engage.

3. In an impulse starter for magnetos, a driving part and a driven part, the latter adapted to be connected to the magneto, a catch for temporarily holding the driven part against movement, a locking member
 35 connected to the catch provided with an inclined positioning part, and a detent adapted to engage it.

4. In an impulse starter for magnetos, a driving part and a driven part, the latter adapted to be connected to the magneto, a catch for temporarily holding the driven part against movement, a locking member
 40 connected to the catch provided with a V-shaped protuberance, and a detent adapted to engage it.

5. In an impulse starter for magnetos, a driving part and a driven part, the latter adapted to be connected to the magneto, a catch for temporarily holding the driven part against movement, a locking member
 50 for the catch provided with position determining parts, and detents on opposite sides of the locking member.

6. In an impulse starter for magnetos,

a driving part and a driven part, the latter adapted to be connected to the magneto, a catch for temporarily holding the driven part against movement, a locking member for the catch having a pair of oppositely disposed V-shaped protuberances, and a
 60 pair of spaced detents between which the locking member extends and adapted to ride up and down the inclined faces of the protuberances.

7. In an impulse starter for magnetos, a driving part and a driven part, the latter adapted to be connected to the magneto, a catch for temporarily holding the driven part against movement, a locking member
 65 connected to the catch, and a detent cooperating with the locking member, said detent having a limited movement in the direction of movement of the locking member.

8. In an impulse starter for magnetos, a driving part and a driven part, the latter adapted to be connected to the magneto, a catch for temporarily holding the driven part against movement, a housing enclosing the catch, a member for holding the
 80 catch in inoperative position and extending to the exterior of the housing, said member having its inner portion connected to the catch, and means engaging said member to hold the same in a position such that the catch is retained in inoperative position, said means permitting the catch to be
 85 thrown to operative position by inward pressure on said member and by substantially endwise inward movement thereof.

9. In an impulse starter for magnetos, a driving part and a driven part, the latter adapted to be connected to the magneto, a catch for temporarily holding the driven part against movement, a housing for holding the same, means for holding the catch
 95 in inoperative position comprising a holding member connected to the catch and extending out through said housing, said member moving outwardly in a substantially endwise direction when the catch is moved to inoperative position and being moved inwardly in a substantially endwise direction when the catch is moved to operative position.

In testimony whereof, we hereunto affix
 105 our signatures.

JOSEPH A. WILLIAMS.
 ALBERT G. KARKAU.