

June 26, 1973

G. GIORI

3,741,835

METHOD OF PREPARING COPPER-PLATE PRINTING PLATES FOR PRINTING

Filed May 1, 1970

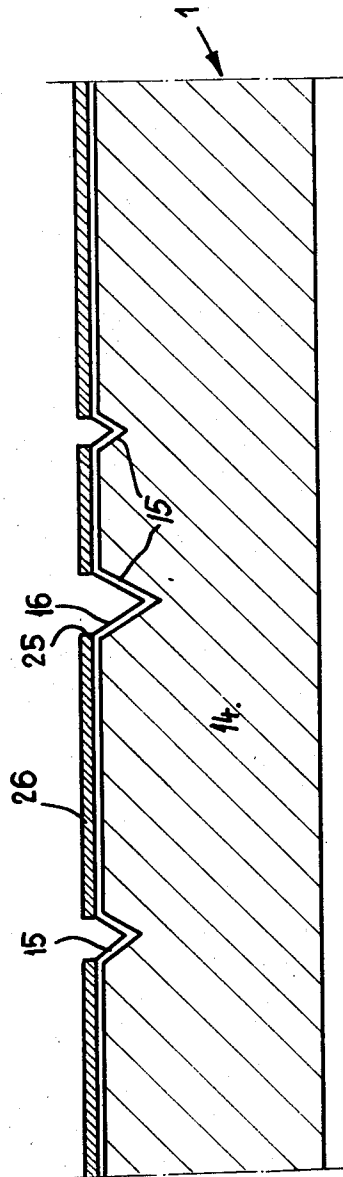

1

3,741,835

**METHOD OF PREPARING COPPER-PLATE
PRINTING PLATES FOR PRINTING**

Gualtiero Giori, Lausanne, Switzerland, assignor to
De la Rue Giori S.A., Lausanne, Switzerland
Filed May 1, 1970, Ser. No. 33,853
Claims priority, application Switzerland, May 8, 1969,
7,073/69

Int. Cl. B44n 3/02; C23g 1/20
U.S. Cl. 156—14 4 Claims

ABSTRACT OF THE DISCLOSURE

An engraved printing plate having an ink retaining surface of copper is prepared for printing by applying a layer of a material such as matt chrome which is repellent to ink but accepts a wetting agent over all of the surface. A protective coating is applied to the non-engraved part of the surface. This coating may be powdered bitumen applied to a film of printing ink and then fused by heat treatment. The layer of chrome is then removed from the engraved part of the surface by chemical or electrolytic means and the protective coating is then removed by solvents.

The present invention relates to processes for the preparation of copper-plate printing plates the engraved lines of which retain ink and the surface of which apart from the lines repels ink and retains a wetting agent. Such printing plates can be used in a copper-plate printing machine which works without wiping devices which have been used up to the present time. For this purpose, a device for applying wetting agent to the plate is situated before the conventional inking device. This wetting agent covering the surface of the plate apart from the engraved lines prevents the surface of the said plate from being inked, in such a way that during its passage by the inking device, the ink is only applied to the engraved lines.

According to a process suggested by the applicant (Swiss patent application No. 18,526/68) starting from an engraved plate with an ink-repellent material forming a layer covering the non-printing surface thereof, the engraved lines are filled with a material which repels metallic deposits after which a layer of a second material repellent to ink, but acceptable to a wetting agent, is then applied on the surface of the printing plate and, finally, the material filling the lines is removed.

The present invention concerns a process in which it is possible to eliminate filling the engraved lines with a filling material. According to the invention, there is provided a method for preparing a printing plate for printing, comprising providing an engraved printing plate having a surface in ink retaining material, applying a layer of a second material repellent to ink but accepting a wetting agent on said surface, and removing said layer from the engraved part of said surface.

After the layer of second material is deposited, the surface of the printing plate excluding the engraved part is preferably coated with a protective coating which is removed after the removal of the second material. The second material is preferably matt chromium and is removed from the engraved part by chemical or electrolytic means, the protective layer not being affected by this treatment. Advantageously, the protective layer is held by means of a coating of glue previously applied to the surface of the non engraved part of the printing plate, this coating of glue conveniently consisting of a conventional printing ink applied by means of an inking cylinder. The protective layer, consisting of powdered bitumen is next

2

applied to the damp coating of ink, fused by the application of heat and, after the removal of the second material from the engraved part, the protective layer and the ink are removed from the surface of the printing plate.

In order to improve the property of the second material for retaining a wetting agent, it is recommended that the plate is treated with an electrolytic aqueous solution containing ions which penetrate, for example by capillary action into the porous structure of the second material.

In such a manner, the outer layer forming the non-printing surface, preferably of matt chrome, is additionally impregnated with constituents capable of retaining the wetting agent and repelling ink.

A method of implementing the process according to the invention will now be described with reference to the accompanying drawing which is a diagrammatic cross-section through a printing plate at an intermediate stage of the method according to the invention.

The printing plate is indicated by the general reference numeral 1. On a copper plate 14 with engraved lines 15 is applied a layer 16 of chromium which has ink-repellent properties when covered by a wet film. This chromium layer can be deposited by chemical or electrolytic means.

Next, the non-printing surface of plate 14, i.e. the part not provided with engraved lines, is covered with a protective coating which is not affected by the later treatment for removal of the chromium layer 16 from the lines. For this purpose, the surface of the plate not having engraved lines 15 is covered with an adhesive layer 25, composed of a conventional printing ink or another similar material, by means of an inking cylinder. Care should be taken to prevent the ink from entering the lines 15. On the still damp coating 25 the so-called protective coating 26 is spread in powder form. Bitumen is preferably used for this purpose. The excess bitumen or other material used is shaken off and/or removed by compressed air, the powder being particularly carefully removed from the engraved lines. By suitable heating of the plate or only the surface thereof, the powder is brought to its fusion point so that it forms a solid bituminous layer 26. Simultaneously, the adhesive coating is dried in such a way that the protective coating only adheres to the surface of the plate where it is not provided with lines 15.

This protective coating is then capable of resisting a caustic or electrolytic treatment for removing the deposit of chromium 16 from the lines. During this treatment it is advantageous to ensure that all the chrome is removed but that the under-lying copper is not affected.

The next step consists of removing the protective coating from the surface of the plate. For this purpose the bitumen is firstly removed by treatment with naphtha or naphthalene, for example, after which the underlying coating of ink or adhesive 25 is dissolved by means of a suitable solvent such as phenol. The protective coating can also be removed by means of trichlorethylene. The finished printing plate is thus covered with a layer of chromium 16, which repels ink but retains the wetting agent, on the non-printing surface thereof which does not have any engraved lines, whilst the engraved lines are in copper which is an ink retaining material.

In order to further improve the properties of the chromium layer to retain the wetting agent, it is recommended that the plate be treated after the chromium deposit with an electrolytic aqueous solution, preferably brought to a temperature of between 50° C. and 90° C., and which contains ions which penetrate the porous structure of the chromium especially by capillary action, and which increase the desired property of retaining a wetting agent. In this way, the chromium is additionally impregnated with

constituents capable of retaining a wetting agent and repelling ink and which are attached to the chromium by chemical reaction.

As the electrolytic solution, it is preferable to use a wetting agent, the composition of which is similar to that which is applied during printing for wetting the surface of the plate: such agents are known, for example, in offset printing methods. This electrolytic solution may be alkaline and contain phosphates, for example.

In order to improve this effect even more it is advantageous to add an adhesive such as gelatine or gum arabic to the electrolytic solution. Thus a layer having good wetting agent retaining properties which are maintained over a period of time is obtained. When the treatment takes place before the application of the protective coating, the trichlorethylene applied to remove this layer does not affect this impregnation because trichlorethylene has only physical solubility effects.

On the other hand, treatment of the plate with this electrolytic solution can only be made after removal of the protecting coating. Consequently, the possible traces of trichlorethylene or other solvents employed for the removal of this protective coating are removed from the chromium by the constituents of the electrolytic solution so as to ensure the complete removal of the trichlorethylene or other solvent used from the chromium.

It has been found in practice that using the process according to the invention it is possible to manufacture copper printing plates having engraved lines with a depth of up to 0.05 mm. for example.

As the mechanical resistance of copper used for these printing plates is low, the plate itself, designated by 14, is made of nickel, engraved with lines, on which a layer of copper is applied, for example by condensation in a vacuum before carrying out the above-described process. A copper layer 0.0025 mm. thick is sufficient. The treatment of the plate is carried out as described hereinabove. After removal of the chromium 16 from the engraved lines, the underlying layer of copper, which is not affected by the treatment, forms an ink-retaining surface.

The invention is not limited to the described embodiment. As far as concerns the material which accepts or repels ink and retains the wetting agent, this can be any substance which has these properties and which can be deposited on the printing plate. The protective layer can also consist of any suitable material which resists the treatments for the removal of the ink-repellent material from the engraved lines. This latter treatment can be carried out by any known mechanical, chemical or electrolytic method or even an electrical process such as electro-erosion, or by a combination of such methods.

For the removal of the protective layer, other known mechanical, chemical or electro-chemical methods can be used, and this treatment can be followed by a polishing operation to finish the surface of the plate.

It is possible to eliminate the application of a protective layer 25 and 26 if, after application of the ink-repellent but wetting agent retaining layer and, possibly, after treatment with an electrolytic solution, this the protective layer is removed from the engraved lines by a suitable treatment, without damaging the layer of the material covering the non-printing surface of the plate not provided with engraved lines.

What is claimed is:

1. An improved method for preparing an engraved copper faced printing plate which comprises:

- (a) applying to the entire surface of the engraved copper faced plate a primary layer of chromium which is repellent to ink but readily accepts a wetting agent,
- (b) adhesively applying a protective coating to the non-engraved portion of the surface of the plate comprising ink and powdered bitumen,
- (c) removing the chromium layer from the engraved portions of the printing plate,
- (d) removing the protective layer of ink and bitumen from the non-engraved portion of the plate,
- (e) treating the chromium layer with an aqueous electrolytic solution of an alkaline phosphate and an adhesive for improving the ink repellent and wetting agent retaining characteristics of the chromium layer.

2. A method according to claim 1, wherein said chromium layer is removed as in step (c) by chemical or electrolytic means.

3. A method according to claim 1, wherein in step (b) a printing ink is applied to the non-engraved surface already coated with chromium and powdered bitumen is applied over the printing ink, the ink and bitumen fused and in step (d) this coating of fused ink and bitumen is removed by treatment with a first solvent to remove the bitumen and a second solvent to remove the printing ink.

4. A method according to claim 1, wherein the electrolytic solution contains an adhesive selected from the group consisting of gelatin or gum arabic.

References Cited

UNITED STATES PATENTS

1,420,086	6/1922	Fox	156—11
1,811,734	6/1931	Trist	204—17
2,102,162	12/1937	Nierenberg	156—11
2,731,333	1/1956	Ko et al.	156—11
2,203,849	6/1940	Trist	101—465
2,291,854	8/1942	Whyzmuzis	101—459
2,726,200	12/1955	Holsapple	204—17
1,182,623	5/1916	Bardsley	156—11
2,186,945	1/1940	Wood	101—451
3,478,684	11/1969	Schafier et al.	101—458

OTHER REFERENCES

Apps: "Inks for the Major Printing Process," (1963), p. 134 cited.

Abraham: Asphalts & Allied Substances (1945), p. 258 cited.

Ruemer: Inland Printer/Amer. Lith., pp. 90, 92, June 1965.

Diehl: Inland Printer/Amer. Lith., pp. 90, 92, August 1966.

Reid: "Offset Platemaking," Lithographic Tech. Foundation, pp. 152—156, 184; pub. December 1959.

GEORGE F. LESMES, Primary Examiner

R. J. ROCHE, Assistant Examiner

U. S. CI. X.R.

156—11; 204—17; 101—451, 458