



INTERNATIONAL APPLICATION PUBLISHED UNDER THE PATENT COOPERATION TREATY (PCT)

<p>(51) International Patent Classification <sup>7</sup> : <b>A61B 17/12</b></p>	<p><b>A1</b></p>	<p>(11) International Publication Number: <b>WO 00/51500</b> (43) International Publication Date: 8 September 2000 (08.09.00)</p>
<p>(21) International Application Number: PCT/US00/05682 (22) International Filing Date: 3 March 2000 (03.03.00) (30) Priority Data: 09/263,382 5 March 1999 (05.03.99) US (63) Related by Continuation (CON) or Continuation-in-Part (CIP) to Earlier Application US 09/263,382 (CON) Filed on 5 March 1999 (05.03.99) (71) Applicant (for all designated States except US): BOARD OF REGENTS, THE UNIVERSITY OF TEXAS SYSTEM [US/US]; 201 West Seventh Street, Austin, TX 78701 (US). (72) Inventors; and (75) Inventors/Applicants (for US only): KONYA, Andras [HU/US]; Apartment 256, 550 North Braeswood, Houston, TX 77096 (US). WALLACE, Sidney [US/US]; 3324 Pittsburgh, Houston, TX 77005 (US). WRIGHT, Kenneth, C. [US/US]; 1802 Haver, Houston, TX 77006 (US). (74) Agent: GARRETT, Mark, T.; Fulbright &amp; Jaworski L.L.P., Suite 2400, 600 Congress Avenue, Austin, TX 78701 (US).</p>		<p>(81) Designated States: AE, AL, AM, AT, AU, AZ, BA, BB, BG, BR, BY, CA, CH, CN, CR, CU, CZ, DE, DK, DM, EE, ES, FI, GB, GD, GE, GH, GM, HR, HU, ID, IL, IN, IS, JP, KE, KG, KP, KR, KZ, LC, LK, LR, LS, LT, LU, LV, MA, MD, MG, MK, MN, MW, MX, NO, NZ, PL, PT, RO, RU, SD, SE, SG, SI, SK, SL, TJ, TM, TR, TT, TZ, UA, UG, US, UZ, VN, YU, ZA, ZW, ARIPO patent (GH, GM, KE, LS, MW, SD, SL, SZ, TZ, UG, ZW), Eurasian patent (AM, AZ, BY, KG, KZ, MD, RU, TJ, TM), European patent (AT, BE, CH, CY, DE, DK, ES, FI, FR, GB, GR, IE, IT, LU, MC, NL, PT, SE), OAPI patent (BF, BJ, CF, CG, CI, CM, GA, GN, GW, ML, MR, NE, SN, TD, TG).</p> <p><b>Published</b> With international search report.</p>

(54) Title: OCCLUSION APPARATUS

(57) Abstract

An occlusion method and apparatus. The occluder includes elastically deformable members and a jacket. The elastically deformable members are secured in spaced relation and extend in arcuate conformation therebetween. The jacket covers at least a portion of the elastically deformable members. The elastically deformable members are configured to become compressed upon application of a force and to recover the arcuate conformation upon removal of the force to occlude a site.

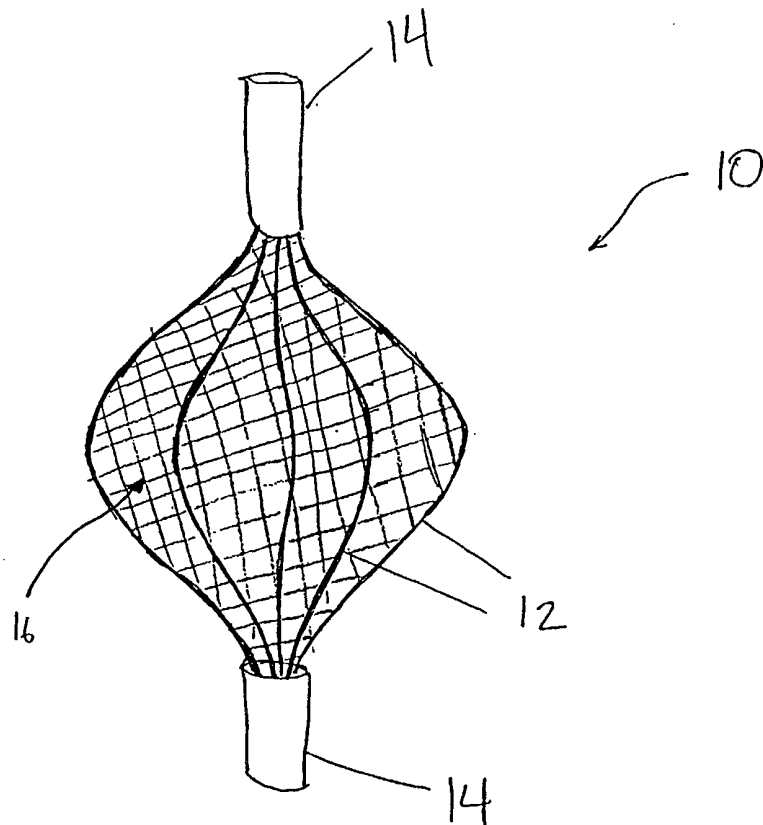

*FOR THE PURPOSES OF INFORMATION ONLY*

Codes used to identify States party to the PCT on the front pages of pamphlets publishing international applications under the PCT.

AL	Albania	ES	Spain	LS	Lesotho	SI	Slovenia
AM	Armenia	FI	Finland	LT	Lithuania	SK	Slovakia
AT	Austria	FR	France	LU	Luxembourg	SN	Senegal
AU	Australia	GA	Gabon	LV	Latvia	SZ	Swaziland
AZ	Azerbaijan	GB	United Kingdom	MC	Monaco	TD	Chad
BA	Bosnia and Herzegovina	GE	Georgia	MD	Republic of Moldova	TG	Togo
BB	Barbados	GH	Ghana	MG	Madagascar	TJ	Tajikistan
BE	Belgium	GN	Guinea	MK	The former Yugoslav Republic of Macedonia	TM	Turkmenistan
BF	Burkina Faso	GR	Greece			TR	Turkey
BG	Bulgaria	HU	Hungary	ML	Mali	TT	Trinidad and Tobago
BJ	Benin	IE	Ireland	MN	Mongolia	UA	Ukraine
BR	Brazil	IL	Israel	MR	Mauritania	UG	Uganda
BY	Belarus	IS	Iceland	MW	Malawi	US	United States of America
CA	Canada	IT	Italy	MX	Mexico	UZ	Uzbekistan
CF	Central African Republic	JP	Japan	NE	Niger	VN	Viet Nam
CG	Congo	KE	Kenya	NL	Netherlands	YU	Yugoslavia
CH	Switzerland	KG	Kyrgyzstan	NO	Norway	ZW	Zimbabwe
CI	Côte d'Ivoire	KP	Democratic People's Republic of Korea	NZ	New Zealand		
CM	Cameroon		Republic of Korea	PL	Poland		
CN	China	KR	Republic of Korea	PT	Portugal		
CU	Cuba	KZ	Kazakstan	RO	Romania		
CZ	Czech Republic	LC	Saint Lucia	RU	Russian Federation		
DE	Germany	LI	Liechtenstein	SD	Sudan		
DK	Denmark	LK	Sri Lanka	SE	Sweden		
EE	Estonia	LR	Liberia	SG	Singapore		

## DESCRIPTION

### OCCLUSION APPARATUS

#### BACKGROUND OF THE INVENTION

5           **1. Field of the Invention**

The present invention relates generally to the field of occlusion of vessels and other tubular structures in the body. More particularly, it concerns a method and apparatus for repositionable, self-anchoring occlusion including vascular and ureter occlusion.

10

**2. Description of Related Art**

Percutaneous occlusion techniques have become indispensable tools in minimally invasive management of a wide range of pathological conditions. Use of permanent mechanical occlusion devices has been shown to be equivalent to that of surgical ligation. The Gianturco-Wallace stainless steel coil (Cook Inc., Bloomington, IN) has been the most widely used permanent, expandable intravascular occlusion device for transcatheter delivery (Gianturco *et al.*, 1975). The use of detachable balloons, another effective mechanical occlusion technique, has been largely abandoned in the United States because of safety concerns (Sharaffuddin *et al.*, 1996).

20

Percutaneous coil embolization has been shown to be advantageous over traditional surgical procedures in treatment of life threatening hemorrhage due to trauma or obstetric emergencies (Schwartz *et al.*, 1993; Teitelbaum *et al.*, 1993; Selby Jr., 1992; Levey *et al.*, 1991; Ben-Menachem *et al.*, 1991; Vedantham *et al.*, 1997). Furthermore, coils have been used alone or in combination with microvascular embolic agents for the treatment of vascular fistulas and malformations, tumors, and varices (Wallace *et al.*, 1979; Hendrickx *et al.*, 1995; Furuse *et al.*, 1997; White *et al.*, 1996; Sagara *et al.*, 1998; Punekar *et al.*, 1996). During the last few years, the

25

transcatheter closure of the patent ductus arteriosus (PDA) with coils has become a frequently used technique (Hijazi and Geggel, 1994; Hijazi and Geggel, 1997).

Although coil type occlusion devices have shown at least a degree of utility, they have a number of drawbacks that could be significant in some applications. Intravascular stability of the coils has been shown to be highly dependent on proper matching of coil diameter with the diameter of the target vessel (Nancarrow *et al.*, 1987), and with the exception of small vessels, a single coil rarely results in a stable occlusive thrombus (Hijazi and Geggel, 1994). Moreover, a long vascular segment is often obliterated because of the frequent need for multiple coils and the coils often remain elongated within the vessel because their unconstrained diameter is larger than the vascular lumen. Furthermore, delayed recanalization rates of 37%-57% have been reported in humans within 1-3 months after initially successful coil embolization (Sagara *et al.*, 1998; O'Halpin *et al.*, 1984; Schild *et al.*, 1994).

These and other drawbacks have inspired modifications in the design and technique of coil embolization. Recently, detachable microcoils and macrocoils with controlled delivery have been designed to achieve a more compact conglomerate of the coil and to prevent migration by allowing optimal positioning of the coil before release (Zubillaga *et al.*, 1994; Guglielmi *et al.*, 1995; Marks *et al.*, 1994; Reidy and Qureshi, 1996; Uzun *et al.*, 1996; Tometzki *et al.*, 1996; Dutton *et al.*, 1995). However, since optimal arrangement of the coil alone may not prevent migration in some cases, such as high flow conditions or venous placement, a coil anchoring system has been devised (Konya *et al.*, 1998). Although an anchoring system may stabilize a coil conglomerate within the vasculature, significantly reducing or eliminating the possibility of coil migration, such a system may render the coil non-repositionable.

Several different non-coil devices have been designed to achieve a more stable, limited size plug with higher hemostatic efficiency particularly for transcatheter closure of larger vessels (Schmitz-Rode *et al.*, 1993) and PDAs (Pozza *et*

al., 1995; Magal *et al.*, 1989; Grifka *et al.*, 1996). Recently, initial clinical experiences with a new mesh PDA occluder have been reported (Sharafuddin *et al.*, 1996; Masura *et al.*, 1998). A similar self-expanding, repositionable quadruple-disc device constructed of a braided nitinol mesh and polyester fibers has been reported to be superior to standard Gianturco coils in experimental occlusion of mid-size arteries (Sharaffuddin *et al.*, 1996).

Although such non-coil devices may be repositionable, they too exhibit drawbacks. For instance, the quadruple-disc device is several centimeters long in an elongated fashion, making difficult to keep the superselective position of the catheter tip during deployment. Although the mesh-PDA occluder has demonstrated utility, its proper placement requires a proper match both in size and shape between the occluder and the lesion to be occluded. A common disadvantage of both designs is that they lack guidewire compatibility. As a result, a delivery catheter must often be navigated to the site of occlusion first before an occluder may be loaded into the catheter and delivered through it. Another relative disadvantage of both devices is their cost of manufacturing.

Percutaneous catheter technique for permanent closure of isolated persistently patent ductus arteriosus (PDA) is now a treatment of choice among doctors, obviating open surgery. The configuration of the PDA varies considerably. A majority of PDAs tend to have a funnel or conical shape due to ductal smooth muscle constriction at the pulmonary artery insertion, although narrowings in the middle or aortic ends can be observed (Krichenko, 1989). That is the reason why not only the size, but also the configuration, of the lesion plays a significant role in selecting an appropriate occluding device. Except from the small caliber lesions (with a maximum diameter of 2.5 mm or 3.3 mm, respectively), where some authors have achieved successful closure of the PDA with Gianturco coils (Cambier, 1992; Lloyd, 1993; Sommer, 1994), Rashkind's "double umbrella" occluder is the most often used device for this purpose (Rashkind, 1987; Hosking, 1991; Latson, 1991; Wessel, 1988; Report of the

European Registry, 1992). It is available in two sizes (with a diameter of 12 mm and 17 mm) which require a 8-P and 11-F delivery system, respectively.

5 In the majority of cases, the deployment of the traditional PDA device is performed from a femoral vein access (Report of the European Registry, 1992). Because of the size of the delivery sheath, such a device is not suitable for the treatment of patients with a body weight of less than 8 kg. Using even a larger umbrella, this procedure is not recommended for the treatment of the lesions with a diameter of 8 mm or above (Latson, 1991). About 80% of unselected patients with 10 isolated PDA are candidates for the Rashkind device using the aforementioned criteria (Latson, 1991). With the Rashkind device, the proportion of patients with residual flow through the lesion fell from 76% immediately after implantation to 47% by the day after implantation and to 17% by a year after implantation (Report of the European Registry, 1992). According to some authors the residual flow carries a 15 potential risk of infective endocarditis and should be avoided if possible. Its abolishment can be achieved by implantation of another device or surgery.

One of the main drawbacks of the Rashkind umbrella is that it is not suitable for occlusion of all types of PDA. Preferably, it is used to occlude short PDAs with 20 relatively wide end-openings. Its two discs cover both the pulmonary and the aortic opening of the PDA. Longer PDA may hinder the discs to be positioned in the proper way, that is, parallel to each other, thereby deteriorating its self-anchoring. Another disadvantage of the umbrella is that the occluding capacity of the design depends exclusively on the thrombogenicity of the porous Dacron material, frequently 25 resulting in partial and lengthy occlusion.

For the majority of patients with urinary leakage and/or fistulas (mainly due to tumor propagation to their ureters), the diversion of urine is currently performed by a percutaneous transrenal approach together with ureteral occlusion. Formerly, 30 detachable and non detachable balloons were used for this purpose, but they did not cause satisfactory ureteral occlusion. Migration as well as deflation of the balloons

occurred relatively frequently (Gunter, 1984; Papanicolau, 1985) leading to recurrence of the urine leakage. A silicone ureteral occluder was developed and used with only limited success because of device migration (Sanchez, 1988). This resulted in repositioning and consequent incomplete ureteral occlusion. It appears that the best results have been accomplished with Gianturco coils and Gelfoam embolization (Bing *et al.* 1992 a; ). Even with multiple coil placements, together with Gelfoam plugs, the ureteral occlusion may sometimes be achieved for only weeks or months, and was attributed mostly to the induced urothelial hyperplasia (Bing *et al.*, 1992 b). Coil migration was frequently encountered in these studies. The lack of appropriate self-anchoring results in coil migration which eventually deteriorates the occlusive effect.

Problems pointed out in the foregoing are not intended to be exhaustive but rather are among many that tend to impair the effectiveness of previously known occlusion systems. Other noteworthy problems may also exist; however, those presented above should be sufficient to demonstrate that previous techniques appearing in the art have not been altogether satisfactory, particularly in providing fast, non-migratory, self-anchoring, repositionable occlusion.

### SUMMARY OF THE INVENTION

In one aspect, the invention is an occluder including a elastically deformable members, and a jacket. As used herein, by "elastically deformable" it is meant that deformation is non-permanent and an original shape may be substantially recovered, or regained, upon the release of a force (which may be mechanical, electromagnetic, or any other type of force). By "substantially recovered", it is meant that recovery need not be such that the exact original shape may be regained. Rather, it is meant that some degree of plastic deformation may occur. In other words, recovery need not be total. The plurality of elastically deformable members are secured in spaced relation and extend in arcuate conformation therebetween. The plurality of elastically deformable members are operable to become compressed upon application of a force and to recover the arcuate conformation upon removal of the force. The jacket is in

operable relation to the plurality of elastically deformable members and is configured to cover at least a portion of the plurality of elastically deformable members.

5 In other aspects, the plurality of elastically deformable members may be programmed with thermal memory. The plurality of elastically deformable members may be programmed with superelasticity. The plurality of elastically deformable members may be secured at their ends. The occluder may also include one or more anchors defined by one or more ends of the plurality of elastically deformable members. The occluder may also include a pair of clips in spaced relation for  
10 securing the plurality of elastically deformable members. At least one of the clips may be interdigitated. The occluder may also include an eye in operable relation to at least one of the clips. The jacket may include dacron. The jacket may include polyurethane. The plurality of elastically deformable members may include four or more nitinol wires. The occluder may also include an occluding agent enclosed  
15 within the jacket. The occluding agent may include one or more threads of polyester.

In another aspect, the invention is an occlusion system including an occluder and a delivery system. The occluder includes a pair of clips, a elastically deformable members, and a jacket. The pair of clips are configured in spaced relation. The  
20 plurality of elastically deformable wires are secured by the clips and extend in arcuate conformation therebetween. The plurality of elastically deformable wires are operable to become compressed upon application of a force and to recover the arcuate conformation upon removal of the force. The jacket is in operable relation to the plurality of elastically deformable wires and is configured to cover at least a portion of  
25 the plurality of elastically deformable wires. The delivery system includes a guiding catheter and a pushing catheter. The guiding catheter is configured to receive the occluder. The guiding catheter compresses and guides the plurality of elastically deformable wires. The pushing catheter is configured to engage at least one of the pair of clips to slide the occluder relative to the guiding catheter.



In other aspects, the plurality of elastically deformable wires may include four, five, or six nitinol wires. The plurality of elastically deformable wires may be programmed with thermal memory. The plurality of elastically deformable wires may be programmed with superelasticity. The occluder may also include one or more anchors defined by one or more ends of the plurality of elastically deformable wires. The jacket may include dacron. The jacket may include polyurethane. The occluder may also include an occluding agent enclosed within the jacket. The occluding agent may include one or more threads of polyester. The occluder may also include an eye in operable relation to at least one of the clips, and the delivery system may also include a retrieval filament configured to engage the eye to retrieve the occluder. At least one of the clips may be an interdigitated clip. An end of the pushing catheter may be interdigitated and may be configured to removably interlock with the interdigitated clip. The system may also include a lumen defined through the occluder and the delivery system. The delivery system may also include a guide wire within the lumen and passing through an interior of the occluder. The delivery system may also include a stiffening catheter configured to engage at least one of the clips to compress the occluder.

In another aspect, the invention is a method for occluding an occlusion site. An occluder including a pair of clips configured in spaced relation, a plurality of elastically deformable wires secured by the clips and extending in arcuate conformation therebetween, and a jacket in operable relation to the plurality of elastically deformable wires is provided. A delivery system including a guiding catheter configured to receive the occluder and a pushing catheter configured to engage at least one of the pair of clips is provided. The guiding catheter is positioned adjacent the occlusion site. The occluder is positioned within the guiding catheter. At least one of the pair of clips is engaged with the pushing catheter. The occluder is slide relative to the guiding catheter with the pushing catheter so as to deploy the occluder from the guiding catheter so as to recover the arcuate conformation to occlude the occlusion site.

In other aspects, the occluder may also include one or more anchors defined by one or more ends of the plurality of elastically deformable wires, and the method may also include anchoring the occluder at the occlusion site with the one or more anchors. At least one of the clips may be an interdigitated clip, and an end of the pushing catheter may be interdigitated, and the method may also include retrieving the occluder by interlocking the interdigitated clip with the interdigitated end of the pushing catheter by drawing at least a portion of the occluder within the guiding catheter. The method may also include repositioning the occluder. The occluder and delivery system may also include an eye in operable relation to at least one of the clips and a retrieval filament configured to engage the eye, and the method may also include retrieving the occluder by drawing at least a portion of the occluder within the guiding catheter with the retrieval filament. The method may also include repositioning the occluder. The occluder may also include a lumen defined through the occluder and a guide wire configured to pass within the lumen, and the method may also include guiding the occluder toward the occlusion site with the guide wire. The delivery system may also include a stiffening catheter configured to engage at least one of the clips, and the method may also include engaging the at least one of the clips with the stiffening catheter and compressing the occluder with the stiffening catheter by increasing the distance between the pair of clips. The occlusion site may be a vascular occlusion site. The occlusion site may be a ureter occlusion site. The occlusion site may be a patent ductus arteriosus site.

In another aspect, the invention is a method for closure of patent ductus arteriosus having an aortic and pulmonary side. An occluder including a pair of clips configured in spaced relation, a plurality of elastically deformable wires secured by the clips and extending in arcuate conformation therebetween, and a jacket in operable relation to the plurality of elastically deformable wires is provided. A delivery system including a guiding catheter configured to receive the occluder and a pushing catheter configured to engage at least one of the pair of clips is provided. The guiding catheter is positioned adjacent the patent ductus arteriosus. The occluder is positioned within

the guiding catheter. The occluder is deployed from the guiding catheter so as to recover the arcuate conformation to close the patent ductus arteriosus.

In other aspects, the occluder may also include a guide wire in operable  
5 relation to the guiding catheter, and the method may also include guiding the occluder toward the patent ductus arteriosus with the guide wire. The positioning may include positioning the occluder on the pulmonary side.

Other features and advantages of the disclosed method and apparatus will  
10 become apparent with reference to the following detailed description of embodiments thereof in connection with the accompanying drawings wherein like reference numerals have been applied to like elements, in which:

#### **BRIEF DESCRIPTION OF THE DRAWINGS**

15

**FIG. 1** shows an occluder according to one embodiment of the presently disclosed method and apparatus.

**FIG. 2** shows an occluder being programmed with superelasticity or thermal  
20 memory according to one embodiment of the presently disclosed method and apparatus.

**FIG. 3A** shows an occluder being programmed with superelasticity or thermal  
25 memory according to another embodiment of the presently disclosed method and apparatus.

**FIG. 3B** shows a top view of an occluder being programmed according to one embodiment of the presently disclosed method and apparatus.

**FIG. 4** shows an occluder in a semi-compressed state according to one  
30 embodiment of the presently disclosed method and apparatus.

**FIG. 5** shows an occluder in a compressed state according to one embodiment of the presently disclosed method and apparatus.

5       **FIG. 6** shows an extended occluder according to one embodiment of the presently disclosed method and apparatus.

**FIG. 7** shows a top view of an occluder according to one embodiment of the presently disclosed method and apparatus.

10

**FIG. 8** is a side view of an occluder having anchors according to one embodiment of the presently disclosed method and apparatus.

**FIG. 9** is a side view of an extended occluder having anchors according to one  
15       embodiment of the presently disclosed method and apparatus.

**FIG. 10** is a top view of an occluder having anchors according to one embodiment of the presently disclosed method and apparatus.

20       **FIG. 11** shows an occluder including an occluding agent according to one embodiment of the presently disclosed method and apparatus.

**FIG. 12** shows an occluder having an interdigitated end corresponding to an interdigitated end of a pushing catheter according to one embodiment of the presently  
25       disclosed method and apparatus.

**FIG. 13** shows an occluder having anchors and an interdigitated end corresponding to an interdigitated end of a pushing catheter according to one embodiment of the presently disclosed method and apparatus.

30

**FIG. 14** shows a deployed occluder and guide wire according to one embodiment of the presently disclosed method and apparatus.

**FIG. 15** shows a compressed occluder within a guiding catheter according to one embodiment of the presently disclosed method and apparatus.

**FIG. 16** shows a detailed view of a guide wire, a guiding catheter, and an interdigitated pushing catheter according to one embodiment of the presently disclosed method and apparatus.

**FIG. 17** shows an occluder utilizing a stiffening catheter according to one embodiment of the presently disclosed method and apparatus.

**FIG. 18** shows a detailed view of a guide wire, stiffening catheter, and occluder cap according to one embodiment of the presently disclosed method and apparatus.

**FIG. 19** is a side view of an occluder occluding an occlusion site according to one embodiment of the presently disclosed method and apparatus.

**FIG. 20** is a top view of an occluder occluding an occlusion site according to one embodiment of the presently disclosed method and apparatus.

**FIG. 21** shows an occluder closing a patent ductus arteriosus according to one embodiment of the presently disclosed method and apparatus.

**FIG. 22** shows an occluder with anchors closing a patent ductus arteriosus according to one embodiment of the presently disclosed method and apparatus.

### DESCRIPTION OF ILLUSTRATIVE EMBODIMENTS

It will be appreciated that the presently disclosed method and apparatus provide for certain significant advantages. For instance, in one embodiment, the method and apparatus allow for occlusion that is faster than that of previous techniques. Achieving better coverage of a given occlusion site, the technique of this embodiment advantageously provides quick mechanical blockage of blood and induces thrombosis that leads to quick occlusion. The method and apparatus of this embodiment also advantageously provide a mechanism for self-anchoring occlusion. The self-anchoring, in turn, tends to greatly reduce or eliminate migration of the occlusion device and, hence, reduces or eliminates problems associated with migration.

Various embodiments of the disclosed method and apparatus offer further advantages. These advantages include ease of positioning and compactness. Specifically, the apparatus may easily achieve a 6-French size. Yet another advantage is repositionability. Because the presently disclosed occluder may be retrieved, it may be easily repositioned, and, hence, may provide for prompt correction of misplacements. Yet another advantage is guidewire compatibility, which facilitates navigation through a patient. The method and apparatus also advantageously provide safe, controllable occluder deployment with precise positioning capabilities. Such features make possible successful vascular, ureter, and patent ductus arteriosus closure.

Additionally, in one embodiment, the presently disclosed method and apparatus is suitable for transarterial approaches and especially for transvenous approaches. The design is adaptable to various PDA shapes and sizes. The length of the disclosed apparatus is still acceptable even when in an elongated state. These and other advantages will be made more clear with reference to the description below.

Turning first to FIG. 1, there is shown an occluder **10** according to one embodiment of the presently disclosed method and apparatus. Occluder **10** includes a pair of clips **14**, a plurality of elastically deformable members **12**, and a jacket **16**. In operation, occluder **10** may be positioned at an occlusion site to mechanically block  
5 blood passage and to induce thrombosis.

Elastically deformable members **12** may be configured to assume an arc, or bowed shape, as shown in FIG. 1. Such a shape may facilitate occlusion, for an outer surface of elastically deformable members **12** may engage and press against an inner  
10 surface of an opening, firmly anchoring occluder **10** and creating a mechanical blockage of blood flow (see, *e.g.*, FIG. 19). Elastically deformable members **12** may be configured so that they may be compressed upon application of a force so that they may be positioned within an opening without substantially engaging the inner surface of that opening (see, *e.g.*, FIG. 5). For instance, when compressed, elastically  
15 deformable members **12** may be placed within a guiding catheter (see, *e.g.*, FIG. 15) so that occluder **10** may be brought into position adjacent an occlusion site. Being compressible, elastically deformable members **12** may also be repositioned about or withdrawn from an occlusion site. Due to their elastic nature, elastically deformable members **12** may substantially recover their bowed shape upon removal of a force. In  
20 particular, elastically deformable members **12** may be made to resiliently spring back into a bowed shape to anchor occluder **10** when deployed from a constraining guiding catheter.

In one embodiment, elastically deformable members **12** may be made from  
25 any material suitable to become elastically deformed such that occluder **10** may be compressed and may thereafter substantially recover its original, uncompressed, arcuate shape. In one embodiment, elastically deformable members **12** may be nitinol wires, but, again, any other material suitable to exhibit elastic deformations as described herein may be substituted therewith. The number of elastically deformable  
30 members **12** may vary widely, but in one embodiment, the number of elastically deformable members **12** may be from four to six. The material making up elastically

deformable members **12** may be chosen to exhibit biocompatibility suited for a particular application.

In one embodiment, elastically deformable members **12** may be secured in spaced relation with clips **14** and may assume an arcuate conformation between those clips. In the embodiment of FIG. 1, elastically deformable members **12** are secured in longitudinally spaced relation by being coupled at their ends to clips **14**. In one embodiment, the coupling of elastically deformable members **12** to clips **14** may be accomplished by crimping. However, with the benefit of the present disclosure, those of skill in the art will understand that elastically deformable members **12** may be coupled to clips **14** by any suitable technique known in the art including, but not limited to, welding, gluing, taping, hooking within clips **14**, interlocking with clips **14**, clamping, or the like. In one embodiment, clips **14** may be made from stainless steel or nitinol, but any other suitable material may be utilized. Again, the material making up clips **14** may be chosen to exhibit an appropriate degree of biocompatibility.

Although shown in FIG. 1 as being secured at their ends, elastically deformable members **12** may be secured at other locations in other embodiments. For instance, in the embodiment of FIG. 8, to be described below, the securing of elastically deformable members **12** does not occur at the ends of elastically deformable members **12**. Although the securing mechanism of the embodiment of FIG. 1 involves clips **14**, other embodiments may provide securement by other means. For instance, other embodiments may secure elastically deformable members **12** by twisting their ends together or by tying or joining a filament or other suitable device about those ends. It is contemplated that many other alternative methods known in the art may be utilized to secure elastically deformable members **12**. In one embodiment, elastically deformable members **12** may be made from 5 nitinol wires. Although the size of the wires may vary widely, in one embodiment, the diameters may range anywhere from about 0.006 to about 0.011 inches.



In one embodiment, elastically deformable members **12**, such as nitinol wires, may be programmed with superelasticity or thermal memory as illustrated in FIG. 2, FIG. 3A, and FIG. 3B. In particular, they may be programmed to substantially recover an arcuate shape, such as the one shown in FIG. 1, upon removal of a  
5 compressing force. Programming of superelasticity or thermal memory may be accomplished by any one of a number of techniques known in the art. In one embodiment utilizing nitinol wires having a diameter ranging anywhere from about 0.006 to 0.011 inches, programming may be achieved by first forming a desired arcuate shape. For instance, spacing between clips **14** may be decreased such that a  
10 desirable arc shape is formed. To achieve an even more bowed shape (*e.g.*, to achieve a flat disc configuration), clips **14** may be brought very close together as is shown in FIG. 6.

Having achieved a desired shape, elastically deformable members **12** may be  
15 secured into place by any suitable means. For instance, in one embodiment, elastically deformable members **12** may be securedly wrapped around a ring of material, such as copper, so that elastically deformable members **12** assume a desired arcuate shape. In the embodiment of FIG. 2, FIG. 3A, and FIG. 3B, portion **15** of elastically deformable members **12** may be secured to copper ring **21**, used as a  
20 cylindrical template, by being threaded through holes **23** formed in the ring **21**. It will be understood that the number and arrangement of holes **23** may vary according to the desired shape of elastically deformable members **12**. In the illustrated embodiments, elastically deformable members **12** are threaded through adjacent holes **23** in ring **21** that surround the body of occluder **10**. Being stretched so as to be threaded through  
25 the ring **21**, elastically deformable members **12** may be made to form a desired arcuate shape. In one embodiment, holes **23** may be created parallel to the axis of ring **21** so that elastically deformable members **12** of occluder **10** may be arranged in planes that are perpendicular to the longitudinal axis of ring **21** (see FIG. 2). If holes **23** are arranged obliquely, elastically deformable members **12** of occluder **10** may be twisted  
30 (see FIG. 3A and FIG. 3B, FIG. 3B being a top view). It will be understood that any desirable shape may be formed in accordance with the present disclosure.

Being secured in place, elastically deformable members **12** may be exposed to heat for a certain period of time to complete the programming. In one embodiment, heat exposure may be about 500 degrees Celsius, and the exposure time period may  
5 be about 5 to about 15 min to achieve superelasticity or about 60 to about 120 min to achieve thermal memory. With programming complete, elastically deformable members **12** may easily be compressed to form a compressed-state occluder **10** (see, *e.g.*, FIG. 5) at room temperature. With the benefit of the present disclosure, those of skill in the art will understand that different times and temperatures may be used to  
10 achieve programming of elastically deformable members **12**. Also, it will be understood that other methods may be used to accomplish superelasticity or thermal memory, and it will also be understood that such programming is optional -- elastically deformable members **12** made of appropriate elastic materials may be adapted to substantially recover an arcuate shape upon removal of a force naturally  
15 (*i.e.* without any need for heat or other types of programming).

In one embodiment, thermal shape memory may provide sufficient expansile force to prevent migration of occluder **10** within, for instance, a vessel. At room temperature, elastically deformable members **12** may easily be straightened for  
20 loading the occluder **10** into a lumen of a guiding sheath **40** (discussed in detail with reference to FIG. 12, FIG. 13, and FIG. 15). Again, although temperature dependent shape memory may be used for fabrication of the devices disclosed herein, similar functional characteristics may be achieved by utilizing non-temperature dependent properties of materials, and more particularly, the non-temperature dependent  
25 superelasticity of nitinol.

Configurations of occluders **10** described herein offer a wide range of geometrical variations. Lengths of occluders **10** may vary widely according to application, but in one embodiment, the length may be between about 17 and 29 mm.  
30 To create different occluder shapes, the distance between clips **14** (or other securing mechanisms) holding the wires together and the arrangement of elastically deformable

members **12** may be altered. If the distance between clips **14** is decreased as much as possible (see, *e.g.*, FIG. 6), four elastically deformable members **12** may form a four-leaf clover shape. Such an arrangement of elastically deformable members **12** may result in a flat-disc design. If the distance between clips **14** is increased, elastically  
5 deformable members **12** may form an oval or spherical basket. Due to its ability to take on different sizes and shapes, occluders **10** disclosed herein may advantageously occlude a wide variety of differently sized and shaped occlusion sites.

In one embodiment, elastically deformable members **12** may be arranged at  
10 approximately 90 degrees to each other, although it will be understood than any suitable other angle may be used. In one embodiment, elastically deformable members **12** may be parallel to one another in the mid-portion of occluder **10**. Such a configuration may result in improved contact with a vessel wall and may provide better coverage within a vessel lumen. In one embodiment, elastically deformable  
15 members **12** may be configured in a spiral shape that may provide a more even distribution of members around the circumference of the occluder without requiring additional members.

In one embodiment, jacket **16** may be configured to cover at least a portion of  
20 elastically deformable members **12**. Jacket **16** may facilitate the mechanical blockage of an occlusion site and may induce further thrombosis. Jacket **16** may be made of any material suitable to cover at least a portion of elastically deformable members **12**, but in one embodiment, a woven material may be used. More particularly, in one embodiment a woven dacron material may be used as jacket **16**. Such woven dacron  
25 may be particularly well suited for vascular and patent ductus arteriosus occlusion. In other embodiments, different material may be used, such as polyurethane. Polyurethane, or other impermeable materials, may be particularly well suited for ureter occlusion. In such an embodiment, a polyurethane jacket may have a thickness of about 0.002 inches, but it will be understood than any suitable thickness may be  
30 substituted therewith. In embodiments well suited for ureter occlusion, a suitable lubricant may be used to decrease the friction between jacket **16** and walls of a

guiding catheter **40** (discussed with reference to FIG. 12, FIG. 13, and FIG. 14). In such embodiments utilizing polyurethane or impermeable jackets, the attachment of jacket **16** may need to be loosened so as to allow air to pass through occluder -- otherwise, a vacuum may be formed within occluder **10**, and the vacuum may prevent  
5 the complete opening of occluder **10** upon deployment.

In one embodiment, jacket **16** may be made to cover elastically deformable members **12** by pulling jacket **16** material over elastically deformable members **12** and attaching the material to crimping sites at, in, or near caps **14**. Although any suitable  
10 attachment technique known in the art may be used, in one embodiment, jacket **16** is attached to a crimping site with 5-0 or 6-0 Prolene monofilament sutures.

Turning now to FIG. 2, FIG. 3, and FIG. 4, there are shown occluders **10** in various stages of compression. FIG. 4 shows a snapshot of an occluder **10** in a semi-  
15 compressed state. In this state, occluder **10** may be resiliently rebounding to substantially recover its original arcuate shape or may be showing the first signs of being compressed. The shape of FIG. 4 may be seen, for instance, when an occluder **10** is only partially deployed from a guiding catheter, or when occluder **10** has begun to be retrieved from an occlusion site for repositioning. FIG. 5 shows an occluder **10**  
20 in a compressed state. As illustrated, elastically deformable members **12** may be substantially straight, extending longitudinally between secured positions, here secured by caps **14**. In this state, occluder **10** may be positioned inside, for instance, a guiding catheter (see, *e.g.*, FIG. 15). This position may be achieved through the application of a force to elastically deformable members **12**. In particular, this  
25 configuration may be achieved through the application of one or more compression forces directed towards the interior of occluder **10**. Such force, or compression forces, may be achieved with a guiding catheter whose inner surfaces exert compressing forces about outer surfaces of elastically deformable members **12**. This configuration, or any compressed configuration, may also be achieved by increasing the distance  
30 between secured portions of elastically deformable members **12**. For instance, by increasing the distance between caps **14**, occluder **10** may be compressed. FIG. 6

shows an occluder **10** that is extended to a great degree. As illustrated, caps **14** may be brought very close together so that elastically deformable members **12** assume an exaggerated bow shape. Such a configuration may be useful for occluding a wide occlusion site. In one embodiment, an expansion ratio (diameter after delivery divided by constrained diameter within a guiding catheter) of an occluder **10** according to the present disclosure may be about 5.6 (unconstrained diameter being about 15 mm, constrained diameter within a 8-F ID sheath being about 2.7 mm).

FIG. 7 shows a top view of an occluder **10**. The shape of the top view depends, of course, upon the extent of compression of occluder **10** and the number of elastically deformable members **12**. A top view corresponding to the fully compressed embodiment of FIG. 5 may be, for instance, nearly circular and thin. However, the top view of the embodiment illustrated in FIG. 6 may be shaped like a wide, exaggerated four-leaf clover. For embodiments such as those shown in FIG. 1 or FIG. 4, the shape may be similar to that shown in FIG. 7. As discussed previously, in all the embodiments described herein, the shape of occluder **10** may be modified greatly by adjusting the number of elastically deformable members **12** and by changing the arc shape to achieve the best occluding shape for a particular application. In particular, a wider occlusion site may require an occluder **10** such as the one shown in FIG. 6 while a more narrow site may necessitate an occluder **10** having only a slightly bowed shape.

Turning to FIG. 6, FIG. 7, FIG. 8, there are shown embodiments in which elastically deformable members **12** are not secured at their ends. In such embodiments, elastically deformable members **12** may be configured to extend beyond, for instance, clips **14** securing elastically deformable members **12**. If no clips are used, elastically deformable members **12** may extend beyond the location in which securement is achieved. In the embodiment of FIG. 8, occluder **10** includes anchors **18** defined by elastically deformable members **12**. Anchors **18** may be configured to further facilitate (in addition to the arcuate shape of occluder **10**) anchoring to an occlusion site. Although many different formations may serve as anchors, the

illustrated embodiments demonstrate that anchors **18** may comprise a bend in elastically deformable members **12**. Specifically, outer ends of elastically deformable members **12** may be bent back at right angles (or any other suitable angles) in a way to point generally towards each other. As illustrated, only one side of elastically deformable members **12** may include anchors (in FIG. 6, FIG. 7, and FIG. 8 only the top half of occluders **10** have anchors). Although illustrated as integral anchors, anchors **18** may be separate anchors coupled to elastically deformable members **12** by any technique known in the art including, but not limited to, welding, gluing, tying, or the like.

10

FIG. 9 shows occluder **10** including anchors **18** in a semi-compressed state. As illustrated, the ends of elastically deformable members **12** may be configured to flex outward to cover a greater area and to better anchor occluder **10**. FIG. 10 is a top view of an occluder having anchors **18** and demonstrates how the anchors may be spread relative to the body of occluder **10**. Again, depending on the number of elastically deformable members **12** and the extent of its bow shape, the shape of occluder may vary widely. In the illustrated embodiment of FIG. 10, occluder **10** assumes a shape similar to a four leaf clover having smooth transitions from leaf to leaf.

15

Turning now to FIG. 11, there is shown an occluder **10** that includes an occluding agent **20**. Occluding agent **20** may be configured to facilitate quicker occlusion by providing more sites for thrombosis to occur. In one embodiment, occluding agent **20** may be enclosed within jacket **16** of occluder **10**. Any material suitable for facilitating occlusion may be utilized to serve as occluding agent **20**. In one embodiment, one or more threads of polyester may be used. The size and shape of occluding agent **10** may be varied according to need. In one embodiment, only a few polyester fibers may be used as an agent, while in other embodiments, most or all of the interior of an occluder **10** may be filled with an occluding agent such as polyester threads. Occluding agent **20** may advantageously provide for immediate

20

25

30

and complete closure, which, in turn, may prevent hemolysis and bacterial endocarditis.

5 With reference to FIGS. 10-16, the operation of the presently disclosed method and apparatus may be better understood. Looking first to FIG. 12, there is shown an occlusion apparatus 11 including an occluder 10 having a cap 14, elastically deformable members 12, an interdigitated cap 22 having recessed portion 26 and projecting portion 24, an eye 25, and a delivery system 13 having a pushing catheter end 32 that is interdigitated with a recessed portion 30 and a projecting portion 28, 10 and a filament 27. Cap 14 and elastically deformable members 12 may be configured as described herein. Interdigitated cap 22 may be similar to cap 14 except for its shape. Interdigitated cap 22 may be interdigitated as illustrated or otherwise designed so that it may matingly engage a pushing catheter 32.

15 In operation, pushing catheter end 32 may be interlocked with interdigitated cap 22 by inserting projecting portion 28 within recessed portion 26 and by correspondingly inserting projecting portion 24 within recessed portion 30 (see, e.g., FIG. 16 showing an interlocked arrangement). Once interlocked, occluder 10 may be pushed, or pulled by pushing catheter end 32 so that occluder 10 may be positioned, 20 for instance, near an occlusion site. Such a feature advantageously allows for simple repositioning of occluder 10. In one embodiment, to release pushing catheter from occluder 10, pushing catheter end 32 may be lightly flexed laterally. The flexing may release the interlocking portions of cap 22 and pushing catheter end 32 so that occluder 10 may become free. The amount of flexing necessary to release occluder 10 25 may vary with application and may be lessened if occluder 10 is securedly anchored to, for instance, the interior of a vessel. With benefit of the present disclosure, it will be understood that any one of a number of other suitable interlocking techniques known in the art may be substituted for the one illustrated in FIG. 12 and FIG. 13. For example, pushing catheter end 32 may screw into cap 22 (or a cap such as cap 14) 30 to provide for engagement. In other embodiments, pushing catheter end 32 and cap 22 (or cap 14) may be magnetic or electromagnet so that an attractive force (which

may or may not be controllable by varying an electrical current) may be utilized to fix pushing catheter end **32** to cap **22** to allow for two-way positioning (forward and backwards) of occluder **10**.

5           Although shown as exhibiting an interlocking relationship, those of skill in the art will understand, with benefit of the present disclosure, that interlocking or other mating design choices are optional. For instance, in one embodiment, pushing catheter end **32** may not be interdigitated and may be, for example, a smooth cylinder. To move occluder **10** in such an embodiment, pushing catheter end **32** may engage an  
10           end of cap **22** (or, a cap such as the cap **14**) so that occluder **10** may be pushed into a proper position for occlusion. It will be understood that in such an embodiment, only one way positioning of occluder **10** may be possible.

          Eye **25** of occluder **10** of FIG. 12 may be configured to receive filament **27** so  
15           that occluder **10** may be retrieved even when no longer interlocked or associated with pushing catheter end **32**. In particular, filament **27** may be pulled so that occluder **10** may be withdrawn even if occluder **10** has been released from pushing catheter end **32**. As will be discussed below, such a feature advantageously allows for the repositioning of occluder **10**.

20           FIG. 13 shows an occluder **10** and delivery system **13** similar in configuration to those of FIG. 12. The embodiment of FIG. 13 utilizes elastically deformable members **12** secured not at their ends and includes anchors **18** along an upper portion of elastically deformable members **12**. Also, the embodiment of FIG. 13 does not  
25           contain an eye **25**, although it will be understood that an eye may be added.

          FIG. 14 shows an occluder **10** including a cap **14**, elastically deformable members **12**, and interdigitated cap **22**. The delivery system **13** of FIG. 14 shows an interdigitated pushing catheter end **32**, pushing catheter **36**, guide wire **38**, and  
30           guiding catheter **40**. In this illustrated embodiment, a lumen runs through occluder **10** and delivery system **13**. Within this lumen, guide wire **38** may pass. Guide wire **38**



may be configured to guide occluder **10** during deployment from guiding catheter **40**. In particular, guide wire **38** may assure that occluder **10** travels in a straight line to a desired occlusion site. Although it may be made of any suitable material, in one embodiment, guide wire **38** may be constructed from nitinol or stainless steel. Guide wire **38** may have a size that varies widely, but in one embodiment, it may be 0.018-  
5 inches to 0.035-inches. In one embodiment, the surface of guide wire **38** may be treated to modify the coefficient of sliding friction between, for instance, cap **14** and guide wire **38**. The friction may be modified to make sliding along guide wire **38** easier or more difficult, depending upon the desired result. Additionally, guide wire  
10 **38** may be ratcheted so that, for example, the precise motion of occluder **10** may be controlled ratchet by ratchet. With benefit of the present disclosure, those of skill in the art will recognize that guide wire **38** may be configured differently to steer occluder **10** through sliding engagement.

15 Guiding catheter **40** may be configured to enclose occluder **10** when in a compressed-state, as shown in FIG. 15. There, it may be seen that inner walls of guiding catheter **40** may exert a pressure upon an outer surface of elastically deformable members **12**, causing compression into a substantially linear state (see also FIG. 5). In the compressed-state, occluder **10** may be guided within guiding  
20 catheter **40** to reach, for instance, an occlusion site. The size and materials of guiding catheter **40** may vary widely according to application, but in one embodiment, guiding catheter **40** may be constructed of Teflon and may be about 6-French to 8-French OD in diameter.

25 Shown also in FIG. 12 and FIG. 13 is pushing catheter **36**. In one embodiment, and as mentioned earlier, pushing catheter **36** may be configured to engage occluder **10** to move, or slide, occluder **10** relative to guiding catheter **40**. In one embodiment, the engagement may be through an interdigitated pushing catheter end **32** configured to interlockingly mate with cap **22**. In such an embodiment,  
30 motion of occluder **10** relative to guiding catheter **40** may be two ways -- thus, occluder **10** may be deployed or partially deployed by moving occluder **10** forward

(*i.e.* upward in FIG. 12 and FIG. 13) and occluder **10** may be retrieved (and perhaps subsequently repositioned) by sliding occluder **10** backward (*i.e.* downward in FIG. 12 and FIG. 13). In other embodiments, motion of occluder **10** from pushing catheter **36** may be one way. In such an embodiment, pushing catheter end **32** may be flat or  
5 shaped such that engagement with cap **22** (or a cap such as cap **14**) may not be interlocking or may not be stable in more than one direction. The size and materials of pushing catheter **36** may vary widely according to application, but in one embodiment, guiding catheter **36** may be constructed of Teflon, nylon, or any suitable material and may be 4-French to 6-French OD in diameter.

10

In one embodiment, pushing catheter **36** may be replaced by a superelastic nitinol microtubing of similar size with a lumen that may accept a suitable guide wire. In such an embodiment, end **32** may be attached to the distal end of the superelastic nitinol microtubing by any suitable means, and an interdigitating engagement may be  
15 created between end **32** and cap **22**. In yet another embodiment, an integral end **32** may be created as a contiguous portion of a superelastic nitinol microtubing.

Turning to FIG. 16, there is shown a more detailed view of a portion of a delivery system **13** according to one embodiment of the present disclosure. As  
20 illustrated, a guide wire **38** passes through a lumen **44** extending through delivery system **13**. In this embodiment, cap **22** is matingly engaging pushing catheter end **32** *via* interlocking interdigitated surfaces. Pushing catheter **36** may be seen to have a shape suitable for engaging end **32**. In particular, in the illustrated embodiment, pushing catheter **36** is angled corresponding to an angled surface of end **32**. In this  
25 embodiment, pushing catheter **36** is separate from end **32**, and, thus, movement of occluder **10** may be limited to one way motion within guiding catheter **40**. However, in other embodiments, pushing catheter **36** may be integral with end **32** and may be arranged so that two way motion of occluder **10** may be utilized.

30

Turning to FIG. 17, there is shown an embodiment of an occluder apparatus utilizing a stiffening catheter **46**. In this embodiment, stiffening catheter **46** may be

configured to slide relative to guide wire **38**. In particular, stiffening catheter **46** may slidably engage an outer surface of guide wire **38**. In operation, stiffening catheter **46** may engage an end stop **48** of a cap **14** to increase the distance between caps **14** to compress occluder **10**, as may be better seen with reference to FIG. 18. In FIG. 18, it may be seen that cap **14** may include a lumen allowing for passage of guide wire **38**.  
5 The lumen may be narrowed, however, by an end stop **48**, which may be integral with cap **14** or may be coupled thereto by any suitable means known in the art. As illustrated, stiffening catheter **46** may be sized so that it may slide relative to guide wire **38**, but it may not slide past end stop **48**. Rather, stiffening catheter **46** may be slid to contact, and engage end stop **48**. Upon engagement, stiffening catheter **46** may be pushed so that the distance between caps **14** may be increased. Increasing that distance may lead to the generation of compression forces tending to compress occluder **10** into a thinner configuration. Stiffening catheter **46** may thus be used to withdraw a deployed or partially deployed occluder **10** back into, for instance, a guiding catheter **10** so that it may be repositioned at a different occlusion site.  
10  
15

In the embodiment of FIG. 17, it may be seen that occluder **10** and delivery system **13** may be equipped with an eye **25** coupled to a filament **27**. In one embodiment, eye **25** and filament **27** may be used to further increase the distance between caps **14** to further compress occluder **10**. For instance, filament **27** may be pulled while stiffening catheter **46** may be advanced. In such a manner, lower cap **14** may be drawn downward (relative to the illustration of FIG. 15 and FIG. 16) while upper cap **14** may be advanced upward (relative to the illustration of FIG. 15 and FIG. 16) -- thus, the distance between caps **14** may be increase so as to compress occluder **10**.  
20  
25

With reference to FIG. 19, it may be seen how occluder **10** may be used for occluding an occlusion site, the location of which is indicated generally by arrow **17**. In one embodiment, occluder **10** may be brought to occlusion site **17** by first being compressed into a compressed state, such as the state illustrated in FIG. 5. In such a state, occluder **10** may be enclosed within a guiding catheter **40**, as illustrated in FIG.  
30

15. It is contemplated that walls of guiding catheter **40** may serve as the compressing mechanism. In other words, occluder **10** may be inserted into guiding catheter **40**, and the walls of guiding catheter may exert inward forces upon occluder **10**, causing occluder **10** to become compressed so that it may fit within guiding catheter **40**.

5

Once within guiding catheter **40**, occluder **10** may be positioned adjacent occlusion site **17**. As used here, by "adjacent", it is meant that occluder **10** may be positioned in an appropriate location for carrying out the occlusion process. In one embodiment, positioning of occluder **10** may be facilitated through the use of a guide wire **38** illustrated in FIGS. 12-16. In particular, guide wire **38** may be used to precisely locate occlusion site **17**. With guide wire **38** in place, occluder **10** may be deployed along the guide wire, thus ensuring an accurate deployment. Once in position, occluder **10** may be slid relative to guiding catheter **40** so that it may be released. As has been disclosed herein, the sliding may be accomplished by engaging a cap **14** of occluder **10** with a pushing catheter end **32**, attached or coupled to a pushing catheter **36**, as shown in, *e.g.*, FIG. 16. As occluder **10** is slid further, it will eventually exit guiding catheter **40**. While so being deployed, occluder **10**, due to its elastic nature, will recover its arcuate conformation. In particular, as the force from the walls of guiding catheter **40** is removed, elastically deformable members **12** recover their original, bowed shaped, a shape illustrated, for example, in FIG. 1. Again, in one embodiment, occluder **10** may still be coupled to guide wire **38**, even after deployment. In such an embodiment, occluder **10** may use guide wire **38** to lead a direct path to occlusion site **17**. Once securely located at site **17**, guide wire **38** may be removed by sliding guide wire **38** relative to occluder **10** until guide wire **38** no longer engages occluder **10**. Guide wire **38** may then be removed from the area, by, in one embodiment, riding within guiding catheter **40**.

Once fully deployed, occluder **10** may occlude occlusion site **17**, as shown, for instance, in FIG. 19. FIG. 19 illustrates, generally, a vascular occlusion, but with the benefit of the present disclosure those of skill in the art will understand that the present disclosure is not limited vascular occlusion, but rather may be used for any

occlusion application including, but not limited to, ureter occlusions, and the occlusion of patent ductus arteriosus. As illustrated, deployed occluder **10**, having an arcuate shape, may bias (*via* an anchoring force) vessel walls **50** to cause a bulge **52**. In one embodiment, good fixation of occluder **10** within a vessel lumen may correspond with a situation in which the greatest unconstrained diameter of an occluder **10** is about 25%-33% larger than that of the recipient vascular segment, although it is contemplated that other relative size percentages will also suffice to properly anchor occluder **10**. It is also contemplated that such percentages may depend heavily upon the conditions of the site being occluded, and may thus vary widely according to application.

The biasing of walls **50** may lead to the secure anchoring of occluder **10** within the vessel (or, generally, opening) so that migration may be reduced or eliminated. FIG. 20 shows a top view of occluder **10** anchored at occlusion site **17**. As illustrated, outer surfaces of elastically deformable members **12** may conform to substantially match the shape of walls **52**. Further, it may be seen that the elastic nature of elastically deformable members **12** may exert an outward anchoring force that manifests itself as an outward bulge **52**. Again, such an anchoring force may reduce or eliminate migration, and therefore, may reduce or eliminate several problems associated with migration of occluding devices. For instance, the presently disclosed method and apparatus may provide for occlusion that is more permanent in nature reducing the number of return trips a patient must make to a hospital.

Although not illustrated in FIG. 19, the use of anchors **18** (see, *e.g.*, FIG. 6, FIG. 7, and FIG. 8) may further increase the anchoring of occluder **10**, for anchors **18** may grip walls **50** and decrease the chance of any unwanted migration from occlusion site **17**. Although not illustrated in FIG. 19, occluder **10** may be equipped with an occluding agent **20**, as shown in FIG. 11. In one embodiment, occluding agent **20** may include one or more polyester threads, in the form of fuzzy fibers or even forming a bundle that provide additional sites for thrombosis -- the additional sites

may facilitate quicker occlusion of occlusion site **17**, which may, in turn, ensure more precise occlusion at occlusion site **17**.

5 If occlusion may be completed rapidly, there may be a reduced probability that occluder **10** will migrate during the occlusion process. In other words, quick occlusion may itself contribute to quick, successful anchoring of occluder **10**. Quick occlusion has several advantages including a lower probability of distal embolization. If occlusion is taking place too slowly, fragments of soft, fresh thrombi may break off and be carried away with the still-not- arrested blood flow distally to an intended  
10 occlusion site. In high flow conditions (*e.g.*, a-v fistulas, patent ductus arteriosus), partial occlusion may result in hemolysis, which is related to the persistent turbulent flow through the device and which can be a source of complications.

In embodiments described herein, occluders **10** may optionally be retrievable  
15 and repositionable to correct for misplacement errors or to more accurately position an occluder at a specific location. In one embodiment, occluder **10** may be retrieved and repositioned through the use of interdigitated cap **22** and matching interdigitated pushing catheter end **32**, as illustrated, for instance, in FIGS. 10-14. In such an embodiment, pushing catheter **36** may exert bi-directional forces upon occluder **10** *via*  
20 its interlocked coupling with interdigitated cap **22**. As disclosed previously, and as will be appreciated by those of skill in the art, it is contemplated that other mechanisms may serve to bi-directionally couple pushing catheter **36** to occluder **10** other than interdigitating ends, but for convenience the following discussion assumes an interdigitated technique. In this embodiment, pushing catheter **36** may push and  
25 pull occluder **10** within guiding catheter **40** (see FIG. 15).

With reference to FIG. 14, it may be seen how this design may provide for retrieval and repositionability. In FIG. 14, occluder **10** has been deployed from guiding catheter **40**, but has not been released from pushing catheter **36**. In particular,  
30 pushing catheter end **32** is still interlocked with interdigitated end **22** of occluder **10**. In such a position, an operator may release or retrieve occluder **10**. In one

embodiment, the shaft of pushing catheter **36** may be marked to note the position at which interdigitated end **22** will become free of guiding sheath **40** -- such a mark may prevent premature or unexpected deployment of occluder **10**.

5           To release occluder **10**, an operator may slightly flex pushing catheter **36** so as to fully release occluder **10** at an occlusion site (as disclosed earlier, a slight flexing motion may release the interlocking hold of pushing catheter **36** upon occluder **10** by briefly separating the interlocking recesses and projecting portions of end **32** and cap **22**). To retrieve, an operator may pull pushing catheter **36** so as to retrieve occluder  
10 **10** by withdrawing at least a portion of occluder **10** back into guiding catheter **40**. When retrieving, the walls of guiding catheter **40** may exert inward forces upon elastically deformable members **12** so that at least a portion of occluder **10** may become compressed and may fit within guiding catheter **40**. Within, or partially within, guiding catheter **40**, occluder **10** may be repositioned as desired.

15

In another embodiment, occluder **10** may be retrieved by using eye **25** and filament **27** as illustrated in FIG. 10 and FIG. 15. Although not shown, those of skill in the art will recognize that eye **25** may be eliminated by threading filament **27** through cap **14** or by attaching filament **27** in another suitable manner, or to another  
20 suitable location upon occluder **10**. In one embodiment, occluder **10** may be partially or fully withdrawn back into guiding catheter **40** by pulling on filament **27**. This embodiment advantageously allows for retrieval (and repositioning) of occluder **10** even after occluder **10** has been fully deployed and released from pushing catheter **36**, for filament **27**, coupled to occluder **10** by eye **25**, may be pulled even after pushing  
25 catheter **36** has been withdrawn back into guiding catheter **40**. In one embodiment, if retrieval or repositioning is not desired, filament **27** may be removed from eye **25** by cutting filament **27** and by withdrawing it from eye **25**. In other embodiments, cutting may not be necessary -- one end of filament **27** may simply be pulled so as to unthread eye **25**.

30

In one embodiment, both an eye/filament technique and an interlocking pushing catheter technique may be used in combination to facilitate retrieval and repositioning. Additionally, stiffening catheter **46** (see FIG. 15 and FIG. 16) may be utilized in any of the disclosed embodiments to aid in retrieval and/or repositioning.

5 In one embodiment, stiffening catheter **46** may be advanced to engage end stops **48** so as to compress occluder **10**. The compression of occluder **10** may, in turn, simplify the withdrawal of occluder **10** back into guiding catheter **40** during a retrieval and/or repositioning procedure.

10 Turning to FIG. 19 and FIG. 20, there is shown a particular application for the presently disclosed method and apparatus -- closure of patent ductus arteriosus. FIG. 19 and FIG. 20 show the anatomy of patent ductus arteriosus. In particular, an aortic arch **66** having a brachiocephalic artery **72**, a left carotid artery **70**, a left subclavian artery **68**, a left pulmonary artery **62**, and a descendent aorta **64** may be seen. Patent  
15 ductus arteriosus (PDA), illustrated by arrow **60** refers to the condition, well known in the art, of an abnormal persistence of an open lumen between the descendent aorta and the pulmonary artery. The direction of blood flow is directed from the aorta (higher pressure) to the pulmonary artery resulting in recirculating of arterial blood through the lungs as well as pulmonalis arterial hypertension.

20

In FIG. 21, PDA **60** may be closed using an occluder **10** in accordance with any of the embodiments of the present disclosure, and more particularly with an embodiment utilizing a guide wire **38**. Occluder **10** may be positioned adjacent an occlusion site corresponding to PDA **60**. Occluder **10** may be deployed (and retrieved  
25 and repositioned) so that occlusion may occur. In one embodiment, a guide wire **38** may aid in the precise deployment of occluder **10**. In one embodiment, a femoral vein approach may be utilized in which occluder **10** may be deployed from the pulmonary artery **62**. In the embodiment of FIG. 21, it may be seen that elastically deformable members **12** may form legs that may be deployed before the body of occluder **10**.  
30 These legs may be equipped with anchors **18** to further aid in anchoring occluder **10**. In one embodiment, legs may be arranged around a circumference of an aortic ostium.



However, it will be understood that an occluder **10** without legs, such as the occluder **10** illustrated in FIG. 1, may likewise be used to close PDA **60**.

In FIG. 22, PDA **60** may be closed with an occluder **10** having elastically  
5 deformable members **12** extending from both sides of the body of occluder **10** and  
having anchors **18**. The legs and anchors **18** may aid in securedly anchoring occluder  
**10** about PDA **60**. As discussed above, in one embodiment, occluder **10** may be  
deployed from pulmonary artery **62**. In both the embodiments of FIG. 19 and  
FIG. 20, those of skill in the art will recognize that that size and shape of occluder **10**  
10 may be modified so as to best fit PDA **160**.

With the benefit of the present disclosure, those of skill in the art will  
understand that the applications for the method and apparatus described herein are  
vast. For example, the disclosed occluders may be used in veins and non tapered  
15 vascular territories where the possibility of migration is high. High flow vascular  
lesions including arterio-venous malformations and fistulas may be one of the  
possible applications of the occluders both in lesions of the extremities and the lungs.

Chronic pseudoaneurysms may also be safely excluded from the circulation  
20 using the occluders described herein. Occluders described herein may also play a role  
in the non-surgical management of patients with systemic to pulmonary collateral  
vessels and shunts. The same holds true for the embolization treatment of coronary  
artery fistulas.

25 The occluders may also be used for embolization without migration on the  
venous side (*e.g.*, for the treatment of varicoceles, or of aberrant vessels). This  
indication is supported by the fact that the detachable balloons are not recommended  
to be used for this purpose any longer.

30 As mentioned earlier, the presently disclosed method and apparatus may be  
particularly well suited for ureter occlusion. In particular, the presently disclosed

occluders may cause a prompt and reliable ureteral occlusion without the need for injecting other embolic agent(s) to complete the obstruction. Migration of the device may be prevented by the self anchoring mechanism, and the occluder may be made in a repositionable form. From a technological and economical viewpoint, the disclosed  
5 occluders are also advantageous in that they may also be used for vascular occlusion. In fact, the only difference between the two applications may be covering material of the jacket.

The following examples are included to demonstrate specific embodiments of  
10 the invention. It should be appreciated by those of skill in the art that the techniques disclosed in the examples which follow represent techniques discovered by the inventors to function well in the practice of the invention, and thus can be considered to constitute specific embodiments for its practice. However, those of skill in the art should, in light of the present disclosure, appreciate that many changes can be made in  
15 the specific embodiments which are disclosed and still obtain a like or similar result without departing from the spirit and scope of the invention.

### **EXAMPLES**

20 To achieve quick, limited-size vascular occlusion, a self-expanding, self-anchoring basket-shaped vascular occlusion device has been designed and fabricated. Studies have been performed demonstrating occluders 10 in accordance with the present disclosure in a high-flow arterial model.

#### 25 *Device Construction*

Devices of varying size have been constructed from four 0.009 inch nitinol wires held together at each end by a stainless steel clip. Nitinol, an alloy composed of 55% nickel and 45% titanium with a titanium-oxide layer, has been used because of its shape memory properties and established biocompatibility (Liu and Stice, 1990;  
30 Castleman *et al.*, 1976). The disclosed occluder configuration has been achieved by pushing the two ends of the wire frame toward each other and then heating the device

to 500°C for 120 min. After allowing the device to cool to room temperature, a bead of silver solder was placed around each steel clip for reinforcement.

5 An elastic Dacron jacket, formed by heat sealing the edges, has been pulled over the metallic frame and attached at one end to the steel clip with 5-0 Prolene monofilament suture (Ethicon, Sommerville, NJ). Small bundles of polyester threads have been placed within the Dacron jacket before attaching the open end to the other steel clip. In smaller occluders, polyester threads have been twisted together to form a compact bundle centered within the nitinol frame. In occluders used for aortic  
10 occlusion, polyester threads have formed a loose bundle that filled the space within the Dacron jacket.

#### *Animal Testing*

15 Three occluders that did not contain polyester threads were placed in the common iliac arteries of 2 domestic pigs (one device per artery). Subsequently, 14 devices containing polyester threads were placed in 10 common iliac arteries and 4 abdominal aortas of 5 domestic pigs.

20 The animals were fasted for 18 h before each procedure. Each pig was sedated with an i.m. injection of solution containing ketamine hydrochloride (15 mg/kg), acepromazine (0.15 mg/kg), and atropine sulfate (0.04 mg/kg). Anesthesia was induced with isoflurane (5%) administered *via* a mask. Once the pig was anesthetized, an endotracheal tube was inserted and anesthesia was maintained with isoflurane (1.5%), nitrous oxide (0.3 L/min), and oxygen (0.8 L/min).

25

A carotid artery was surgically isolated, an 8-F Flexor sheath (Cook Inc., Bloomington, IN) was introduced through a small arteriotomy, and sodium heparin (100 IU/kg) was given. Under fluoroscopic monitoring, the sheath was positioned in an iliac artery or the infrarenal portion of the abdominal aorta and angiography was  
30 performed through the sheath. An occluder was loaded into a 10.5-F OD stainless steel metal cartridge and then pushed from the cartridge directly into the previously

placed Flexor sheath with the stiff end of an 0.052 inch guidewire equipped with a 0.092 inch guidewire piece. The occluder was advanced to the end of the sheath with the dilator, and while holding the dilator against the occluder, the sheath was withdrawn releasing the occluder into the vessel.

5

Hand injections of contrast were made under fluoroscopic observation at one minute intervals to determine the time required for complete vascular occlusion. When complete obliteration of the vascular lumen was seen fluoroscopically, an arteriogram was obtained to confirm the occlusion.

10

One hour after placement, the animal was sacrificed with an intravenous overdose (1.0 ml/10 lb of body weight) of Beuthanasia D (Schering-Plough Animal Health Corp.; Kenilworth, NJ), and a complete necropsy was performed.

## 15 *RESULTS*

The occluders were easy to deliver with good precision. Deployment of the occluders was smooth and continuous; none jumped from the end of the sheath when released. The occluders readily assumed their pre-programmed unconstrained diameter, and symmetrical positioning of the occluders was achieved in all but one case. One occluder placed in an aorta opened asymmetrically because the clip at one end failed to hold the nitinol wires together without movement.

20

Radiographically, the three occluders lacking polyester threads produced only partial vascular occlusion after one hour. Placement of the occluders containing polyester threads resulted in complete vascular occlusion of all iliac arteries and three of four abdominal aortas. The time required for complete common iliac occlusion was 2-8 min (median 5 min). Complete aortic occlusion occurred in 8, 13, and 16 min. respectively. Sixty minutes after deployment of the device that opened asymmetrically, only partial aortic occlusion was noted.

25

30

Necropsy revealed firm contact between the occluder and the vessel wall in all cases indicating effective anchoring of the device. The presence of firm contact was corroborated grossly by multiple indentations on the luminal surface caused by the nitinol wires.

5

Soft clot was found on the Dacron jackets of all occluders. A small amount of thrombus was found on the inside of the Dacron covering in the devices that did not contain polyester threads. A large amount of compact clot was found within the jacket of each basket containing threads. In some vessels, additional soft clot of limited size was also observed adjacent to the cephalad and/or caudad ends of the occluder.

10

While the present disclosure may be adaptable to various modifications and alternative forms, specific embodiments have been shown by way of example and described herein. However, it should be understood that the present disclosure is not intended to be limited to the particular forms disclosed. Rather, it is to cover all modifications, equivalents, and alternatives falling within the spirit and scope of the disclosure as defined by the appended claims. For instance, the disclosed apparatus may utilize different orientations of components, sizes of components, or materials according to needs. Moreover, the different aspects of the disclosed methods and apparatuses may be utilized in various combinations and/or independently. Thus the invention is not limited to only those combinations shown herein, but rather may include other combinations. In other words, those of skill in the art should, in light of the present disclosure, appreciate that many changes can be made in the specific embodiments that are disclosed and still obtain a like or similar result without departing from the spirit and scope of the invention.

15

20

25

REFERENCES

- The following references, to the extent that they provide exemplary procedural or other details supplementary to those set forth herein, are specifically incorporated herein by reference.
- 5 Bing, Hicks, Figenshau, Wick M, Picus D, Darcy MD, Clayman RV. "Percutaneous ureteral occlusion with use of Gianturco coils and gelatine sponge, Part I. Swine model" *JVIR*; 3:313-317, 1992 (a)
- Bing, Hicks, Picus, Darcy. "Percutaneous ureteral occlusion with use of Gianturco coils and gelatine sponge, Part II. Clinical Experience," *JVIR*; 3:319-321, 10 1992 (b)
- Cambier, Kirby, Wortham, Moore, "Percutaneous closure of the small (<2.5 mm) patent ductus arteriosus using coil embolization," *Am. J. Cardiol.*, 69:815-816, 1992.
- 15 Castleman, Motzkin, Alicandri, Bonawit, "Biocompatibility of nitinol alloy as an implant material," *J. Biomed. Mater. Res.*, 10:695 731, 1976.
- Dutton, Jackson, Hughes *et al.*, "Pulmonary arteriovenous malformations: results of treatment with coil embolization in 53 patients," *AJR*, 165:1119 1125, 1995.
- Furuse, Iwasaki, Yoshino, Konishi, Kawano, Kinoshita, Ryu, Satake, Moriyama, 20 "Hepatocellular carcinoma with portal vein tumor thrombus: embolization of arterioportal shunts," *Radiology*, 204:787 790, 1997.
- Gianturco, Anderson, Wallace, "Mechanical device for arterial occlusion," *AJR*, 124:428 435, 1975.
- Grifka, Vincent, Nihill, Ing, Mullins, "Transcatheter patent ductus arteriosus closure 25 in an infant using the Gianturco Grifka vascular occlusion device," *Am. J. Cardiol.*, 78:721 723, 1996.
- Guglielmi, Vinuela, Duckwiler, Dion, Stocker, "Highflow. small-hole arteriovenous fistulas: treatment with electrodetachable coils." *AJNR*, 16:325 328, 1995.
- Hendrickx, Orth, Grunert, "Long-term survival after embolization of potentially lethal 30 bleeding malignant pelvic turnouts," *Br. J. Radial.*, 68:1336 1343, 1995.

- Hijazi and Geggel, "Results of anterograde transcatheter closure of patent ductus arteriosus using single or multiple Gianturco coils," *Am. J. Cardiol.*, 74:925-929, 1994.
- Hijazi and Geggel, "Transcatheter closure of patent ductus arteriosus using coils," *Am. J. Cardiol.*, 79:1279-1280, 1997.
- 5 Hosking, Benson, Musewe, Dyck, Freedom, "Transcatheter occlusion of the persistently patent ductus arteriosus," *Circulation*, 84:2313-2317, 1991.
- Kónya, Wright, Wallace, "Anchoring coil embolization in a high-flow arterial model," *JVIR*, 9:249-254, 1998.
- 10 Krichenko, Benson, Burrows, Moes, McLaughlin, Freedom, "Angiographic classification of the isolated, persistently patent ductus arteriosus and implications for percutaneous catheter occlusion," *Am. J. Cardiol.*, 63:877-880, 1989.
- Latson, "Residual shunts after transcatheter closure of patent ductus arteriosus," *Circulation*, 84:2591-2593, 1991.
- 15 Levey, Teitelbaum, Finck, Pentecost, "Safety and efficacy of transcatheter embolization of axillary and shoulder arterial injuries," *JVIR*, 2:99-104, 1991.
- Liu and Stice, "Shape memory alloys and their applications," *J. Appl. Manufact. Sys.*, 3:65-72, 1990.
- 20 Lloyd, Fedderly, Mendelsohn, Sandhu, Beekman, "Transcatheter occlusion of patent ductus arteriosus with Gianturco coils," *Circulation*, 88:1412-1420, 1993.
- Magal, Wright, Duprat, Wallace, Gianturco, "A new device for transcatheter closure of patent ductus arteriosus: a feasibility study in dogs," *Invest. Radiol.*, 24:272-276, 1989.
- 25 Marks, Chee, Liddel, Steinberg, Panahian, Lane, "A mechanically detachable coil for the treatment of aneurysms and occlusion of blood vessels," *AJNR*, 15:821-827, 1994.
- Masura, Walsh, Thanopoulous, Chan, Bass, Gousous, Gavora, Hijazi, "Catheter closure of moderate to large sized patent ductus arteriosus using the new Amplatz duct occluder: immediate and short term results," *J. Am. Coll. Cardiol.*, 31:878-882, 1998.
- 30

- Menachem, Coldwell, Young, Burgess, "Hemorrhage associated with pelvic fractures: causes, diagnosis, and emergent management," *AJR*, 157:1005 1014, 1991.
- Nancarrow, Fellows, Lock, "Stability of coil emboli: an *in vitro* study," *Cardiovasc. Intervent. Radiol.*, 10:226 229, 1987.
- 5 O'Halpin, Legge, MacErlean, "Therapeutic arterial embolization: report of five years' experience," *Clin. Radiol.*, 354:85 93, 1984.
- Pozza, Gomes, Qian, Ambrozaitis, Kim, Amplatz, "Transcatheter occlusion of patent ductus arteriosus using a newly developed self-expanding device: evaluation in a canine model," *Invest. Radiol.*, 30:104 109, 1995.
- 10 Punekar, Prem, Ridhorkar, Deshmukh, Kelkar, "Post-surgical recurrent varicocele: efficacy of internal spermatic venography and steel-coil embolization," *Br. J. Urol.*, 77:12-128, 1996.
- Rashkind, Mullins, Hellenbrand, Tait, "Nonsurgical closure of patent ductus arteriosus: clinical application of the Rushkind PDA occluder system,"
- 15 *Circulation*, 75:583-592, 1987.
- Reidy and Qureshi, "Interlocking detachable platinum coils, a controlled embolization device: early clinical experience," *Cardiovasc. Intervent. Radiol.*, 19:85 90, 1996.
- Sagara, Miyazono, Inoue, Ueno, Nishida, Nakajo, "Recanalization after coil
- 20 embolotherapy of pulmonary arteriovenous malformations: study of long term outcome and mechanism for recanalization," *AJR*, 170:727 730, 1998.
- Schild, Mildemberger, Kerjes, "Effectiveness of platinum wire microcoils for venous occlusion: a study on patients treated for venogenic impotence," *Cardiovasc. Intervent. Radiol.*, 17:170 172, 1994.
- 25 Schmitz Rode, Timmermans, Uchida, Kichikawa, Hishida, Gunther, Rosch, "Self-expandable spindle for transcatheter vascular occlusion: *in vivo* experiments," *Radiology*, 188:95 100, 1993.
- Schwartz, Teitelbaum, Kantz, Pentecost, "Effectiveness of transcatheter embolization in the control of hepatic vascular injuries," *JVIR*, 4:359 365, 1993.
- 30 Selby Jr., "Interventional radiology of trauma," *Radiol. Clin. N. Am.*, 30:427 439, 1992.



- Sharaffuddin, Gu, Cervera Ceballos, Urness, Amplatz. "Repositionable vascular occluder: experimental comparison with standard Gianturco coils," *JVIR*, 7:695 703, 1996.
- 5 Sharafuddin, Gu, Titus, Sakinis, Pozza, Coleman, Cervera-Ceballos, Aideyan, Amplatz, "Experimental evaluation of a new self expanding patent ductus arteriosus occluder in a canine model," *JVIR*, 7:877 887, 1996.
- Sommer, Gutierrez, Lai, Parness, "Use of preformed nitinol snare to improve transcatheter coil delivery in occlusion of patent ductus arteriosus," *Am. J. Cardiol.*, 74:836 839, 1994.
- 10 Teitelbaum, Reed, Larsen, Lee, Pentecost, Finck, Katz, "Microcatheter embolization of non-neurologic traumatic vascular lesions," *JVIR*, 4:149 154, 1993.
- Tometzki, Arnold, Peart *et al.*, "Transcatheter occlusion of the patent ductus arteriosus with Cook detachable coils," *Heart*, 76:531 535, 1996.
- "Transcatheter occlusion of persistent arterial duct." Report of the European Registry, *Lancet*, 340:1062 1066, 1992.
- 15 Uzun, Hancock, Parsons, Dickinson, Gibbs, "Transcatheter occlusion of the arterial duct with Cook detachable coils: early experience," *Heart*, 76:269 273, 1996.
- Vedantham, Goodwin, McLucas, Mohr, "Uterine artery embolization: an underused method of controlling pelvic hemorrhage," *Am. J. Obstet. Gynecol.*, 176:938 948, 1997.
- 20 Wallace, Granmayeh, deSantos, Murray, Romsdahl, Bracken, Jonsson, "Arterial occlusion of pelvic bone tumors," *Cancer*, 43: 322 328, 1979.
- Wessel, Keane, Parness, Lock, "Outpatient closure of the patent ductus arteriosus," *Circulation*, 77:1068 1071, 1988.
- 25 White, Pollak, Wirth, "Pulmonary arteriovenous malformations: diagnosis and transcatheter embolotherapy," *JVIR*, 7:787 804, 1996.
- Zubillaga, Guglielmi, Vinuela, Duckwiler, "Endovascular occlusion of intracranial aneurysms with electrically detachable coils: correlation of aneurysm neck size and treatment results," *AJNR*, 15:815820, 1994.

**CLAIMS:**

1. An occluder comprising:
  - 5 a plurality of elastically deformable members secured in spaced relation and extending in arcuate conformation therebetween, said plurality of elastically deformable members operable to become compressed upon application of a force and to recover said arcuate conformation upon removal of said force; and
  - 10 a jacket in operable relation to said plurality of elastically deformable members and configured to cover at least a portion of said plurality of elastically deformable members.
- 15 2. The occluder of claim 1, wherein said plurality of elastically deformable members are programmed with thermal memory.
3. The occluder of claim 1, wherein said plurality of elastically deformable members are programmed with superelasticity.
- 20 4. The occluder of claim 1, wherein said plurality of elastically deformable members are secured at their ends.
5. The occluder of claim 1, further comprising one or more anchors defined by one or more ends of said plurality of elastically deformable members.
- 25 6. The occluder of claim 1, further comprising a pair of clips in spaced relation for securing said plurality of elastically deformable members.
7. The occluder of claim 6, wherein at least one of said clips is interdigitated.
- 30 8. The occluder of claim 6, further comprising an eye in operable relation to at least one of said clips.

9. The occluder of claim 1, wherein said jacket comprises dacron.
10. The occluder of claim 1, wherein said jacket comprises polyurethane.
- 5 11. The occluder of claim 1, wherein said plurality of elastically deformable members comprises four or more nitinol wires.
12. The occluder of claim 1, further comprising an occluding agent enclosed within  
10 said jacket.
13. The occluder of claim 12, wherein said occluding agent comprises one or more threads of polyester.
- 15 14. An occlusion system comprising:  
an occluder comprising:  
a pair of clips configured in spaced relation;  
a plurality of elastically deformable wires secured by said clips and  
extending in arcuate conformation therebetween, said plurality  
20 of elastically deformable wires operable to become compressed upon application of a force and to recover said arcuate conformation upon removal of said force;  
a jacket in operable relation to said plurality of elastically deformable  
wires and configured to cover at least a portion of said plurality  
25 of elastically deformable wires; and  
a delivery system comprising:  
a guiding catheter configured to receive said occluder, said guiding  
catheter compressing and guiding said plurality of elastically  
deformable wires; and  
30 a pushing catheter configured to engage at least one of said pair of clips to slide said occluder relative to said guiding catheter.

15. The system of claim 14, wherein said plurality of elastically deformable wires comprise four, five, or six nitinol wires.
- 5 16. The system of claim 14, wherein said plurality of elastically deformable wires are programmed with thermal memory.
17. The system of claim 14, wherein said plurality of elastically deformable wires are programmed with superelasticity.
- 10 18. The system of claim 14, wherein said occluder further comprises one or more anchors defined by one or more ends of said plurality of elastically deformable wires.
19. The system of claim 14, wherein said jacket comprises dacron.
- 15 20. The system of claim 14, wherein said jacket comprises polyurethane.
21. The system of claim 14, wherein said occluder further comprises an occluding agent enclosed within said jacket.
- 20 22. The system of claim 21, wherein said occluding agent comprises one or more threads of polyester.
23. The system of claim 14, wherein said occluder further comprises an eye in operable relation to at least one of said clips and wherein said delivery system further comprises a retrieval filament configured to engage said eye to retrieve said occluder.
- 25 24. The system of claim 14, wherein at least one of said clips is an interdigitated clip.
- 30 25. The system of claim 24, wherein an end of said pushing catheter is interdigitated and configured to removably interlock with said interdigitated clip.

26. The system of claim 14, further comprising a lumen defined through said occluder and said delivery system.
- 5 27. The system of claim 26, wherein said delivery system further comprises a guide wire within said lumen and passing through an interior of said occluder.
28. The system of claim 27, wherein said delivery system further comprises a stiffening catheter configured to engage at least one of said clips to compress said  
10 occluder.
29. A method for occluding an occlusion site, comprising:
- 15 providing an occluder including a pair of clips configured in spaced relation, a plurality of elastically deformable wires secured by said clips and extending in arcuate conformation therebetween, and a jacket in operable relation to said plurality of elastically deformable wires;
  - providing a delivery system including a guiding catheter configured to receive said occluder and a pushing catheter configured to engage at least one of said pair of clips;
  - 20 positioning said guiding catheter adjacent said occlusion site, wherein said occluder is positioned within said guiding catheter;
  - engaging at least one of said pair of clips with said pushing catheter; and
  - sliding said occluder relative to said guiding catheter with said pushing catheter so as to deploy said occluder from said guiding catheter so as  
25 to recover said arcuate conformation to occlude said occlusion site.
30. The method of claim 29, wherein said occluder further comprises one or more anchors defined by one or more ends of said plurality of elastically deformable wires, and wherein said method further comprises anchoring said occluder at said occlusion  
30 site with said one or more anchors.

31. The method of claim 29, wherein at least one of said clips is an interdigitated clip, wherein an end of said pushing catheter is interdigitated, and wherein the method further comprises retrieving said occluder by interlocking said interdigitated clip with said interdigitated end of said pushing catheter by drawing at least a portion of said occluder within said guiding catheter.
32. The method of claim 31, further comprising repositioning said guiding occluder.
33. The method of claim 29, wherein said occluder and delivery system further comprise an eye in operable relation to at least one of said clips and a retrieval filament configured to engage said eye, and wherein said method further comprises retrieving said occluder by drawing at least a portion of said occluder within said guiding catheter with said retrieval filament.
34. The method of claim 33, further comprising repositioning said occluder.
35. The method of claim 29, wherein said occluder further comprises a lumen defined through said occluder and a guide wire configured to pass within said lumen, and wherein said method further comprises guiding said occluder toward said occlusion site with said guide wire.
36. The method of claim 29, wherein said delivery system further comprises a stiffening catheter configured to engage at least one of said clips, and wherein said method further comprises engaging said at least one of said clips with said stiffening catheter and compressing said occluder with said stiffening catheter by increasing the distance between said pair of clips.
37. The method of claim 29, wherein said occlusion site is a vascular occlusion site.
38. The method of claim 29, wherein said occlusion site is a ureter occlusion site.

39. The method of claim 29, wherein said occlusion site is a patent ductus arteriosus site.

40. A method for closure of patent ductus arteriosus having an aortic and pulmonary side, comprising:

- 5 providing an occluder including a pair of clips configured in spaced relation, a plurality of elastically deformable wires secured by said clips and extending in arcuate conformation therebetween, and a jacket in operable relation to said plurality of elastically deformable wires;
- 10 providing a delivery system including a guiding catheter configured to receive said occluder and a pushing catheter configured to engage at least one of said pair of clips;
- positioning said guiding catheter adjacent said patent ductus arteriosus, wherein said occluder is positioned within said guiding catheter; and
- 15 deploying said occluder from said guiding catheter so as to recover said arcuate conformation to close said patent ductus arteriosus.

41. The method of claim 40, wherein said occluder further comprises a guide wire in operable relation to said guiding catheter, and wherein said method further comprises

20 guiding said occluder toward said patent ductus arteriosus with said guide wire.

42. The method of claim 40, wherein positioning comprises positioning said occluder on said pulmonary side.

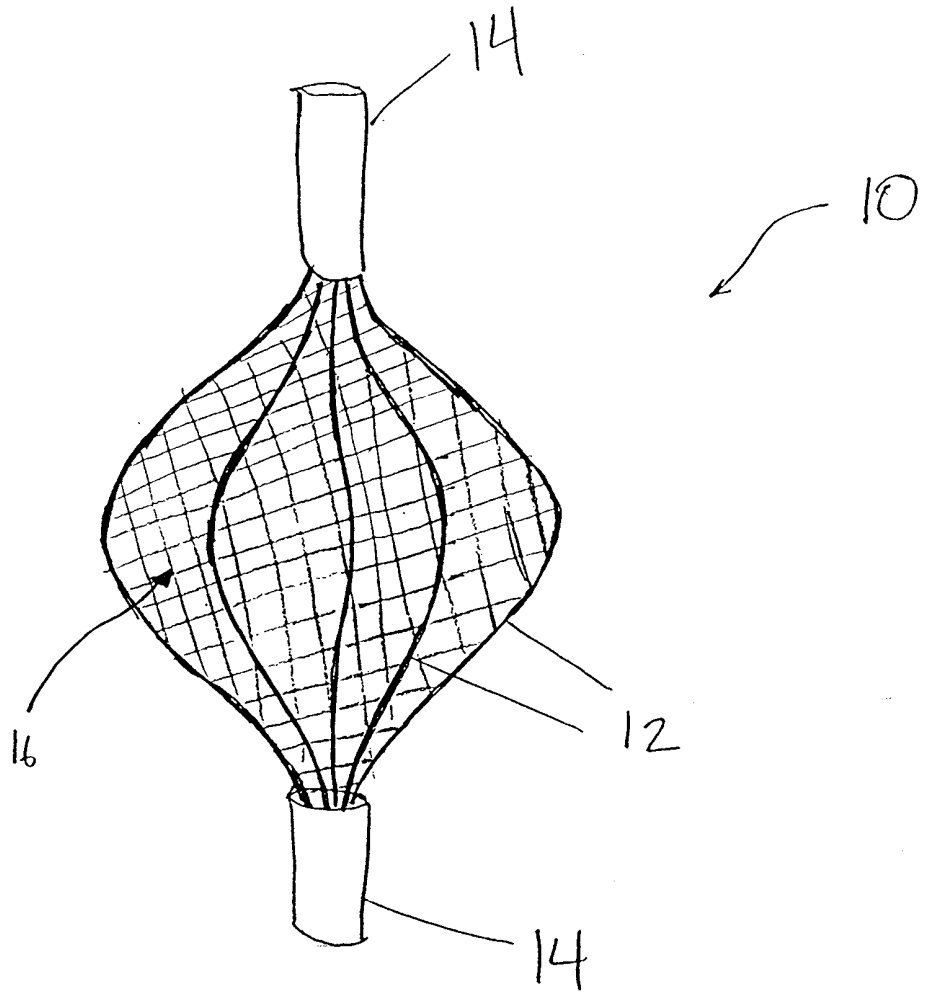

FIG. 1



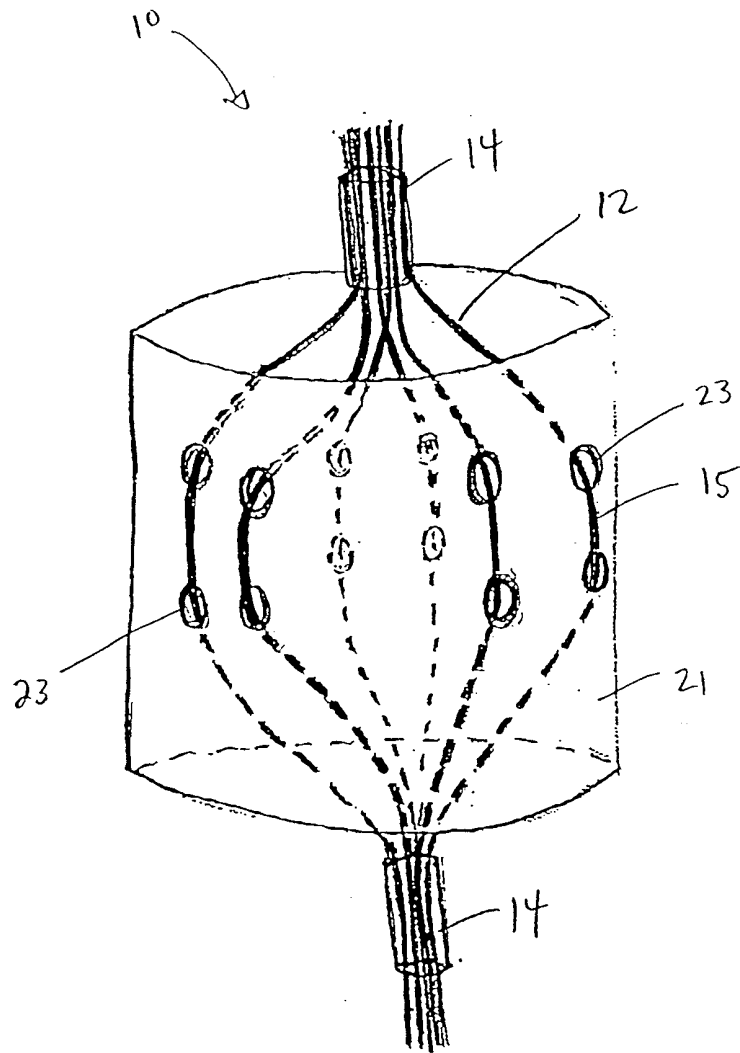

FIG. 2

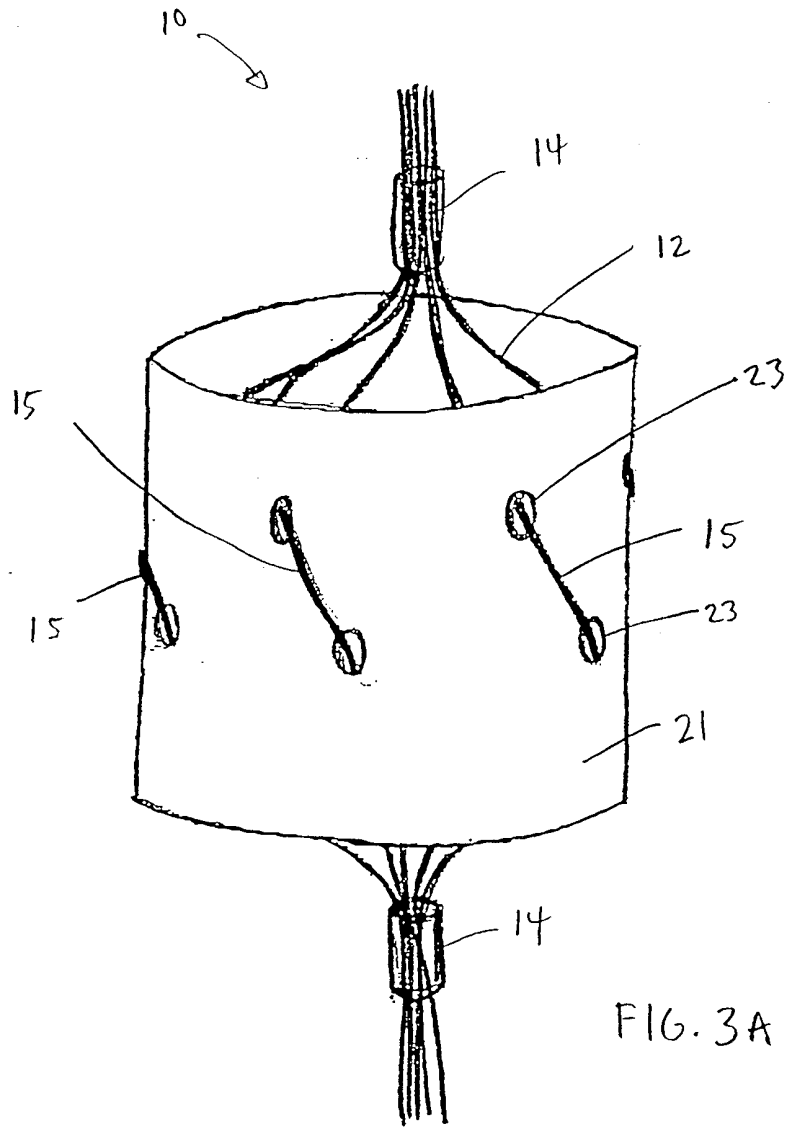

FIG. 3A

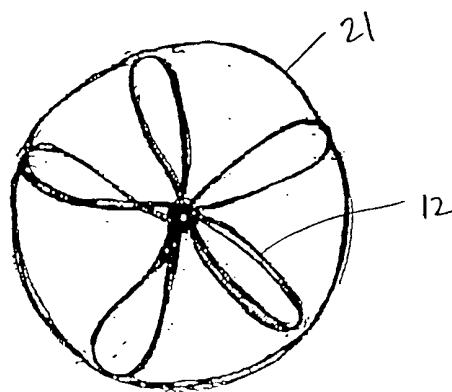

FIG. 3B

10  
↙

10  
↙

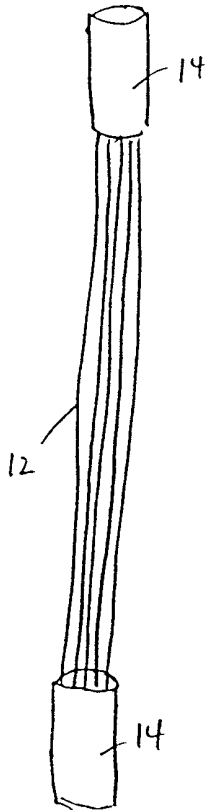

FIG. 5

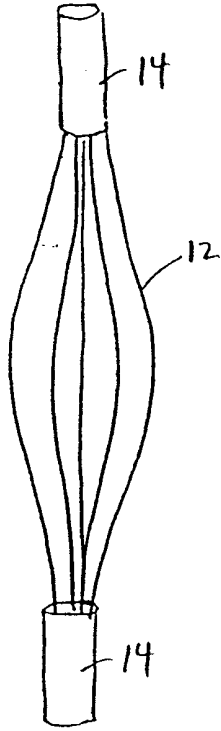

FIG. 4

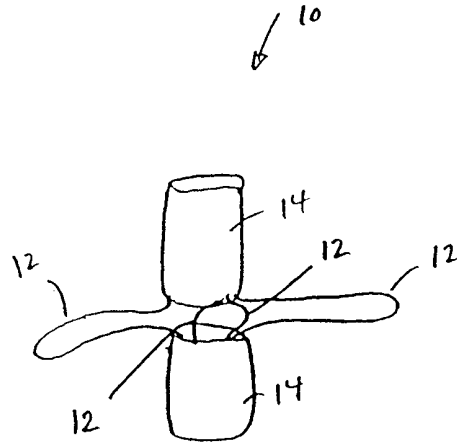

FIG. 6

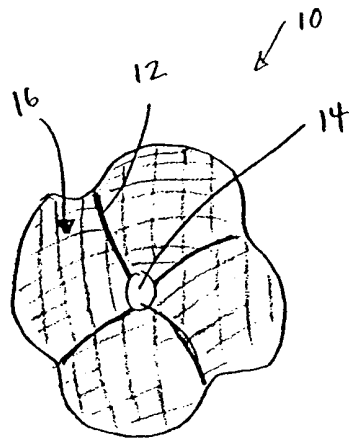

FIG. 7

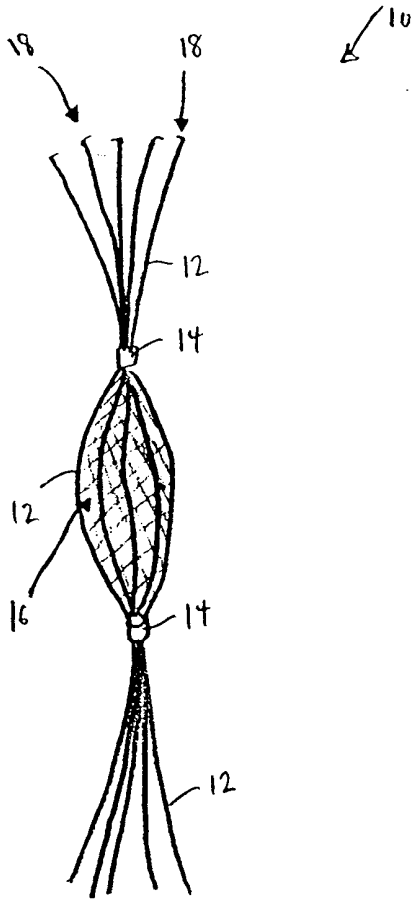

FIG. 8

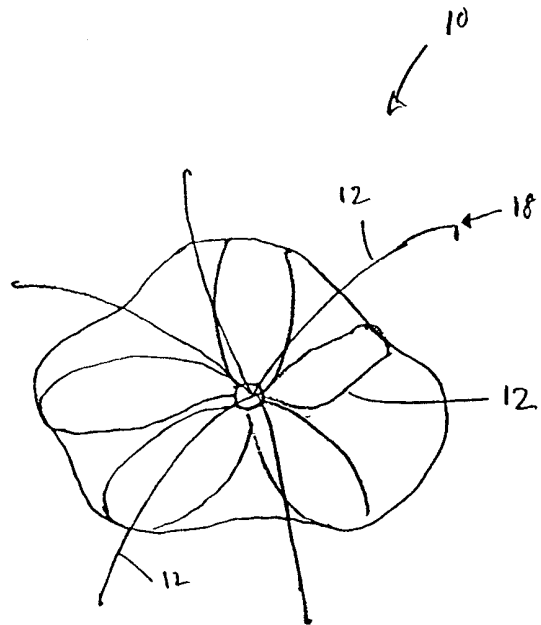

FIG. 10

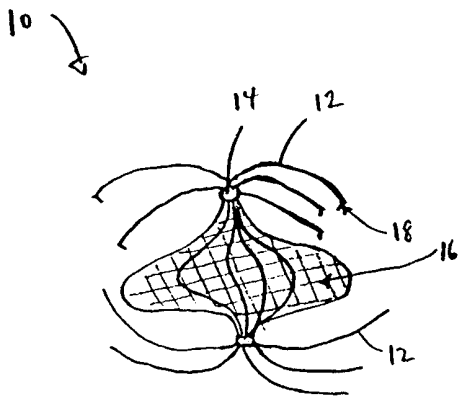

FIG. 9

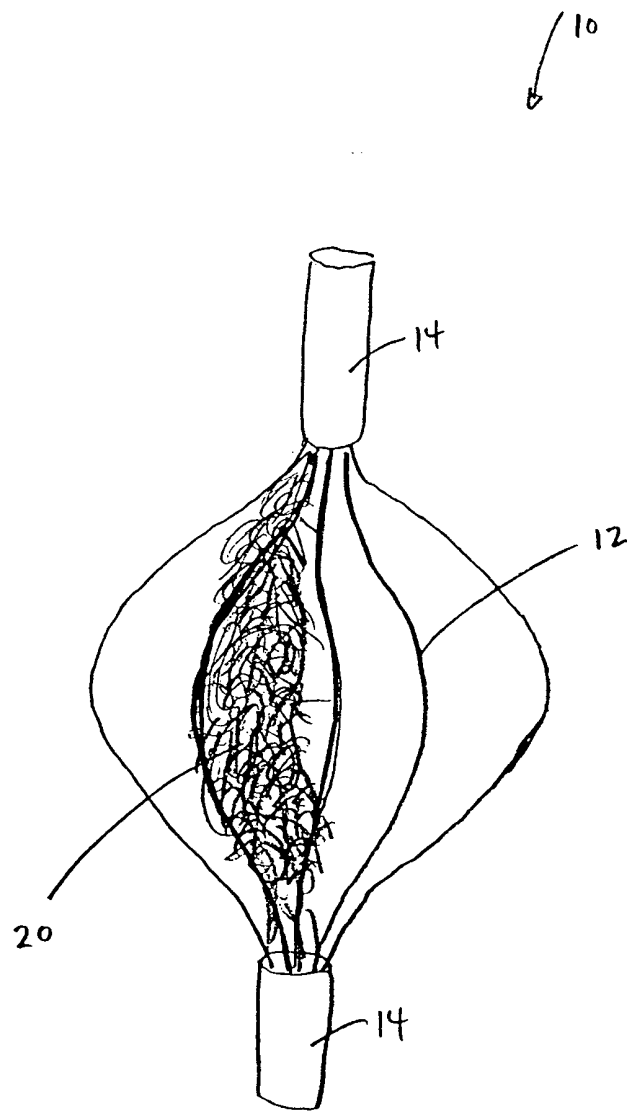
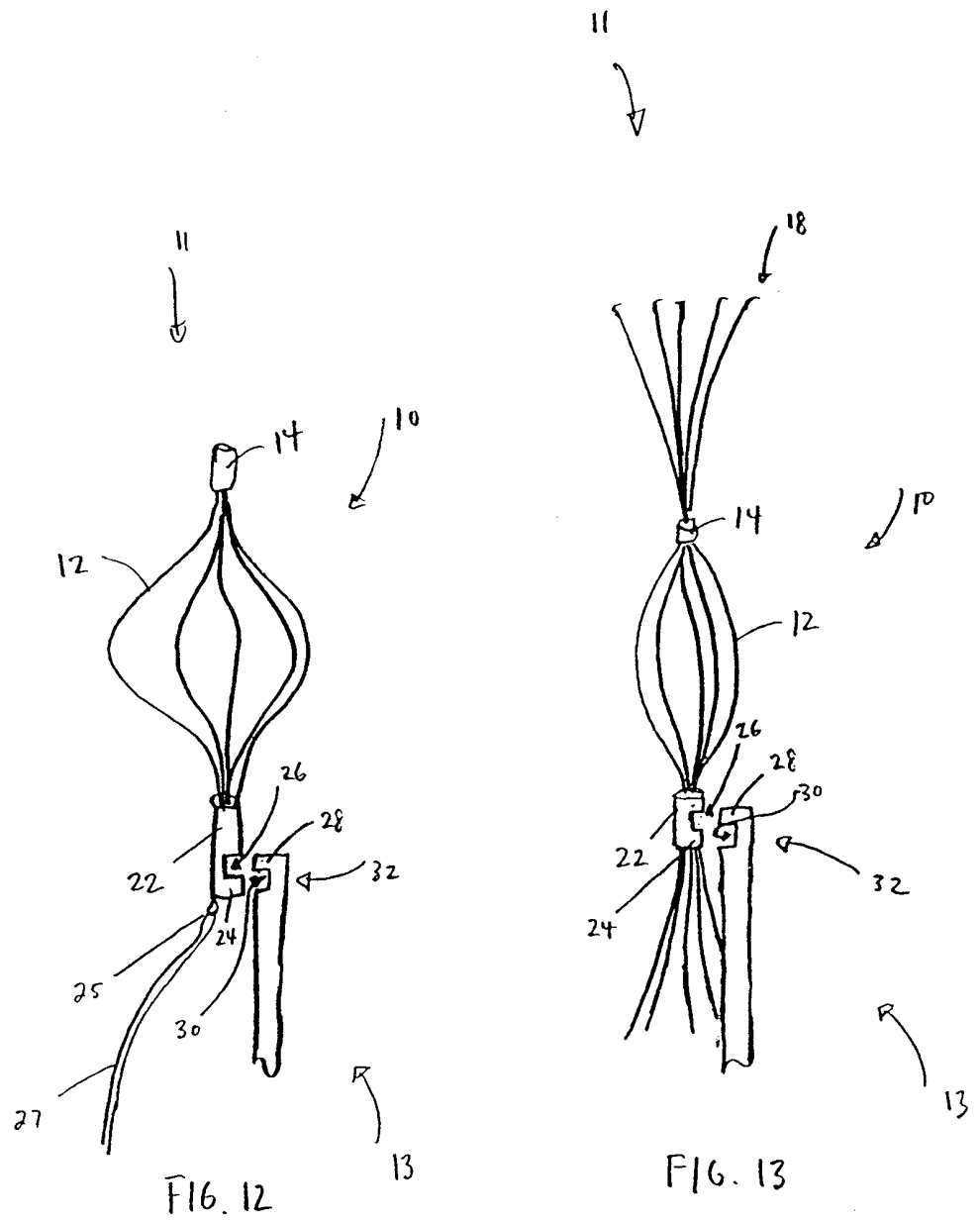

FIG. 11



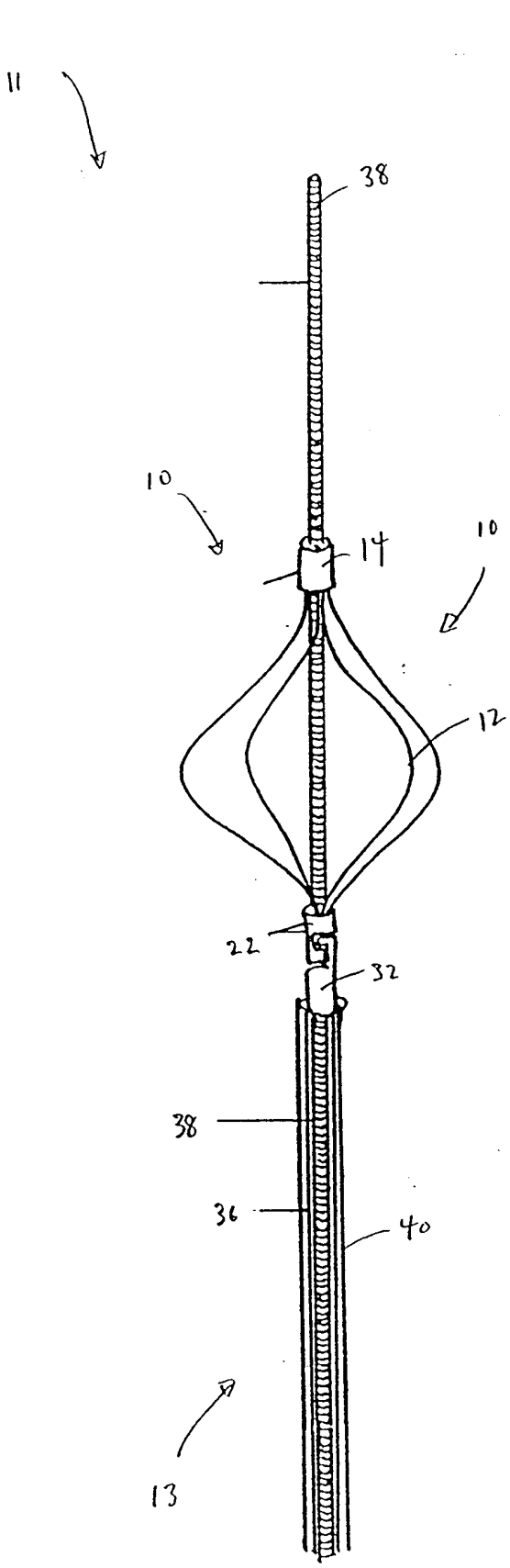

FIG. 14 9/14

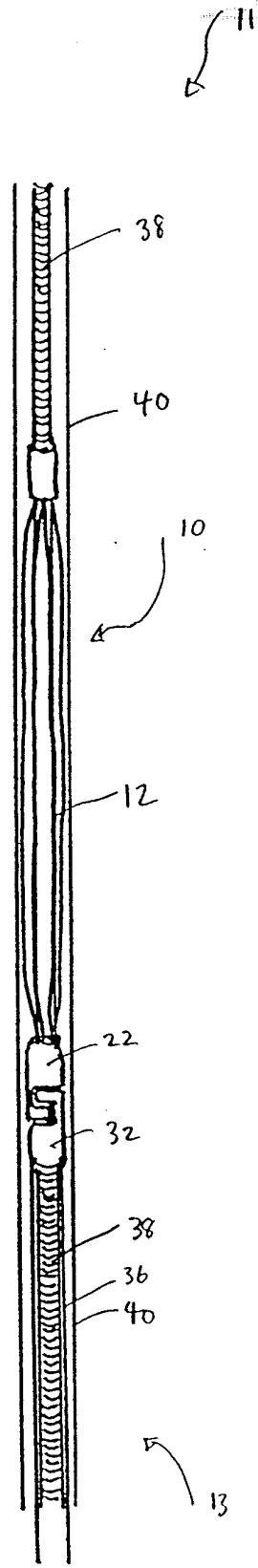
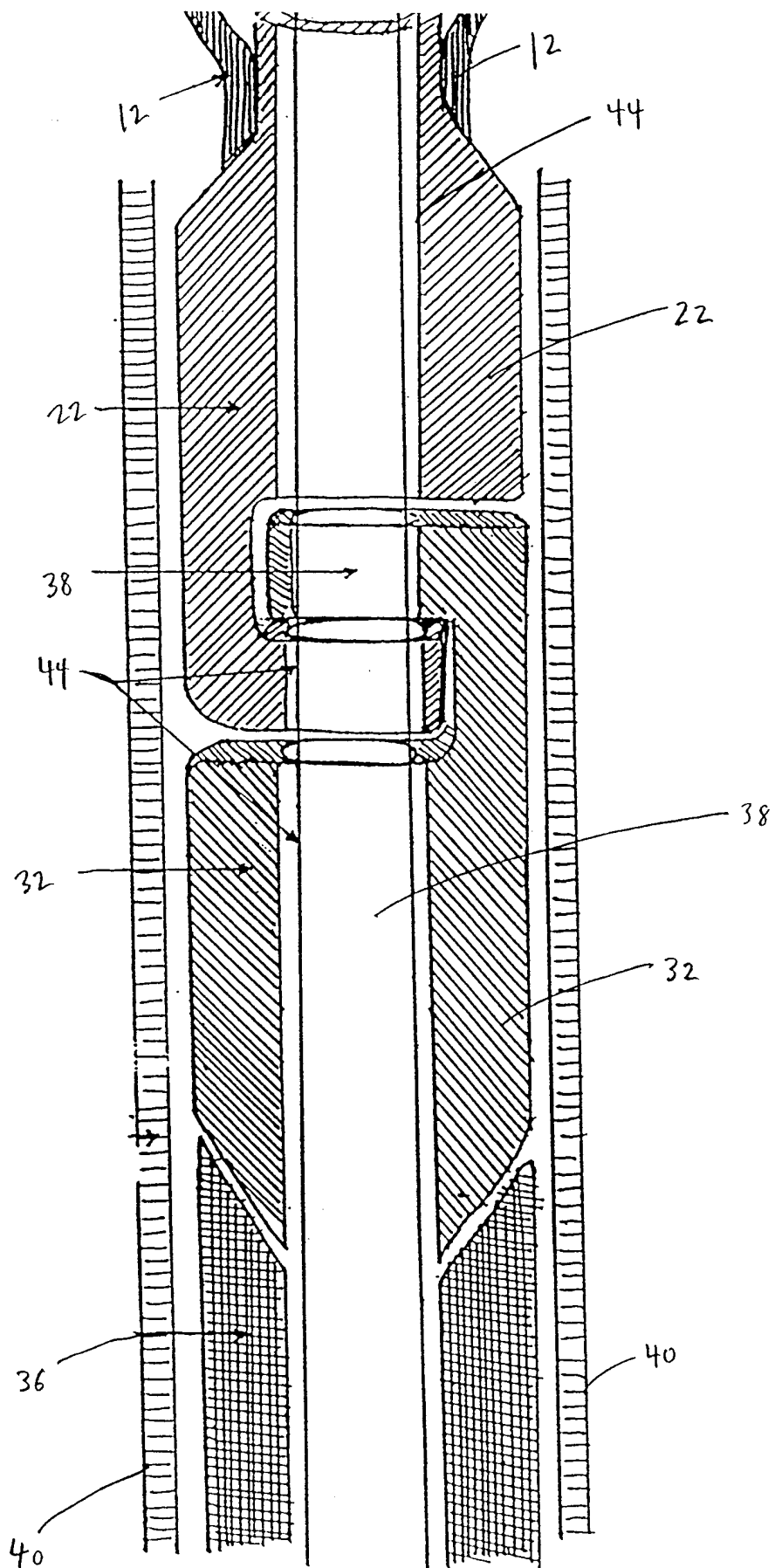

FIG. 15





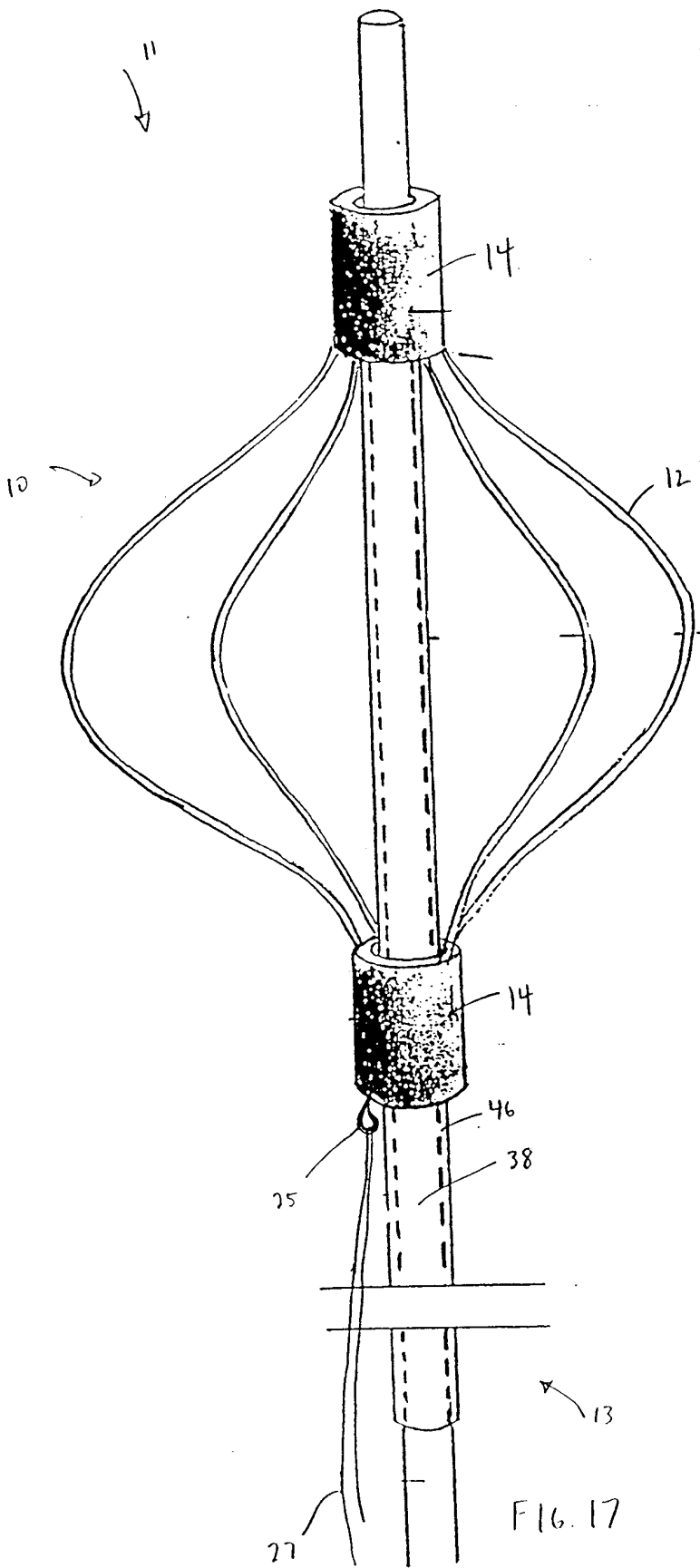

FIG. 17

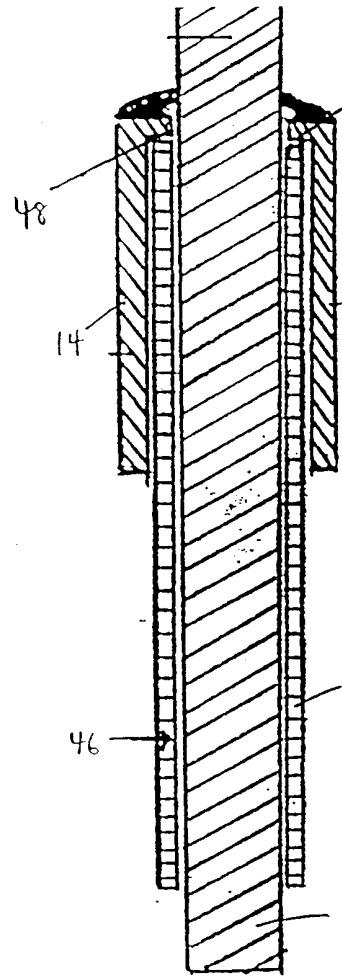

FIG. 18

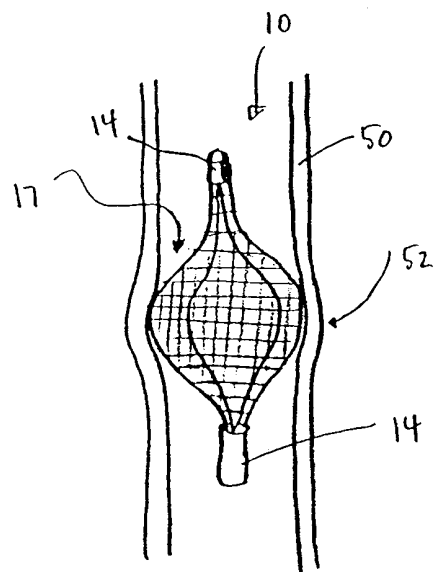

FIG. 19

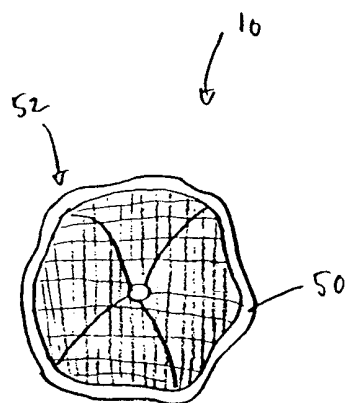

FIG. 20

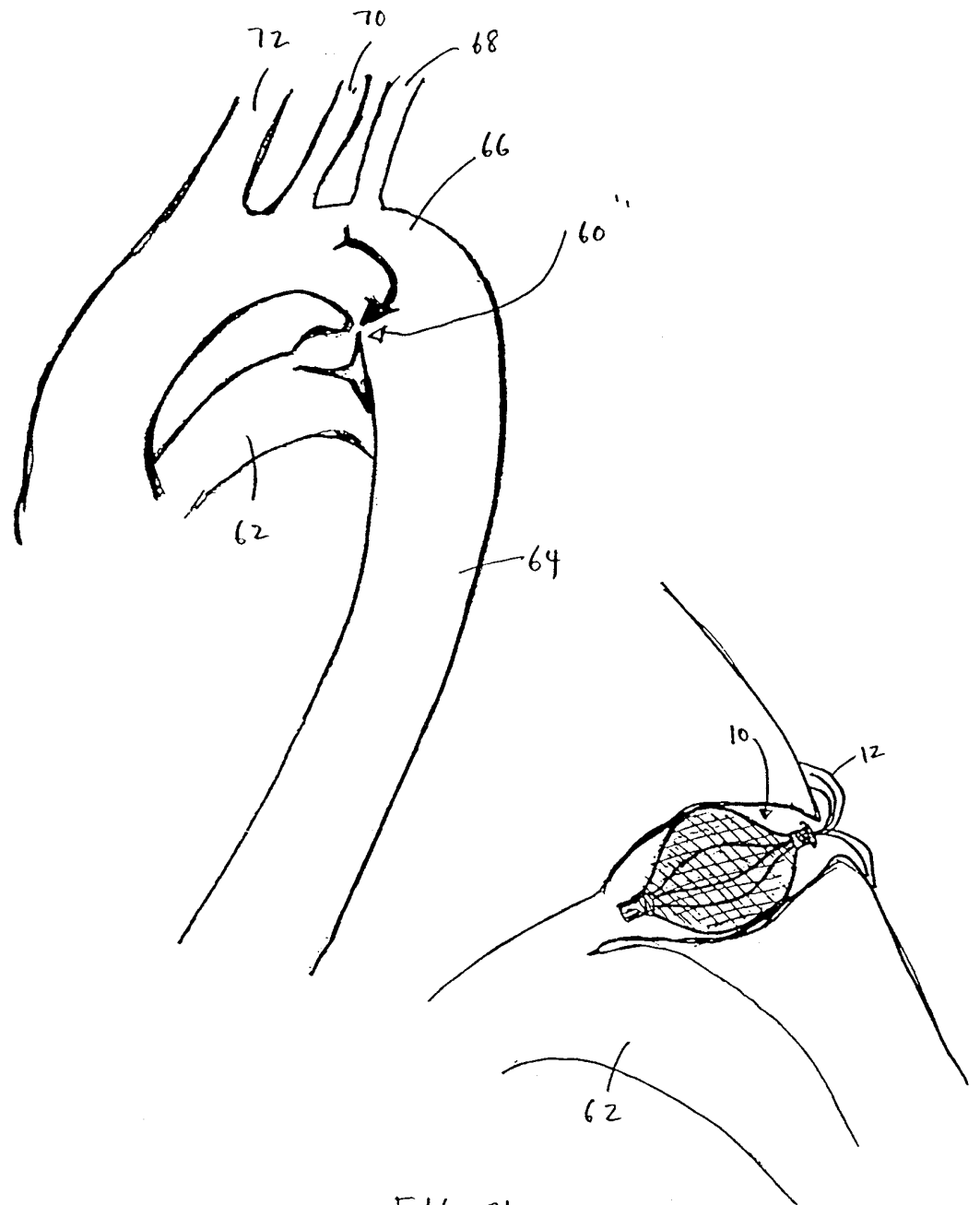

FIG. 21

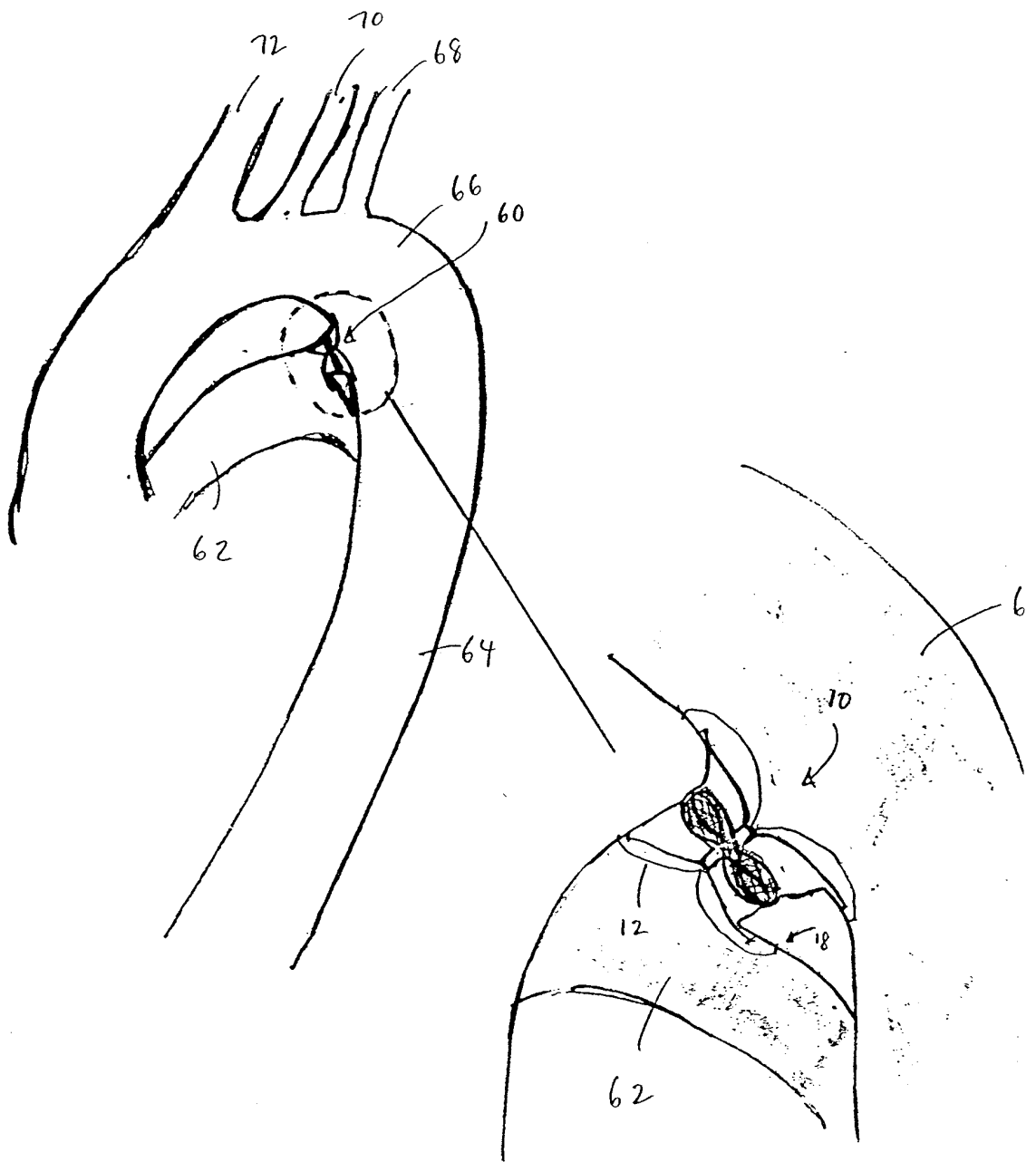

FIG. 22

# INTERNATIONAL SEARCH REPORT

International Application No

PCT/US 00/05682

**A. CLASSIFICATION OF SUBJECT MATTER**

IPC 7 A61B17/12

According to International Patent Classification (IPC) or to both national classification and IPC

**B. FIELDS SEARCHED**

Minimum documentation searched (classification system followed by classification symbols)

IPC 7 A61B

Documentation searched other than minimum documentation to the extent that such documents are included in the fields searched

Electronic data base consulted during the international search (name of data base and, where practical, search terms used)

**C. DOCUMENTS CONSIDERED TO BE RELEVANT**

Category	Citation of document, with indication, where appropriate, of the relevant passages	Relevant to claim No.
X	WO 97 27893 A (TRANSVASCULAR, INC.) 7 August 1997 (1997-08-07)  abstract; figures page 14, line 21 -page 21, line 36	1-11, 14-20, 23,24
Y	--- abstract; figures page 14, line 21 -page 21, line 36	12, 13, 21, 22, 25-28
Y	--- WO 96 18343 A (MICRO INTERVENTIONAL SYSTEMS, INC.) 20 June 1996 (1996-06-20) abstract; figures page 5, line 6 -page 6, line 8 page 9, line 11-38 page 11, line 35 -page 1218 --- -/--	12, 13, 21, 22

Further documents are listed in the continuation of box C.

Patent family members are listed in annex.

Special categories of cited documents:

"A" document defining the general state of the art which is not considered to be of particular relevance

"E" earlier document but published on or after the international filing date

"L" document which may throw doubts on priority claim(s) or which is cited to establish the publication date of another citation or other special reason (as specified)

"O" document referring to an oral disclosure, use, exhibition or other means

"P" document published prior to the international filing date but later than the priority date claimed

"T" later document published after the international filing date or priority date and not in conflict with the application but cited to understand the principle or theory underlying the invention

"X" document of particular relevance; the claimed invention cannot be considered novel or cannot be considered to involve an inventive step when the document is taken alone

"Y" document of particular relevance; the claimed invention cannot be considered to involve an inventive step when the document is combined with one or more other such documents, such combination being obvious to a person skilled in the art.

"&" document member of the same patent family

Date of the actual completion of the international search

15 June 2000

Date of mailing of the international search report

21/06/2000

Name and mailing address of the ISA

European Patent Office, P. B. 5818 Patentlaan 2  
 NL - 2280 HV Rijswijk  
 Tel. (+31-70) 340-2040, Tx. 31 651 epo nl.  
 Fax: (+31-70) 340-3016

Authorized officer

Giménez Burgos, R

# INTERNATIONAL SEARCH REPORT

International Application No  
PCT/US 00/05682

C.(Continuation) DOCUMENTS CONSIDERED TO BE RELEVANT		
Category	Citation of document, with indication, where appropriate, of the relevant passages	Relevant to claim No.
Y	US 5 250 071 A (PALERMO) 5 October 1993 (1993-10-05) abstract; figures ---	25-28
X	DE 92 05 797 U (SCHMITZ-RODE ET AL.) 17 June 1992 (1992-06-17) page 3, line 1-31; claims; figures ---	1,4,6,7, 14
A	DE 197 23 700 A (SHERINE MED. AG) 10 December 1998 (1998-12-10) abstract; figures ---	
P,X	WO 99 12484 A (NEUROVASX, INC.) 18 March 1999 (1999-03-18) the whole document -----	1-24

# INTERNATIONAL SEARCH REPORT

Information on patent family members

International Application No

PCT/US 00/05682

Patent document cited in search report	A	Publication date	Patent family member(s)	Publication date
WO 9727893	A	07-08-1997	US 5830222 A	03-11-1998
			AU 1847197 A	22-08-1997
			AU 1847297 A	22-08-1997
			AU 1847397 A	22-08-1997
			AU 7431696 A	30-04-1997
			CA 2234361 A	17-04-1997
			CA 2244066 A	07-08-1997
			CA 2244079 A	07-08-1997
			CA 2244080 A	07-08-1997
			CN 1218414 A	02-06-1999
			CN 1216929 A	19-05-1999
			CN 1216930 A	19-05-1999
			EP 0954248 A	10-11-1999
			EP 0910298 A	28-04-1999
			EP 0879068 A	25-11-1998
			EP 0932426 A	04-08-1999
			JP 11514269 T	07-12-1999
			WO 9713463 A	17-04-1997
			WO 9727897 A	07-08-1997
			WO 9727898 A	07-08-1997
AU 1275997 A	11-05-1998			
WO 9816161 A	23-04-1998			
<hr/>				
WO 9618343	A	20-06-1996	US 5690671 A	25-11-1997
			EP 0797405 A	01-10-1997
<hr/>				
US 5250071	A	05-10-1993	AT 167068 T	15-06-1998
			AU 669928 B	27-06-1996
			AU 4857793 A	12-04-1994
			AU 684419 B	11-12-1997
			AU 5086996 A	11-07-1996
			CA 2119772 A,C	31-03-1994
			DE 9320840 U	02-03-1995
			DE 69319088 D	16-07-1998
			DE 69319088 T	08-10-1998
			DE 617632 T	30-11-1995
			EP 0617632 A	05-10-1994
			EP 0829236 A	18-03-1998
			ES 2074972 T	01-10-1995
			FI 942276 A	16-05-1994
			JP 2584956 B	26-02-1997
			JP 7502674 T	23-03-1995
			KR 126072 B	19-12-1997
			NO 941363 A	15-04-1994
WO 9406503 A	31-03-1994			
<hr/>				
DE 9205797	U	17-06-1992	NONE	
<hr/>				
DE 19723700	A	10-12-1998	AU 8624798 A	21-12-1998
			WO 9855045 A	10-12-1998
<hr/>				
WO 9912484	A	18-03-1999	AU 9126598 A	29-03-1999
<hr/>				