



- (51) **International Patent Classification:**  
A47B 7/02 (2006.01) A47B 3/08 (2006.01)  
F16B 12/24 (2006.01)
- (21) **International Application Number:**  
PCT/US2013/057348
- (22) **International Filing Date:**  
29 August 2013 (29.08.2013)
- (25) **Filing Language:** English
- (26) **Publication Language:** English
- (30) **Priority Data:**  
61/694,660 29 August 2012 (29.08.2012) US
- (71) **Applicant:** KAM KONNECT, LLC [US/US]; 3010  
Scenic View Court, Seabrook, Texas 77586 (US).
- (72) **Inventor; and**
- (71) **Applicant:** MEADOWS, Benjamin Brian [US/US]; 611  
7th Street, Orange, Texas 77630 (US).
- (74) **Agent:** SCHWALLER, Melissa D.; Ramey & Browning,  
PLLC, 5020 Montrose Blvd., Suite 750, Houston, Texas  
77006 (US).

- (81) **Designated States** (unless otherwise indicated, for every kind of national protection available): AE, AG, AL, AM, AO, AT, AU, AZ, BA, BB, BG, BH, BN, BR, BW, BY, BZ, CA, CH, CL, CN, CO, CR, CU, CZ, DE, DK, DM, DO, DZ, EC, EE, EG, ES, FI, GB, GD, GE, GH, GM, GT, HN, HR, HU, ID, IL, IN, IS, JP, KE, KG, KN, KP, KR, KZ, LA, LC, LK, LR, LS, LT, LU, LY, MA, MD, ME, MG, MK, MN, MW, MX, MY, MZ, NA, NG, NI, NO, NZ, OM, PA, PE, PG, PH, PL, PT, QA, RO, RS, RU, RW, SA, SC, SD, SE, SG, SK, SL, SM, ST, SV, SY, TH, TJ, TM, TN, TR, TT, TZ, UA, UG, US, UZ, VC, VN, ZA, ZM, ZW.
- (84) **Designated States** (unless otherwise indicated, for every kind of regional protection available): ARIPO (BW, GH, GM, KE, LR, LS, MW, MZ, NA, RW, SD, SL, SZ, TZ, UG, ZM, ZW), Eurasian (AM, AZ, BY, KG, KZ, RU, TJ, TM), European (AL, AT, BE, BG, CH, CY, CZ, DE, DK, EE, ES, FI, FR, GB, GR, HR, HU, IE, IS, IT, LT, LU, LV, MC, MK, MT, NL, NO, PL, PT, RO, RS, SE, SI, SK, SM, TR), OAPI (BF, BJ, CF, CG, CI, CM, GA, GN, GQ, GW, KM, ML, MR, NE, SN, TD, TG).

**Published:**

— with international search report (Art. 21(3))

(54) **Title:** REVERSIBLE CONNECTION SYSTEM AND METHOD

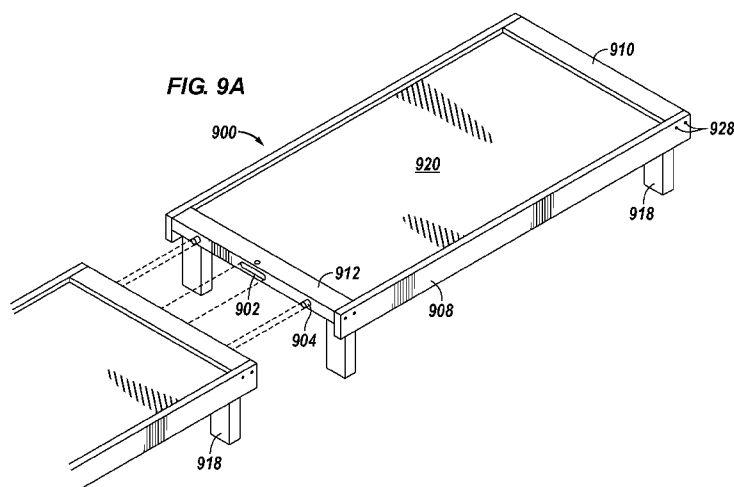

(57) **Abstract:** A reversible connection system for joining two or more surfaces provides a level, dimensionally stable surface. The modules are sturdy and can be connected through a cam locking device and dowels. The legs are capable of being folded for ease of storage and transport.

REVERSIBLE CONNECTION SYSTEM AND METHOD  
RELATED APPLICATIONS

[0001] This application claims priority to U.S. Provisional Application 61/694,660 filed August 29, 2012, herein incorporated by reference.

BACKGROUND

[0002] Reversible joining of various pieces of furniture, *e.g.*, tables, has been accomplished by mechanisms or devices including at least slide locks, clamps, and dowels. A challenge to reversible furniture joining is speed of assembly and precision.

[0003] Dowels have been used in the model train area field for alignment of the modules to each other and maintaining that alignment from assembly to assembly. In these instances, track joiners have been required for a train to run smoothly over the joint between two sections. Generally, there has not been a means of stability tied to the module itself. This allows movement between sections. Modules are usually pulled together with bolts or clamps with very low fit tolerance.

[0004] Model railroad scales include from smallest to largest, Z, N, TT, HOn3, HO, OO, S, On30, O, G. The scale represents the ratio of the model to life-size. Z is 1:220 scale; N is 1:160 scale; TT is 1:120; HOn3 and HO are 1:87.1 scale; OO is 1:76.2; S is 1:64; O and On30 (O scale narrow gauge) are 1:48 scale; and G scale is 1:22.5 to 1:29 scale. Gauge represents the distance between the rails. Track gauge is usually 48 inch 8 1/2 inches. HOn3 is HO scale, narrow gauge, 36 inches between the rails.

[0005] A reversible mechanism for joining furniture that is quick, sturdy, and provides a flush surface is greatly needed. In the model railroad area, a mechanism or system is needed that offers the above and does not require track joiners.

## SUMMARY

[0006] An embodiment of the disclosure discloses a system for the reversible connection of components comprising a male dowel connection present in a surface of a first component; a female dowel connection present in an opposing surface of a second capable of receiving the male dowel connection; a cam locking device present in a surface of the first component; and a cam locking device receiver present in a surface of the second component capable of receiving the cam locking device; wherein the surfaces abut when the cam locking device is received by the cam locking device receiver. In an embodiment, the system can further comprise at least two side rails. In an embodiment, the first component is a male module and the second component is a female module. In another embodiment, the cam locking device is located on an end piece. In a further embodiment, the cam locking device receiver is located on an end piece. In an embodiment, the reversible connection of components is located between two baseboard modules for a model railroad.

[0007] Another embodiment of the disclosure discloses a reversibly connected surface comprising a first table top; a second table top; a male dowel connection present in a surface of the first table top; a female dowel connection present in an opposing surface of the second table top capable of receiving the male dowel connection; a cam locking device present in a surface of the first table top; and a cam locking device receiver present in a surface of the second table top capable of receiving the cam locking device; wherein the surfaces abut when the cam locking device is received by the cam locking device receiver. In an embodiment, the system can further comprise at least two legs connected below the table top. In another embodiment, the legs are capable of being folded towards the bottom of the table top. In an embodiment, the reversibly connected surface can further comprise a road case allowing insertion within the road case of at least one reversibly connected surface. In a further embodiment, the first table top and second table top are comprised of wood. In an embodiment, the first table top and second table top are comprised of Baltic birch plywood. In an embodiment, the reversibly connected surface can further comprise side rails. In an embodiment, the reversibly connected surface comprises at least two side rails. In an embodiment, the cam locking device is located on an end piece. In another embodiment, the end piece is comprised of German beech wood. In an embodiment, the

cam locking device receiver is located on an end piece. In an embodiment, the reversibly connected surface can further comprise comprising an alignment tool possessing a cylindrical hole capable of sliding over the male dowel.

**[0008]** Another embodiment of the disclosure discloses a kit comprising the reversibly connected surface of a reversibly connected surface comprising a first table top; a second table top; a male dowel connection present in a surface of the first table top; a female dowel connection present in an opposing surface of the second table top capable of receiving the male dowel connection; a cam locking device present in a surface of the first table top; and a cam locking device receiver present in a surface of the second table top capable of receiving the cam locking device; wherein the surfaces abut when the cam locking device is received by the cam locking device receiver.

**[0009]** A further embodiment of the disclosure discloses a method of manufacture of reversibly connectable components comprising obtaining at least two dowels; drilling a hole in which to insert a dowel in the surface of a first component; inserting a dowel in the surface of a first component; drilling a hole in the surface of the second component; installing a cam locking device in a milled rabbet of the first component; installing a cam locking device receiver in a milled rabbet of the second component; inserting the dowel protruding from the surface of the first component into the hole in the surface of the second component; and using a tool to cause the cam locking device to be received by the cam locking device receiver.

#### BRIEF DESCRIPTION OF THE DRAWINGS

**[0010]** In order that the manner in which the above-recited and other enhancements and objects of the disclosure are obtained, a more particular description of the disclosure briefly described above will be rendered by reference to specific embodiments thereof which are illustrated in the appended drawings. Understanding that these drawings depict only typical embodiments of the disclosure and are therefore not to be considered limiting of its scope, the disclosure will be described with additional specificity and detail through the use of the accompanying drawings in which:

**[0011]** Figure 1A depicts a top view of a 24 inch wide by 48 inch long rectangular module.

- [0012] Figure 1B depicts a side view of the top of a 48 inch long module.
- [0013] Figure 1C depicts an end view of the top and side rails of a 24 inch wide module.
- [0014] Figure 2 depicts the connection device joining two modules.
- [0015] Figure 3 depicts a perspective view of an octagonal module connected to other modules.
- [0016] Figure 4 depicts a configuration of one octagonal module and four rectangular modules.
- [0017] Figure 5 depicts a configuration of three rectangular modules joined end to end.
- [0018] Figure 6A depicts an alignment tool between two modules.
- [0019] Figure 6B depicts an alignment tool.
- [0020] Figure 7 depicts an alignment tool attached to one module.
- [0021] Figure 8 depicts a road case.
- [0022] Figure 9A depicts the joining of two modules.
- [0023] Figure 9B depicts the dowels in the joining of the two modules.
- [0024] Figure 10 depicts the folding of the legs on the underside of the module.
- [0025] Figure 11 depicts a piece of furniture utilizing dowels and cam locking devices.
- [0026] Figure 12 depicts modules for use in layouts.
- [0027] Figure 13 depicts a layout utilizing various modules.
- [0028] Figure 14 depicts a corner snub module.
- [0029] Figure 15 depicts a 48 inch octagonal split module.
- [0030] Figure 16 depicts sweeping turn modules.

[0031] Figure 17 depicts a 45 degree module.

[0032] Figure 18 depicts layouts using various modules.

[0033] Figure 19A depicts a dress end cap return.

[0034] Figure 19B depicts a dress end cap.

#### DETAILED DESCRIPTION

[0035] The particulars shown herein are by way of example and for purposes of illustrative discussion of the preferred embodiments of the present disclosure only and are presented in the cause of providing what is believed to be the most useful and readily understood description of the principles and conceptual aspects of various embodiments of the disclosure. In this regard, no attempt is made to show structural details of the disclosure in more detail than is necessary for the fundamental understanding of the disclosure, the description taken with the drawings making apparent to those skilled in the art how the several forms of the disclosure can be embodied in practice.

[0036] The following definitions and explanations are meant and intended to be controlling in any future construction unless clearly and unambiguously modified in the following examples or when application of the meaning renders any construction meaningless or essentially meaningless. In cases where the construction of the term would render it meaningless or essentially meaningless, the definition should be taken from Webster's Dictionary 3rd Edition.

[0037] As used herein the term, "abut" means and refers to touching along a border.

[0038] The system can be used for among other uses, hobbyist tables, model railroads, miniature gaming, dioramas, office furniture, conference tables, trade show tables, camping tables, dining room tables, children's play tables, children's beds, cots, and set design for theaters.

[0039] In an embodiment, the tables of the connection system use a concealed cam locking device and large dowel pins. The tables utilizing the connection system are dimensionally stable, *i.e.*, the tables have the ability to maintain their original dimensions throughout use.

[0040] Figure 1A depicts a top view of a 24 inch by 48 inch rectangular module 100. Module 100 comprises side rails 108 and module end pieces (MEPs) 112, 110 around the circumference of the hard bed 114. The male MEP 112 includes a cam locking device 102 present in the male MEP 112. Also present in the male MEP 112 are male dowel connections 104. The female MEP 110 includes a cam locking receiving device 120 and female dowel connections 106. The distance between the dowels on the end pieces is 15 1/4 inches.

[0041] Figure 1B depicts a side view of the top of the module. The hard bed 114 acts as a base for the soft bed 116. In an embodiment, the thickness of the hard bed 114 and soft bed 116 is 3/4 inch. The hard bed 114 is 1/4 inch plywood and the soft bed 116 is 1/2 inch foam. In another embodiment, the thickness of the hard bed 114 and soft bed 116 together is 2 3/8 inches. The cam locking device 102 and cam locking receiving device 120 are present in the male MEP 112 and female MEP 110 respectively. In an embodiment, there are 21 inches between the side rails 108. In an embodiment, the inside width is 22 1/2 inches. In an embodiment, the male dowel connections 104 are located 16 5/16 from center to center. In another embodiment, the male dowel connections 104 are located 15 1/4 inches from each other.

[0042] Figure 1C depicts an end view of the module. Side rails 108 are present on each side of a female module end piece 110. A cam locking receiving device 120 is centered vertically and horizontally in the female module end piece 110. Female dowel connections 106 are present in the female module end piece 110. In an embodiment, the female module end piece 110 is 21 inches in length.

[0043] Figure 2 depicts a first module 200 and a second module 230. Side rails 208 are connected to the male MEP 212 and female MEP 210. A cam lock hole 206 is present in the male MEP 212 for the purpose of engaging the cam locking device. Male dowel connections 204 are also present in the male MEP 212. Fasteners can pass through the side rail 208 into the male MEP 212 and female MEP 210. Legs can be connected to the underside of the module. An

initial module can have 4 legs whereas additional modules only require 2 legs. In an embodiment, a fastener can be a screw, nail, bolt, or other suitable attachment mechanism.

**[0044]** Figure 3 depicts a module layout 300 comprising an octagonal module 328 connected to two 24 inch by 48 inch modules 326. In an embodiment, a hole 324 is present in the wood corresponding to the cam locking device 302. In an embodiment, a 5 1/6 inch hex tool 322 is used to open and close the cam locking device 302. The cam locking device 302 draws the tables tightly together to create an almost seamless fit. In an embodiment, each module is independently wired allowing the track to abut without rail joiners. The 24 inch by 48 inch modules 326 comprise a hard bed 320. Side rails 308 are attached to the male MEPs 312 and female MEPs 310. A female dowel connection 306 is present in the female MEP 310.

**[0045]** Figure 4 depicts the 24 inch by 48 inch rectangular module 416 joined to an octagonal module 428. In various embodiments, the octagonal modules can be 36 inches, 48 inches or any other suitable diameter. A standard 36 inches octagonal module 428 comes with plywood base filler as a hard bed in the middle. The 24 inch by 48 inch rectangular module 416 can be attached to the octagonal module 428. The octagonal module 428 and rectangular modules 416 can have legs attached to the underside of the module. Side rails 408 are present around the hard bed 420 and the female MEP 410. A cam locking device is present on multiple sides of the octagonal module 428. A cam locking hole 424 is used to engage the cam locking device. A female dowel connection 406 is present in the female MEP 410. A male MEP 412 is present on the opposite end of the 24 inch by 48 inch rectangular module from the female MEP 410. In an embodiment, three octagonal modules can be added to the layout 400. In various embodiments, a standard circuit pattern, single H patterns, or multiple H patterns can be created. In an embodiment, the 48 inch octagonal module can be used as an end unit for up to an 18 inch radius turnaround. In an embodiment, the 48 inch octagonal module allows attachment on four sides without fill modules. In an embodiment, the module can join with other modules on all sides. In an embodiment, a module can separate into two equal portions for ease of transport. Octagonal modules that are 48 inches can be capable of separating into 2 pieces and be sold in 2 piece units.

[0046] Figure 5 depicts a rectangular module layout 500. Side rails 508, a male MEP 512, and a female MEP 510 form the circumference of the hard bed 520. Male dowel connections 504 and a cam locking device hole 502 are present on the male MEP 512. Female dowel connections 506 are present on the female MEP 510. In an embodiment, the hard bed 520 is made of plywood. A soft bed fits into the indentation formed by the side rails 508, male MEP 512, female MEP 510, and a hard bed 520. In an embodiment, the soft bed is blue foam. Legs can be attached to the underside of the rectangular modules and provide support for the modules. Indentations can be present in the side rail 508.

[0047] Figure 6A depicts an alignment tool 626 between two modules 600. In an embodiment, an alignment tool 626 can be used to ensure that track is laid in a straight line across modules 600. After securing track to the module 600, the track can be cut with a rotary tool or other cutting tool. In an embodiment, a different alignment tool can be utilized for each model railroad scale. A side rail 608 is attached to the male MEP 612 by fasteners. A side rail is attached to the female MEP 610 by fasteners. A soft bed 622 is present between the side rails 608 and male MEP 612 and female MEP 610. A male dowel connection 632 and a cam locking device hole 602 are present on the male MEP 612.

[0048] Figure 6B depicts an alignment tool 626. The alignment tool 626 fits in between two modules and slides over the male dowel connection 632. The track is aligned by the track guides 634.

[0049] Figure 7 depicts an alignment tool 726 attached to a module. The alignment tool 726 slides onto the male dowel connection 732. The alignment tool 726 is adjacent to the male MEP 712. Track guides 734 indicate where the track should be placed. The module can be supported by legs. A fastener connects the side rail 708 to the male MEP 712. A hard bed 714 is present between the male MEP 712 and the side rail 708. A female MEP is present on the opposite end of the module from the male MEP 712. A male dowel connection 732 and cam locking device 702 are present on the male MEP 712. In an embodiment, the male dowel connections 732 can be located on the female MEP. In an embodiment, the cam locking device 702 can be located on the female MEP. In an embodiment, an alignment tool 726 provides a guide for laying model

railroad track on the modules in compliance with National Model Railroad Association standards (NMRA). The track laying standards measure placement of the tracks from the edge of the module. In an embodiment in which the tables are used for a model railroad, rail joiners are not necessary for the train to travel smoothly on the tracks of the seams between the modules.

**[0050]** Figure 8 depicts a road case 800. In an embodiment, the components are designed to fit in a road case 800. In an embodiment, the road case 800 has wheels. In an embodiment, the road case 800 is capable of holding up to four modules on shelves 830. In another embodiment, the road case 800 is capable of holding up to six modules. In an embodiment, the road case 800 can be placed under a four-legged module for extra stability and to reduce the amount of gear surrounding the layout. In an embodiment, gear can be stored in the road case 800 after the modules are removed. The road case comprises a case 832, cam locking device holes 836, and a door 834.

**[0051]** Figure 9A depicts two rectangular modules 900 to be joined. Side rails 908 are attached to the male MEP 912 and female MEP 910 by fasteners 928 and surround a hard bed 920. The module is supported by legs 918. The male MEP 912 comprises two male dowel connection mechanisms 904 and a cam locking device 902. The cam locking receiving device 906 provides a way to engage the cam locking device 902.

**[0052]** Figure 9B depicts the joining of two rectangular modules 900 by inserting a male dowel connection 904 into a female dowel connection 906. Side rails 908 are attached to a male MEP 912 and a female MEP 910 using fasteners 928. A hard bed 914 is present between the side rails 908, male MEP 912, and female MEP 910.

**[0053]** Figure 10 depicts that the legs 1018 of the modular table 1000 lock in the up or down position. The legs 1018 are attached to the underside 1034 of the module 1000. The legs 1018 can be in an extended position (down) 1036 or folded into the leg storage position (up) 1038 using leg folding mechanism 1032. In an embodiment, the leg folding mechanism 1032 is a hinge. When the legs 1018 are locked in the storage (up) position 1038, the modules 1000 can be slid into a road case for easy travel and storage. Side rails 1008 attach substantially perpendicularly to the underside 1034 of the module 1000.

[0054] Figure 11 depicts a piece of furniture 1100 that is reversibly assembled using the reversible connection components 1140 comprising dowel connections and cam locking devices. Locations of the dowels and cam locking devices provide for quick assembly and disassembly.

[0055] Figure 12 depicts various modules 1200 in addition to 24 inch x 48 inch modules that can be used in a layout in an embodiment of this disclosure. Various modules include but are not limited to a 36 inch octagonal 1250, 48 inch octagonal 1252, 48 inch octagonal split 1254, corner snub 1256, corner right angle 1258, 24 inch x 24 inch square 1260, corner snub with reversed connections 1262, and 24 inch sweep corner 1264.

[0056] Figure 13 depicts a layout 1300 utilizing various modules. Layout 1300 includes 24 inch x 48 inch rectangular modules 100, 36 inch octagonal modules 1250, corner snub 1256, corner snub with reversed connections 1262, 48 inch octagonal split 1254, curved corner 1266, arc 1270, and a custom length module 1268.

[0057] Figure 14 depicts a layout 1400 including a 36 inch octagonal module 1450, two 24 inch by 48 inch rectangular modules 1414, and a corner snub module 1462. The corner snub module 1462 can be used to connect modules to break out at 45 degree angles or expand a corner radius.

[0058] Figure 15 depicts a 48 inch octagonal split module 1500. The module 1500 comprises an octagon that is split into equal portions and joined by a cam locking device and dowels. Cam locking device holes 1506 are present to engage the cam locking devices. A male MEP 1512 is present around the circumference and through the middle of the octagon.

[0059] Figure 16 depicts a layout 1600 of sweeping turn modules including but not limited to a 72 inch sweeping turn 1650, 36 inch sweeping turn 1660, and segments 1670. A 24 inch sweeping corner 1664 can also be used in the layout. The sweeping turn modules are part of an architectural series that allows the system to meander through a lobby or home with sweeping turns. The sweeping turns can be made in any radius.

[0060] Figure 17 depicts a 45 degree module 1765. The 45 degree module is available for including but not limited to 24 inch modules. Each 45 degree module is bordered with a male MEP 1712 and female MEP 1710.

[0061] Figure 18 depicts layouts using various modules. A first layout 1872 utilizes cones. A second layout 1874 utilizes sweeping turn modules, rectangular modules, and custom size modules. A third layout 1876 utilizes a corner right angle, rectangular module, and an octagonal module. A fourth layout 1878 utilizes a includes 24 inch x 48 inch rectangular modules, 36 inch octagonal modules, corner snub, corner snub with reversed connections, and a 48 inch octagonal split. The modules are connected with dowel connections and cam locking devices.

[0062] Figure 19A depicts a dress end cap return 1900 for a 48 inch module. The dress end cap return 1900 can be placed over the end of a module. The dress end cap return 1900 is attached using male dowel connections 1904, female dowel connections 1906, cam locking devices 1902, and cam locking receiving devices 1920. A cam locking device hole 1960 is present to activate the cam locking device 1920.

[0063] Figure 19B depicts a dress end cap 1980 for a 24 inch module. The dress end cap 1980 can be placed over the end of a module. The dress end cap return is attached using male dowel connections 1904, female dowel connections 1906, cam locking devices 1902, and cam locking receiving devices 1920.

[0064] In an embodiment, the dimensions of the top of the modules can range from 12 inches to 59 inches. In an embodiment, modules are 24 inch by 24 inch. In an embodiment, modules are 24 inch by 48 inch. In another embodiment, the modules are 48 inch by 48 inch. In an embodiment, the top of the modules is 24, 36, or 48 inches in length and 12, 18, 24, or 30 inches in width. In an embodiment, different sizes and shapes of modules can be connected.

[0065] In an embodiment, the hard bed 114 of the modules can be made out of plywood. In an embodiment, the wood forming the bottom panel of the module is Baltic birch plywood. In an embodiment, the side rails can be made out of German beech. In an embodiment, the wood is

not susceptible to warping. In an embodiment, the road case 800 is made out of hard ash. In an embodiment, any wood that is not susceptible to warping can be used to construct the module.

[0066] In an embodiment, the material in the soft bed 522 or top center of the modules is blue foam. In an embodiment, the blue foam material fits in the top in a depressed area on the top of the module. The foam allows the tables to be lighter. In an embodiment, the top of the table can be wood. The blue foam provides a suitable surface upon which to model. In various embodiments, a material selected from the group consisting of foam board, depron foam, blue foam (extruded polystyrene), pink foam (extruded polystyrene), and Styrofoam was used for the soft bed 522.

[0067] In an embodiment, the shape of the modules can be rectangular, square, octagonal, or other polygon. Modules of varying shapes and sizes can be joined together using the connection system of dowels, rabbets, and rotary locks. In an embodiment, a module can be capable of separating to provide ease of transport.

[0068] In an embodiment, the dowels are capable of being inserted into a 5/8 inch hole. In an embodiment, the slot for the cam locking device is milled into the module end piece.

[0069] In an embodiment, the length of the legs can be 6 inches to 36 inches. In another embodiment, the length of the legs is 34 1/2 inches.

[0070] In an embodiment, covers can be placed in front of the rotary lock housing for aesthetic reasons. In an embodiment, a rabbet may be cut into the wood and a removable cover placed in the rabbet until such time as a rotary lock is to be installed. In an embodiment, rabbets can be cut into the side rails and module end pieces to be assembled into a module. In another embodiment, rabbets are not cut into the side rails.

[0071] In an embodiment, the modules may include a pegged base board for toy building bricks on top of the hard bed. Toy building brick structures can be built on top of the pegged base board. The portability and reversibly connectable modules provide for a toy building brick table that can be assembled in various layouts and easily moved from location to location. The legs of the modules can vary in height depending upon the application. The legs can be folded

under the module and placed in a road case. In an embodiment, a road case can hold four to six tables. In an embodiment, another road case can hold the toy building bricks. In an embodiment, the toy building bricks can be stored in a sieve-type container to enable disinfecting of the toy building blocks between uses. In an embodiment, the modules with the pegged base boards, toy building bricks, road cases, and sieve containers can be sold as a kit.

[0072] In an embodiment, the modules can slide into a wheeled road case for travel or storage. The legs on the underside of the module lock in the extended or folded position. The module can be slid into the road case when the legs are in the folded position. In the extended position, the legs lock in place to provide a table surface. In an embodiment, the first module set up requires four legs. In an embodiment, further tables having only two legs can be set up in conjunction with the first module.

[0073] In an embodiment, the modules and road case can be finished as furniture. In an embodiment, the modules and road cases can be mass produced or custom made.

[0074] In an embodiment, the modules can be used for conference tables. In an embodiment, a hard surface would be present in place of the soft bed. In an embodiment, the joining of additional 2 legged modules to a 4 legged module directly or indirectly to the 4 legged module eliminates the problem of two sets of legs next to each other.

[0075] In an embodiment, pre-existing conference tables can be modified to comprise a dowel and cam connection. In an embodiment, the existing table is a conference table. In another embodiment, conference tables can be made with dowel and cam connections.

[0076] In an embodiment, skirting may be placed around the base of the modules. In an embodiment, the skirting can be a wood laminate. In an embodiment, the laminate can be up to 48 inches. In an embodiment, four portions of laminate can be used in forming a circle track.

[0077] The system is capable of sustaining considerable weight. In an embodiment, a 24 inch by 48 inch module can hold at least 50 pounds distributed. In another embodiment, a 24 inch by 48 inch module can hold at least 100 pounds distributed.

[0078] In an embodiment, the system is customizable. In an embodiment, a polygonal module connects a 24 inch by 48 inch module with one of the four sides of the octagon that are shorter in length than the other four sides. In an embodiment, all eight sides of the octagon are the same length.

[0079] In an embodiment, modules could be used by modelers of all kinds and architects. In an embodiment, the modules provide a space for the construction of models of buildings. The architect could work on the buildings on each module separately or together, separate the modules for travel, and connect the modules together when needed for a presentation.

[0080] In an embodiment, the modules can be used as toddler beds or cots for camping. Multiple rectangular modules can be connected together to form a bed. Legs can be of the appropriate height for a bed. The ability to disconnect the portions of the cot allows for easy transport in a vehicle or storage in a closet.

[0081] In an embodiment, the modules can be used for trade show booths as part of a portable, easily assembled display. The road cases can be stored underneath the modules allowing for maximum free space in the trade show booth. The modules can be individually wired and merely need to be connected to a power source to provide an energy source for need equipment.

[0082] In an embodiment, office furniture can be made or modified to comprise a dowel and cam connection. The mechanism of releasable connection allows for versatility of office furniture configuration.

[0083] In an embodiment, the dowel and cam connection can be used for a reversible connection for theater sets. The connection holds the set firmly together and the sets can be separated and stored when they are no longer needed.

[0084] The optional lip on the sides of the table top allows for insertion of a foam inset. The foam inset can be used as a platform for placing terrain, track, and scenery. The modules are suitable for use model railroads, miniature gaming, dioramas, and any use for which a sturdy, reversibly connected base is needed. The modules are also suitable for scale models of towns or landmarks.

[0085] The modules provide tables that are strong and dimensionally stable. In an embodiment, the joined tables are level.

#### Example

[0086] Examples and methods of use are described herein as a basis for teaching one skilled in the art to employ the disclosure in any appropriate manner. These examples disclosed herein are not to be interpreted as limiting.

[0087] An embodiment of the disclosure is a system that allows for the precise alignment of various application modules for the construction of model railroad layouts. Lateral or vertical movement between the modules damages or destroys the track sections between the modules. The use of alignment dowels combined with a cam locking device integral to the module prevents movement between modules tremendously reduces or eliminates damage from lateral or vertical movement.

[0088] The mating pieces are precisely milled and aligned by dowel pins drawn together by means of a cam locking device. The system allows for the easy disassembly and reassembly of modular model railroad layouts without the usual need of joiner rails between modules.

[0089] In an embodiment, the disclosure includes but is not limited to a cam locking device 102; male dowel connections 104; male module end piece ("male MEP") 108; female module end piece ("Female MEP") 110; side rails 108; hard bed 114; and a soft bed 116. Figure 1A-1C.

[0090] Each standard run module piece consists of two side rails 108 held together with a male and female module end piece 112, 110. The male MEP 112 and female MEP 110 are made to join with a high degree of precision. The male dowel connections 104 are used for alignment and a cam locking device 102, 120 is used for joining pressure. The modeling bed (the area between the previously mentioned parts) 118 is attached via gluing and fitting in mortised and rabbeted areas of the male MEP 112, female MEP 110, and side rails 108.

[0091] The standard run module can be used alone for "Z Scale" coffee table modeling or can be joined together for whatever size layout you desire in any scale. If the layout is set up to

NMRA (National Model Railroad Association) standards, it is possible for the modules to be assembled in different configurations. The high tolerance fit of the modules allow the topside to be flush with each other regardless of the order they are assembled and fastened together with an integral cam lock to secure them.

**[0092]** The Module End Pieces (MEPs) 112, 110 are milled to a 1 3/8 inches height x 3 inches width x 22 1/2 inches length stock. A slot for the male cam locking device 102 is milled into the 1 3/8 inches edge as well as a 5/8 inch hole 106 for the male dowel connections 104. In an embodiment, the spacing of the male dowel connections 104 is from the center. In an embodiment, the dowel connections will be 8 inches apart center to center on a 12 inch wide module. The holes 106 are centered in the edge of the stock.

**[0093]** The female Module End Piece (MEP) 110 is made from the same dimensioned stock and a slot is milled for the female cam lock piece 120 and 5/8 inch holes 106 are bored to accept the dowels from the male pieces at 3 inches from the edges. The side rails 108 are laminated material that is 2 3/8 height, 3/4 width and 47 3/4 inches long. The side rails 108 are then attached to the male MEP 112 and female MEP 110.

**[0094]** The modular system allows for the rapid setup and teardown of portable model railroads. By the use of integral alignment dowels including male dowel connections 104 and female dowel connections 106 and cam locking devices 102, 120, the need to carry loose fastening pieces is eliminated. With integrated legs 210, the layout can be set up by one person and eliminates the need to carry leg sections. In an embodiment, the reversibly connectable system may be used for a model railroad holiday display in a lobby, restaurant, department store, or home.

**[0095]** In an embodiment, a locking hinge system 1032 is used to folding legs in a tight pattern. In an embodiment, the leg length is 34 1/2 inches resulting in a standard module height of 36 inches. In an embodiment, the legs 1010 are made from beech wood, a durable hard wood that resist warping.

[0096] The male MEP 112 and female MEP 110 are rabbeted or mortised depending on the design and the side rails 108 are mortised to accept the hard bed material 114. These parts are assembled in an assembly jig to maintain specs and tolerances. The soft or modeling bed can be made of different materials.

[0097] The male MEP 112, female MEP 110, and side rails 108 are milled to a high dimension tolerance enabling the modules to conform to standards. The integral leg assembly is optional as the units may be placed flat on the floor or sawhorses or other support devices.

[0098] The use of alignment dowels including male dowel connections 104 and female dowel connections 106 combined with a cam locking device 102, 120 integral to the module prevents movement between modules therefore tremendously reducing or eliminating damage from lateral or vertical movement. The modules are lined up with their proper mating ends and the locking wrench is inserted into the cam locking device hole. The pieces are pushed together by hand as much as possible and the cam lock is turned to close the distance between the modules.

[0099] Other modules in the design include a breakout module allowing modules to be attached perpendicularly. An end module allows the attachment of modules running side by side. Left and Right hand modules allow left and right hand turns. End caps allow joining of parallel runs. Angle modules allow for 22.5 and 45 degree deviations. Custom modules allow a combination of configurations using the same module.

[0100] A number of embodiments have been described. Nevertheless it will be understood that various modifications can be made without departing from the spirit and scope of the disclosure. Accordingly, other embodiments are included as part of the disclosure and can be encompassed by the attached claims. Furthermore, the foregoing description of various embodiments does not necessarily imply exclusion. For example, "some" embodiments, "exemplary" embodiments, or "other" embodiments can include all or part of "some," "other," and "further" embodiments within the scope of this disclosure.

[0101] All of the compositions and methods disclosed and claimed herein can be made and executed without undue experimentation in light of the present disclosure. While the

compositions and methods of this disclosure have been described in terms of preferred embodiments, it will be apparent to those of skill in the art that variations can be applied to the compositions and methods and in the steps or in the sequence of steps of the methods described herein without departing from the concept, spirit and scope of the disclosure. More specifically, it will be apparent that certain agents which are both chemically and physiologically related can be substituted for the agents described herein while the same or similar results would be achieved. All such similar substitutes and modifications apparent to those skilled in the art are deemed to be within the spirit, scope and concept of the disclosure as defined by the appended claims.

## CLAIMS

What is claimed is:

1. A system for the reversible connection of components comprising  
a male dowel connection present in a surface of a first component;  
a female dowel connection present in an opposing surface of a second capable of  
receiving the male dowel connection;  
a cam locking device present in a surface of the first component; and  
a cam locking device receiver present in a surface of the second component capable of  
receiving the cam locking device;  
wherein the surfaces abut when the cam locking device is received by the cam locking  
device receiver.
2. The system of claim 1 further comprising at least two side rails.
3. The system of claim 1 wherein the first component is a male module and the second  
component is a female module.
4. The system of claim 1 wherein the cam locking device is located on an end piece.
5. The system of claim 1 wherein the cam locking device receiver is located on an end  
piece.
6. The system of claim 1 wherein the reversible connection of components is located  
between two baseboard modules for a model railroad.
7. A reversibly connected surface comprising  
a first table top;  
a second table top;  
a male dowel connection present in a surface of the first table top;  
a female dowel connection present in an opposing surface of the second table top capable  
of receiving the male dowel connection;  
a cam locking device present in a surface of the first table top; and  
a cam locking device receiver present in a surface of the second table top capable of  
receiving the cam locking device;

- wherein the surfaces abut when the cam locking device is received by the cam locking device receiver.
8. The reversibly connected surface of claim 7 further comprising at least two legs connected below the table top.
  9. The reversibly connected surface of claim 8 wherein the legs are capable of being folded towards the bottom of the table top.
  10. The reversibly connected surface of claim 7 further comprising a road case allowing insertion within the road case of at least one reversibly connected surface.
  11. The reversibly connected surface of claim 7 wherein the first table top and second table top are comprised of wood.
  12. The reversibly connected surface of claim 11, where the first table top and second table top are comprised of Baltic birch plywood.
  13. The reversibly connected surface of claim 7 further comprising side rails.
  14. The reversibly connected surface of claim 13 further comprising at least two side rails.
  15. The reversibly connected surface of claim 7 wherein the cam locking device is located on an end piece.
  16. The reversibly connected surface of claim 15 wherein the end piece is comprised of German beech wood.
  17. The reversibly connected surface of claim 7 wherein the cam locking device receiver is located on an end piece.
  18. The reversibly connected surfaces of claim 7 further comprising an alignment tool possessing a cylindrical hole capable of sliding over the male dowel.
  19. A kit comprising the reversibly connected surface of claim 7.
  20. A method of manufacture of reversibly connectable components comprising obtaining at least two dowels;  
drilling a hole in which to insert a dowel in the surface of a first component;  
inserting a dowel in the surface of a first component;  
drilling a hole in the surface of the second component;  
installing a cam locking device in a milled rabbet of the first component;  
installing a cam locking device receiver in a milled rabbet of the second component;

inserting the dowel protruding from the surface of the first component into the hole in the surface of the second component; and  
using a tool to cause the cam locking device to be received by the cam locking device receiver.

**FIG. 1A**

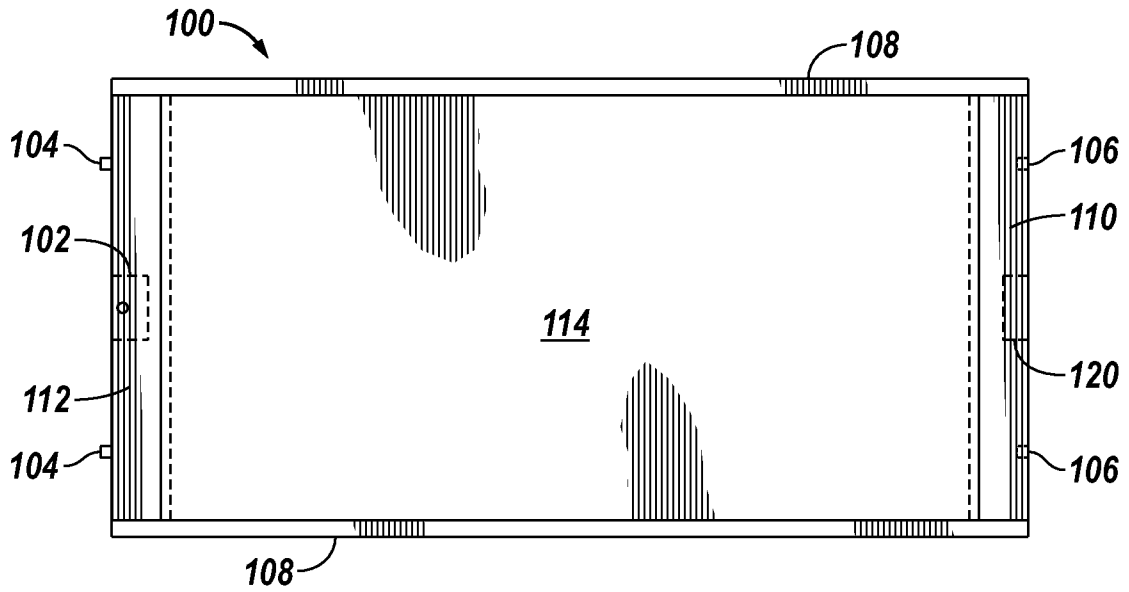

**FIG. 1B**

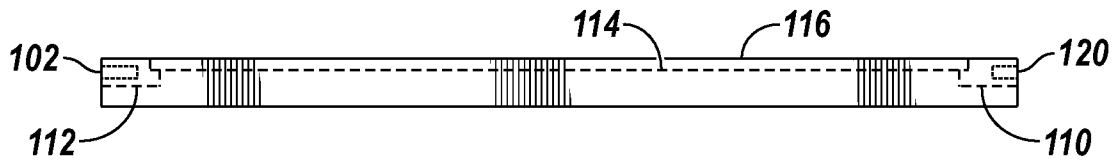

**FIG. 1C**

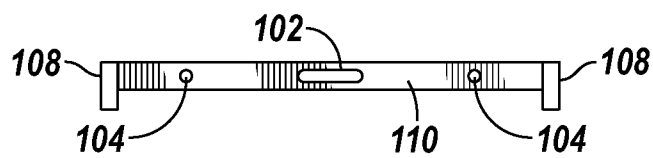

**FIG. 2**

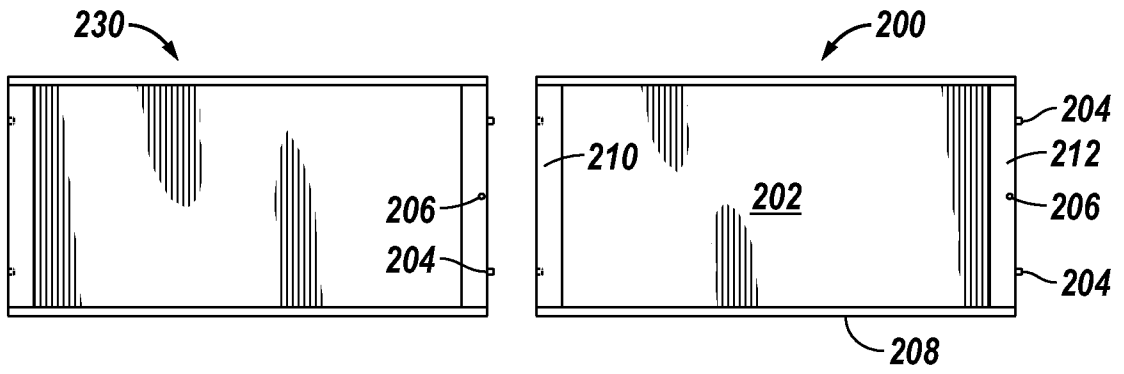

**FIG. 3**

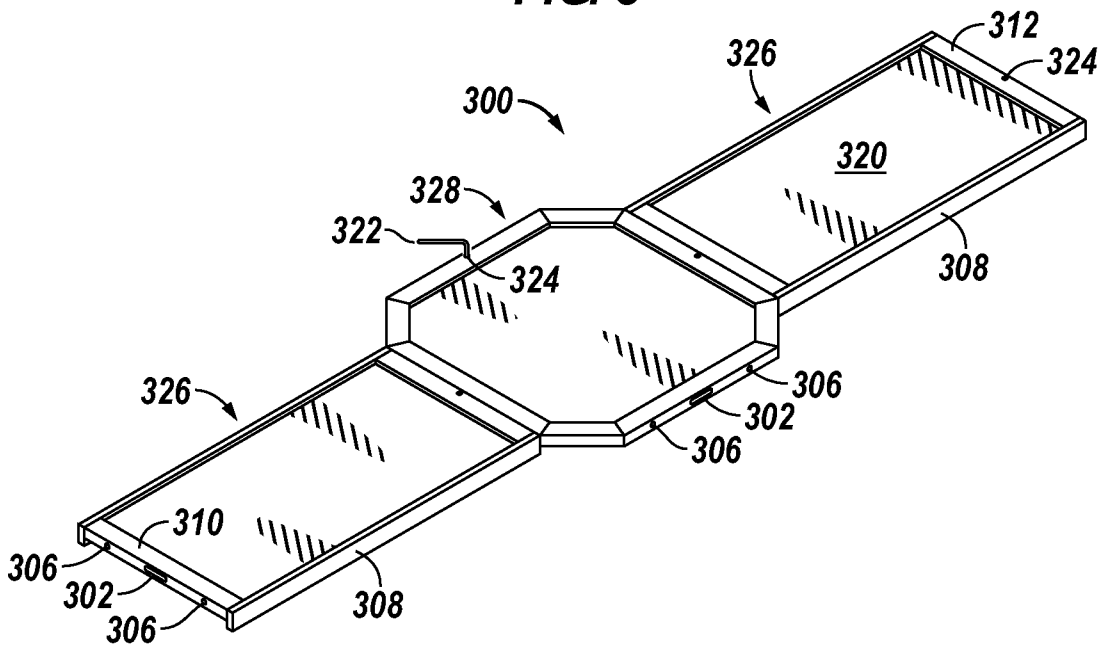

**FIG. 4**

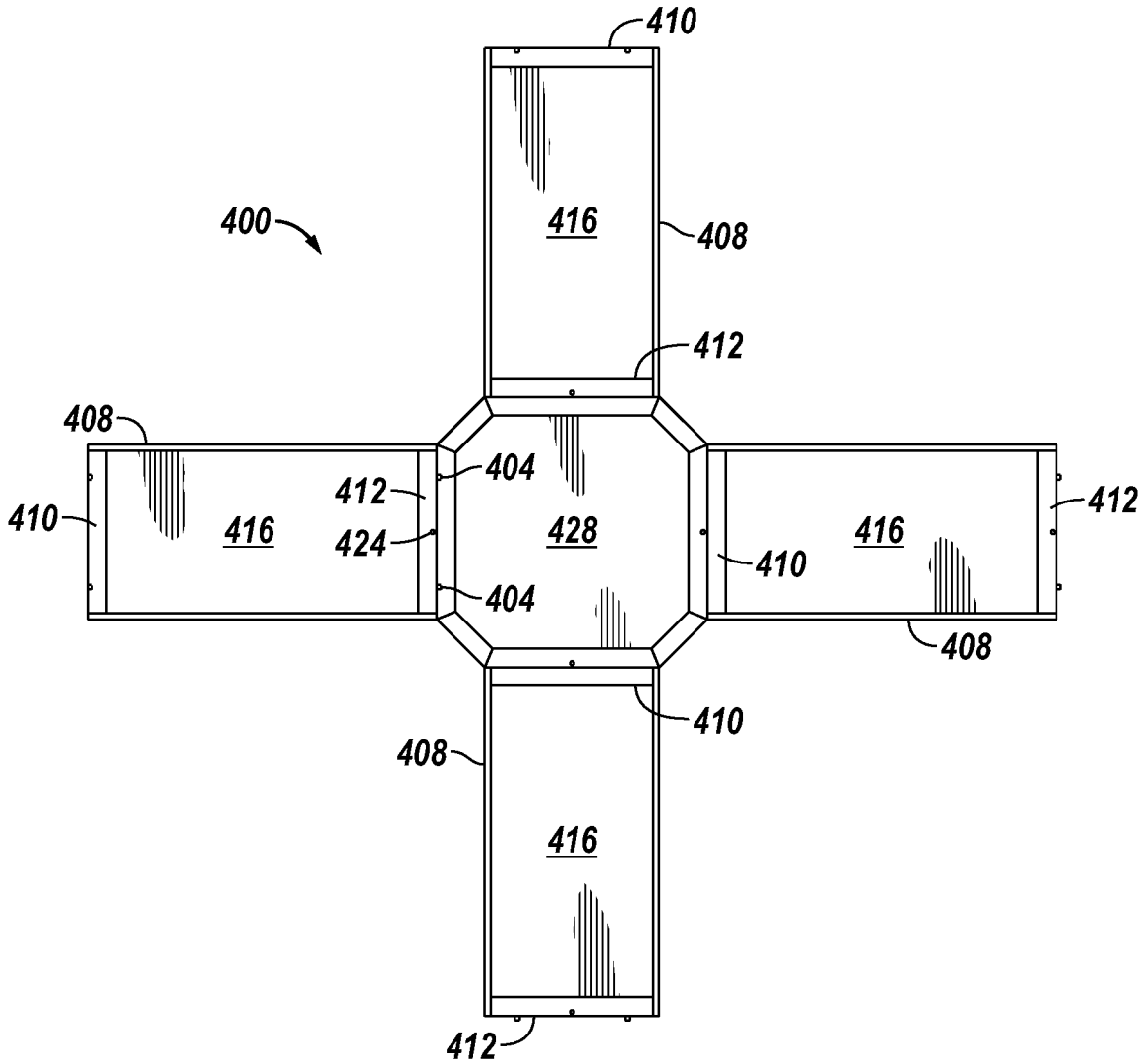

**FIG. 5**

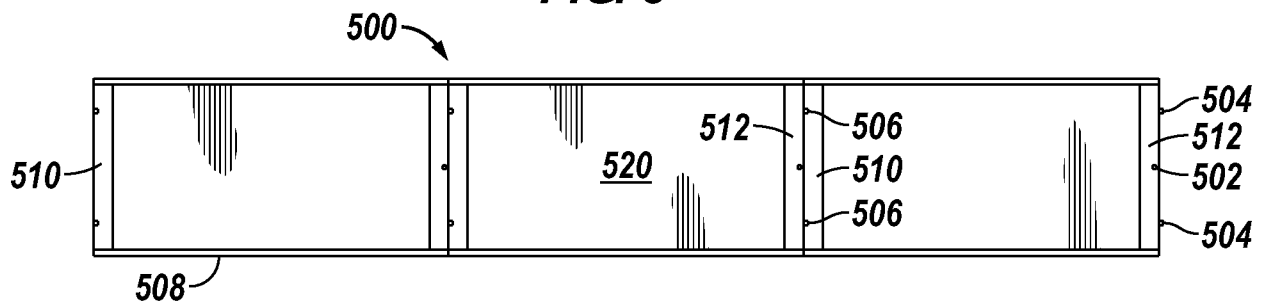

**FIG. 6A**

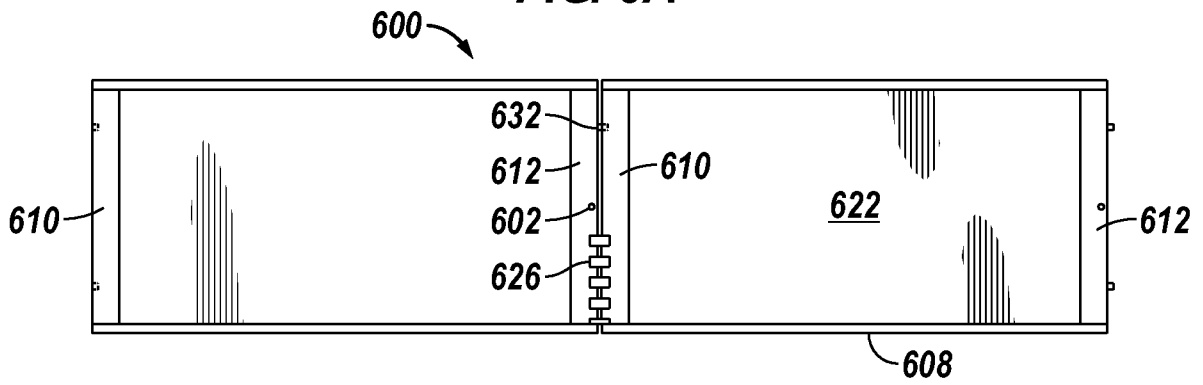

**FIG. 6B**

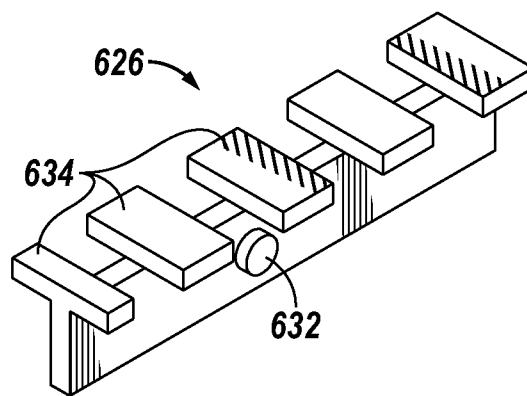

**FIG. 7**

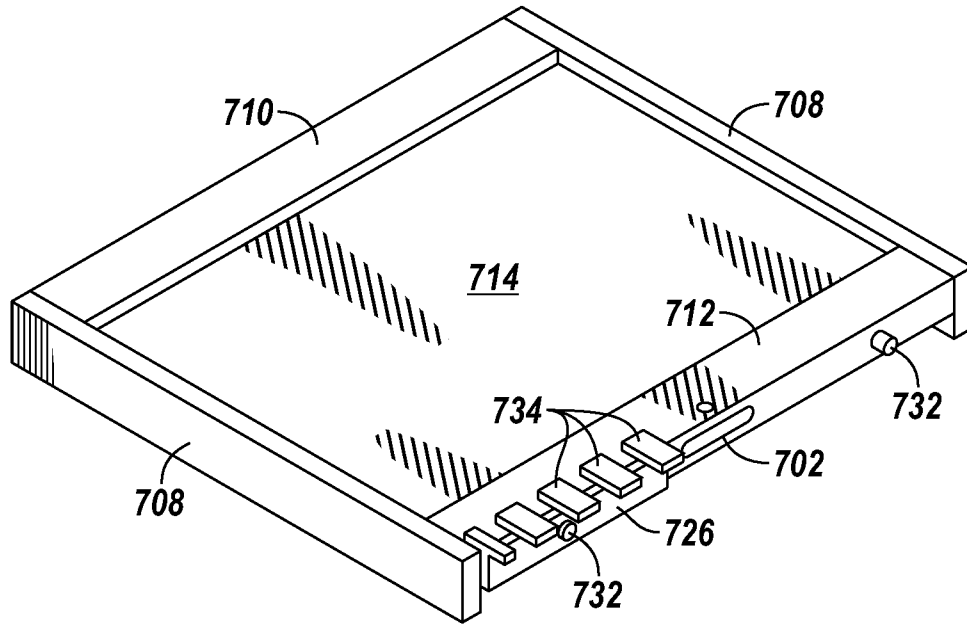

**FIG. 8**

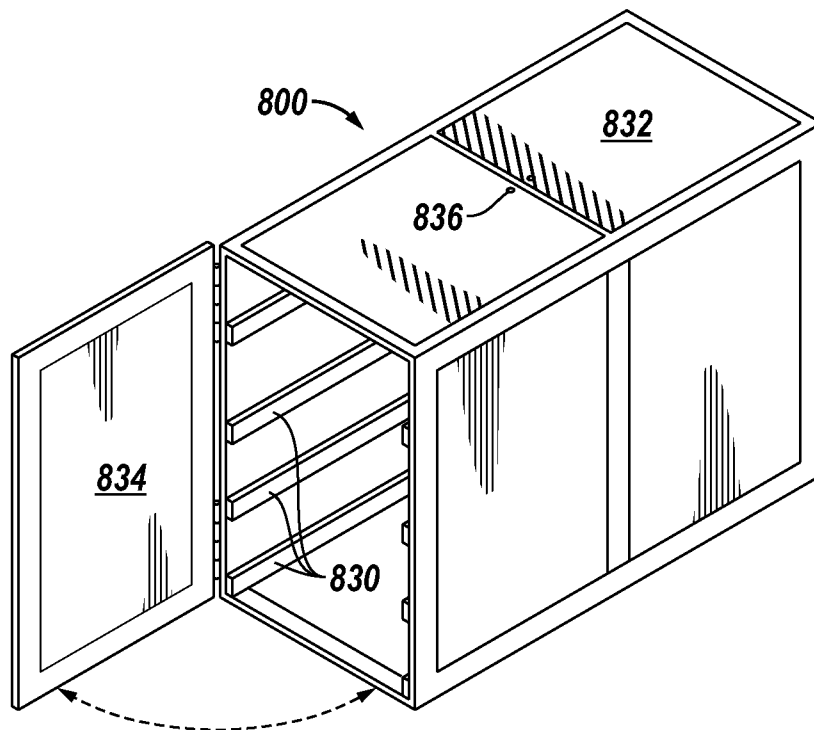

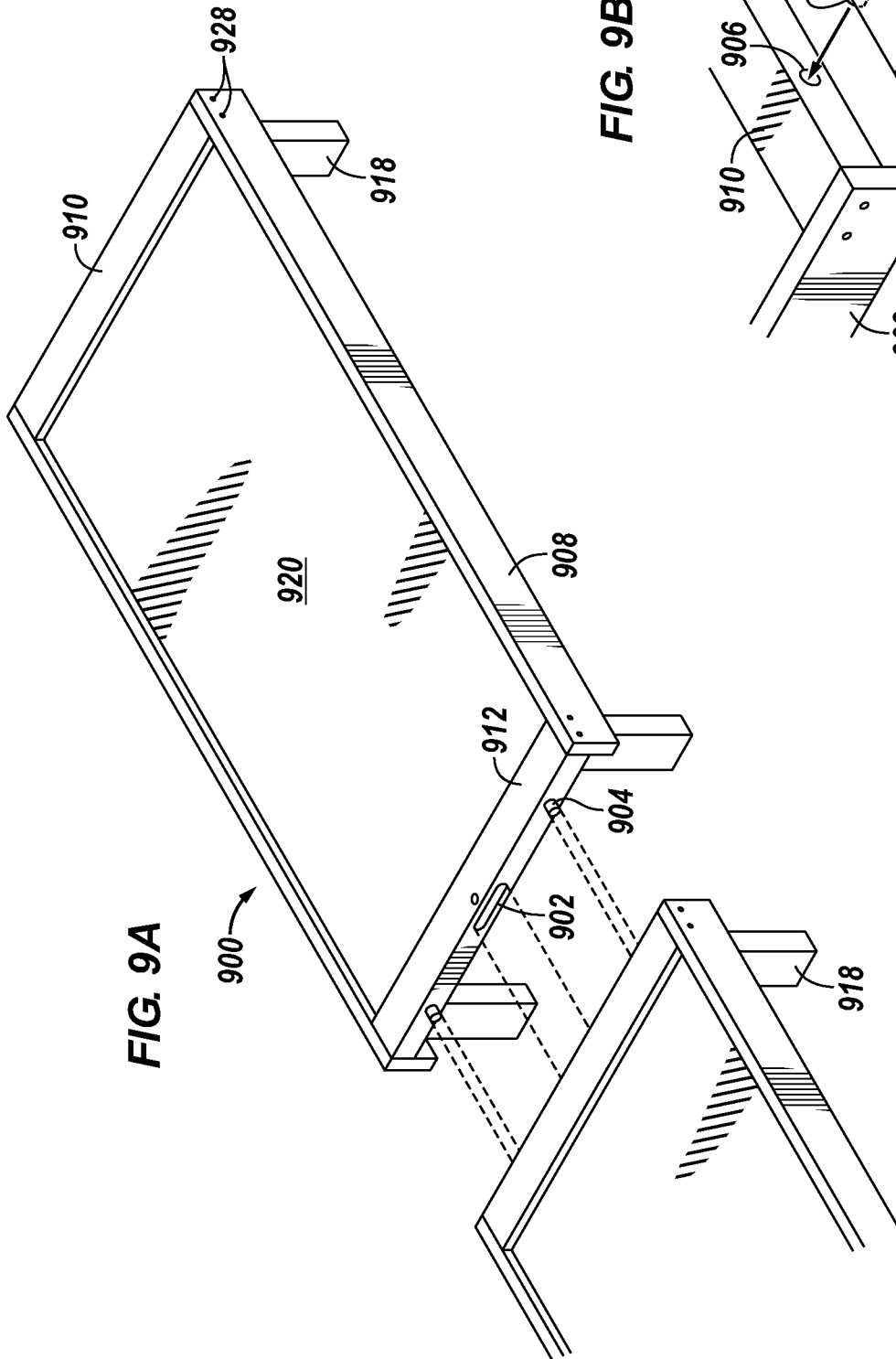
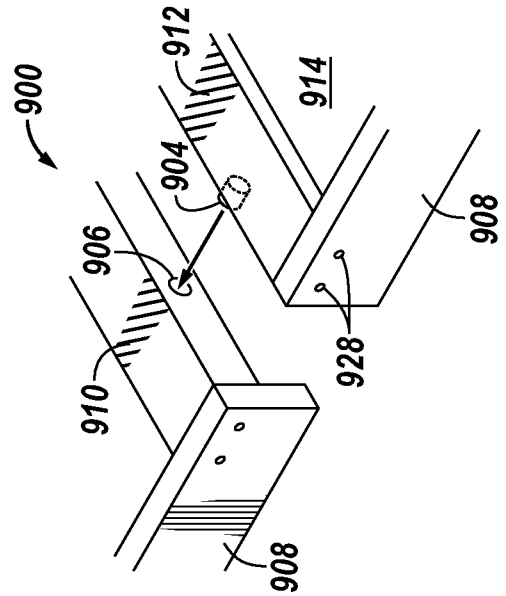
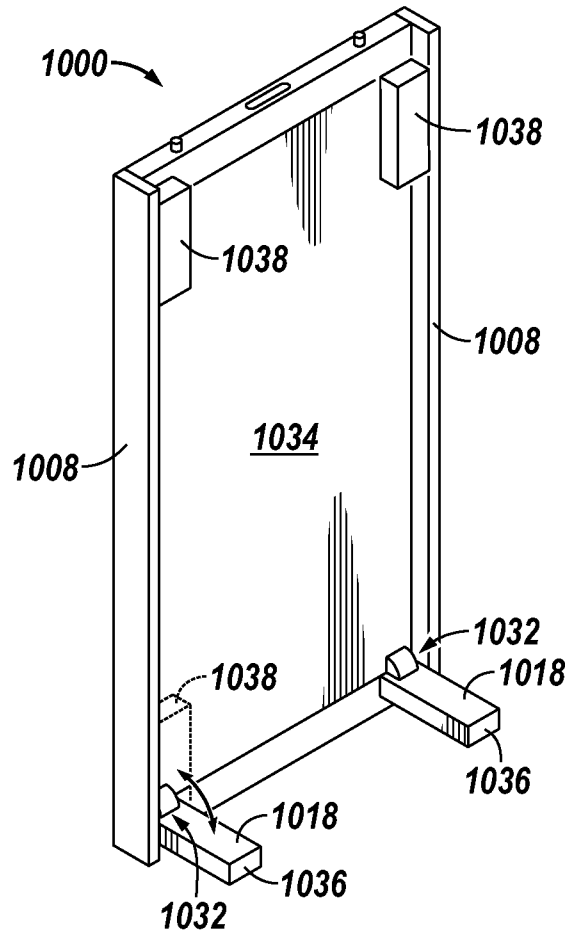

FIG. 9B



**FIG. 10**



**FIG. 11**

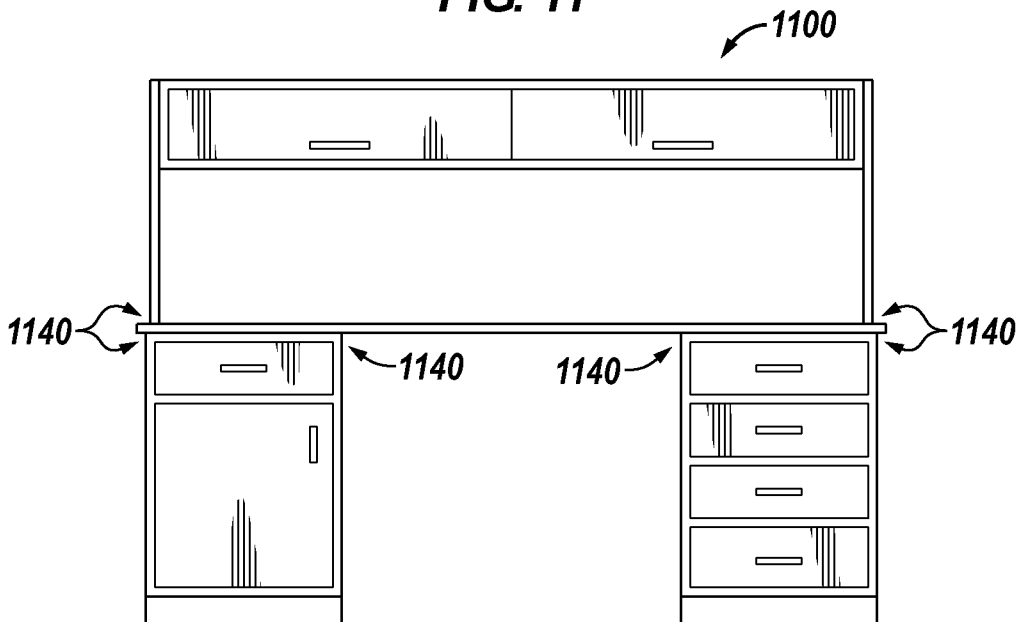

**FIG. 12**

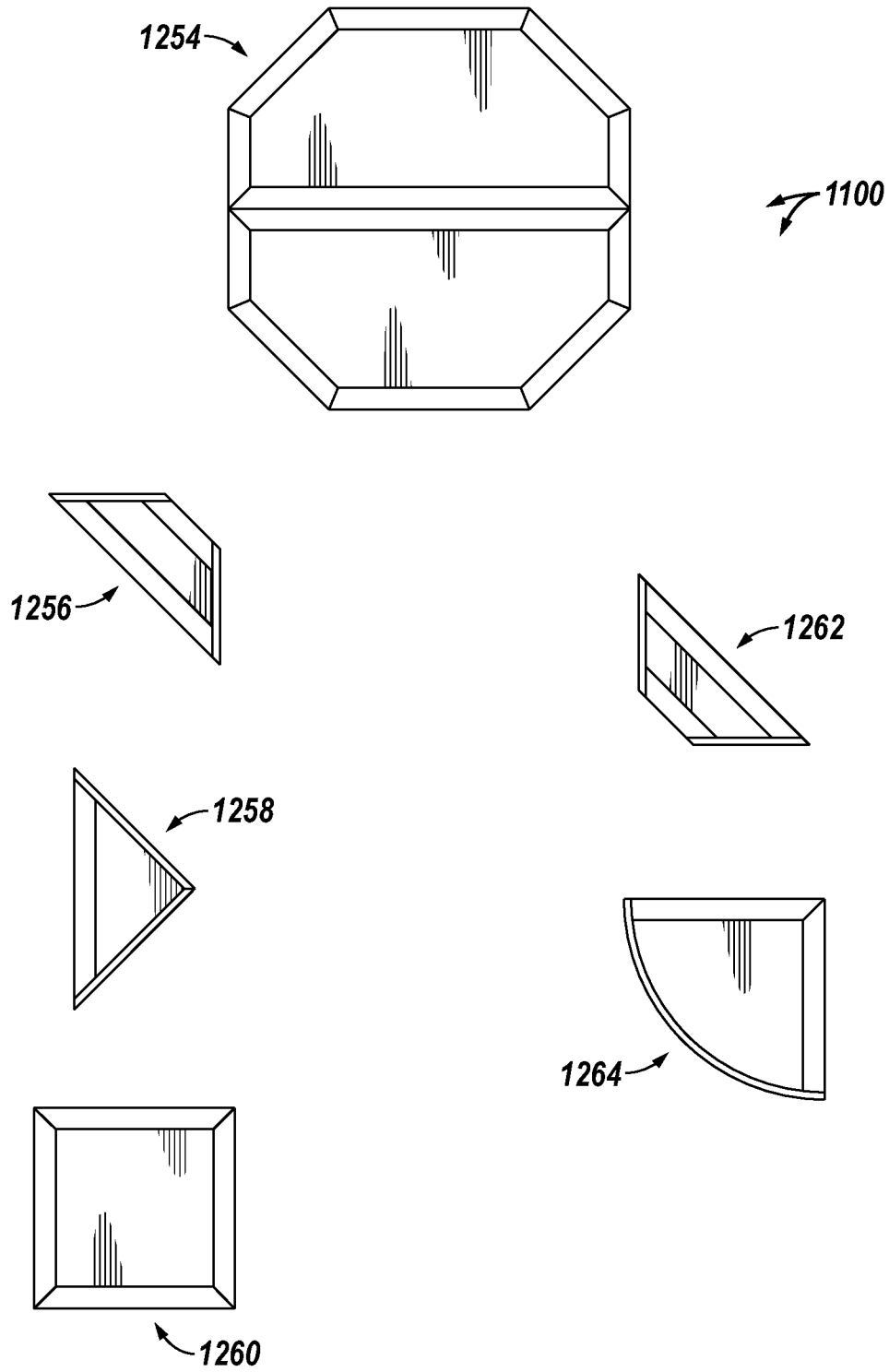
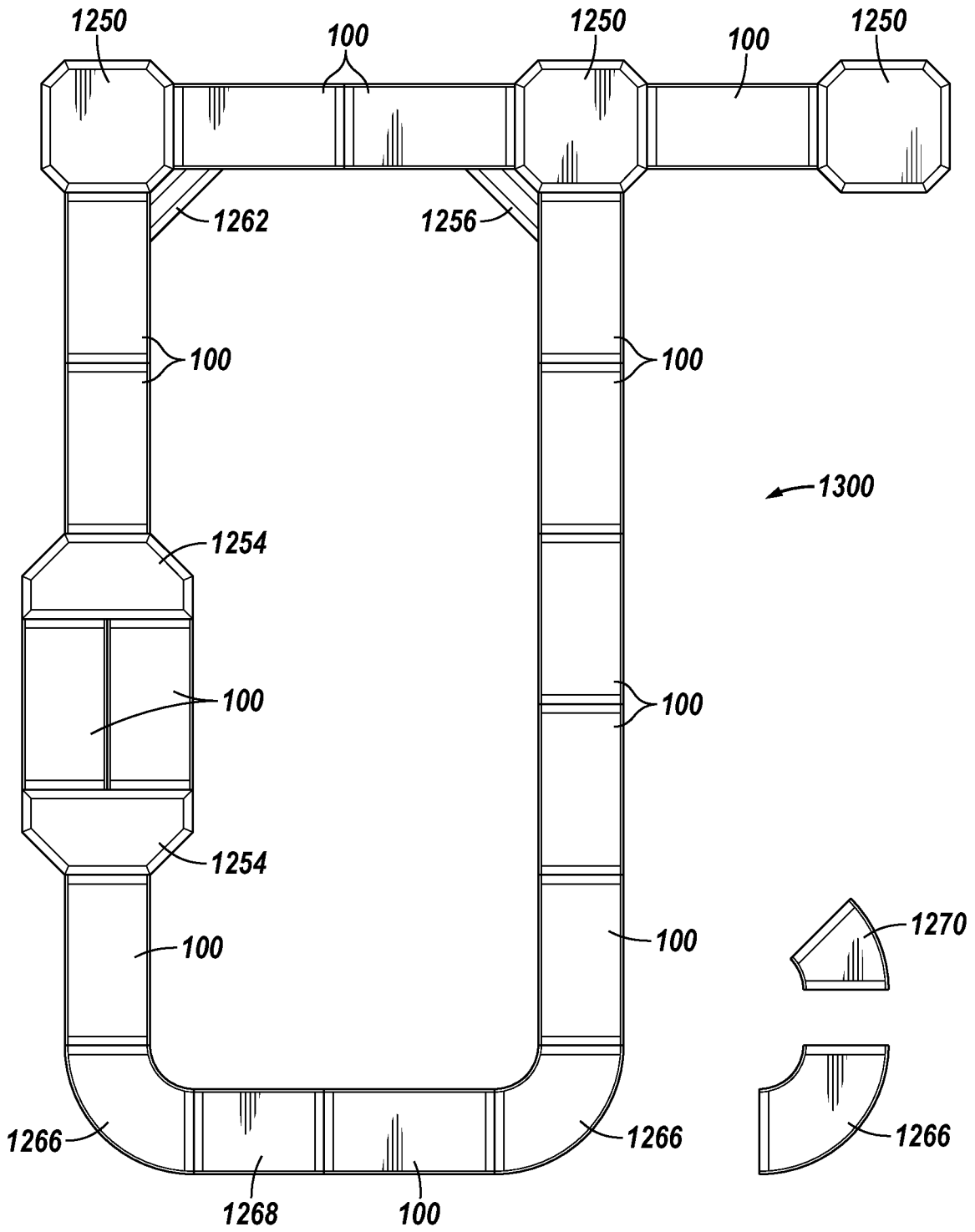
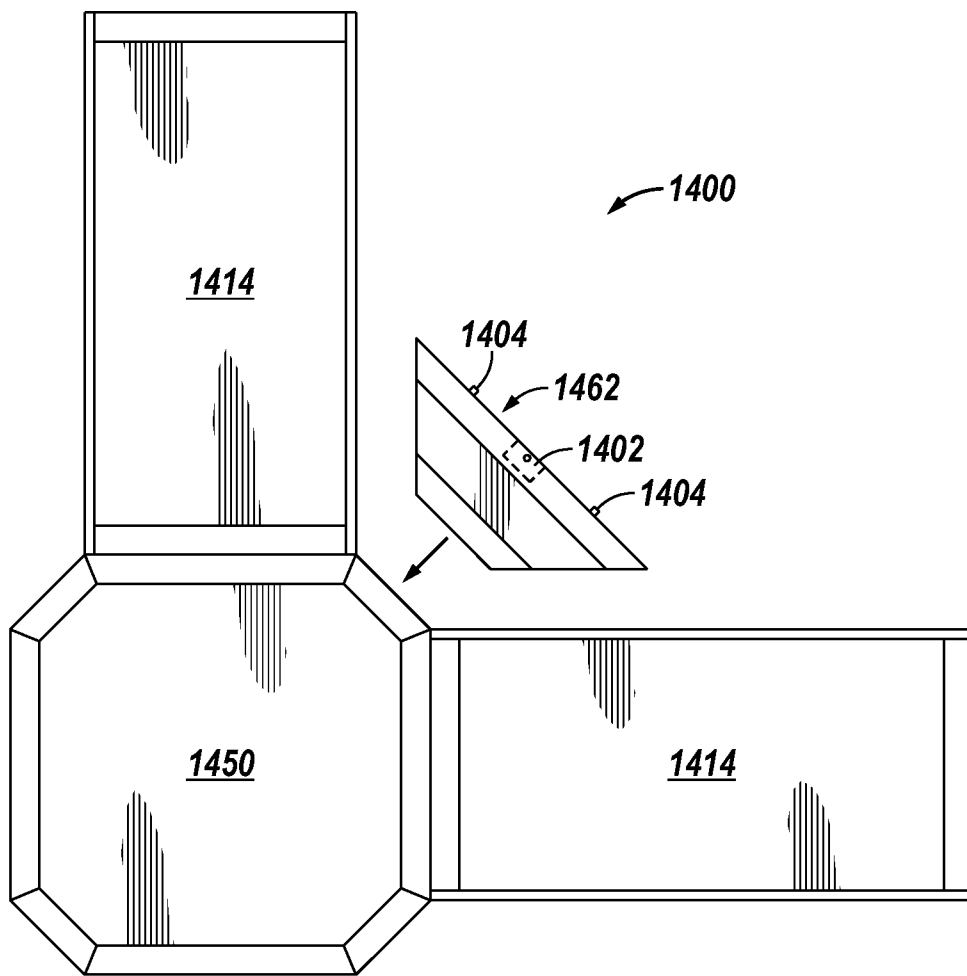

FIG. 13



**FIG. 14**



**FIG. 15**

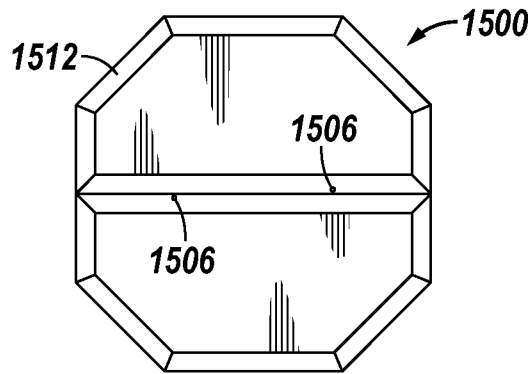

**FIG. 16**

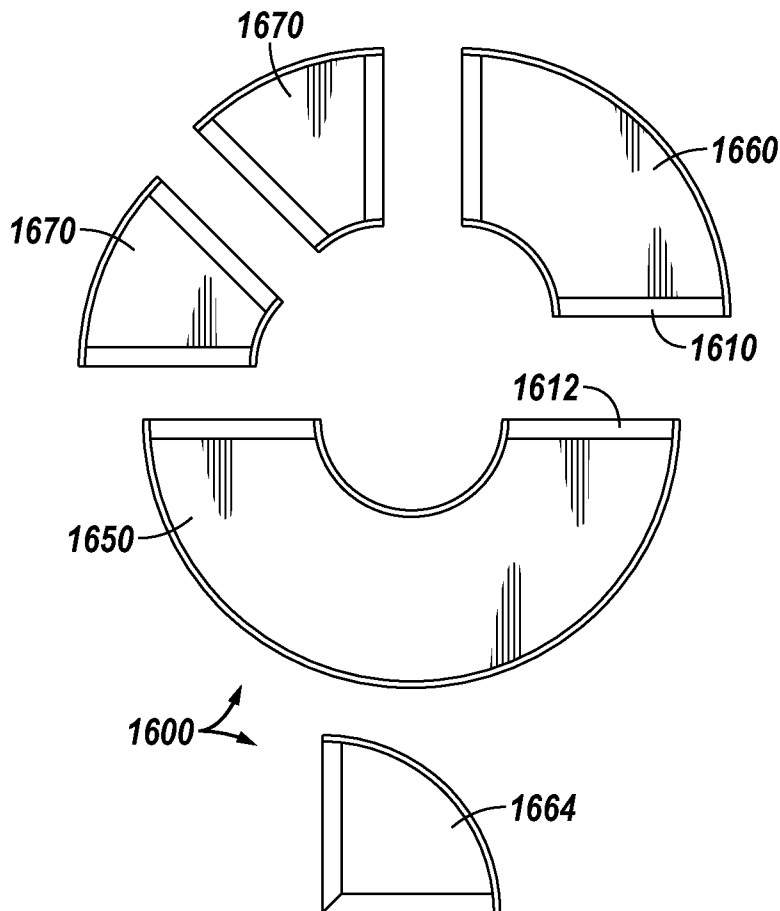

**FIG. 17**

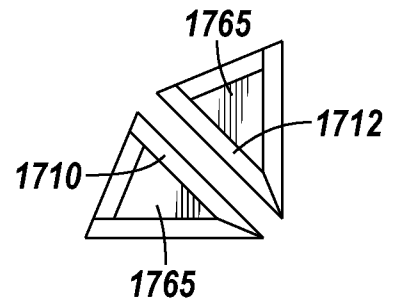

**FIG. 18**

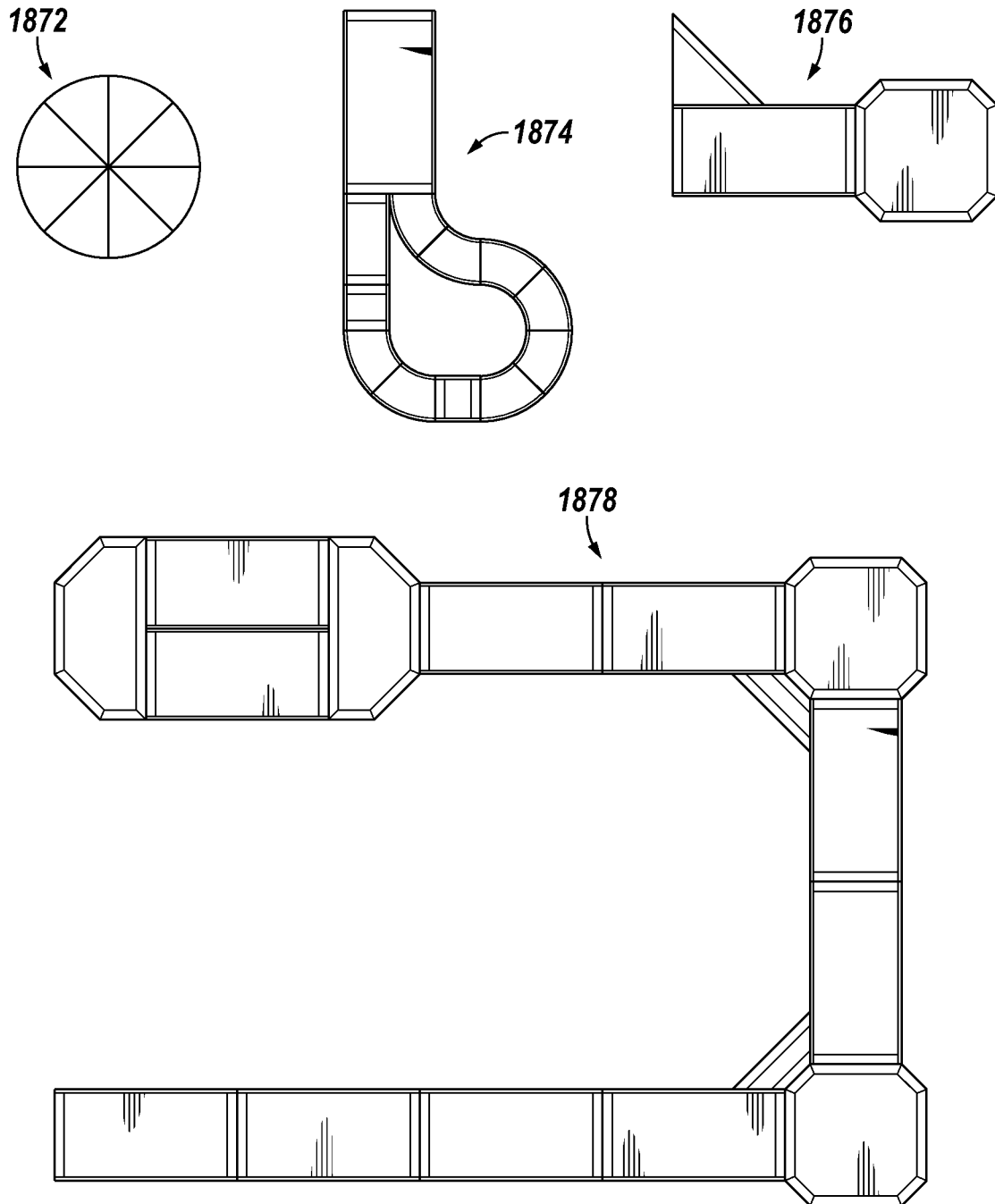

**FIG. 19A**

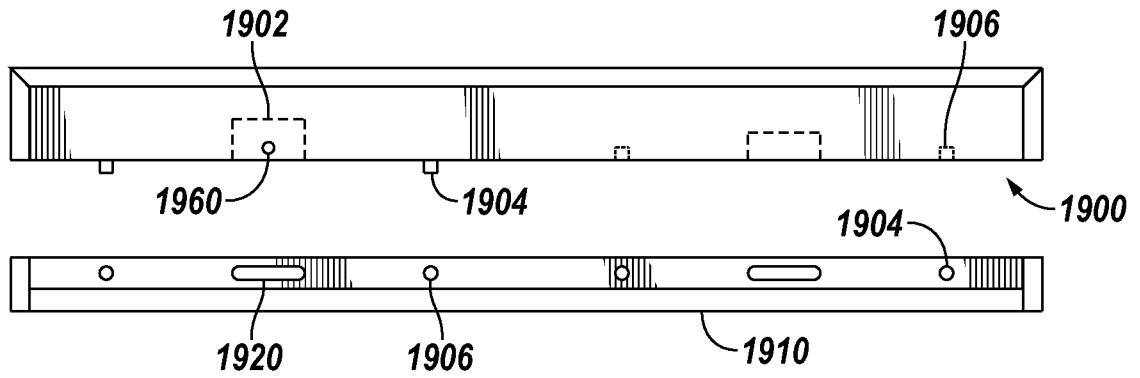

**FIG. 19B**

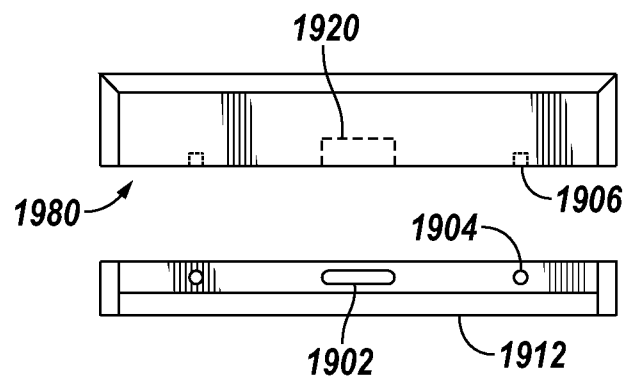

**A. CLASSIFICATION OF SUBJECT MATTER**

A47B 7/02(2006.01)i, F16B 12/24(2006.01)i, A47B 3/08(2006.01)i

According to International Patent Classification (IPC) or to both national classification and IPC

**B. FIELDS SEARCHED**

Minimum documentation searched (classification system followed by classification symbols)

A47B 7/02; A47B 1/04; A47B 27/00; A47C 1/12; B23P 11/00; A63D 15/00; A47B 17/00; F16B 12/24; A47B 3/08

Documentation searched other than minimum documentation to the extent that such documents are included in the fields searched

Korean utility models and applications for utility models

Japanese utility models and applications for utility models

Electronic data base consulted during the international search (name of data base and, where practicable, search terms used)

eKOMPASS(KIPO internal) &amp; Keywords: furniture, table, dowel, cam locking, module, railroad

**C. DOCUMENTS CONSIDERED TO BE RELEVANT**

Category*	Citation of document, with indication, where appropriate, of the relevant passages	Relevant to claim No.
X	US 5536078 A (NOVIKOFF, LEON) 16 July 1996 See column 7 line 61-column 8 line 20, column 10 line 30-column 11 line 20, and figures 6,17.	1,3-12,15-20
Y		2,13,14
Y	US 4436342 A (NILSON et al.) 13 March 1984 See column 1 line 64-column 2 line 8 and figure 2.	2,13,14
A	US 6729243 B2 (ANNAS, TIMOTHY L.) 04 May 2004 See column 2 line 43-column 4 line 44, column 6 lines 24-37, and figures 3,7.	1-20
A	US 2012-0103235 A1 (SUMMERVILLE, AARON) 03 May 2012 See paragraphs [0027]-[0029] and figure 1.	1-20
A	US 2009-0305802 A1 (KUNTZ, MONTGOMERY), 10 December 2009 See abstract, paragraphs [0025]-[0031], and figure 3.	1-20

 Further documents are listed in the continuation of Box C. See patent family annex.

\* Special categories of cited documents:

"A" document defining the general state of the art which is not considered to be of particular relevance

"E" earlier application or patent but published on or after the international filing date

"L" document which may throw doubts on priority claim(s) or which is cited to establish the publication date of citation or other special reason (as specified)

"O" document referring to an oral disclosure, use, exhibition or other means

"P" document published prior to the international filing date but later than the priority date claimed

"T" later document published after the international filing date or priority date and not in conflict with the application but cited to understand the principle or theory underlying the invention

"X" document of particular relevance; the claimed invention cannot be considered novel or cannot be considered to involve an inventive step when the document is taken alone

"Y" document of particular relevance; the claimed invention cannot be considered to involve an inventive step when the document is combined with one or more other such documents, such combination being obvious to a person skilled in the art

"&amp;" document member of the same patent family

Date of the actual completion of the international search

21 November 2013 (21.11.2013)

Date of mailing of the international search report

**21 November 2013 (21.11.2013)**

Name and mailing address of the ISA/KR

 Korean Intellectual Property Office  
 189 Cheongsa-ro, Seo-gu, Daejeon Metropolitan City,  
 302-701, Republic of Korea

Facsimile No. +82-42-472-7140

Authorized officer

KIM, Jin Ho

Telephone No. +82-42-481-8699



**INTERNATIONAL SEARCH REPORT**

Information on patent family members

International application No.  
**PCT/US2013/057348**

Patent document cited in search report	Publication date	Patent family member(s)	Publication date
US 5536078 A	16/07/1996	US 5472269 A US 5536078 A	05/12/1995 16/07/1996
US 4436342 A	13/03/1984	None	
US 6729243 B2	04/05/2004	CA 2419098 A1 US 2003-0192459 A1	16/10/2003 16/10/2003
US 2012-0103235 A1	03/05/2012	None	
US 2009-0305802 A1	10/12/2009	None	