

(19)
(12)

(KR)
(B1)

(51) 。 Int. Cl.7
F24F 1/00

(45)
(11)
(24)

2003 10 08
10-0400740
2003 09 24

(21) 10-2000-0083907
(22) 2000 12 28

(65)
(43)

2002-0054728
2002 07 08

(73)

20 LG

(72)

105 1004

1 303-2401

120 102-905

1 244-12

3 151-1420 3 202

42-60

2 202-1515 4

1630-4 1501

105-908

9-905

(74)

:

(54)

, , 가 , 가 가

4

1
2
3
4

/ /

10: 10a:
20: 20a:
30:

가 , 1 , 가
 (T1) 10 15 가 (T2) 80 100 가 ,
 (T2') 60 80 가 (T3) 40 50 가 (T4) 8
 10 가
 / / / 가
 (1) (2)가
 가 (4)가 (3) 가 (2)
 가 (3) (5) (3)
 (4) 가 (4)
 가 가 가

1

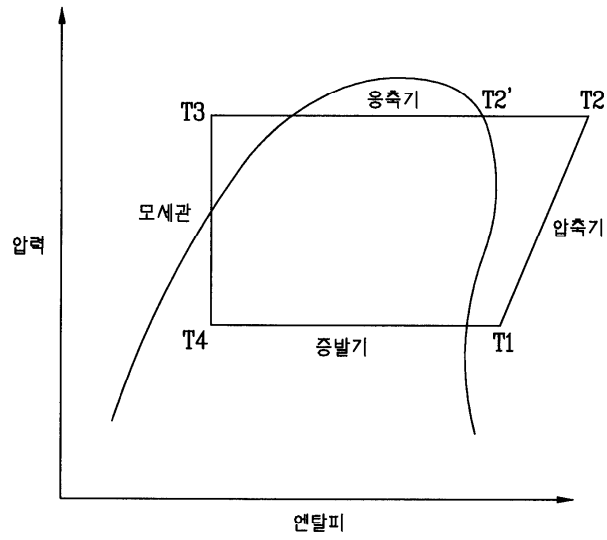

2

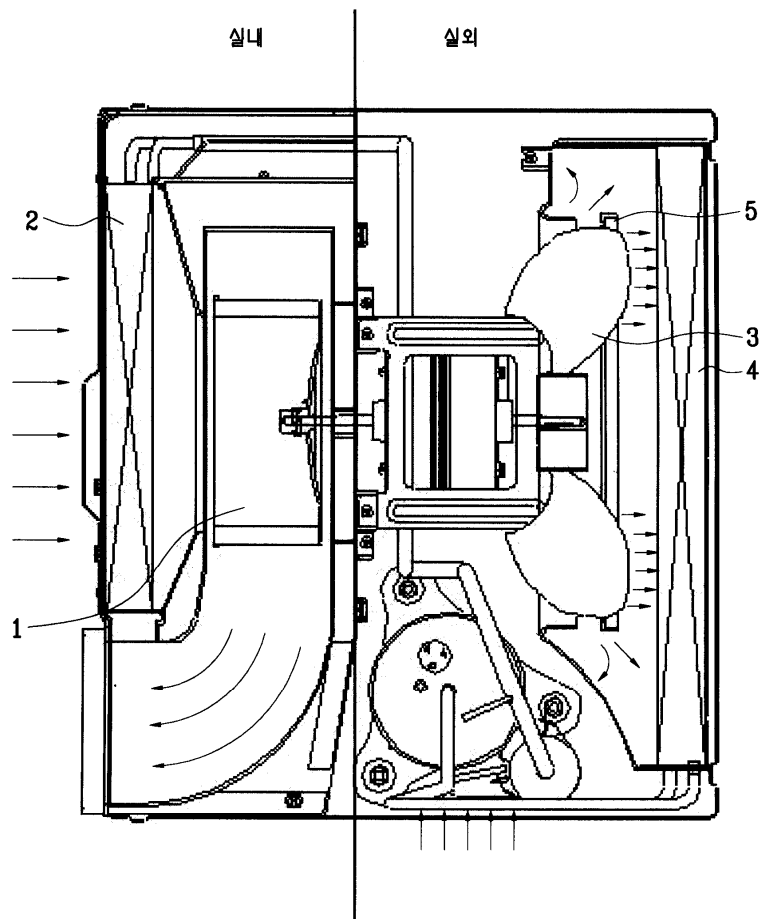

3

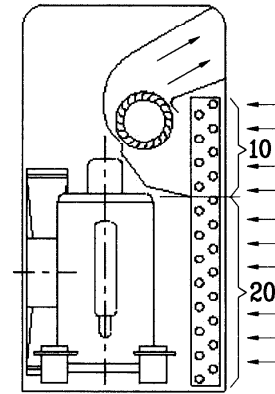
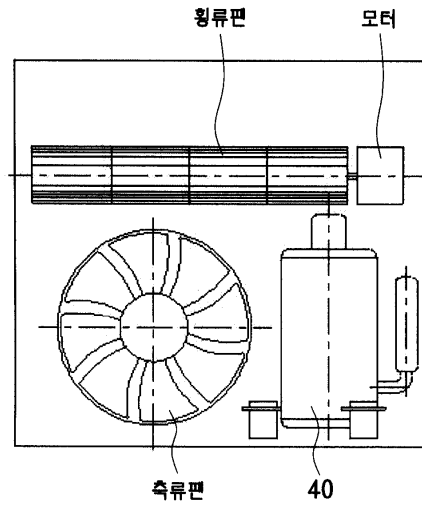
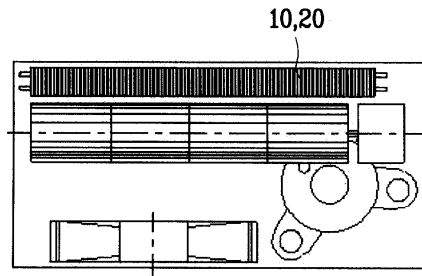

4

