

(19)  
(12)

(KR)  
(Y1)

(51) 。 Int. Cl. <sup>7</sup>  
B65D 21/00

(45)  
(11)  
(24)

2002 07 22  
20 - 0282412  
2002 07 05

(21) 20 - 2002 - 0013653  
(22) 2002 05 01

(73) 489 - 1 101 1404

(72) 489 - 1 101 1404

:  
가 :

(54) 가 (茶)

가 (茶) , (茶)가 1 2  
가 2 (茶) 3 가  
(茶) (茶)

가 , 1 2  
2 2 3 가 , 2 3  
(茶) 가 (茶) 가 가  
(茶) (茶)

2

. . 1 . 2 . . . 가 . 3 . 2 . 3 .

1

2

3

4

5

6

7

8

100 :

10 :

11 : 1

11 - 1 : 1

12 : 2

12 - 2 : 2

13 : 1

13 - 1 : 2

13 - 2 : 3

14 :

14 - 1 : 2

14 - 2 : 3

15 : 가

20 : 2

30 : 3

40 : 3

40 - 2 : 3

가 (茶) , (茶)가 1 2  
가 가 2 3 가  
(茶) (茶)  
, (茶) (茶)  
, (茶) (茶)  
(茶) 가 (茶)  
, 가 가  
, (茶) 1 2 가 2 3 3  
가 , 2 3 가 가 (茶)  
가 (茶) (茶)  
, , 1 (11) 1 (11)  
- 2) , (11 - 2) 2 (14 - 1)가 2  
(20)가 , 2 (20) 2 (12)  
가 가 (13, 13 - 1, 13 - 2) , 2 (12)  
2 (12 - 2) (12 - 2) 3  
(14 - 2)가 3 (30)가 , 3 (30) 3 (40)  
3 (13 - 2)가  
, 가 (茶)

- 1
- 2
- 3
- 4
- 5
- 6
- 7
- 8

1 (11-1) 8 (12) 2 (12) 1 (11) 2 (12) 1 (11) 1 (11-1) 2  
 (12) (12-2) (14-1, 14-2)가 1 (11) 2 (20) 3 (12) 3 (4  
 (30)가 , 2 (20) 3 가가 (30) 2 (12) 3 (4  
 0) .

1, 2, 3, 4 1 (11) (14) (10) ,  
 1 (11) 2 (20)가 ,  
 , 2 (20) 2 (12) (14-1)가 .  
 , (10) 1 (11) 2 (12)

, 2 (12) 1 (11) 2 (20)

, 5, 6, 7 2 (12) 3 (40) 1 (11)

8 (100) (美)  
 가가 .

15 가 , 100 가  
 (茶)

(茶) 가 (茶) (茶) (茶)  
 , , 가 (茶) (茶)

(57)

1.

(茶) , 1 (11) (14) (10) , 1 (11)  
 (14)가 1 2 (11-1)가 , 1 (11-1)  
 (20)가 가가 2  
 ,  
 2 (12) 2 (12-2) , (12-2)  
 (14-2)가 3 (30)가 , 3 (12-2)  
 30) 3 (40) 3 (13-2)가 ( )  
 가 (茶) .

2.

1 , 2 (12) 2 (12-2)가 , 2  
 (12-2) 3 (14-2)가 3 (30)가 (11)  
 , 3 (30) 3 (40) ( 1 (11)  
 2 (12) 3 (40)) 가  
 (茶) .

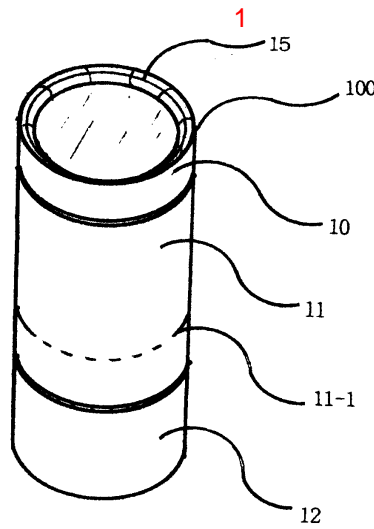

2

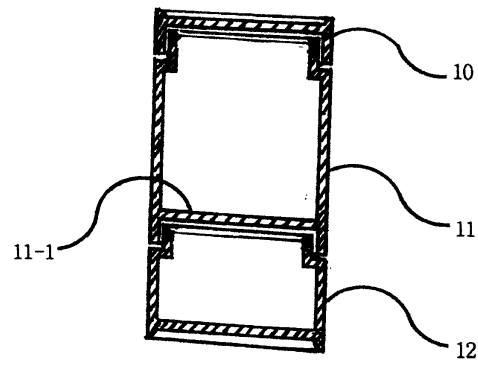

3

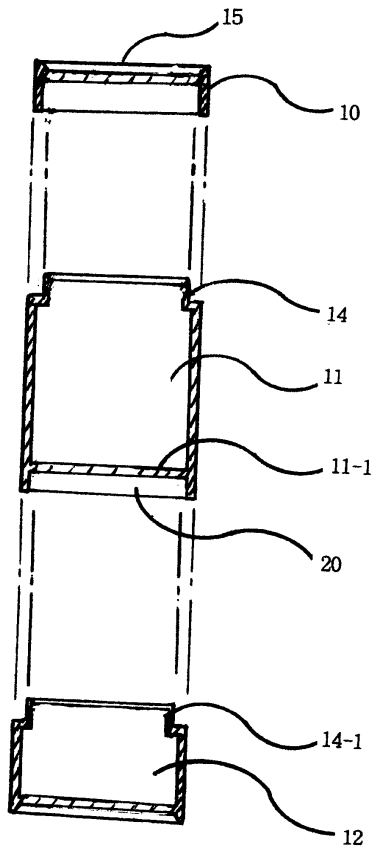

4

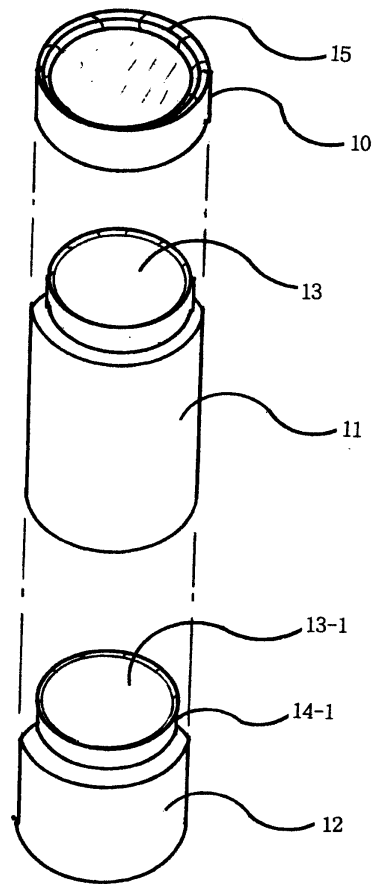

5

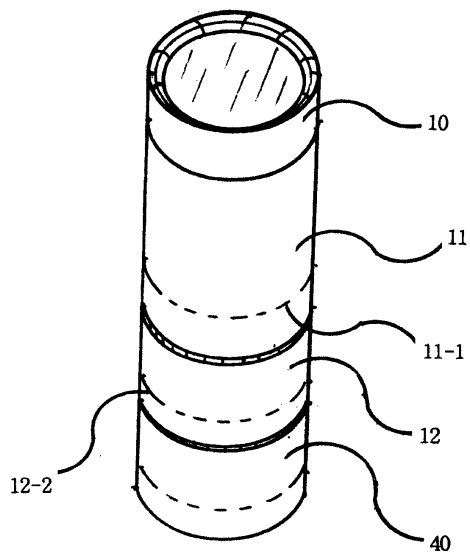

6

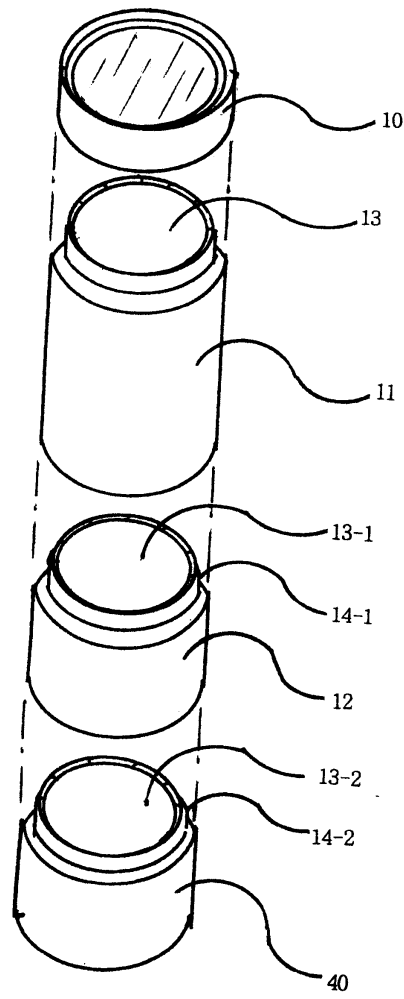

7

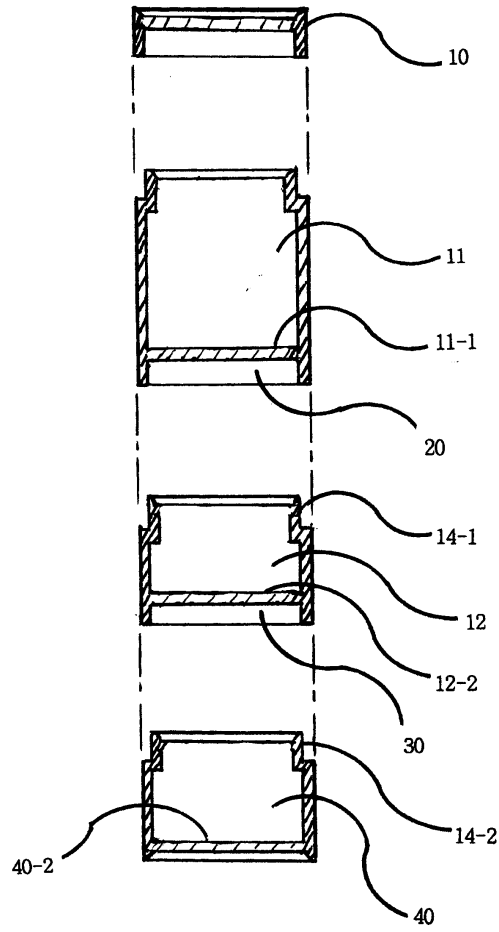

8

