

Oct. 31, 1950

H. H. SHAFFER
REMOVABLE JOURNAL BOX

2,528,393

Filed Feb. 5, 1948

3 Sheets-Sheet 1

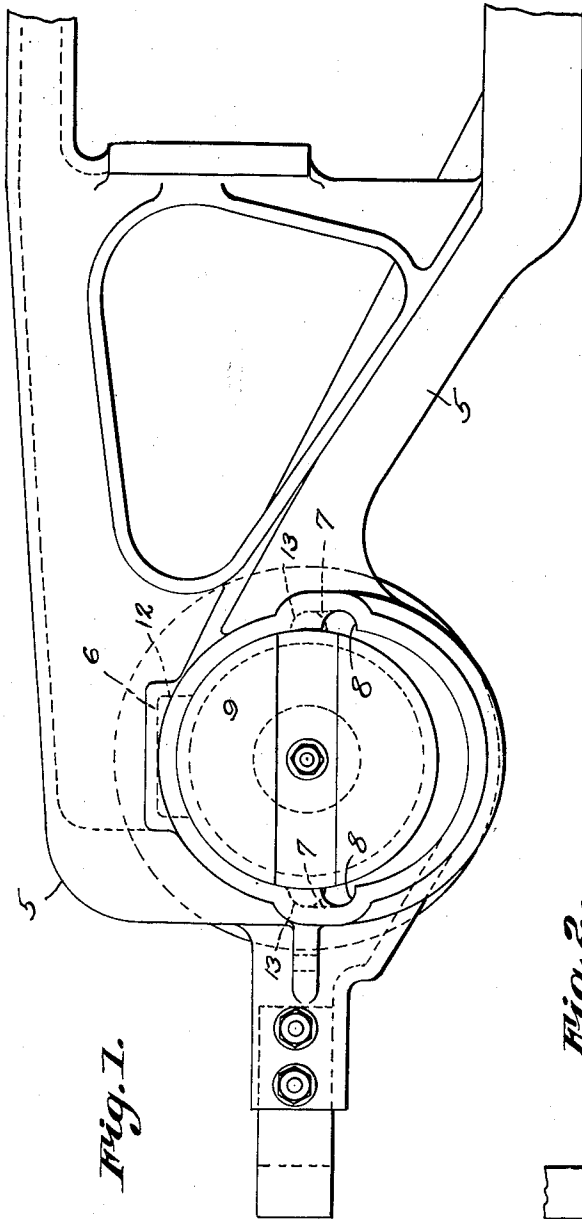

Fig. 1.

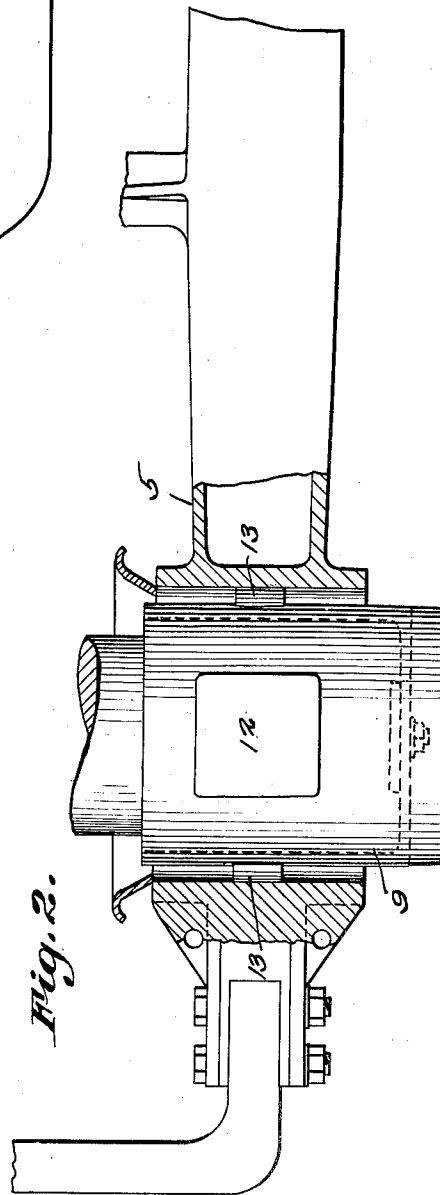

Fig. 2.

H. H. Shaffer

INVENTOR

BY *Calnow & Co.*
ATTORNEYS.

Oct. 31, 1950

H. H. SHAFFER
REMOVABLE JOURNAL BOX

2,528,393

Filed Feb. 5, 1948

3 Sheets-Sheet 2

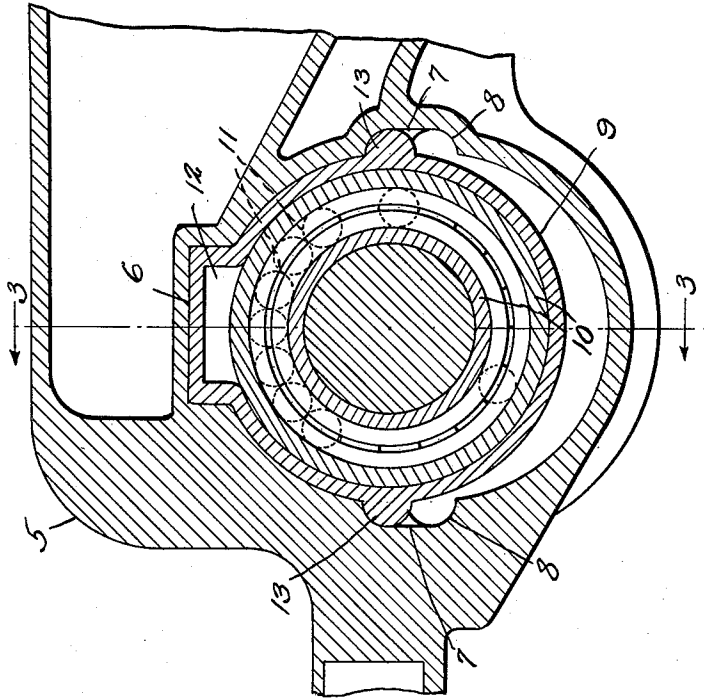

Fig. 4.

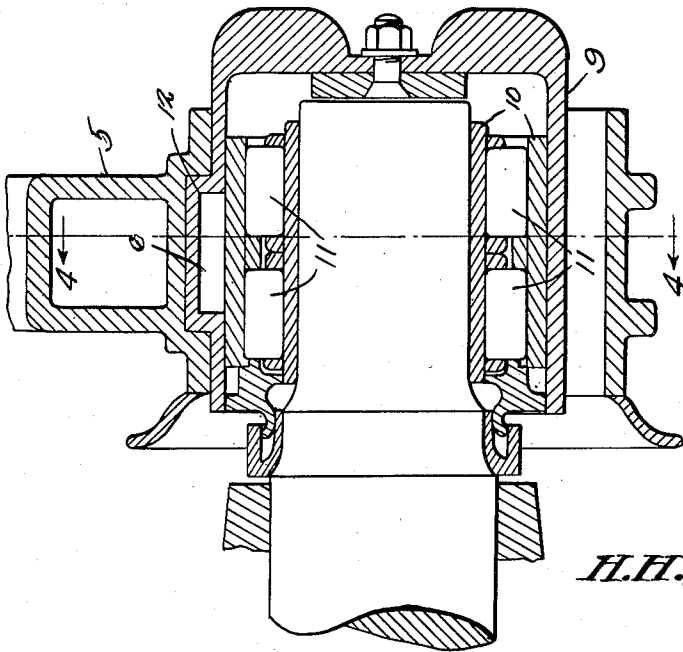

Fig. 3.

H. H. Shaffer

INVENTOR

BY *Chas. W. Co.*
ATTORNEYS.

Oct. 31, 1950

H. H. SHAFFER
REMOVABLE JOURNAL BOX

2,528,393

Filed Feb. 5, 1948

3 Sheets-Sheet 3

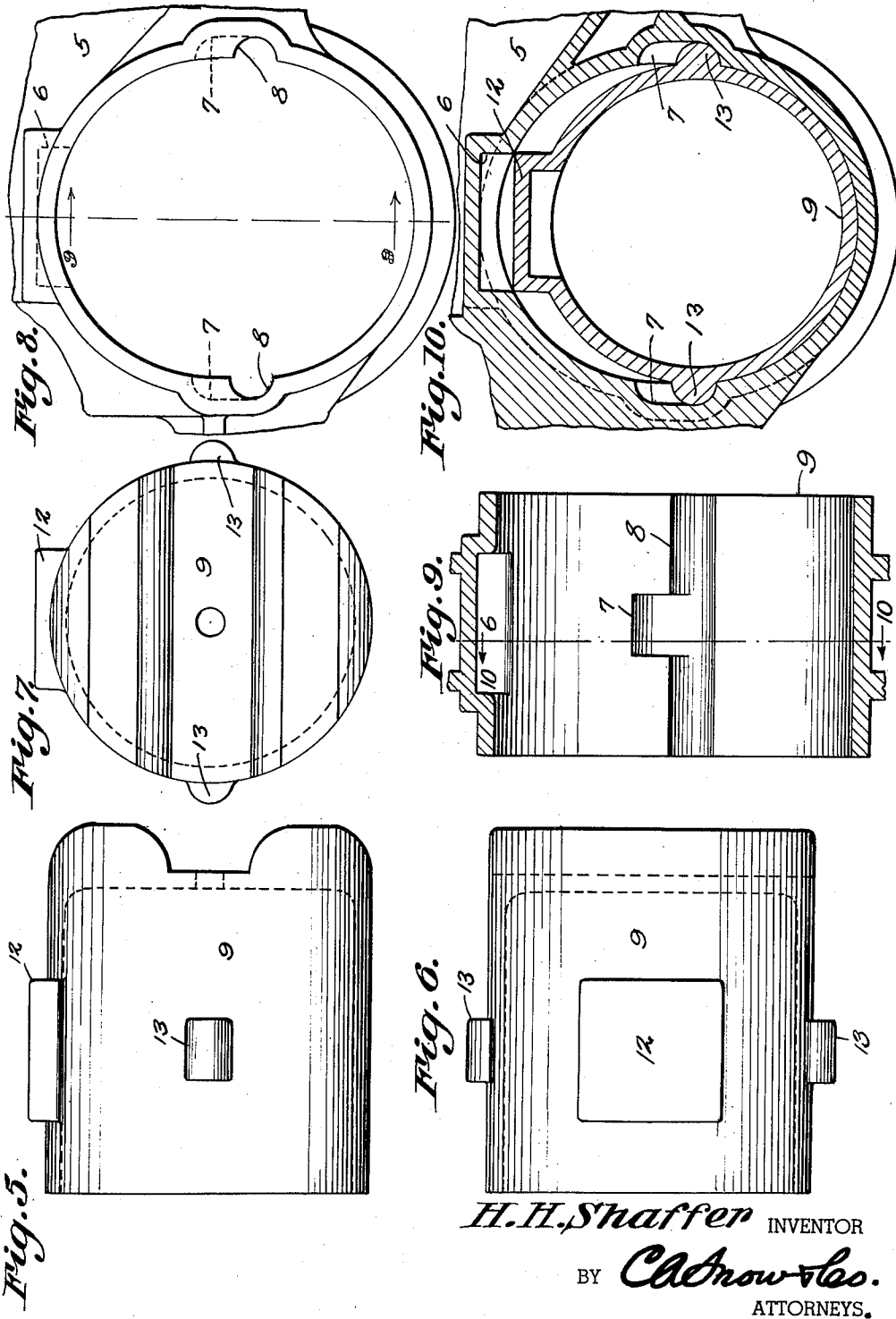

H. H. Shaffer INVENTOR

BY *Chenoweth*
ATTORNEYS.

UNITED STATES PATENT OFFICE

2,528,393

REMOVABLE JOURNAL BOX

Harvey H. Shaffer, Berwick, Pa.

Application February 5, 1948, Serial No. 6,372

1 Claim. (Cl. 105—220)

1

This invention relates to railway rolling stock, and more particularly to the journal box construction thereof.

The primary object of the invention is to provide a removable journal box designed so that it may be lubricated by an oil well, or the device may be used with grease as a sealed unit, whereby the journal box may be packed with grease prior to mounting or the application of the journal box to the axle.

Another object of the invention is to provide a journal box which can be removed from the truck without the necessity of removing the car body, thereby appreciably decreasing the time and cost of repair and lubrication of journal boxes to a minimum.

An important object of the invention is to provide a journal box which will be held in place by the weight of the rolling stock supported thereby, eliminating the use of bolts or nuts, commonly employed in securing and adjusting journal boxes with respect to the axles.

With the foregoing and other objects in view which will appear as the description proceeds, the invention consists of certain novel details of construction and combinations of parts, hereinafter more fully described and pointed out in the claim, it being understood that changes may be made in the construction and arrangement of parts without departing from the spirit of the invention as claimed.

Referring to the drawings:

Figure 1 is a side elevational view of one end of a truck side frame of railway rolling stock, illustrating a journal box, constructed in accordance with the invention, as mounted thereon.

Fig. 2 is a plan view thereof, a portion of the truck frame being shown in section.

Fig. 3 is a vertical sectional view through the journal box illustrating a car axle as fitted therein taken on line 3—3 of Fig. 4.

Fig. 4 is a vertical sectional view taken on line 4—4 of Fig. 3.

Fig. 5 is a plan view of the journal box.

Fig. 6 is a side elevational view thereof.

Fig. 7 is an end elevational view of the journal box.

Fig. 8 is an end elevational view illustrating the journal box opening formed at one end of the side frame of a truck frame.

Fig. 9 is a sectional view taken on line 9—9 of Fig. 8.

Fig. 10 is a vertical sectional view on line 10—10 of Fig. 9 with the members 5 and 9 assembled.

2

Referring to the drawings in detail, the reference character 5 indicates one end of a truck side frame, forming a part of railway rolling stock.

As clearly shown by Fig. 8 of the drawings, the truck side frame is formed with journal box openings which are formed with upper recesses 6 and lateral vertical grooves 7, the grooves 7 and recesses 6 being formed in the wall of the journal box opening.

The grooves 7 have one of their respective walls cut away as at 8 providing entrances to the vertical grooves 7, the cut-away portions 8 extending inwardly from the outer edge of the journal box opening.

The journal box forming the subject matter of the present invention is of the roller bearing type and is adapted for use with practically any type of roller bearing now in production.

As shown, the journal box includes a substantially circular housing 9 in which the roller races 10, are mounted, the roller races supporting the rollers 11.

The housing 9 is somewhat smaller in diameter than the diameter of the opening in the truck frame, and has extending upwardly from the upper surface thereof, an enlargement 12 adapted to fit closely within the recess 6, the formation of the enlargement 12 being such that it will move readily into the recess 6 and be held therein by the weight of the car body, supported thereon.

Extending from opposite sides of the housing 9, are wide lugs 13 which have rounded outer edges designed to fit within the grooves 7. On positioning the journal box, it is to be understood that the truck frame will be elevated by means of a suitable jack, whereupon the lugs 13 will fall opposite to the cut-away portions 8. With the weight of the car body removed, the journal box may now be readily slid from the opening within the truck side frame. Removal of the journal box may be desirable in order to repair or replace worn parts in the bearings of the journal, or it may be necessary to repack the bearings. The journal may after repairs or repacking, be readily positioned on the axle of the rolling stock, in such a way that when the lifting jack is removed, the weight of the car body will cause the truck frame to move downwardly, the lugs passing into the vertical grooves 7, while the upper recess 6 accommodates the enlargement 12 preventing twisting of the journal box.

Having thus described the invention, what is claimed is:

In combination, a truck frame having a circular journal box opening, the wall of the journal box

opening having a recess formed therein adjacent to the top of the journal box opening, the wall of said journal box opening having vertical grooves with cut-away portions extending from the lower ends of the grooves to the outer edge of the opening, a circular journal box having lugs extending from the sides thereof movable in the grooves and the cut-away portions, and an enlargement formed on the top of the journal box, fitted into the recess and retaining the journal box in position within the journal box opening.

HARVEY H. SHAFFER.

REFERENCES CITED

The following references are of record in the file of this patent:

UNITED STATES PATENTS

Number	Name	Date
1,272,824	McCord -----	July 16, 1918
1,343,618	Doerr -----	June 15, 1920
1,636,767	Dreibuss -----	July 26, 1927
2,047,248	Bachman -----	July 19, 1936