



US 20080017063A1

(19) **United States**

(12) **Patent Application Publication**

Martinez-Tovar et al.

(10) **Pub. No.: US 2008/0017063 A1**

(43) **Pub. Date: Jan. 24, 2008**

(54) **TITANIUM SEMICONDUCTOR BRIDGE IGNITER**

Publication Classification

(76) Inventors: **Bernardo Martinez-Tovar**,
Albuquerque, NM (US); **Martin C. Foster**,
Placitas, NM (US)

(51) **Int. Cl.**
F42C 19/12 (2006.01)
(52) **U.S. Cl.** **102/202.7**

Correspondence Address:
CANTOR COLBURN, LLP
55 GRIFFIN ROAD SOUTH
BLOOMFIELD, CT 06002

(57) **ABSTRACT**

A titanium semiconductor bridge igniter (10, 10') has a substrate (12, 12') on which is carried a pair of spaced-apart pads (18a, 18b) connected by a bridge (20). The pads (18a, 18b) and bridge (20) are made of a layer of polysilicon (22) or crystalline silicon (22') covered by a layer of titanium (24). Metal lands (26a, 26b) overlie the pads (18a, 18b) but leave the bridge (20) exposed so that it can be placed in contact with an energetic material charge (42). A method of stabilizing the titanium semiconductor bridge igniter (10, 10') against temperature-induced variations in electrical resistance of bridge (20) includes heating the titanium semiconductor bridge igniter (10, 10') to an elevated temperature, e.g., from about 37° C. to about 250° C.

(21) Appl. No.: **11/829,526**
(22) Filed: **Jul. 27, 2007**

Related U.S. Application Data

(63) Continuation of application No. 11/555,990, filed on Nov. 2, 2006, now abandoned.
Continuation of application No. 09/470,343, filed on Dec. 22, 1999, now abandoned.

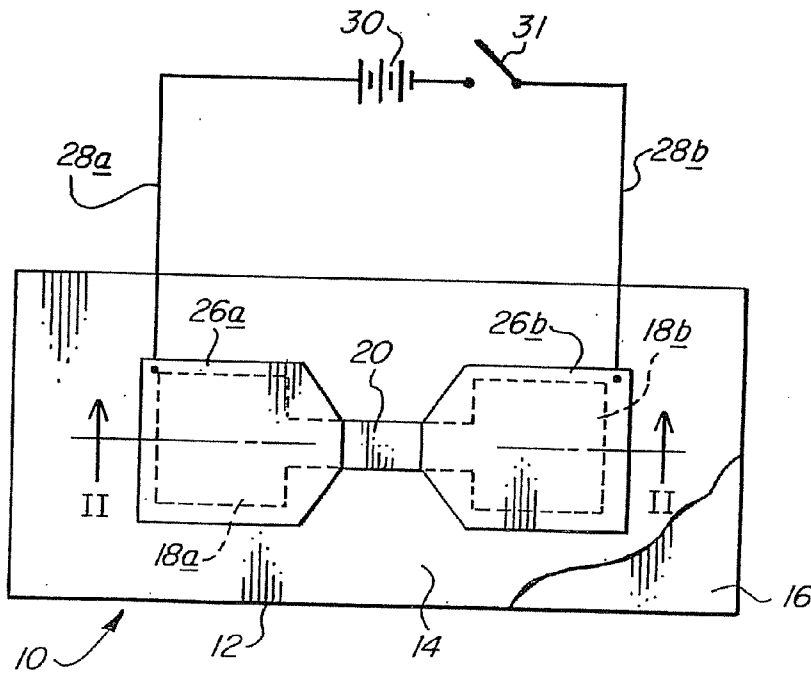

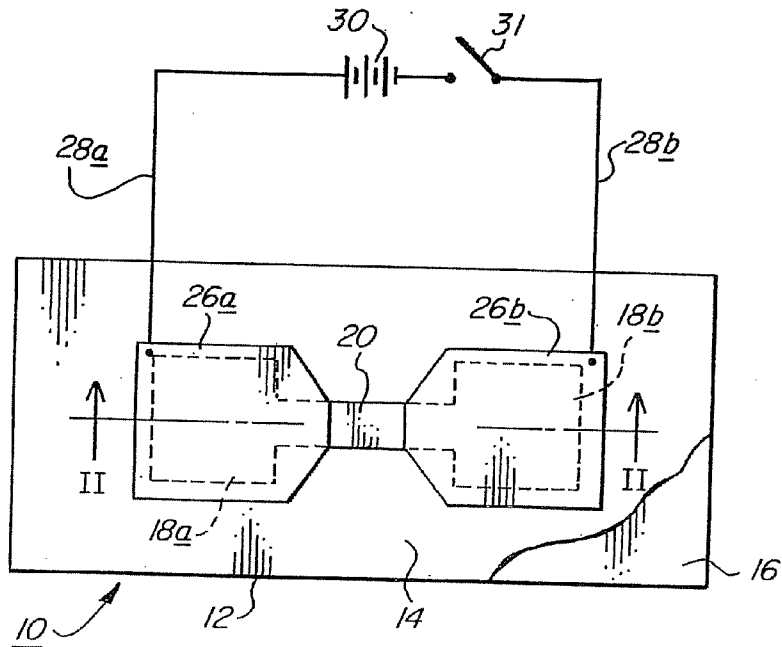

FIG. 1

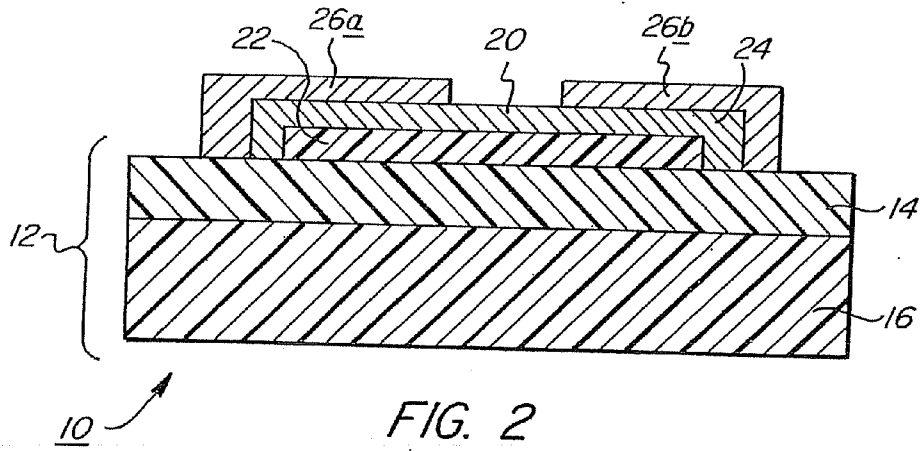

FIG. 2

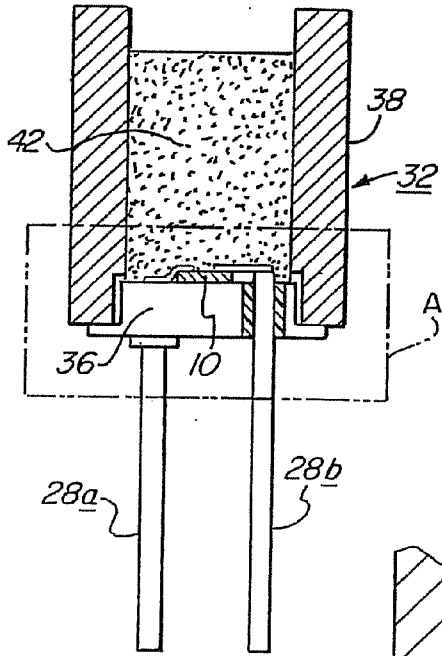

FIG. 3

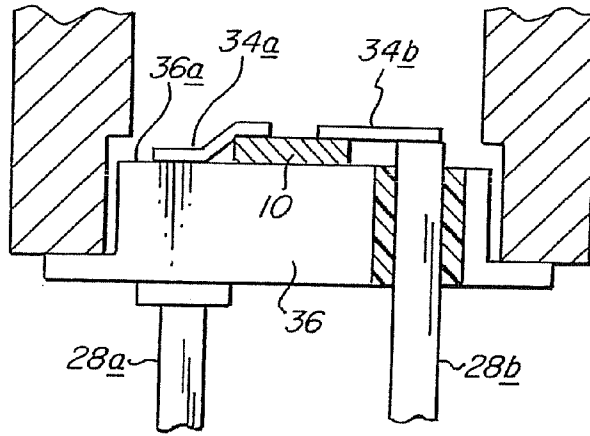

FIG. 3A

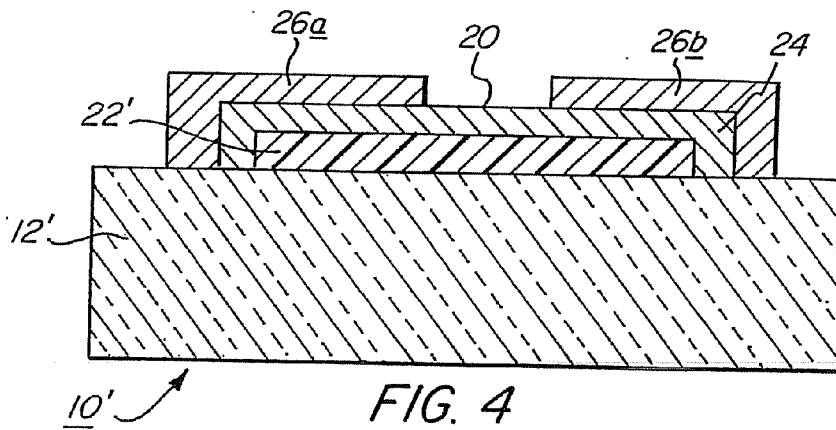

FIG. 4

TITANIUM SEMICONDUCTOR BRIDGE IGNITER**CROSS-REFERENCE TO RELATED APPLICATIONS**

[0001] This application is a continuation of co-pending patent application Ser. No. 11/555,990, filed Nov. 2, 2006, and entitled "Titanium Semiconductor Bridge Igniter", which is a continuation of patent application Ser. No. 09/470,343, filed Dec. 22, 1999, and entitled "Titanium Semiconductor Bridge Igniter", now abandoned.

BACKGROUND OF THE INVENTION

[0002] 1. Field of the Invention

[0003] The present invention relates to a titanium semiconductor bridge igniter of a type used to initiate an energetic material by passing an electric current through the semiconductor bridge to generate therefrom a plasma which ignites the energetic material.

[0004] 2. Related Art

[0005] U.S. Pat. No. 4,708,060, issued Nov. 24, 1987 to R. W. Bickes, Jr., et al., and entitled "Semiconductor Bridge (SCB) Igniter" discloses a semiconductor bridge igniter comprising an electrical material having a negative temperature co-efficient of electrical resistivity at elevated temperature. The electrical material comprises doped silicon, is mounted on a non-electrically conducting substrate, and defines a pair of spaced pads connected by a bridge. The area of each of the pads is much larger than the area of the bridge, the resistance of which must be less than about 3 ohms. Metallized layers, such as aluminum lands, overlie the pads. An energetic material is placed in contact with the semiconductor bridge and the passage of a low level of electric current through the semiconductor bridge is attained by connecting the lands in an electrical circuit. The electric current is said to result in the formation of plasma from the bridge material, which, with a resultant convective shock effect, initiates the energetic material.

[0006] U.S. Pat. No. 4,976,200, issued Dec. 11, 1990 to D. A. Benson et al., and entitled "Tungsten Bridge for the Low Energy Ignition of Explosive and Energetic Materials". This patent discloses a device similar to the above-mentioned '060 patent, but one in which the doped silicon semiconductor bridge of the '060 patent is replaced by a composite bridge comprised of a first layer of silicon in contact with the insulating substrate and a second layer overlying the first layer, the second layer being tungsten. One difficulty with the tungsten thin-film bridge of U.S. Pat. No. 4,976,200 is the difficulty and expense of applying the thin film of tungsten to the silicon bridge by the chemical vapor deposition process suggested in the patent.

[0007] Devices such as the silicon semiconductor bridge igniter of U.S. Pat. No. 4,708,060 and the tungsten-coated semiconductor bridge of U.S. Pat. No. 4,976,200 require intimate contact of, and significant pressure between, the bridge and the energetic material they are intended to ignite, in order to provide reliable initiation. If intimate contact and significant pressure are not maintained between the bridge and the energetic material, the device may be rendered unreliable and/or the activation energy must be increased in order to avoid a decrease in initiation reliability of the device.

SUMMARY OF THE INVENTION

[0008] In accordance with the present invention there is provided a titanium semiconductor bridge device comprising a substrate and an electrical bridge structure disposed on the substrate and electrically insulated therefrom. The bridge structure comprises a layer of a material having a negative coefficient of electrical conductivity at temperatures above ambient temperature and having disposed thereover a layer of titanium, the bridge structure comprising a bridge section extending between and connecting spaced-apart pad sections, each pad section being of larger area than the bridge section. A pair of electrically conductive lands each overlies a respective one of the pad sections and is spaced apart from the other land to leave the bridge section exposed.

[0009] In one aspect of the invention, the titanium semiconductor bridge device further comprises a pair of electrical leads, each connected to a respective one of the electrically conductive lands.

[0010] The present invention also provides one or more of the following features, separately or in combination: the titanium semiconductor bridge device may further include a source of electrical energy connected to each of the electrical leads to define an electrical circuit extending from one lead to one of the aluminum lands, through the bridge section, thence to the other aluminum land and to the other electrical lead; the substrate may comprise silicon on which is disposed a layer of silicon dioxide on which is disposed the electrical bridge structure and, alternatively, the substrate may comprise sapphire.

[0011] Other aspects of the invention provide one or more of the following features, separately or in combination: the material having a negative coefficient of electrical conductivity may comprise crystalline silicon or polysilicon, in which case, the polysilicon may be an undoped film; and the titanium semiconductor bridge device may be disposed in contact with an energetic material charge contained within the header of an igniter assembly. The silicon may be pure, or small impurities may be present without degrading the effectiveness of the invention.

[0012] In a method aspect of the present invention, there is provided a method for making the titanium semiconductor bridge igniter, which method includes preconditioning the titanium semiconductor bridge igniter by heating it to an elevated temperature to stabilize it against temperature-induced variations in bridge electrical resistance, for example, a method in which the igniter is heated to an elevated temperature of from about 37° C. to about 250° C., e.g., from about 100° C. to 250° C.

BRIEF DESCRIPTION OF THE DRAWINGS

[0013] FIG. 1 is a schematic plan view of a titanium semiconductor bridge igniter in accordance with one embodiment of the present invention;

[0014] FIG. 2 is a schematic view in cross section taken along line II-II of FIG. 1;

[0015] FIG. 3 is a schematic cross-sectional view of an igniter assembly utilizing one embodiment of a titanium semiconductor bridge igniter of the present invention;

[0016] FIG. 3A is a view, enlarged relative to FIG. 3, of approximately the portion of FIG. 3 enclosed by the rectangular area A; and

[0017] FIG. 4 is a view corresponding to FIG. 2 showing a second embodiment of the present invention.

DETAILED DESCRIPTION OF THE
INVENTION AND SPECIFIC EMBODIMENTS
THEREOF

[0018] The titanium semiconductor bridge igniter of the present invention provides a significant improvement over the prior art semiconductor bridge igniters described above. Generally, it is desired that semiconductor bridge igniters provide highly reliable initiation of energetic material while requiring less energy input, and yet not be sensitive to unintended, stray stray currents. It is further desirable that such devices be relatively simple and inexpensive to manufacture and lend themselves to mass production techniques.

[0019] In addition to the drawbacks noted above, the tungsten-covered silicon bridge of U.S. Pat. No. 4,976,200 poses another difficulty due to the fact that the melting point of tungsten, 3695° Kelvin (“° K”), is higher than the vaporization temperature (2628° K.) of silicon. This impedes the effectiveness of the plasma formed from the silicon in igniting the energetic material, because the tungsten layer of the bridge overlies the silicon and is therefore interposed as a solid layer between the vaporizing silicon and the energetic material charge against which the semiconductor bridge igniter is placed. The resulting absorption of energy by the solid tungsten lessens the efficiency of tungsten bridge devices.

[0020] The titanium semiconductor bridge igniter of the present invention utilizes a thin film of titanium deposited on the silicon bridge and thereby provides a product which is greatly superior to the tungsten-layered silicon bridge of U.S. Pat. No. 4,976,200. The melting point of titanium (1660° C.) is only slightly higher than that of silicon (1420° C.) and much lower than silicon’s vaporization point of 2628° K., so that when the bridge is activated by an electrical current, or an electrical discharge from a capacitor, the titanium layer interposed between the silicon bridge and the energetic material charge melts well before the silicon vaporizes at 2628° K. The molten titanium does not impede the plasma generated from the silicon bridge from impinging upon and igniting the energetic material charge against which the titanium semiconductor bridge igniter is placed.

[0021] Further, as the titanium thin film is heated, it reacts with oxygen and/or nitrogen present in the environment of the energetic material charge in an exothermic reaction which enhances the energy output of the vaporizing silicon bridge. Thus, reaction of the titanium with atmospheric oxygen and/or nitrogen enclosed within an igniter assembly supplements the energy derived from the electrical energy input to the titanium semiconductor bridge igniter to vaporize and generate a plasma from the silicon bridge. The titanium layer of the bridge therefore provides initiation of the energetic material charge at lower energy input to the device than do the silicon or tungsten/silicon semiconductor bridges of the two prior art patents noted above. Specifically, the use of a thin-film titanium overlayer as part of the bridge of the titanium semiconductor bridge igniter results in a lower input energy requirement for initiation than do identically sized semiconductor bridge igniters such as the silicon bridge of U.S. Pat. No. 4,708,060, or the tungsten/silicon bridge of U.S. Pat. No. 4,976,200.

[0022] Not only does the titanium silicon bridge of the present invention require lower energy input for initiation than a comparably sized bridge of the prior art but, because the titanium enters into an exothermic reaction with atmospheric oxygen and/or nitrogen, the energy output is supplemented and the requirement for high-pressure intimate contact of the titanium semiconductor bridge igniter with the energetic material charge is lessened. Thus, because of its pyrophoric activity, the titanium layer in the bridge generates hot particles as the silicon bridge heats up and vaporizes, the hot particles further aiding in reliability of initiation of the energetic material.

[0023] In terms of manufacturing, the titanium layer can be readily deposited on the titanium semiconductor bridge igniter by standard vacuum deposition techniques, such as evaporation or sputtering. The titanium layer can be produced in the desired patterns by standard semiconductor fabrication techniques which readily lend themselves to mass production of the igniters.

[0024] One drawback associated with the use of titanium is that the bridge electrical resistance of the igniter increases with increasing temperature, and part of this increase appears to be irreversible, i.e., return to lower temperature does not return the material to lower resistance. Without wishing to be bound by any particular theory, it is believed that oxidation of the surface of the titanium and/or oxygen impurities within the titanium film causes the irreversible increase in electrical resistance. Therefore, titanium semiconductor bridge igniters containing a thin-film layer of titanium on a silicon bridge in accordance with the present invention, and which were subjected in transportation or use to high temperatures after leaving the factory, e.g., temperatures of about 37° C. to about 250° C., might offer a higher electrical resistance than that for which they were rated at the factory. However, this difficulty can be readily overcome simply by heating the devices after, or as part of, the manufacturing process in order to precondition them. Thus, if the titanium semiconductor bridge igniters are heated to a temperature of, for example, about 250° C., there will be no increase of resistivity of the igniters if they encounter temperatures up to 250° C. in storage, transportation or use. Generally, during the preconditioning step the igniters may be heated to, or close to, the highest temperatures they can sustain without risk of damage, in order to stabilize them against temperature-induced changes in bridge resistance.

[0025] Referring now to FIGS. 1 and 2, there is shown a titanium semiconductor bridge igniter 10 comprising a substrate 12. In the illustrated embodiment, substrate 12 is an insulator and comprises silicon 16 on which is disposed a silicon dioxide layer 14. (All the Figures are schematic and are not drawn to scale.) Pads 18a and 18b (FIG. 1) are connected to each other by a bridge 20. The pads 18a, 18b and bridge 20 are comprised, as shown in FIG. 2, of a polysilicon layer 22 surmounted by a thin-film titanium layer 24. Preferably, the titanium layer 24 should be deposited over the entirety of the polysilicon layer 22. Pads 18a, 18b and portions of bridge 20 adjacent thereto are surmounted by a pair of metal, e.g., aluminum, lands 26a, 26b. Any suitably conductive metal or combination of metals may be substituted for the aluminum of aluminum lands 26a, 26b; for example, gold, silver, chromium or other metals may be utilized. As shown in FIG. 1, aluminum (or other metal) lands 26a, 26b are connected by electrical leads 28a,

28b (FIG. 1) to a DC energy source **30** which may comprise a battery or other source of DC current, a capacitor or the like. A switch **31** is shown in the electrical circuit.

[0026] The titanium semiconductor bridge igniter **10** of FIGS. 1 and 2 is shown in FIG. 3 as a component of an igniter assembly **32** which is comprised of an electrically insulating header base **36**, which may be made of, for example, ceramic or glass. Header base **36** is, however, preferably made of metal for good thermal conductivity and is electrically insulated from the electrical leads passing through it, typically by glass insulation. In any case, header base **36** is contained within a receptacle **38**. Titanium semiconductor bridge igniter **10**, as best seen in FIG. 3A, is mounted on the top surface **36a** of header base **36**. Header base **36** has a pair of passageways (unnumbered) formed therein for the passage therethrough of electrical leads **28a**, **28b** (FIGS. 3 and 3A). The unnumbered passageways in header base **36** are sealed by a suitable sealant, as is well known in the art, in order to prevent the ingress of moisture, liquids or other contaminants therethrough. Electrical leads **28a**, **28b** are connected in electrical contact to the aluminum lands **26a**, **26b** of the titanium semiconductor bridge igniter **10** by wire bonds **34a**, **34b**. The ends of electrical leads **28a**, **28b** which emerge from header base **36** will be connected to a suitable source of electrical energy such as the DC energy source **30** of FIG. 1.

[0027] Receptacle **38** defines an enclosure within which is contained titanium semiconductor bridge igniter **10** and an energetic material charge **42** comprised of a compacted powder of energetic material, e.g., a pyrotechnic material such as zirconium potassium perchlorate. Any suitable energetic material may, of course, be used, such as titanium subhydride potassium perchlorate, lead azide or zirconium potassium perchlorate.

[0028] In use, upon closing of switch **31**, electrical current flows through the circuit established by leads **28a**, **28b** (FIGS. 2 and 3) aluminum lands **26a**, **26b** and, initially, titanium layer **24** of bridge **20**. Either the DC current or the discharge of a capacitor provides the requisite electrical energy. At room temperature the undoped polysilicon layer **22** exhibits high electrical resistance and the current flow is through the titanium layer **24**. As the undoped polysilicon layer **22** is heated by the joule heating of the titanium, its electrical resistance decreases due to its negative coefficient of electrical resistivity, which is characteristic of the material, until its resistivity equals, or is less than, that of the titanium layer **24**. At that point, most of the electric current, and therefore most of the energy, is passing through the polysilicon layer **22**. The titanium layer **24** of the bridge **20** becomes heated and melts before the polysilicon layer **22** of the bridge vaporizes to generate a plasma. Because the titanium layer **24** has melted, it does not interpose a solid barrier between the energetic material charge **42** and the plasma generated upon vaporization of the polysilicon layer **22** of bridge **20**. The silicon plasma therefore impinges directly upon the energetic material charge **42**. Further, the molten titanium will react with any oxygen or nitrogen present in an exothermic reaction which further contributes energy to the initiation of energetic material charge **42**. Therefore, effective and reliable initiation of energetic material charge **42** is attained.

[0029] The titanium semiconductor bridge igniter of the invention may be used in the same applications as known

semiconductor bridge igniters, for example, to initiate a charge to inflate automobile airbags or to initiate other larger explosive charges. The igniter assembly **32** will, in use, therefore be securely fastened by means (not shown) so as to cause the initiation of energetic material charge **42** to effectuate its intended purpose upon the passage of a suitable electric current through the circuitry schematically illustrated in FIG. 1.

[0030] FIG. 4 is a view corresponding to FIG. 2, but showing a semiconductor bridge igniter **10'** in accordance with another embodiment of the present invention. Titanium semiconductor bridge igniter **10'** utilizes a sapphire substrate **12'** in lieu of the substrate **12** of the FIG. 2 embodiment. Crystalline silicon layer **22'** replaces polysilicon layer **22**. All other components of the titanium semiconductor bridge igniter **10'** of FIG. 4 are identical to those of the FIG. 2 device and are identically numbered. Accordingly, the description thereof is not repeated here.

[0031] The following examples illustrate the benefits obtained by a particular embodiment of the present invention.

EXAMPLE 1

[0032] A titanium semiconductor bridge igniter as schematically illustrated in FIG. 1 was prepared using standard semiconductor processing equipment and techniques. The numerals utilized in FIGS. 1 and 2 are used in this example to help identify components of the titanium semiconductor bridge igniters tested. The titanium layer **24** was deposited by vacuum evaporation on an undoped polysilicon layer **22**. Immediately after cessation of deposition of the titanium layer, aluminum metallization was deposited without breaking the vacuum conditions in the evaporation chamber, in order to ensure a clean interface between the resultant aluminum lands **26a**, **26b** and titanium layer **24**. Conventional masking and etching techniques were employed to configure the polysilicon layer **22** and the titanium layer **24** in the "bow-tie" pattern illustrated in FIG. 1. The aluminum lands **26a**, **26b** are configured to expose the bridge **20**, but overlie the pads **18a**, **18b**. The exposed bridge **20** was **39** micrometers long by **78** micrometers wide. The titanium layer **24** had a thickness of 0.35 micrometers and the aluminum lands **26a**, **26b** had a thickness of 1.5 micrometers. The final tested resistance of the bridge **20** was 3 ohms. These parts were manufactured on a wafer, as is conventional, and the parts were then diced and mounted onto standard TO-46 headers substantially as illustrated in FIG. 3. Five-mil diameter aluminum wire was used for electrical leads **28a**, **28b** (FIGS. 1 and 3) and were thermosonically wire-bonded in electrical contact with aluminum lands **26a**, **26b** (FIGS. 1 and 2), as indicated by wire bonds **34a**, **34b** (FIG. 3). The parts were tested using a standard Sensit test for destructible parts: firing voltage being varied for each test firing based on analysis of preceding test firings, using an algorithm which determines firing statistics (mean firing voltage, standard deviation) with a relatively small number of firings.

[0033] Two samples of 20 such parts, loaded with zirconium potassium perchlorate ("ZPP") were pressed at 12,000 psi and 6,000 psi, respectively, and were tested using the statistical methods of the Sensit test. A capacitive discharge fireset was used, with a 120 microfarad capacitor, and a 1.5

ohm series resistance, in addition to the resistance of the devices under test. The test results show a mean firing voltage of 5.59 volts and a sigma of 0.055 volts for the parts pressed to 6,000 psi and a mean firing voltage of 5.50 volts and a sigma of 0.116 volts for the parts pressed to 12,000 psi.

COMPARATIVE EXAMPLE 2

[0034] By comparison, two twenty-unit samples of parts manufactured with the silicon bridge of U.S. Pat. No. 4,708,060 were assembled with the same ZPP pressed to the same pressures. The bridge areas and volumes were identical for both the silicon bridge and the titanium bridge. The data for the silicon bridge parts showed a mean firing voltage of 6.07 volts and a sigma of 0.124 volts for the parts pressed to 12,000 psi and a mean firing voltage of 6.5 volts and a sigma of 0.246 volts for the parts pressed to 6,000 psi. The results are shown in table form below.

Bridge Type/ Consolidation Pressure	Titanium Bridge Embodiment (Example 1)	Comparative Silicon Bridge (Example 2)
6,000 psi	Mean = 5.59 V Sigma = 0.055 V	Mean = 6.50 V Sigma = 0.246 V
12,000 psi	Mean = 5.50 V Sigma = 0.116 V	Mean = 6.07 V Sigma = 0.124 V

[0035] A comparison of the data of Examples 1 and 2 shows that the igniters of the present invention required less input energy and a lower voltage to attain initiation than did the identically sized comparative igniters of U.S. Pat. No. 4,708,060. These results support the belief that the exothermic reaction of the titanium layer supplements the electrical energy input into the system with the energy of the exothermic reaction of the titanium layer, to more efficiently attain initiation of the energetic material charge. The advantages enjoyed by the embodiment of the present invention over the comparative examples of the prior art are especially pronounced in the samples prepared with the lower consolidation pressure, where ignition reliability is lower than for the examples prepared with higher consolidation pressure.

[0036] While the invention has been described with reference to specific preferred embodiments thereof, it will be appreciated that, upon a reading and understanding of the foregoing, numerous alterations to those embodiments will

occur to those skilled in the art, and it is intended to include all such variations within the scope of the appended claims.

What is claimed is:

1. A semiconductor bridge igniter comprising:
a substrate;

an electrical bridge structure disposed on the substrate, the bridge structure comprising a bridge section and pad sections, the bridge section extending between and connecting the pad sections, the pad sections each comprising a layer of semiconductor material on the substrate and a layer of titanium disposed on the semiconductor material, and the bridge section consisting of a layer of semiconductor material and a layer of titanium disposed on the semi-conductor material; and
a pair of electrically conductive lands each overlying a respective one of the pad sections and being spaced apart from each other to leave the bridge section exposed.

2. The igniter of claim 1 wherein the igniter has a lower input energy requirement for initiation than an identically sized semiconductor bridge igniter layer that comprises a bridge section that includes a layer of tungsten.

3. A semiconductor bridge igniter comprising:
a substrate;

an electrical bridge structure disposed on the substrate, the bridge structure comprising a bridge section and pad sections, the bridge section extending between and connecting the pad sections, the pad sections and bridge section each comprising a layer of semiconductor material on the substrate and a layer of metal disposed on the semiconductor material, the layer of metal consisting of titanium and the bridge section being free of a layer of tungsten; and

a pair of electrically conductive lands each overlying a respective one of the pad sections and being spaced apart from each other to leave the bridge section exposed.

4. The igniter of claim 1 wherein the pad sections each consist of a layer of semi-conductor material.

5. The semiconductor bridge igniter of any one of claims 1, 2, 3 or 4 further comprising a pair of electrical leads, one connected to a respective one of the electrically conductive lands.

* * * * *