

(19) World Intellectual Property
Organization
International Bureau



(43) International Publication Date
2 December 2004 (02.12.2004)

PCT

(10) International Publication Number
WO 2004/103223 A1

- (51) International Patent Classification⁷: A61F 2/24 GOODIN, Mark, S.; 34032 Summerset Drive, Solon, OH 44134 (US).
- (21) International Application Number: PCT/US2004/015770 (74) Agent: WESORICK, Richard S; Tarolli, Sundheim, Covell & Tummino L.L.P., 526 Superior Avenue, Suite 1111, Cleveland, Ohio 44114 (US).
- (22) International Filing Date: 20 May 2004 (20.05.2004)
- (25) Filing Language: English (81) Designated States (unless otherwise indicated, for every kind of national protection available): AE, AG, AL, AM, AT, AU, AZ, BA, BB, BG, BR, BW, BY, BZ, CA, CH, CN, CO, CR, CU, CZ, DE, DK, DM, DZ, EC, EE, EG, ES, FI, GB, GD, GE, GH, GM, HR, HU, ID, IL, IN, IS, JP, KE, KG, KP, KR, KZ, LC, LK, LR, LS, LT, LU, LV, MA, MD, MG, MK, MN, MW, MX, MZ, NA, NI, NO, NZ, OM, PG, PH, PL, PT, RO, RU, SC, SD, SE, SG, SK, SL, SY, TJ, TM, TN, TR, TT, TZ, UA, UG, US, UZ, VC, VN, YU, ZA, ZM, ZW.
- (26) Publication Language: English
- (30) Priority Data:
60/472,030 20 May 2003 (20.05.2003) US
60/548,416 26 February 2004 (26.02.2004) US
- (71) Applicant: THE CLEVELAND CLINIC FOUNDATION [US/US]; 9500 Euclid Avenue, Cleveland, OH 44195 (US).
- (72) Inventors: NAVIA, José, Luis; 2707 Cranlyn Road, Shaker Heights OH 44122 (US). NAVIA, José, Antonio; 1308 Suipacha Apt.4B, Buenos Aires 1011 (AR).
- (84) Designated States (unless otherwise indicated, for every kind of regional protection available): ARIPO (BW, GH,

[Continued on next page]

(54) Title: APPARATUS AND METHODS FOR REPAIR OF A CARDIAC VALVE

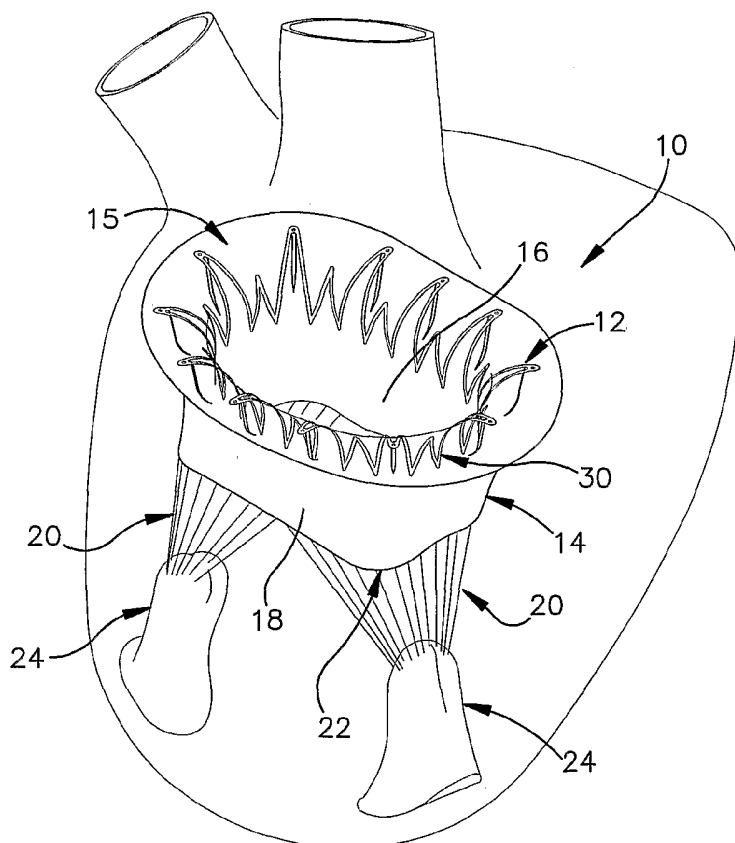

(57) Abstract: An annuloplasty ring for repairing a cardiac valve includes an expandable support member having oppositely disposed proximal and distal end portions and a main body portion between the end portions. The proximal end portion of the support member includes a plurality of wing members that extend from the main body portion. Each of the wing members includes at least one hook member for embedding into a cardiac wall and the valve annulus to secure the annuloplasty ring in the valve annulus. The annuloplasty ring may be expanded into full contact engagement with the annulus of the cardiac valve by an inflatable balloon. Methods for repairing a cardiac valve using the annuloplasty ring are also provided.

WO 2004/103223 A1



GM, KE, LS, MW, MZ, NA, SD, SL, SZ, TZ, UG, ZM, ZW), Eurasian (AM, AZ, BY, KG, KZ, MD, RU, TJ, TM), European (AT, BE, BG, CH, CY, CZ, DE, DK, EE, ES, FI, FR, GB, GR, HU, IE, IT, LU, MC, NL, PL, PT, RO, SE, SI, SK, TR), OAPI (BF, BJ, CF, CG, CI, CM, GA, GN, GQ, GW, ML, MR, NE, SN, TD, TG).

— *before the expiration of the time limit for amending the claims and to be republished in the event of receipt of amendments*

Published:

— *with international search report*

For two-letter codes and other abbreviations, refer to the "Guidance Notes on Codes and Abbreviations" appearing at the beginning of each regular issue of the PCT Gazette.

APPARATUS AND METHODS FOR REPAIR OF A CARDIAC VALVE

Related Applications

This application claims priority from U.S. provisional patent application Serial No. 60/472,030, filed on May 20, 2003, and U.S. provisional patent application Serial No. 60/547,416, filed on February 26, 2004. The subject matter of the above-listed provisional patent applications is incorporated herein by reference.

Field of the Invention

The present invention relates to an apparatus and methods for repair of a cardiac valve, and is particularly directed to an apparatus and methods that include an annuloplasty ring for the correction of mitral valve and tricuspid valve disorders.

Background of the Invention

There are two atrio-ventricular valves in the heart; one on the left side of the heart and one on the right side of the heart. The left side atrio-ventricular valve is the mitral valve and the right side atrio-ventricular valve is the tricuspid valve. Both of these valves are subject to damage

that requires that the valve be repaired or replaced. Experience has shown that damaged valves can be surgically repaired, and that the long term results obtained from valve repair can be better than replacement of the valve.

5 The mitral and tricuspid valves differ significantly in anatomy. While the annulus of the mitral valve is generally D-shaped, the annulus of the tricuspid valve is more circular. The effects of the valvular dysfunction vary between the mitral valve and the tricuspid valve. Mitral valve regurgitation has more severe physiological consequences to the patient than does
10 tricuspid valve regurgitation, a small amount of which is tolerable. In patients with valvular insufficiency, it is increasingly common surgical practice to retain the natural valves and to attempt to correct the defect. Many of these defects are associated with dilation of the valve annulus. This dilatation not only prevents competence of the valve, but also results
15 in distortion of the normal shape of the valve orifice. Remodeling the valve annulus is therefore central to most reconstructive procedures for both the mitral and tricuspid valves.

 Mitral or tricuspid valve annuloplasty is a restoration of the valve annulus, which effects full closure of the valve's leaflets by reestablishing
20 the size and the shape of the normal mitral or tricuspid valve annulus. Surgical procedures such as annuloplasty more commonly incorporate the use of a prosthetic ring, where the ring is implanted over or within the mitral or tricuspid valve annulus.

In mitral valve insufficiency, the valve leaflets do not fully close and a certain amount of blood leaks back into the left atrium when the left ventricle contracts. As a result, the heart has to work harder by pumping not only the regular volume of the blood, but also the extra volume of blood that regurgitated back into the left atrium. The added workload creates an undue strain on the left ventricle. This strain can eventually wear out of the heart and result in morbidity when the conditions are prolonged and severe enough. Consequently, proper function of the mitral valve is critical to the pumping efficiency of the heart.

Many surgical procedures have been described to correct pathology of the valve leaflets, chordal tendineae, and papillary muscles. In mitral valve repair, it is desirable to preserve the normal distance between the two fibrous trigones. The trigones more or less straddle the anterior leaflet portion of the mitral annulus. A significant surgical reduction of the inter-trigonal distance could cause left ventricular outflow tract obstruction. Thus, it is desirable to maintain the natural inter-trigonal distance after mitral valve surgery. Consequently, when a mitral valve is repaired, the result is generally a reduction in size of the posterior segment of the mitral valve annulus.

In a mitral valve repair, it is necessary to either diminish or constrict the involved segment of the mitral annulus so that the leaflets may coapt correctly when closing or, alternatively, to stabilize the annulus to prevent the possibility of dilatation from occurring. The latter is frequently achieved by implantation of a prosthetic ring in the supra-annular position. The

purpose of the ring is to restrict and/or support the annulus to correct and/or prevent valvular insufficiency. However, it is important not to over-restrict the annulus or unacceptable valve stenosis could result.

As described above, in mitral valve repair, constriction of the mitral
5 annulus should take place only in the area of the posterior portion of the native valve annulus. Shortening of the posterior portion of the mitral valve annulus may be accomplished by implanting an inexpandable rigid ring. With this approach, the surgeon must accurately choose the size of the ring that would prevent insufficiency, yet will not cause significant valve
10 stenosis. A second approach uses a contractible ring that may be plicated during implantation. This approach has a disadvantage that a surgeon must accurately gauge not only the ring size to use, but also how to space the implanting sutures in the ring and the native annulus so that, when implanted, insufficiency is minimized. A third approach involves
15 semi-expandable rings that may be contracted only in appropriate segments of the native annulus (but not in the anterior portion). The natural inter-trigonal distance should be maintained and the anterior leaflet should not be diminished in this circumstance.

In tricuspid valve repair, constriction of the annulus usually takes
20 place in the posterior leaflet segment and in a small portion of the adjacent anterior leaflet. The septal leaflet segment is not usually required to be shortened.

Mitral and tricuspid valve disease is traditionally treated by surgical repair with an annuloplasty ring or surgical or replacement with a valve

prosthesis. However, surgical valve replacement or repair is often an exacting operation that is done through a surgical technique where the thoracic cavity is opened. The operation requires use of a heart-lung machine for external circulation of the blood as the heart is stopped and opened during the surgical intervention and the artificial cardiac valves and/or annuloplasty rings are sewed in under direct vision. This operation exposes the patient to many risks especially in the elderly population. A percutaneous procedure that can be performed under local anesthesia in the cardiac catheterization lab, rather than in cardiac surgery, could therefore offer tremendous benefits for these patients, many of whom have no options today. A minimally invasive surgical technique and percutaneous approach for delivering a prosthetic ring for mitral or tricuspid valve repair could be one of the most prominent tools in order to provide opportunities to treat patients with severe valvular insufficiency and/or end stage heart failure.

Summary of the Invention

The present invention is an annuloplasty ring for repairing a cardiac valve. The annuloplasty ring comprises an expandable support member having oppositely disposed proximal and distal end portions and a main body portion between the end portions. The proximal end portion of the support member comprises a plurality of wing members that extend from the main body portion. Each of the wing members includes at least one hook member for embedding into a cardiac wall and into the annulus of the cardiac valve to secure the annuloplasty ring in the annulus.

In accordance with one aspect of the invention, the hook members, when embedded into the cardiac wall and the valve annulus, extend distally from the wing members.

5 In accordance with another aspect of the invention, the main body portion has a concave cross-sectional shape for conforming to the convex shape of the valve annulus.

In accordance with another aspect of the invention, each of the wing members has a concave cross-sectional shape for conforming to the convex shape of the valve annulus.

10 In accordance with another aspect of the invention, the main body portion and the wing members are resiliently bendable from the concave cross-sectional shapes into flatter cross-sectional shapes for delivery and placement of the annuloplasty ring.

15 In accordance with another aspect of the invention, the apparatus further comprises a constraining wire for temporarily holding the wing members in the flatter cross-sectional shape. The hook members extend generally radially when the wing members are being held in the flatter cross-sectional shape by the constraining wire.

20 In accordance with another aspect of the invention, the hook members are resiliently bendable to extend proximally inside a delivery capsule or sleeve during delivery of the annuloplasty ring into the valve annulus.

In accordance with another aspect of the invention, the annuloplasty ring further comprises a layer of biocompatible material covering at least a

portion of the distal end portion and the main body portion of the support member.

In accordance with another aspect of the invention, the support member is made from a shape memory material that is responsive to changes in temperature above and below a predetermined temperature transition range. The support member has a first configuration when the temperature is below the predetermined temperature transition range and a second configuration when heated above the predetermined temperature transition range.

In accordance with another aspect of the invention, the annuloplasty ring is insertable into the annulus of the cardiac valve in the first configuration and is thereafter heatable above the predetermined temperature transition range to change the support member into the second configuration, wherein movement of the support member into the second configuration causes a reduction in size of the opening defined by the valve annulus.

In accordance with another aspect of the invention, the support member is expandable by an inflatable balloon so that the annuloplasty ring engages the annulus of the cardiac valve.

The present invention further includes an apparatus for repairing a cardiac valve. The annuloplasty ring comprises an expandable support member having oppositely disposed proximal and distal end portions and a main body portion between the two end portions. The proximal end of the support member includes a plurality of wing members that extend from the

main body portion. Each of the wing members includes at least one hook member for embedding into a cardiac wall and the annulus of the cardiac valve to secure the annuloplasty ring in the annulus. An inflatable balloon expands the support member so that the annuloplasty ring engages the annulus of the cardiac valve with full contact.

5 In accordance with one aspect of the invention, the balloon has an hourglass shape defined by first and second bulb sections connected by a center section having a smaller diameter than the bulb sections. The annuloplasty ring is positioned about the center section.

10 The present invention further provides a method for repairing a cardiac valve. According to the inventive method, an annuloplasty ring having an expandable support member is provided. The annuloplasty ring is placed around an inflatable balloon in a secured manner. The balloon and annuloplasty ring are then inserted into an atrial chamber and

15 advanced until the annuloplasty ring is positioned within the annulus of the cardiac valve to be repaired. Next, the support member is extended with the balloon so that the annuloplasty ring engages the annulus of the cardiac valve. The annuloplasty ring is secured in the valve annulus. The balloon is then collapsed and removed from the atrial chamber.

20 In accordance with another aspect of the inventive method, the balloon has an hourglass shape defined by first and second bulb sections connected by a center section having a smaller diameter than the bulb sections. The annuloplasty ring is positioned about the center section.

In accordance with another aspect of the inventive method, a first bulb section of the balloon is positioned within the leaflets of the native valve so that, when the balloon is inflated, the first bulb pushes the valve leaflets back to protect the leaflets during expansion of the support member.

In accordance with another aspect of the inventive method, the support member has oppositely disposed proximal and distal end portions connected by a main body portion that has a concave cross-sectional shape. The step of expanding the support member with the balloon so that the annuloplasty ring engages the annulus of the cardiac valve includes conforming the concave main body portion to the convex shape of the valve annulus to help locate and secure the annuloplasty ring in the valve annulus.

In accordance with another aspect of the inventive method, the proximal end of the support member comprises a plurality of wing members that extend from the main body portion. Each of the wing members includes at least one resiliently bendable hook member extending from each of the wing members. The method further includes the step of embedding the hook members into a cardiac wall to further secure the annuloplasty ring in the valve annulus.

In accordance with another aspect of the inventive method, each of the wing members has a concave cross-sectional shape for conforming to the convex shape of the valve annulus. The method further comprises the step of pulling the wing members into a flatter cross-sectional shape with a

-10-

constraining wire for placement of the annuloplasty ring. The hook members extend generally radially when the wing members are being held by the constraining wire.

In accordance with another aspect of the inventive method, the hook members are bent to extend proximally inside a delivery capsule or sleeve for delivery of the annuloplasty ring.

In accordance with another aspect of the inventive method, the constraining wire is released after the step of expanding the support member with the balloon so that the wing members bend radially outward to position the hook members above the valve annulus for embedding into the valve annulus.

In accordance with another aspect of the inventive method, the step of releasing the constraining wire causes the hook members to embed into the cardiac wall in the distal direction.

In accordance with another aspect of the inventive method, the support member is made from a shape memory material that is responsive to changes in temperature above and below a predetermined temperature transition range. The support member has a first configuration when the temperature is below the predetermined temperature transition range and a second configuration when heated above the predetermined temperature transition range. The method further includes cooling the support member prior to inserting the annuloplasty ring into the annulus of the cardiac valve in order to place the support in the first configuration.

In accordance with another aspect of the inventive method, the support member is heated above the predetermined temperature transition range so that the support member changes into the second configuration.

5 In accordance with another aspect of the inventive method, heating the support member is done following the expansion of the support member with the balloon. The heating process contracts the annuloplasty ring and thereby restricts the valve annulus to support the valve annulus and correct valvular insufficiency.

10 In accordance with another aspect of the inventive method, the step of heating is accomplished by exposing the support member to body temperature.

In accordance with another aspect of the inventive method, the balloon and annuloplasty ring are inserted into the atrial chamber percutaneously via an intravascular catheter.

15 **Brief Description of the Drawings**

The foregoing and other features of the present invention will become apparent to those skilled in the art to which the present invention relates upon reading the following description with reference to the accompanying drawings, in which:

20 Fig. 1 is a schematic perspective view of a heart implanted with an annuloplasty ring for repairing a cardiac valve in accordance with the present invention;

Fig. 2 is a schematic plan view of the heart and the annuloplasty ring shown in Fig. 1;

Fig. 3 is a perspective view of the annuloplasty ring of Fig. 1 illustrating the ring in a fully deployed condition;

Fig. 4 is a perspective view similar to Fig. 3 illustrating an alternative construction for the annuloplasty ring;

5 Fig. 5 is a perspective view of the annuloplasty ring of Fig. 3 with the ring being shown in a radially collapsed condition for delivery (prior to expansion by a balloon);

Fig. 6 is a side view, partly in section, of an apparatus for repairing a cardiac valve comprising the annuloplasty ring of Fig. 3, the apparatus
10 being shown at an initial stage of delivery into an atrial chamber;

Fig. 7 is a side view similar to Fig. 6 illustrating the apparatus at a subsequent stage of delivery;

Fig. 8 is a side view similar to Fig. 7 illustrating the apparatus at another subsequent stage of delivery;

15 Fig. 9 is a side view similar to Fig. 8 illustrating the annuloplasty ring being deployed in the valve annulus by expansion of a balloon;

Fig. 10 is an enlarged view of a portion of Fig. 9;

Fig. 11 is a side view similar to Fig. 9 illustrating a further step in the deployment of the annuloplasty ring;

20 Fig. 12 is an enlarged view of a portion of Fig. 11;

Fig. 13 is a side view similar to Fig. 11 illustrating the annuloplasty ring implanted in the valve annulus with the balloon deflated; and

Fig. 14 is a side view similar to Fig. 13 illustrating the constricting effect that the shape memory material of the annuloplasty ring has on the valve annulus.

Detailed Description of Embodiments

5 The present invention relates to an apparatus and methods for repair of a cardiac valve. As representative of the present invention, Fig. 1 illustrates an apparatus 10 that includes an annuloplasty ring 12 for repairing a dysfunctional cardiac valve, such as a mitral valve 14. It should be understood, however, that the apparatus 10 disclosed herein could be
10 used to repair not only a mitral valve, but also other cardiac valves and, in particular, a tricuspid valve.

 The mitral valve 14 is located between the left atrium and the left ventricle and functions to prevent the backflow of blood from the left ventricle into the left atrium during contraction. As best seen in Fig. 2, the
15 mitral valve 14 has a D-shaped annulus 15 that defines the opening between the left atrium and the left ventricle. The mitral valve 14 is formed by two leaflets; namely, the anterior leaflet 16 and the posterior leaflet 18. The anterior leaflet 16 extends along the generally planar base of the D-shaped valve annulus 15 between two fibrous trigones (not shown). It is
20 desirable to maintain the distance X (Fig. 2) between the two trigones after the valve repair procedure is completed. The posterior leaflet 18 extends arcuately around the curved portion of the D-shaped annulus 15 of the mitral valve 14. Chordae tendineae 20 (Fig. 1) extend between the free

edges 22 of both leaflets 16 and 18 to the papillary muscles 24 in the left ventricle.

The annuloplasty ring 12 for repairing the dysfunctional mitral valve 14 comprises an expandable support member 30 that resembles a complete stent. The annuloplasty ring 12 described herein has an annular configuration that mimics the D-shape of the native annulus 15, but it will be understood by those skilled in the art that the annuloplasty ring could be a partial ring and thus have a C-shape, a U-shape, or another suitable configuration. The support member 30 is both flexible and resilient, and, as discussed in more detail below, is made of a shape memory material such as Nitinol. Other suitable medical grade metals or plastics having shape memory characteristics can also be used for the support member 30. The flexible and expandable properties of the support member 30 allow it to conform to the three-dimensional shape of the native valve annulus 14.

The support member 30 comprises a continuous series of W-shaped segments, although it is contemplated that other geometries could be used. The lower, as viewed in Fig. 3, tips of the W-shaped segments form a distal end portion 32 of the support member 30 and the elongated upper tips of the W-shaped segments form a proximal end portion 34 of the support member. For purposes of this disclosure, the term "proximal" means on the inflow or upstream side of the annuloplasty ring 12 and "distal" means on the outflow or downstream side of the annuloplasty ring. Thus, the distal end portion 32 of the support member 30 is the leading edge of the support member when the annuloplasty ring 12 is inserted into the body. Further,

as illustrated in Fig. 6, the letter A indicates the distal direction and the letter B indicates the proximal direction.

Referring again to Fig. 3, a main body portion 36 of the support member 30 is defined between the distal and proximal end portions 32 and 34. The main body portion 36 has a concave cross-sectional shape for conforming to the convex shape of the valve annulus 15. It is contemplated that the pattern of the support member 30 and/or the thickness of the support member in the main body portion 36 may be altered along the inter-trigonal distance X in order to maintain this distance and ensure more retraction along the posterior leaflet 18.

The proximal end portion 34 of the support member 30 comprises a plurality of wing members 40 that resemble arches and which extend integrally from the main body portion 36 generally in the proximal direction B. The wing members 40 also have a concave cross-sectional shape for conforming to the convex shape of the valve annulus 15. As is shown in Figs. 5-10, the main body portion 36 and the wing members 40 are resiliently bendable from their concave cross-sectional shapes into flatter cross-sectional shapes for delivery and placement of the annuloplasty ring 12.

Each wing member 40 of the support member 30 has a tip portion 42 (Fig. 3) that includes an aperture 44 for receiving a wire. Further, the tip portion 42 of each wing member 40 includes at least one hook member 46 for embedding into a cardiac wall to secure the annuloplasty ring 12 in the annulus 15 of the mitral valve 14. The hook

members 46 project outward from the wing members 40 and have sharp pointed ends. It is contemplated that the pointed ends of the hook members 46 could include one or more barbs (not shown), similar to the barbs used in fishing hooks, to prevent pull-out of the hook members once they are embedded in the valve annulus 15.

As mentioned above, the support member 30 is made from a shape memory material, such as Nitinol, that is responsive to changes in temperature above and below a predetermined temperature transition range of 75–95 degrees Fahrenheit, although it should be understood that other temperature transition ranges could be used. The support member 30 has a first configuration when its temperature is below the predetermined temperature transition range and a second configuration when heated above the predetermined temperature transition range. In accordance with one aspect of the invention, the annuloplasty ring 12 is inserted into the annulus 15 of the mitral valve 14 in the first configuration, which is an expanded condition, and is thereafter heated above the predetermined temperature transition range to change the support member 30 into the second configuration, which is a contracted condition that is the desired pre-shape memorized by the material.

Fig. 4 illustrates the annuloplasty ring 12 with a layer 50 of biocompatible material covering sections of the distal end portion 32 and the main body portion 36 of the support member 30. The layer 50 of biocompatible material may be a synthetic such as Dacron[®], woven velour, polyurethane, PTFE, or heparin-coated fabric. Alternatively, the layer 50

-17-

may be a biological material such as bovine or equine pericardium, a homograft, patient graft, or a cell-seeded tissue. The layer 50 can cover either the inside surface of the support member 30, the outside surface of the support member, or can be wrapped around both the inside and outside
5 surfaces. The layer 50 may be attached around the entire circumference of the support member 30 or, alternatively, may be attached in sections as shown in Fig. 4 to allow the support member to more easily expand and contract.

The apparatus 10 further comprises a releasable constraining
10 wire 52 (Fig. 5) for temporarily holding the wing members 46 in the flatter cross-sectional shape shown in Figs. 5-10 during delivery and placement of the annuloplasty ring 12. The constraining wire 52 can be made from a variety of different materials including metals, polymers, synthetics, fabrics, and biological tissues. As illustrated in Figs. 5 and 7-10, the hook
15 members 46 extend generally radially when the wing members 40 are being held in the flatter cross-sectional shape by the constraining wire 52. However, as shown in Fig. 6, the hook members 46 are resiliently bendable to extend proximally inside a delivery capsule 54 during delivery of the annuloplasty ring 12 into the valve annulus 15. It should be understood
20 that the delivery capsule 54 could have a variety of configurations, including a sleeve or sheath.

The apparatus 10 further comprises an inflatable balloon 60 (Fig. 6) for expanding the annuloplasty ring 12 into full and complete contact with the annulus 15 of the cardiac valve 14. The balloon 60 has an hourglass

shape defined by first and second bulb sections 62 and 64 connected by a center section 66. Each of these sections 62, 64 and 66 may have a D-shaped diameter (or other shaped diameter) to match the D-shaped diameter of the valve 14 and the annuloplasty ring 12. The center
5 section 66 of the balloon 60 has a smaller diameter than the bulb sections 62 and 64. The first and second bulb sections 62 and 64 and the center section 66 may be inflated together or separately. Further, the sections 62, 64 and 66 may have multiple chambers to accommodate multiple fluids (i.e., an inflation fluid and a cooling fluid).

10 To repair the mitral valve 14 with the apparatus 10 using a percutaneous (or intravascular) approach, the annuloplasty ring 12 is properly sized for the mitral valve by the surgical team using fluoroscopic and/or echocardiographic data. The annuloplasty ring 12 may be cooled using a cryogenic source or other suitable means to place the support
15 member 30 in its first configuration. The annuloplasty ring 12 is then positioned about the center section 66 of the balloon 60. It is contemplated that the annuloplasty ring 12 could alternatively, or as a supplement, be cooled by infusing the balloon with a cooling fluid or other medium. The constraining wire 52 is pulled tight, which results in the wing members 40
20 bending radially inward from their convex cross-sectional shape to the flatter cross-sectional shape of Fig. 6. The delivery capsule 54 is then placed over the balloon 60 and the annuloplasty ring 12. Inside the capsule 54, the hook members 46 are bent upward in the proximal

-19-

direction B. The apparatus 10 is then loaded into an 16 to 22 French catheter (not shown) in a known manner.

The apparatus 10 is introduced into the right jugular vein using a known percutaneous technique called the Seldinger technique and is
5 advanced through the superior vena cava to approach the right atrium. The catheter is then passed through the interatrial septum to reach the left atrium. Inside the left atrium, the apparatus 10 is positioned just above the mitral valve 14 as is shown in Fig. 6.

Next, the delivery capsule 54 is opened, which exposes the
10 balloon 60 and the annuloplasty ring 12 and also allows the hook members 46 to spring back to the position illustrated in Fig. 7. The balloon 60 is then advanced distally into the annulus 15 of the mitral valve 14 until the center section 66 of the balloon 60 (where the annuloplasty ring 12 is positioned) is at the level of the annulus, as shown
15 in Fig. 8.

Next, the balloon 60 is inflated to radially expand the annuloplasty ring 12 into full and complete engagement with the valve annulus 15. When the balloon 60 is inflating, the first bulb 62 pushes the valve leaflets 16 and 18 back to protect the leaflets during expansion of the
20 support member 30. The constraining wire 52 is loosed slightly to compensate for the growing diameter of the expanding balloon 60, but the wire is not completely released. This keeps the wing members 40 held against the balloon 60 for the time being, and also keeps the hook members 46 pointed above the level of the valve annulus 15. The

-20-

balloon 60 is inflated to the point where the ring 12 is over-expanded in order to ensure full and complete engagement with diseased/dilated annulus 15. As is illustrated in Figs. 9 and 10, this full annular engagement of the distal end portion 32 of the support member 30 ensures that the
5 annuloplasty ring 12 seats against the inside of the valve annulus 15 and forms a point of fixation for the annuloplasty ring.

The constraining wire 52 is then released, which allows the main body portion 36 and the wing members 40 of the support member 30 to spring back to their convex shape as shown in Fig. 11. As the wing
10 members 40 bend radially outward, the hook members 46 swing downward in the distal direction A and embed into the cardiac wall 70 and the valve annulus 15. The embedded hook members 46 thus extend distally from the wing members 40 into the cardiac wall 70 to provide the primary point of fixation for the annuloplasty ring 12. As shown in Fig. 12, the convex
15 shape of the support member 30 conforms to the concave shape of the valve annulus 15 and the annuloplasty ring 12 becomes clamped in the annulus between the distal end portion 32 of the support member and the distally extending hook members 46.

As shown in Figs. 13 and 14, the balloon 60 is then deflated and
20 moved out of the valve annulus 15. Fig. 14 also illustrates the final step in the process whereby exposure of the support member 30 to body temperature over time raises the temperature above the transition range. It is contemplated that the temperature of the support member 30 could also be elevated by infusing the balloon 60 with warm saline. Raising the

-21-

temperature of the support member 30 above the transition range causes the annuloplasty ring 12 to contract, which reduces the size of the opening of the valve annulus 15 to a predetermined size and shape defined by the second configuration for the support member 30. It should be noted that

5 the constriction of the annuloplasty ring 12 to the predetermined size reduces the posterior portion of the annulus 15 but maintains the desired inter-trigonal distance X as another mechanism of fixation.

The constriction of the annuloplasty ring 12 due to the shape memory material of the support member 30 thus reestablishes the size of

10 the valve annulus 15 to normal. The flexibility of the support member 30 allows the annuloplasty ring 12 to follow the native shape and contour of the valve annulus, yet provide structural support for the annulus which improves the coaptation of the native leaflets 16 and 18 and restores normal valve function.

15 Before the balloon 60 and the constraining wire 52 are completely withdrawn, the competency of the remodeled valve 14 can be tested by echocardiogram. If necessary, the annuloplasty ring 12 can be re-positioned by tightening the constraining wire 52 to pull the wing members 40 and the hook members 46 upward and out of the cardiac

20 wall 70 and the annulus 15, and then re-inflating the balloon 60 to re-acquire the annuloplasty ring. If the echocardiogram shows the valve repair to be successful, then the constraining wire 52 is pulled out of the apertures 44 in the hook members 46 and the rest of the apparatus 10, including the balloon 60, is removed from the atrial chamber.

The present invention thus allows for the annuloplasty ring 12 to be delivered in a cardiac catheterization laboratory with a percutaneous approach under local anesthesia using fluoroscopic as well as echocardiographic guidance, thereby avoiding general anesthesia and highly invasive open heart surgery techniques. This approach offers tremendous advantages for high risk patients with severe valvular regurgitation. It should be understood, however, that the present invention contemplates various other approaches, including standard open heart surgeries as well as minimally invasive surgical techniques. Because the present invention omits stitching of the annuloplasty ring 12 in the valve annulus 15, surgical time is reduced regardless of whether an open or percutaneous approach is used.

The technique for implanting the annuloplasty ring 12 in the tricuspid valve follows the same steps described above for the mitral valve 14, except that all of the delivery and implantation steps for a tricuspid annuloplasty ring take place inside the right atrium and on a dilated native tricuspid valve. The annuloplasty ring 12 disclosed herein is capable of achieving an adjustable restriction in a deeper portion of the posterior leaflet segment and in a small portion of the adjacent anterior leaflet. The septal leaflet segment is not usually required to be shortened, so the tricuspid valve annuloplasty ring improves leaflet coaptation and valve function by restriction of the anterior and posterior portions of the native valve tricuspid annulus.

From the above description of the invention, those skilled in the art will perceive improvements, changes and modifications. For example, it is contemplated that, in addition to the balloon-based apparatus disclosed herein, a mechanical-based apparatus could be used to deliver and deploy
5 the annuloplasty ring described herein. Such improvements, changes and modifications within the skill of the art are intended to be covered by the appended claims.

Having described the invention, we claim:

1. An annuloplasty ring for repairing a cardiac valve, said annuloplasty ring comprising:
 - an expandable support member having oppositely disposed proximal and distal end portions and a main body portion between said end portions, said proximal end portion of said support member comprising a plurality of wing members that extend from said main body portion; and
 - each of said wing members including at least one hook member for embedding into a cardiac wall and the annulus of the cardiac valve to secure said annuloplasty ring in the annulus.
2. The annuloplasty ring of claim 1 wherein said hook members, when embedded into the cardiac wall and the valve annulus, extend distally from said wing members.
3. The annuloplasty ring of claim 1 wherein said main body portion has a concave cross-sectional shape for conforming to the convex shape of the valve annulus.
4. The annuloplasty ring of claim 3 wherein each of said wing members has a concave cross-sectional shape for conforming to the convex shape of the valve annulus.

5. The annuloplasty ring of claim 4 wherein said main body portion and said wing members are resiliently bendable from said concave cross-sectional shapes into flatter cross-sectional shapes for delivery and placement of said annuloplasty ring.

6. The annuloplasty ring of claim 5 further comprising a constraining wire for temporarily holding said wing members in said flatter cross-sectional shape, said hook members extending generally radially when said wing members are being held in said flatter cross-sectional shape by said constraining wire.

7. The annuloplasty ring of claim 6 wherein said hook members are resiliently bendable to extend proximally inside a delivery capsule during delivery of said annuloplasty ring into the valve annulus.

8. The annuloplasty ring of claim 1 further comprising a layer of biocompatible material covering at least a portion of said distal end portion and said main body portion of said support member.

9. The annuloplasty ring of claim 1 wherein said support member is made from a shape memory material that is responsive to changes in temperature above and below a predetermined temperature transition range, said support member having a first configuration when the temperature is below said predetermined temperature transition range, said

support member having a second configuration when heated above said predetermined temperature transition range.

10. The annuloplasty ring of claim 9 wherein said support member is insertable into the annulus of the cardiac valve in said first configuration and is thereafter heatable above said predetermined temperature transition range to change said support member into said second configuration, wherein movement of said support member into said second configuration causes a reduction in size of the opening defined by the valve annulus.

11. The annuloplasty ring of claim 1 wherein said support member is expandable by an inflatable balloon so that said annuloplasty ring engages the annulus of the cardiac valve.

12. An apparatus for repairing a cardiac valve, said apparatus comprising:

an annuloplasty ring including an expandable support member having oppositely disposed proximal and distal end portions and a main body portion between said end portions, said proximal end portion of said support member comprising a plurality of wing members that extend from said main body portion;

-27-

each of said wing members including at least one hook member for embedding into a cardiac wall and the valve annulus to secure said annuloplasty ring in the annulus of the cardiac valve; and

an inflatable balloon for expanding said support member so that said annuloplasty ring engages the annulus of the cardiac valve.

13. The annuloplasty ring of claim 12 wherein said hook members, when embedded into the cardiac wall and the valve annulus, extend distally from said wing members.

14. The apparatus of claim 12 wherein said main body portion has a concave cross-sectional shape for conforming to the convex shape of the valve annulus.

15. The apparatus of claim 14 wherein each of said wing members has a concave cross-sectional shape for conforming to the convex shape of the valve annulus.

16. The apparatus of claim 15 where said main body portion and said wing members are resiliently bendable from said concave cross-sectional shapes into flatter cross-sectional shapes for delivery and placement of said annuloplasty ring.

17. The apparatus of claim 16 further comprising a constraining wire for temporarily holding said wing members in said flatter cross-sectional shape, said hook members extending generally radially when said wing members are being held in said flatter cross-sectional shape by said constraining wire.

18. The apparatus of claim 17 wherein said hook members are resiliently bendable to extend proximally inside a delivery capsule during delivery of said annuloplasty ring into the valve annulus.

19. The apparatus of claim 12 further comprising a layer of biocompatible material covering at least a portion of said distal end portion and said main body portion of said support member.

20. The apparatus of claim 12 wherein said support member is made from a shape memory material that is responsive to changes in temperature above and below a predetermined temperature transition range, said support member having a first configuration when the temperature is below said predetermined temperature transition range, said support member having a second configuration when heated above said predetermined temperature transition range.

21. The apparatus of claim 20 wherein said support member is insertable into the annulus of the cardiac valve in said first configuration and is thereafter heatable above said predetermined temperature transition range to change said support member into said second configuration, wherein movement of said support member into said second configuration causes a reduction in size of the opening defined by the valve annulus.

22. The apparatus of claim 12 wherein said balloon has an hourglass shape defined by first and second bulb sections connected by a center section having a smaller diameter than said bulb sections, said annuloplasty ring being positioned about said center section.

23. A method for repairing a cardiac valve, said method comprising the steps of:

providing an annuloplasty ring having an expandable support member;

placing the annuloplasty ring around an inflatable balloon in a secured manner;

inserting the balloon and annuloplasty ring into an atrial chamber;

advancing the balloon until the annuloplasty ring is positioned within the annulus of the cardiac valve to be repaired;

-30-

expanding the support member with the balloon so that the annuloplasty ring engages the annulus of the cardiac valve to secure the annuloplasty ring in the annulus;

securing the annuloplasty ring in the valve annulus;

collapsing the balloon; and

removing the balloon from the atrial chamber.

24. The method of claim 23 wherein the balloon has an hourglass shape defined by first and second bulb sections connected by a center section having a smaller diameter than the bulb sections, said step of placing the annuloplasty ring around the balloon further comprising the step of positioning the annuloplasty ring about the center section.

25. The method of claim 24 wherein said step of advancing the balloon until the annuloplasty ring is positioned within the valve annulus further includes the step of positioning the first bulb section within the leaflets of the native valve so that when the balloon is inflated the first bulb pushes the valve leaflets back to protect the leaflets during expansion of the support member.

26. The method of claim 23 wherein said support member has oppositely disposed proximal and distal end portions connected by a main body portion that has a concave cross-sectional shape, said step of expanding the support member with the balloon so that the annuloplasty

ring engages the annulus of the cardiac valve includes the step of conforming the concave main body portion to the convex shape of the valve annulus to help locate and secure the annuloplasty ring in the valve annulus.

27. The method of claim 26 wherein the proximal end portion of the support member comprises a plurality of wing members that extend from the main body portion, each of the wing members including at least one resiliently bendable hook member extending from each of the wing members, said method further including the step of embedding the hook members into a cardiac wall and the valve annulus to further secure the annuloplasty ring in the valve annulus.

28. The method of claim 27 wherein each of the wing members has a concave cross-sectional shape for conforming to the convex shape of the valve annulus, said method further comprising the step of pulling the wing members into a flatter cross-sectional shape with a constraining wire for placement of the annuloplasty ring, the hook members extending generally radially when the wing members are being held by the constraining wire.

29. The method of claim 28 further comprising the step of bending the hook members to extend proximally inside a delivery capsule for delivery of the annuloplasty ring.

30. The method of claim 28 further comprising the step of releasing the constraining wire after said step of expanding the support member with the balloon so that the wing members bend radially outward to position the hook members above the valve annulus for embedding into the cardiac wall and the valve annulus.

31. The method of claim 30 wherein said step of releasing the constraining wire causes the hook members to embed into the cardiac wall in the distal direction.

32. The method of claim 23 wherein the support member is made from a shape memory material that is responsive to changes in temperature above and below a predetermined temperature transition range, the support member having a first configuration when the temperature is below the predetermined temperature transition range and a second configuration when heated above the predetermined temperature transition range, said method further including the step of cooling the support member prior to inserting the annuloplasty ring into the annulus of the cardiac valve in order to place the support in the first configuration.

33. The method of claim 32 further comprising the step of heating the support member above the predetermined temperature transition range so that the support member changes into the second configuration.

34. The method of claim 33 wherein said step of heating the support member is done following said step of expanding the support member with the balloon, said step of heating the support member contracts the annuloplasty ring and thereby restricts the valve annulus to support the annulus and correct valvular insufficiency.

35. The method of claim 33 wherein said step of heating is accomplished by exposing the support member to body temperature.

36. The method of claim 23 wherein said step of inserting the balloon and annuloplasty ring into the atrial chamber is done percutaneously via an intravascular catheter.

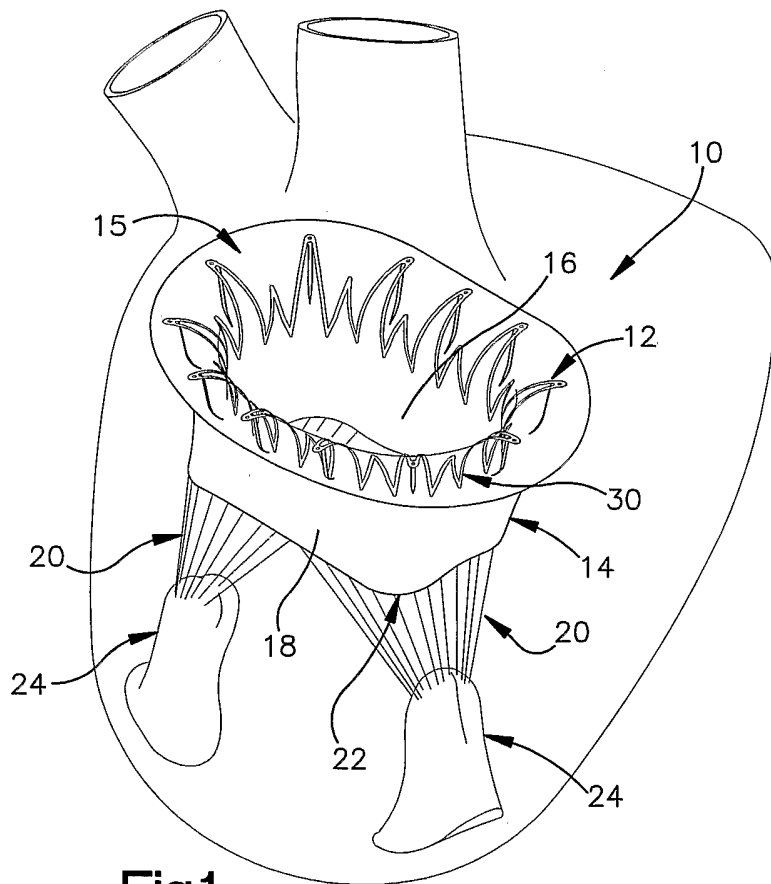

Fig.1

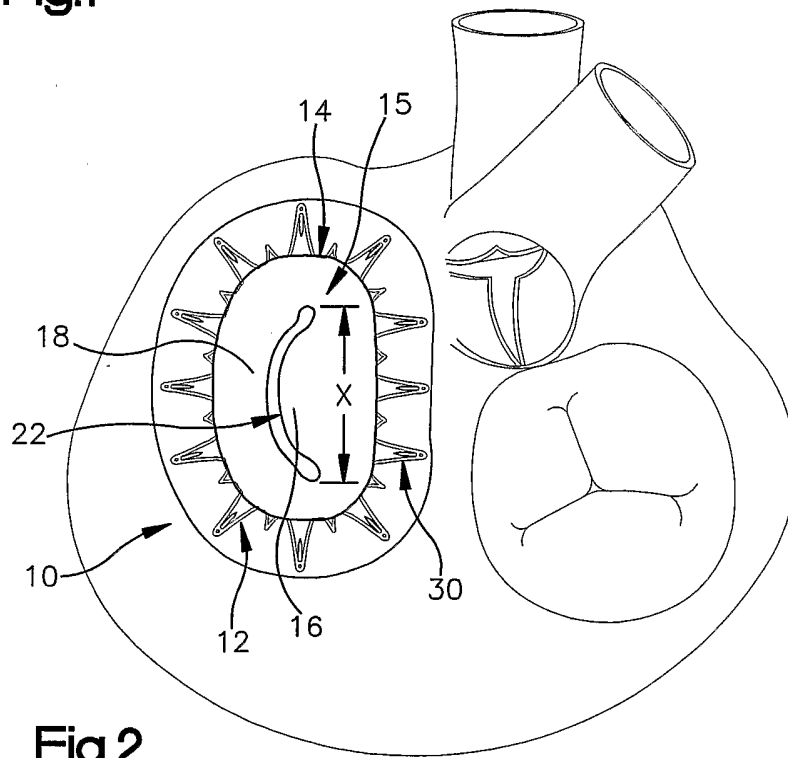

Fig.2

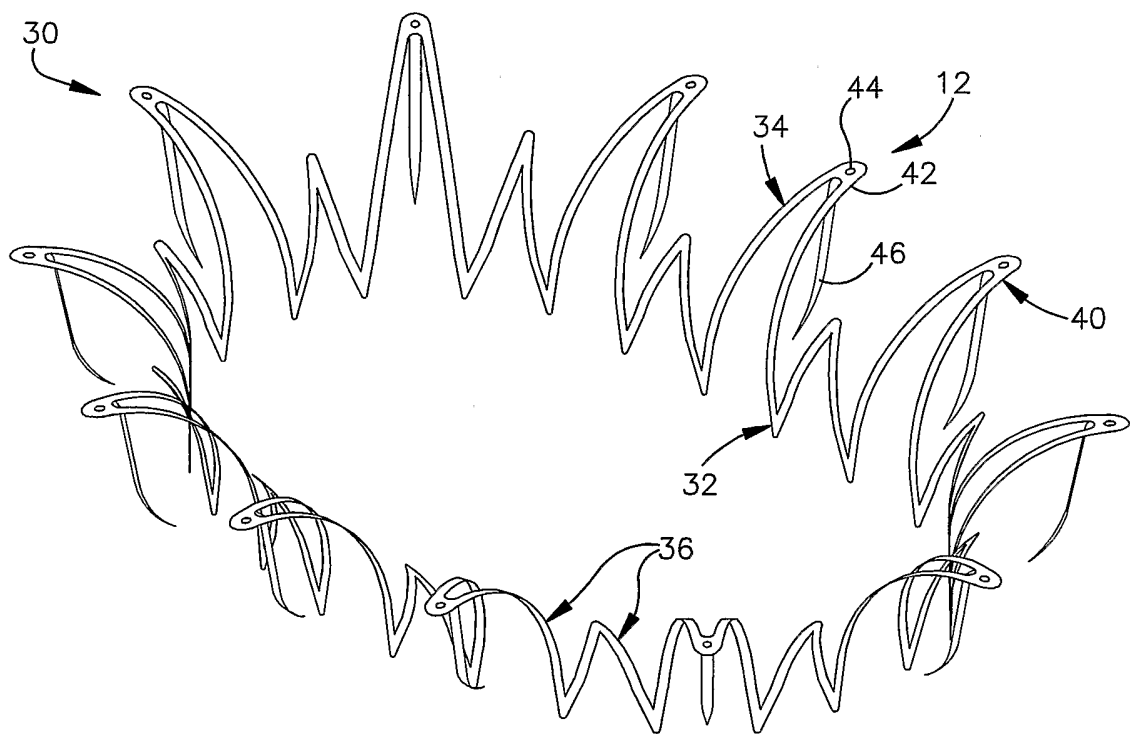

Fig.3

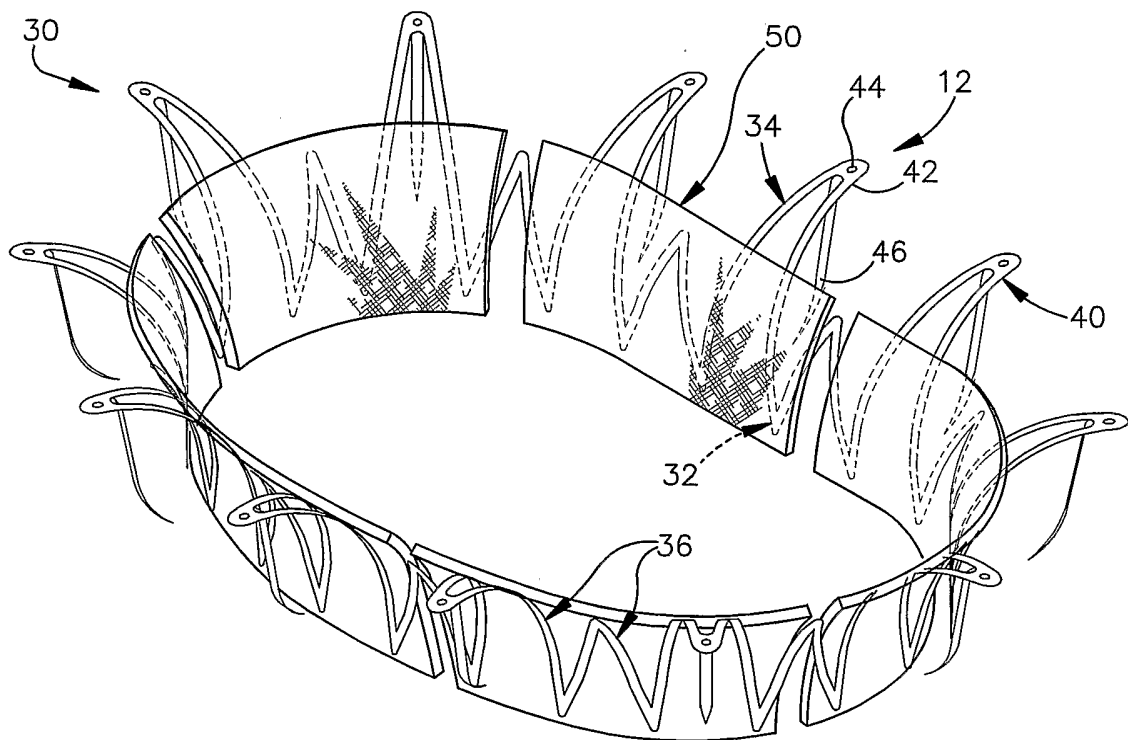

Fig.4

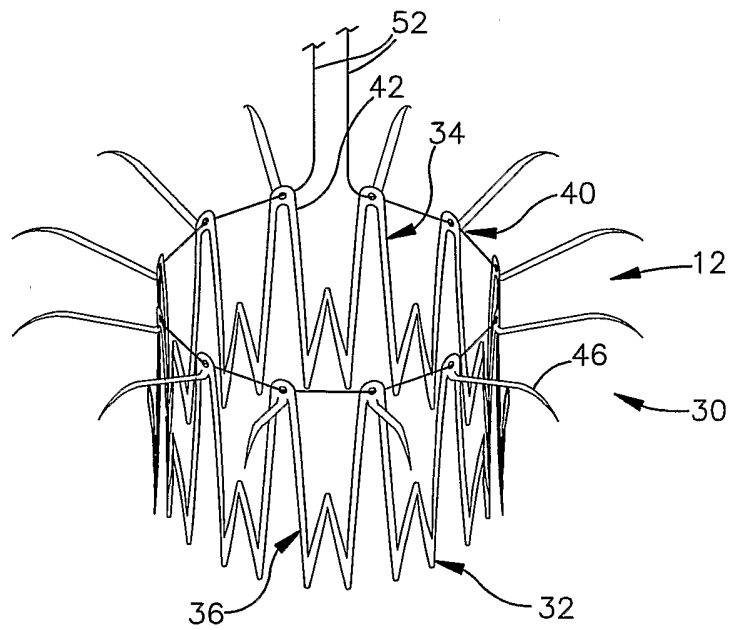

Fig.5

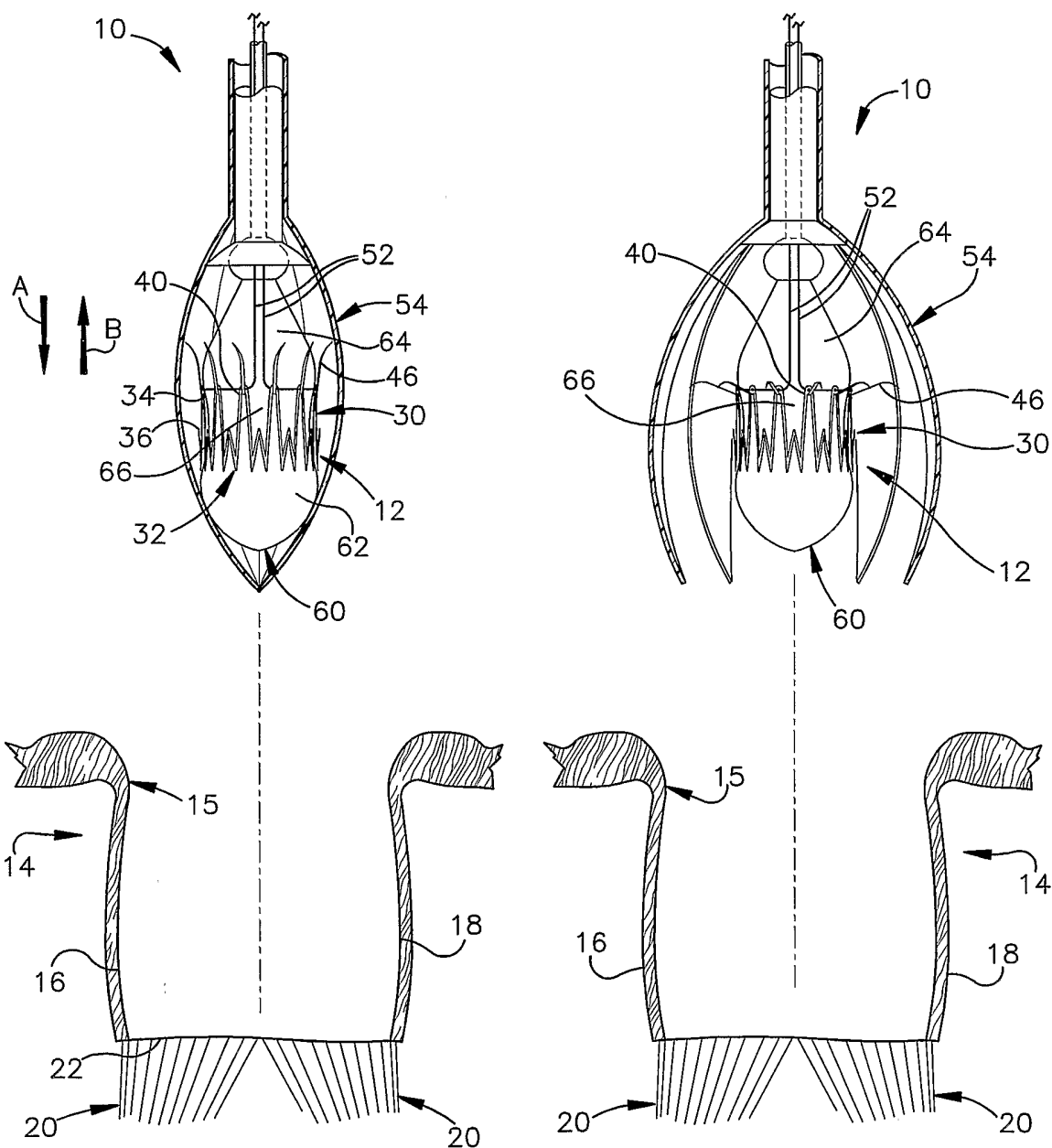

Fig.6

Fig.7

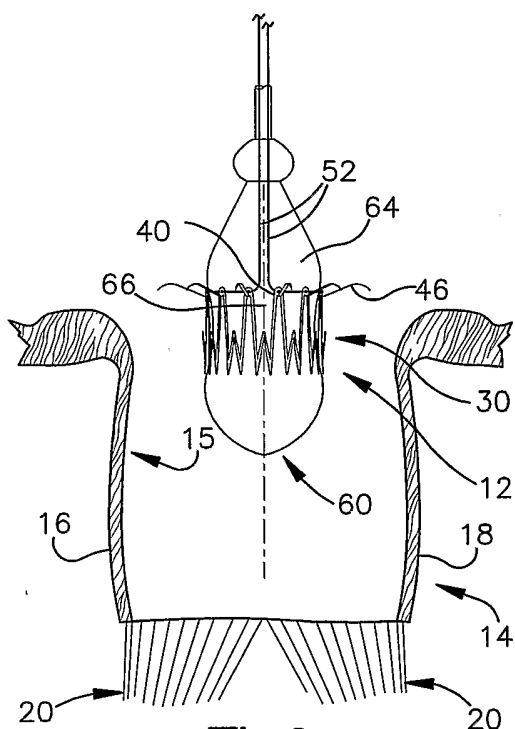

Fig.8

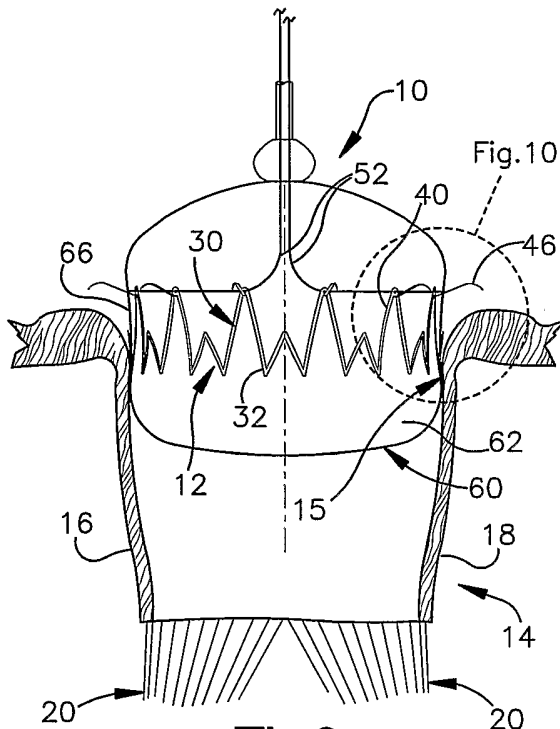

Fig.9

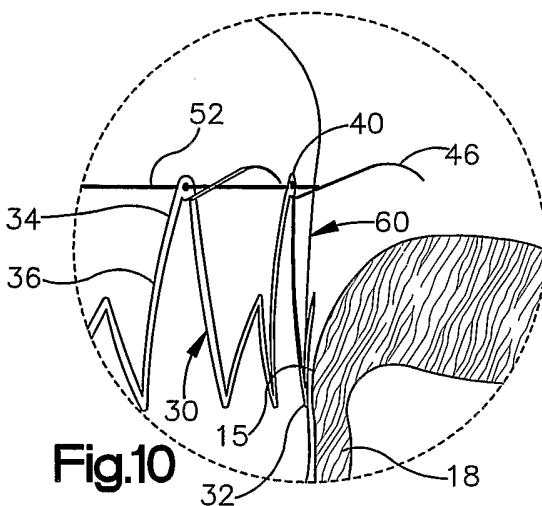
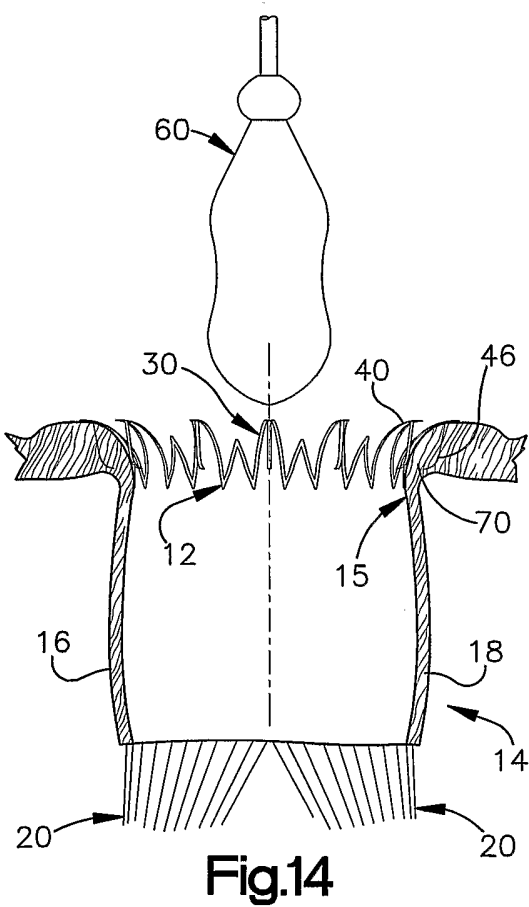
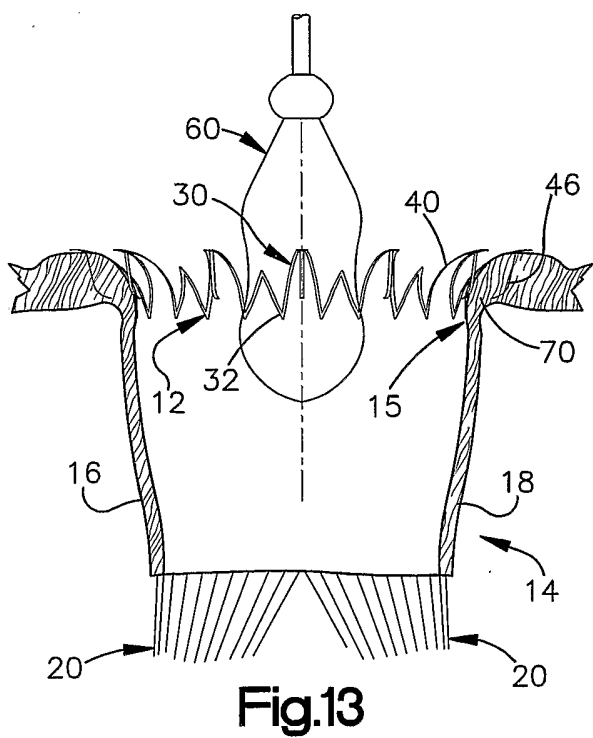
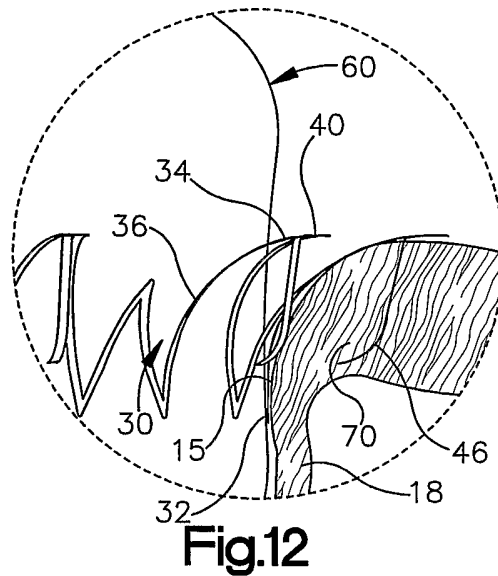
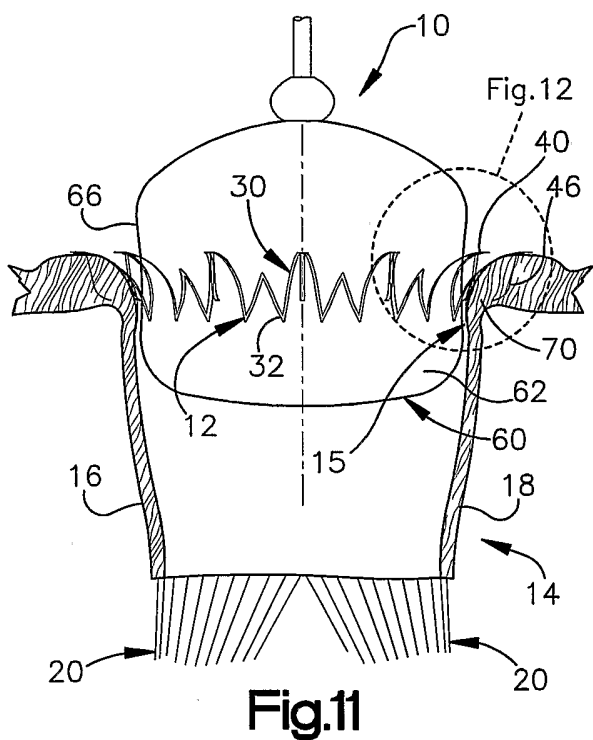

Fig.10



INTERNATIONAL SEARCH REPORT

International Application No
PCT/US2004/015770

A. CLASSIFICATION OF SUBJECT MATTER
IPC 7 A61F2/24

According to International Patent Classification (IPC) or to both national classification and IPC

B. FIELDS SEARCHED
Minimum documentation searched (classification system followed by classification symbols)
IPC 7 A61F

Documentation searched other than minimum documentation to the extent that such documents are included in the fields searched

Electronic data base consulted during the international search (name of data base and, where practical, search terms used)
EPO-Internal

Category °	Citation of document, with indication, where appropriate, of the relevant passages	Relevant to claim No.
X Y A	WO 03/028558 A (MACHOLD TIMOTHY R ; SOSS RICK A (US); CHANG ROBERT T (US); MACOVIAK JO) 10 April 2003 (2003-04-10) figures 20,36 page 11, line 13 - line 17 claim 4 -----	1,8-11, 19-21 2,12,13 3-7, 14-18,22
Y	US 2002/002401 A1 (BRIGANTI RICHARD T ET AL) 3 January 2002 (2002-01-03) figures 9b,27,28 -----	2,12,13
A	US 6 361 556 B1 (CHUTER TIMOTHY A M) 26 March 2002 (2002-03-26) figure 8 -----	1-22
	----- -/--	

Further documents are listed in the continuation of box C.

Patent family members are listed in annex.

° Special categories of cited documents :

- *A* document defining the general state of the art which is not considered to be of particular relevance
- *E* earlier document but published on or after the international filing date
- *L* document which may throw doubts on priority claim(s) or which is cited to establish the publication date of another citation or other special reason (as specified)
- *O* document referring to an oral disclosure, use, exhibition or other means
- *P* document published prior to the international filing date but later than the priority date claimed

- *T* later document published after the international filing date or priority date and not in conflict with the application but cited to understand the principle or theory underlying the invention
- *X* document of particular relevance; the claimed invention cannot be considered novel or cannot be considered to involve an inventive step when the document is taken alone
- *Y* document of particular relevance; the claimed invention cannot be considered to involve an inventive step when the document is combined with one or more other such documents, such combination being obvious to a person skilled in the art.
- *Z* document member of the same patent family

Date of the actual completion of the international search 8 October 2004	Date of mailing of the international search report 18/10/2004
Name and mailing address of the ISA European Patent Office, P.B. 5818 Patentlaan 2 NL - 2280 HV Rijswijk Tel. (+31-70) 340-2040, Tx. 31 651 epo nl, Fax: (+31-70) 340-3016	Authorized officer Franz, V

INTERNATIONAL SEARCH REPORT

International Application No
PCT/US2004/015770

C.(Continuation) DOCUMENTS CONSIDERED TO BE RELEVANT		
Category °	Citation of document, with indication, where appropriate, of the relevant passages	Relevant to claim No.
A	US 6 419 696 B1 (SPENCE PAUL A ET AL) 16 July 2002 (2002-07-16) the whole document -----	1-22
P,A	US 2003/109924 A1 (CRIBIER ALAIN) 12 June 2003 (2003-06-12) figure 3b paragraph '0033! -----	1-22

INTERNATIONAL SEARCH REPORT

International application No.
PCT/US2004/015770

Box II Observations where certain claims were found unsearchable (Continuation of item 2 of first sheet)

This International Search Report has not been established in respect of certain claims under Article 17(2)(a) for the following reasons:

1. Claims Nos.: 23-36
because they relate to subject matter not required to be searched by this Authority, namely:
Rule 39.1(iv) PCT - Method for treatment of the human or animal body by surgery
2. Claims Nos.:
because they relate to parts of the International Application that do not comply with the prescribed requirements to such an extent that no meaningful International Search can be carried out, specifically:
3. Claims Nos.:
because they are dependent claims and are not drafted in accordance with the second and third sentences of Rule 6.4(a).

Box III Observations where unity of invention is lacking (Continuation of item 3 of first sheet)

This International Searching Authority found multiple inventions in this international application, as follows:

1. As all required additional search fees were timely paid by the applicant, this International Search Report covers all searchable claims.
2. As all searchable claims could be searched without effort justifying an additional fee, this Authority did not invite payment of any additional fee.
3. As only some of the required additional search fees were timely paid by the applicant, this International Search Report covers only those claims for which fees were paid, specifically claims Nos.:
4. No required additional search fees were timely paid by the applicant. Consequently, this International Search Report is restricted to the invention first mentioned in the claims; it is covered by claims Nos.:

Remark on Protest

- The additional search fees were accompanied by the applicant's protest.
- No protest accompanied the payment of additional search fees.

INTERNATIONAL SEARCH REPORT

Information on patent family members

International Application No

PCT/US2004/015770

Patent document cited in search report		Publication date	Patent family member(s)	Publication date
WO 03028558	A	10-04-2003	CA 2455444 A1	10-04-2003
			CA 2462254 A1	10-04-2003
			EP 1434621 A2	07-07-2004
			EP 1434542 A2	07-07-2004
			WO 03028802 A2	10-04-2003
			WO 03028558 A2	10-04-2003
			US 2004138745 A1	15-07-2004
			US 2002002401	A1
			CA 2413248 A1	17-01-2002
			CA 2446596 A1	19-12-2002
			EP 1294318 A2	26-03-2003
			EP 1392197 A2	03-03-2004
			JP 2004514467 T	20-05-2004
			WO 0203893 A2	17-01-2002
			WO 02100297 A2	19-12-2002
			US 2002055772 A1	09-05-2002
			US 2004098098 A1	20-05-2004
			US 2004186561 A1	23-09-2004
			US 6527800 B1	04-03-2003
US 6361556	B1	26-03-2002	US 6517574 B1	11-02-2003
US 6419696	B1	16-07-2002	AU 6522501 A	21-01-2002
			CA 2414022 A1	17-01-2002
			CN 1440261 T	03-09-2003
			EP 1296618 A1	02-04-2003
			JP 2004502494 T	29-01-2004
			WO 0203892 A1	17-01-2002
			US 2002173841 A1	21-11-2002
			US 2004167620 A1	26-08-2004
US 2003109924	A1	12-06-2003	EP 0850607 A1	01-07-1998
			US 2003014104 A1	16-01-2003
			US 2001010017 A1	26-07-2001
			AU 5764998 A	31-07-1998
			CA 2276527 A1	09-07-1998
			WO 9829057 A1	09-07-1998
			EP 0967939 A1	05-01-2000
			US 2001007956 A1	12-07-2001