



(51) International Patent Classification:

A24F 47/00 (2020.01) A24F 42/60 (2020.01)
A24F 40/40 (2020.01)

(21) International Application Number:

PCT/EP2020/053112

(22) International Filing Date:

07 February 2020 (07.02.2020)

(25) Filing Language:

English

(26) Publication Language:

English

(30) Priority Data:

19155866.7 07 February 2019 (07.02.2019) EP

(71) Applicant: **NERUDIA LIMITED** [GB/GB]; Wellington House, Physics Road, Speke, Liverpool Merseyside L24 9HP (GB).

(72) Inventors: **MURRAY, Samantha**; C/O Nerudia Limited, Wellington House, Physics Road, Speke, Liverpool Merseyside L24 9HP (GB). **LORD, Chris**; C/O Nerudia Limited, Wellington House, Physics Road, Speke, Liverpool Merseyside L24 9HP (GB). **JONES, David**; C/O Nerudia Limited, Wellington House, Physics Road, Speke, Liverpool Merseyside L24 9HP (GB). **MARCHBANK, Jonathan**; C/O Nerudia Limited, Wellington House,

Physics Road, Speke, Liverpool Merseyside L24 9HP (GB). **SUDLOW, Tom**; C/O Nerudia Limited, Wellington House, Physics Road, Speke, Liverpool Merseyside L24 9HP (GB). **STUART, Ian**; C/O Nerudia Limited, Wellington House, Physics Road, Speke, Liverpool Merseyside L24 9HP (GB).

(74) Agent: **MEWBURN ELLIS LLP**, City Tower, 40 Basinghall Street, London Greater London EC2V 5DE (GB).

(81) Designated States (unless otherwise indicated, for every kind of national protection available): AE, AG, AL, AM, AO, AT, AU, AZ, BA, BB, BG, BH, BN, BR, BW, BY, BZ, CA, CH, CL, CN, CO, CR, CU, CZ, DE, DJ, DK, DM, DO, DZ, EC, EE, EG, ES, FI, GB, GD, GE, GH, GM, GT, HN, HR, HU, ID, IL, IN, IR, IS, JO, JP, KE, KG, KH, KN, KP, KR, KW, KZ, LA, LC, LK, LR, LS, LU, LY, MA, MD, ME, MG, MK, MN, MW, MX, MY, MZ, NA, NG, NI, NO, NZ, OM, PA, PE, PG, PH, PL, PT, QA, RO, RS, RU, RW, SA, SC, SD, SE, SG, SK, SL, ST, SV, SY, TH, TJ, TM, TN, TR, TT, TZ, UA, UG, US, UZ, VC, VN, WS, ZA, ZM, ZW.

(84) Designated States (unless otherwise indicated, for every kind of regional protection available): ARIPO (BW, GH, GM, KE, LR, LS, MW, MZ, NA, RW, SD, SL, ST, SZ, TZ, UG, ZM, ZW), Eurasian (AM, AZ, BY, KG, KZ, RU, TJ, TM), European (AL, AT, BE, BG, CH, CY, CZ, DE, DK, EE, ES, FI, FR, GB, GR, HR, HU, IE, IS, IT, LT, LU, LV,

(54) Title: SMOKING SUBSTITUTE APPARATUS

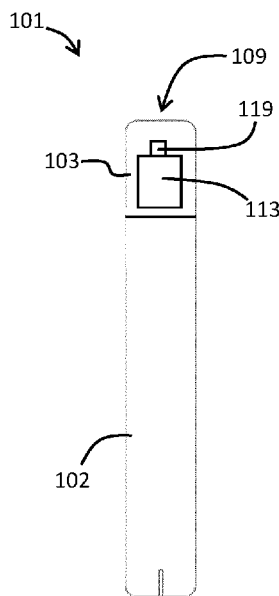

FIG 1A

(57) Abstract: Disclosed is a smoking substitute apparatus comprising a passage extending between a fluid inlet and a fluid outlet, an aerosol generator for generating an aerosol in the passage downstream of the fluid inlet, and an additive inlet in fluid communication with the passage downstream of the aerosol generator. The additive inlet is configured for connection with a pressurised additive source for supply of the additive from the additive source to the passage.



MC, MK, MT, NL, NO, PL, PT, RO, RS, SE, SI, SK, SM,
TR), OAPI (BF, BJ, CF, CG, CI, CM, GA, GN, GQ, GW,
KM, ML, MR, NE, SN, TD, TG).

Declarations under Rule 4.17:

— *of inventorship (Rule 4.17(iv))*

Published:

— *with international search report (Art. 21(3))*

SMOKING SUBSTITUTE APPARATUS

Field of the Invention

The present invention relates to a smoking substitute apparatus and, in particular, a smoking substitute apparatus that is able to deliver an additive to a user.

5 *Background*

The smoking of tobacco is generally considered to expose a smoker to potentially harmful substances. It is generally thought that a significant amount of the potentially harmful substances are generated through the heat caused by the burning and/or combustion of the tobacco and the constituents of the burnt tobacco in the tobacco smoke itself.

10 Combustion of organic material such as tobacco is known to produce tar and other potentially harmful by-products. There have been proposed various smoking substitute systems in order to avoid the smoking of tobacco.

Such smoking substitute systems can form part of nicotine replacement therapies aimed at people who wish to stop smoking and overcome a dependence on nicotine.

15 Smoking substitute systems include electronic systems that permit a user to simulate the act of smoking by producing an aerosol (also referred to as a "vapour") that is drawn into the lungs through the mouth (inhaled) and then exhaled. The inhaled aerosol typically bears nicotine and/or a flavourant without, or with fewer of, the odour and health risks associated with traditional smoking.

In general, smoking substitute systems are intended to provide a substitute for the rituals of smoking,
20 whilst providing the user with a similar experience and satisfaction to those experienced with traditional smoking and with combustible tobacco products.

The popularity and use of smoking substitute systems has grown rapidly in the past few years. Although originally marketed as an aid to assist habitual smokers wishing to quit tobacco smoking, consumers are increasingly viewing smoking substitute systems as desirable lifestyle accessories. There are a number
25 of different categories of smoking substitute systems, each utilising a different smoking substitute approach.

One approach is the so-called "vaping" approach, in which a vaporisable liquid, typically referred to (and referred to herein) as "e-liquid", is heated by a heating device (referred to herein as an electronic cigarette or "e-cigarette" device) to produce an aerosol vapour which is inhaled by a user. The e-liquid typically
30 includes a base liquid as well as nicotine and/or a flavourant. The resulting vapour therefore also typically contains nicotine and/or a flavourant. The base liquid may include propylene glycol and/or vegetable glycerine.

A typical e-cigarette device includes a mouthpiece, a power source (typically a battery), a tank for containing e-liquid, as well as a heating device. In use, electrical energy is supplied from the power

source to the heating device, which heats the e-liquid to produce an aerosol (or “vapour”) which is inhaled by a user through the mouthpiece.

E-cigarettes can be configured in a variety of ways. For example, there are “closed system” vaping smoking substitute systems, which typically have a sealed tank and heating element. The tank is pre-filled with e-liquid and is not intended to be refilled by an end user. One subset of closed system vaping smoking substitute systems include a main body which includes the power source, wherein the main body is configured to be physically and electrically coupled to a consumable including the tank and the heating element. In this way, when the tank of a consumable has been emptied, that consumable is disposed of. The main body can be reused by connecting it to a new, replacement, consumable. Another subset of closed system vaping smoking substitute systems are completely disposable, and intended for one-use only.

There are also “open system” vaping smoking substitute systems which typically have a tank that is configured to be refilled by a user. In this way the entire device can be used multiple times.

An example vaping smoking substitute system is the myblu™ e-cigarette. The myblu™ e-cigarette is a closed system which includes a main body and a consumable. The main body and consumable are physically and electrically coupled together by pushing the consumable into the main body. The main body includes a rechargeable battery. The consumable includes a mouthpiece, a sealed tank which contains e-liquid, as well as a heater, which for this device is a heating filament coiled around a portion of a wick. The wick is partially immersed in the e-liquid, and conveys e-liquid from the tank to the heating filament. The device is activated when a microprocessor on board the main body detects a user inhaling through the mouthpiece. When the device is activated, electrical energy is supplied from the power source to the heating device, which heats e-liquid from the tank to produce a vapour which is inhaled by a user through the mouthpiece.

For a smoking substitute device it is desirable to deliver nicotine into the user’s lungs, where it can be absorbed into the bloodstream. As explained above, in the so-called “vaping” approach, e-liquid is heated by a heating device to produce an aerosol vapour which is inhaled by a user. Many e-cigarettes also deliver flavour to the user to enhance the experience. In such e-cigarettes, flavour compounds are contained in the e-liquid that is heated. However, toxicology restrictions are placed on the amount of flavour that can be contained in the e-liquid, and this can result in some e-liquid flavours delivering a weak and underwhelming taste sensation to consumers in the pursuit of safety. Further, there is a view that providing a flavourant as part of the e-liquid, such that the flavourant is vaporised with the e-liquid, may be disadvantageous.

There may be a need for improved design of smoking substitute systems, in particular in regards to the delivery of additives (such as flavour providing additives) to a user.

The present disclosure has been devised in the light of the above considerations.

Summary of the Invention

At its most general, the present invention relates a smoking substitute apparatus for use with a source of pressurised additive.

5 According to a first aspect there provided a smoking substitute apparatus comprising: a passage extending between a fluid inlet and a fluid outlet, an aerosol generator for generating an aerosol in the passage downstream of the fluid inlet, and an additive inlet in fluid communication with the passage downstream of the aerosol generator, the additive inlet configured for connection with a pressurised additive source for supply of an additive from the additive source to the passage.

10 Providing an additive that is separate to the e-liquid may provide more versatility in how the additive can be delivered to the user. Further, the provision of a pressurised source of additive may allow the storage of a larger quantity of an additive in a smaller space. In this way, the apparatus (when used with the source of additive) may be smaller in overall size, so as to be more easily handled by a user.

15 The additive may be in e.g. liquid or powder form. The additive may comprise a flavourant. The term "flavourant" is used to describe a compound or combination of compounds that provide flavour and/or aroma. For example, the flavourant may be configured to interact with a sensory receptor of a user (such as an olfactory or taste receptor). The flavourant may include one or more volatile substances.

20 The flavourant may be provided in solid (e.g. a powder) or liquid form. The flavourant may be natural or synthetic. For example, the flavourant may include menthol, liquorice, chocolate, fruit flavour (including e.g. citrus, cherry etc.), vanilla, spice (e.g. ginger, cinnamon) and tobacco flavour. The flavourant may dispersed throughout e.g. a base fluid. The flavourant may be evenly dispersed or may be provided in isolated locations and/or varying concentrations.

The outlet of the passage may be at a mouthpiece of the smoking substitute apparatus. In this respect, a user may draw fluid (e.g. air) into and through the passage by inhaling at the outlet (i.e. using the mouthpiece).

25 The smoking substitute apparatus may comprise a valve fluidly connected between the additive inlet and the passage for controlling the flow of additive from the inlet to the passage. The valve may be a one-way directional valve or a check valve. The valve may be movable between an open position and a closed position. In the open position additive may be able to flow from the inlet to the passage. In the closed position the flow of additive from the inlet to the passage may be substantially (or fully) prevented.
30 That is, in the closed position the valve may substantially obstruct the inlet. The valve may be biased towards the closed position. This may prevent leakage of the additive from the source when the apparatus is not in use.

35 The valve may be configured to move from the closed position to the open position in response to fluid flow through the passage. The valve may be configured to move from the closed position to the open position in response to an inhalation from the outlet by a user. For example, the valve may be configured to move from the closed position to the open position in response to a pressure drop in the passage,

which may be a result of an inhalation by a user at the outlet. In this respect, a force retaining the valve in a closed position may be the same (or slightly larger) than the force exerted on the valve from the pressurised contents of the receptacle such that an additional force (due to a pressure drop caused by inhalation) causes the valve to open. The valve may be configured to remain open during inhalation by the user.

In this way, additive (such as a flavourant) may be delivered from the additive source to the passage (and to the fluid outlet) during inhalation by a user. When a user is not inhaling at the outlet the valve may remain in the closed position. Thus, additive may only be delivered (or discharged) from the receptacle when required (i.e. during inhalation).

The valve may be controlled by other means (i.e. other than inhalation at the outlet). For example, the valve may be moved by an actuator controlled by a controller (e.g. forming part of the apparatus or in operative connection with the apparatus). The controller may cause the valve to open (move to the open position) upon receipt of a signal from a sensor. In one example, the sensor (e.g. a puff sensor) may detect inhalation at the outlet and the controller may open the valve upon receipt of a signal indicative of an inhalation at the outlet by a user. Such a sensor may be in the form of a pressure sensor or an acoustic sensor.

The valve may alternatively be controlled by a user input. For example, the apparatus may comprise a button that, when pressed by a user, may cause the valve to open. The button may be operatively connected to the valve (or an actuator of the valve) electrically (e.g. via a controller) or mechanically (e.g. by a mechanical linkage).

The smoking substitute apparatus may comprise a connector for releasable connection with a pressurised receptacle comprising the additive source. The connector may form part of, or be located at, the additive inlet. The connector may comprise a threaded connection, bayonet connection, snap-fit connection, bumps, detents, clips, etc. The connector may be configured such that, when connected with the receptacle, a seal is created between the receptacle and the additive inlet. The connector may comprise a sealing member (e.g. such as a sealing ring) to provide a seal between the receptacle and the inlet.

The connector may comprises a seal breaching portion for breaching a seal of the receptacle upon connection with the connector. For example, the seal breaching portion may comprise one or more protrusions for piercing a seal of the receptacle. The one or more protrusions may be pointed or may have a tapered cutting edge. The breaching portion may be arranged such that the seal is only breached once the receptacle and the additive inlet are connected (i.e. and a seal is formed between them). This may avoid additive leakage while connecting the receptacle to the additive inlet.

The smoking substitute apparatus may comprise a conduit extending between the passage and the additive inlet. The apparatus may comprise a housing through which the passage extends along a longitudinal axis. The conduit may extend laterally from the passage to the additive inlet (i.e. in a general lateral direction). The additive inlet may be at an outer surface of the housing. The connector may be

integral with the housing or may be a separately formed component. The conduit may comprise a nozzle for dispersing additive into the passage.

5 The substitute smoking apparatus may comprise first and second portions. The first portion may comprise the aerosol generator and a first section of the passage. The second portion may comprise the additive inlet and a second section of the passage. The second portion may be removably mountable to the first portion such that the first and second sections of passage are fluidly connected, so as to define the passage.

The second portion may comprises the pressurised additive source. The pressurised additive source may be in the form of a cavity containing additive under pressure formed within the second portion.

10 The smoking substitute apparatus may be in the form of a consumable for e.g. an e-cigarette device. The consumable may be configured for engagement with a main body (i.e. so as to form a closed smoking substitute system). For example, the consumable may comprise components of the system that are disposable, and the main body may comprise non-disposable or non-consumable components (e.g. power supply, controller, sensor, etc.) that facilitate the delivery of aerosol by the consumable. In such an
15 embodiment, the aerosol former (e.g. e-liquid) may be replenished by replacing a used consumable with an unused consumable.

Alternatively, the smoking substitute apparatus may be a non-consumable apparatus (e.g. that is in the form of an open smoking substitute system). In such embodiments an aerosol former (e.g. e-liquid) of the system may be replenished by re-filling e.g. a reservoir of the smoking substitute apparatus with the
20 aerosol former (rather than replacing a consumable component of the apparatus).

In light of this, it should be appreciated that some of the features described below as being part of the smoking substitute apparatus may alternatively form part of a main body for engagement with the smoking substitute apparatus (i.e. when the smoking substitute apparatus is in the form of a consumable).

25 Where the smoking substitute apparatus is in the form of a consumable, the main body and the consumable may be configured to be physically coupled together. For example, the consumable may be at least partially received in a recess of the main body, such that there is an interference fit between the main body and the consumable. Alternatively, the main body and the consumable may be physically coupled together by screwing one onto the other, or through a bayonet fitting.

30 Thus, the smoking substitute apparatus may comprise one or more engagement portions for engaging with a main body. In this way, one end of the smoking substitute apparatus may be coupled with the main body, whilst an opposing end of the smoking substitute apparatus may define a mouthpiece of a smoking substitute system.

The smoking substitute apparatus may comprise a reservoir configured to store an aerosol former, such as an e-liquid. The e-liquid may, for example, comprise a base liquid and e.g. nicotine. The base liquid
35 may include propylene glycol and/or vegetable glycerine. The e-liquid may be flavourless. That is, the e-

liquid may not contain any flavourants and may consist solely of a base liquid of propylene glycol and/or vegetable glycerine and nicotine.

5 The reservoir may be in the form of a tank. At least a portion of the tank may be translucent. For example, the tank may comprise a window to allow a user to visually assess the quantity of e-liquid in the tank. A housing of the smoking substitute apparatus may comprise a corresponding aperture (or slot) or window that may be aligned with a translucent portion (e.g. window) of the tank. The reservoir may be referred to as a "clearomizer" if it includes a window, or a "cartomizer" if it does not.

The passage may be at least partially defined by the tank. The tank may substantially (or fully) define the passage. In this respect, the tank may surround the passage.

10 The aerosol generator may comprise a wick. The aerosol generator may further comprise a heater. The wick may comprise a porous material. A portion of the wick may be exposed to fluid flow in the passage. The wick may also comprise one or more portions in contact with liquid stored in the reservoir. For example, opposing ends of the wick may protrude into the reservoir and a central portion (between the ends) may extend across the passage so as to be exposed to fluid flow in the passage. Thus, fluid may
15 be drawn (e.g. by capillary action) along the wick, from the reservoir to the exposed portion of the wick.

The heater may comprise a heating element, which may be in the form of a filament wound about the wick (e.g. the filament may extend helically about the wick). The filament may be wound about the exposed portion of the wick. The heating element may be electrically connected (or connectable) to a power source. Thus, in operation, the power source may supply electricity to (i.e. apply a voltage across)
20 the heating element so as to heat the heating element. This may cause liquid stored in the wick (i.e. drawn from the tank) to be heated so as to form a vapour and become entrained in fluid flowing through the passage. This vapour may subsequently cool to form an aerosol in the passage. The aerosol (or vapour) may mix with additive supplied via the additive inlet prior to being inhaled at the mouthpiece. In this way the

25 The smoking substitute apparatus (or main body engaged with the smoking substitute apparatus) may comprise a power source. The power source may be electrically connected (or connectable) to a heater of the smoking substitute apparatus (e.g. when engaged with the main body). The power source may be a battery (e.g. a rechargeable battery). A connector in the form of e.g. a USB port may be provided for recharging this battery.

30 When the smoking substitute apparatus is in the form of a consumable, the smoking substitute apparatus may comprise an electrical interface for interfacing with a corresponding electrical interface of the main body. One or both of the electrical interfaces may include one or more electrical contacts. Thus, when the main body is engaged with the consumable, the electrical interface may be configured to transfer electrical power from the power source to a heater of the consumable.

35 The electrical interface may also be used to identify the smoking substitute apparatus (in the form of a consumable) from a list of known types. For example, the consumable may have a certain concentration

of nicotine and the electrical interface may be used to identify this. The electrical interface may additionally or alternatively be used to identify when a consumable is connected to the main body.

Again, where the smoking substitute apparatus is in the form of a consumable, the main body may comprise an interface, which may, for example, be in the form of an RFID reader, a barcode or QR code reader. This interface may be able to identify a characteristic (e.g. a type) of a consumable engaged with
5 the main body. In this respect, the consumable may include any one or more of an RFID chip, a barcode or QR code, or memory within which is an identifier and which can be interrogated via the interface.

The smoking substitute apparatus or main body may comprise a controller, which may include a microprocessor. The controller may be configured to control the supply of power from the power source
10 to the heater of the smoking substitute apparatus (e.g. via the electrical contacts). A memory may be provided and may be operatively connected to the controller. The memory may include non-volatile memory. The memory may include instructions which, when implemented, cause the controller to perform certain tasks or steps of a method. For example, and as is provided above, the controller may operate e.g. an actuator, to move the valve so as to control additive flow into the passage.

15 The main body or smoking substitute apparatus may comprise a wireless interface, which may be configured to communicate wirelessly with another device, for example a mobile device, e.g. via Bluetooth®. To this end, the wireless interface could include a Bluetooth® antenna. Other wireless communication interfaces, e.g. WiFi®, are also possible. The wireless interface may also be configured to communicate wirelessly with a remote server.

20 A puff sensor may be provided that is configured to detect a puff (i.e. inhalation from a user). The puff sensor may be operatively connected to the controller so as to be able to provide a signal to the controller that is indicative of a puff state (i.e. puffing or not puffing). As provided above, the puff sensor may, for example, be in the form of a pressure sensor or an acoustic sensor. That is, the controller may control power supply to the heater of the consumable in response to a puff detection by the sensor. The control
25 may be in the form of activation of the heater in response to a detected puff. That is, the smoking substitute apparatus may be configured to be activated when a puff is detected by the puff sensor. The puff sensor may be operatively connected (e.g. via a controller) to the valve so as to move the valve to the open position when a puff is detected. When the smoking substitute apparatus is in the form of a consumable, the puff sensor may form part of the consumable or the main body.

30 In a second aspect, there is provided a smoking substitute system comprising: a smoking substitute apparatus according to the first aspect, and a receptacle comprising a cavity for containing a pressurised additive, the receptacle for connection to the smoking substitute apparatus such that the cavity is in fluid communication with the passage downstream of the aerosol generator.

As is set forth above, the smoking substitute apparatus of the second aspect is as described above with
35 respect to the first aspect. Thus, for example, the smoking substitute apparatus of the second aspect may comprise a valve, connector, housing, conduit, etc. as described above with respect to the first aspect.

The receptacle may be integral with the smoking substitute apparatus (and, in this respect, may be considered a part of the smoking substitute apparatus). The receptacle may be mounted to the smoking substitute apparatus. The receptacle may be releasably mountable to the smoking substitute apparatus. The receptacle may be formed of a plastic or metal material. The receptacle is pressurised. That is, the contents are contained by the receptacle under a pressure that is greater than atmospheric pressure.

The receptacle may comprises a valve for controlling the flow of additive from the cavity. The valve may be the same as that described above with respect to the first aspect (except that it forms part of the receptacle rather than part of the apparatus). Thus, the valve may be movable between an open position in which the additive is able to flow from the cavity, and a closed position in which the additive is prevented from flowing from the cavity. The valve may be biased towards the closed position. The valve may be configured to move from the closed position to the open position in response to fluid flow through the passage, when the receptacle is mounted to the smoking substitute apparatus. The valve may be configured to move from the closed position to the open position in response to an inhalation from the outlet by a user. The valve may be a check valve or a one-way valve.

The receptacle may comprise a connector for releasably connecting the receptacle to the smoking substitute apparatus. The connector may complement, or correspond to, a connector of the apparatus. The connector may comprise a threaded connection, bayonet connection, snap-fit connection, bumps, detents, clips, etc. The connector may be configured such that, when connected with the apparatus, a seal is created between the receptacle and the additive inlet of the apparatus. The connector may comprise a sealing member (e.g. such as a sealing ring) to provide a seal between the receptacle and the inlet. The connector may be configured to connect with the apparatus at or proximate to the additive inlet. Alternatively, the connector may be distal from the additive inlet (e.g. the connector may be in the form of a pair of arms wrapping around a housing of the apparatus or a further body (e.g. the main body) to which the apparatus is mounted).

The receptacle may comprise an opening for release of additive from the cavity and a seal for sealing the opening. The seal may be in the form of a removable seal. For example, the seal may comprise a barrier portion or covering the opening and a tab extending from the covering portion to facilitate removal of the seal by a user. Alternatively, the removable seal may be in the form of e.g. a cap. The seal may alternatively be in the form of a frangible seal extending across the opening. The frangible portion may be a region of thinner and/or weaker material (e.g. a foil).

The additive may be in e.g. liquid or powder form or a combination. The additive may comprise a flavourant. Alternatively, or additionally the additive may comprise a colourant or a coolant. As is set forth above, the flavourant may be provided in solid (e.g. a powder) or liquid form. The flavourant may be natural or synthetic. For example, the flavourant may include menthol, liquorice, chocolate, fruit flavour (including e.g. citrus, cherry etc.), vanilla, spice (e.g. ginger, cinnamon) and tobacco flavour. The flavourant may dispersed throughout e.g. a base fluid. The flavourant may be evenly dispersed or may be provided in isolated locations and/or varying concentrations.

The additive may comprise a propellant. The propellant may be in the form of a gas pressurised within the receptacle. A flavourant (or other additive component) may be mixed with the propellant. Thus, the additive may be pressurised within the receptacle. For example, the cavity of the receptacle may have a pressure of between 50 to 750 kPa. The cavity of the receptacle may have a pressure of between 125 to 550 kPa. The cavity of the receptacle may have a pressure of between 300 to 500 kPa. The pressure in the cavity may be such that the additive (i.e. received through the outlet) is discharged at a velocity that is suitable for receipt in a user's mouth.

In a third aspect there is provided an additive delivery article for supplying an additive to a smoking substitute apparatus, the additive delivery article comprising: a cavity for containing the additive under pressure, an outlet for releasing additive from the cavity, a connector portion for connecting the outlet to an additive inlet of the smoking substitute article, and a valve between the cavity and the outlet, the valve configured to move from a closed position in which flow of additive from the cavity is prevented and an open position in which additive is able to flow from the cavity to the outlet in response to a drop in pressure at the outlet.

The pressure drop may correspond to a user inhaling from a mouthpiece opening of the smoking substitute apparatus in fluid connection with the outlet of the flavour delivery article when connected thereto.

In a fourth aspect there is provided a method of delivering an aerosol comprising an additive, the method comprising generating an aerosol flow, supplying an additive from a pressurised container to the aerosol flow to form a combined flow, and delivering the combined flow to a user.

The invention includes the combination of the aspects and preferred features described except where such a combination is clearly impermissible or expressly avoided.

Summary of the Figures

So that the invention may be understood, and so that further aspects and features thereof may be appreciated, embodiments illustrating the principles of the invention will now be discussed in further detail with reference to the accompanying figures, in which:

Figure 1A is a front view of a smoking substitute system, according to a first embodiment, in an engaged position;

Figure 1B is a front view of the smoking substitute system of the first embodiment in a disengaged position;

Figure 1C is a detailed section view of the smoking substitute system of the first embodiment;

Figure 1D is a further detailed section view of the smoking substitute apparatus of the first embodiment during engagement with a receptacle;

Figure 1E is a further detailed section view of a smoking substitute apparatus of the first embodiment engaged with a receptacle; and

Figure 2 is section view of a smoking substitute apparatus according to a second embodiment.

Detailed Description of the Invention

Aspects and embodiments of the present invention will now be discussed with reference to the accompanying figures. Further aspects and embodiments will be apparent to those skilled in the art. All documents mentioned in this text are incorporated herein by reference.

Figures 1A and 1B illustrate a smoking substitute system in the form of an e-cigarette system 101. The system 101 comprises an e-cigarette device defining a main body 102 of the system 101, and an smoking substitute apparatus in the form of an e-cigarette consumable (or "pod") 103. In the illustrated embodiment the consumable 103 (smoking substitute apparatus) is removable from the main body (e-cigarette device), so as to be a replaceable component of the system 101. In other words, the e-cigarette system 101 is a closed system.

As is apparent from Figures 1A and 1B, the consumable 103 is configured to engage the main body 102. Figure 1A shows the main body 102 and the consumable 103 in an engaged state, whilst Figure 1B shows the main body 102 and the consumable 103 in a disengaged state. When engaged, a portion of the consumable 103 is received in a cavity of the main body 102 and is retained in the engaged position by way of a snap-engagement mechanism. In other embodiments, the main body 102 and consumable 103 may be engaged by screwing one into (or onto) the other, through a bayonet fitting, or by way of an interference fit.

The system 101 is configured to vaporise an aerosol-former, which in the illustrated embodiment, is in the form of a nicotine-based e-liquid 104. The e-liquid 104 comprises nicotine and a base liquid including propylene glycol and/or vegetable glycerine. In the present embodiment, the e-liquid 104 is flavourless (and does not include any added flavourant). That is, if the e-liquid 104 were to be inhaled (i.e. in aerosol form) by a user, it would not have a particularly perceptible flavour or taste.

As is more apparent from Figure 1C, this e-liquid 104 is stored within a reservoir in the form of a tank 105 that forms part of the consumable 103. In the illustrated embodiment, the consumable 103 is a "single-use" consumable 103. That is, upon exhausting the e-liquid 104 in the tank 105, the intention is that the user disposes of the entire consumable 103. In other embodiments, the e-liquid (i.e. aerosol former) may be the only part of the system that is truly "single-use". That is, the tank may be refillable with e-liquid or the e-liquid may be stored in a non-consumable component of the system. For example, the e-liquid may be stored in a tank located in the main body or stored in another component that is itself not single-use (e.g. a refillable cartomizer).

The tank 105 surrounds, and thus defines a portion of, a passage 106 that extends between an inlet 107 and an outlet 108 at opposing ends of the consumable 103. In this respect, the passage comprises an upstream end at the end of the consumable 103 that engages with the main body 102, and a downstream end at an opposing end of the consumable 103 that comprises a mouthpiece 109 of the system 101. When the consumable 103 is engaged with the main body 102, a user can inhale (i.e. take a puff) via the

mouthpiece 109 so as to draw air through the passage 106, and so as to form an airflow (indicated by arrows) in a direction from the inlet 107 to the outlet 108 of the passage 106. Although not illustrated, the passage 106 may be partially defined by a tube (e.g. a metal tube) extending through the consumable 103. The passage 106 is in fluid communication with a gap defined between the consumable 103 and the main body 102 (when engaged) such that air outside of the system 101 is drawn into the passage 106 (during an inhale).

The smoking substitute system 101 is configured to vaporise the e-liquid 104 for inhalation by a user. To provide this, the consumable 103 comprises a heater having of a porous wick 110 and a resistive heating element in the form of a heating filament 111 that is helically wound around a portion of the porous wick 110. The porous wick 110 extends across the passage 106 (i.e. transverse to a longitudinal axis of the passage 106) and opposing ends of the wick 110 extend into the tank 105 (so as to be submerged in the e-liquid 104). In this way, e-liquid 104 contained in the tank 105 is conveyed from the opposing ends of the porous wick 110 to a central portion of the porous wick 110 so as to be exposed to the airflow in the passage 106 (i.e. caused by a user inhaling).

The helical filament 111 is wound about this exposed central portion of the porous wick 110 and is electrically connected to an electrical interface in the form of electrical contacts 112 mounted at the end of the consumable that is proximate the main body 102 (when engaged). When the consumable 103 is engaged with the main body 102, the electrical contacts 112 contact corresponding electrical contacts (not shown) of the main body 102. The main body electrical contacts are electrically connected to a power source (not shown) of the main body 102, such that (in the engaged position) the filament 111 is electrically connected to the power source. In this way, power can be supplied by the main body 102 to the filament 111 in order to heat the filament 111. This heat is transferred from the filament 111 to the porous wick 110 which causes e-liquid 104 conveyed by the porous wick 110 to increase in temperature to a point at which it vaporises. The vaporised e-liquid becomes entrained in the airflow and, between the vapourisation point at the filament 111 and the outlet 108 of the passage 106, condenses to form an aerosol. This aerosol is then inhaled, via the mouthpiece 109, by a user of the system 101.

The power source of the main body 102 may be in the form of a battery (e.g. a rechargeable battery). The main body 102 may comprise a connector in the form of e.g. a USB port for recharging this battery. The main body 102 may also comprise a controller that controls the supply of power from the power source to the main body electrical contacts (and thus to the filament 111). That, is the controller may be configured to control a voltage applied across the main body electrical contacts, and thus the voltage applied across the filament 111. In this way, the filament 111 may only be heated under certain conditions (e.g. during a puff and/or only when the system is in an active state). In this respect, the main body 102 may include a puff sensor (not shown) that is configured to detect a puff (i.e. inhalation). The puff sensor may be operatively connected to the controller so as to be able to provide a signal, to the controller, which is indicative of a puff state (i.e. puffing or not puffing). The puff sensor may, for example, be in the form of a pressure sensor or an acoustic sensor.

Although not shown, the main body 102 and consumable 103 may comprise a further interface which may, for example, be in the form of an RFID reader, a barcode or QR code reader. This interface may be able to identify a characteristic (e.g. a type) of a consumable 103 engaged with the main body 102. In this respect, the consumable 103 may include any one or more of an RFID chip, a barcode or QR code, or memory within which is an identifier and which can be interrogated via the interface.

As is apparent from Figures 1C and 1D, the smoking substitute system 101 further comprises an additive source in the form of a receptacle 113 (formed of e.g. metal or plastic) comprising a cavity 114 for containing a pressurised additive (i.e. contained above atmospheric pressure) which, in the present embodiment, comprises a flavourant (for delivering flavour to a user).

In order to deliver the additive to a user, the consumable 103 comprises an additive inlet 115 in fluid communication with the passage 106 downstream of the wick 110. The additive inlet 115 is formed in an outer surface of a housing 116 of the consumable 103 and is fluidly connected to the passage 106 by a conduit 117. This conduit 117 extends generally laterally with respect to the passage 106, but is not perpendicular to the passage 106, so as to provide for a smooth flow of additive from the conduit 117 to the passage 106. As will be described further below, the inlet 115 is configured for connection with the receptacle 113 for supply of the additive from the cavity 114 of the receptacle 113.

To control the flow of additive, the consumable 103 comprises a valve 116 between the additive inlet 115 and the passage 106 (i.e. in the conduit 117). The valve 118 may be a one-way directional valve or a check valve. The valve 118 is movable between an open position (Figure 1E) and a closed position (Figure 1D). In the open position additive is able to flow from the inlet 115 to the passage 106. In the closed position the valve 118 obstructs the inlet 115 and flow of additive from the inlet 115 to the passage 106 is prevented. The valve 118 is biased towards the closed position.

Although not immediately apparent from the figures, the valve 118 is configured to move from the closed position to the open position in response to an inhalation from the outlet 108 by a user. In other words, inhalation at the outlet 108 causes a pressure drop in the conduit 117. The differential pressure across the valve 118 causes the valve 118 to move from the closed position to the open position. Thus, when a user is inhaling the valve 118 is in the open position and additive is combined with the aerosol flow in the passage 106. Conversely, when a user is not inhaling, the valve 118 remains in the closed position (as shown in Figure 1D).

For releasable connection (i.e. mounting) of the receptacle 113 to the consumable 103, the consumable comprises a connector 119. In the illustrated embodiment the connector 119 operates by way of a snap-fit mechanism. In particular, the connector 119 comprises bump features 120 that are configured to engage with corresponding grooves 121 formed in an outer surface of the receptacle 113. As the receptacle 113 is moved into connection with the connector 119 (as indicated by the arrow of Figure 1D) the outermost bump feature 120 is deflected by an outer surface of the receptacle 113, until it reaches the corresponding groove 121 and engages with the groove 121.

The connector 119 comprises a sealing member in the form of an elastomeric sealing ring 122. This sealing ring 122 is compressed as the receptacle 113 engages with the connector 119 so as to form a fluid seal between the receptacle 113 and the connector 119. This prevents leakage of pressurised additive between the receptacle 113 and the connector 119.

5 To prevent leakage of the pressurised additive prior to connection of the receptacle 113 with the connector 119, the receptacle 113 comprises a frangible seal 123 (or membrane) that extends across an opening of the receptacle 113. The frangible seal 123 is a thinner piece of material (e.g. foil) that may be integrally formed with the receptacle 113 or attached in another manner. In order to release additive from the cavity 114 (upon connection of the receptacle 113 to the connector 119), the connector 119
10 comprises a seal breaching portion in the form of a tapered ring 124 extending about an opening to the connector 119 (in fluid connection with the inlet 115). The ring 124 is tapered from its base to a distal end so as to be pointed. Thus, the ring is able to pierce the frangible seal 123 to release pressurised additive from the cavity 114 of the receptacle 113. As is shown by the dashed arrows of Figure 1E, this allows the additive to flow from the receptacle, through the inlet 115 and to the passage 106 (via the conduit 117).
15 The additive then mixes with aerosol (generated at the wick 110) and may be inhaled via the outlet 108 by a user. In this way, the additive may change a property (e.g. flavour) of the aerosol inhaled by the user.

Figure 2 shows a further embodiment of a smoking substitute apparatus, again in the form of a consumable 203. This consumable 203 differs from the previously described consumable 103, in that it
20 comprises first 225 and second 226 portions that are releasably mountable to one another (e.g. by a screw connection, bayonet connection, snap engagement, etc.). The first portion 225 comprises the receptacle 113 and a first passage section 206a. The second portion 226 comprises the remaining components of the consumable 103 (e.g. generator, wick, heater, etc. (not shown)), and a second passage section 206b. When the first 225 and second 226 portions are mounted together, the first 206a
25 and second 206b passage sections define the passage of the consumable 103.

The features disclosed in the foregoing description, or in the following claims, or in the accompanying drawings, expressed in their specific forms or in terms of a means for performing the disclosed function, or a method or process for obtaining the disclosed results, as appropriate, may, separately, or in any combination of such features, be utilised for realising the invention in diverse forms thereof.

30 While the invention has been described in conjunction with the exemplary embodiments described above, many equivalent modifications and variations will be apparent to those skilled in the art when given this disclosure. Accordingly, the exemplary embodiments of the invention set forth above are considered to be illustrative and not limiting. Various changes to the described embodiments may be made without departing from the spirit and scope of the invention.

35 For the avoidance of any doubt, any theoretical explanations provided herein are provided for the purposes of improving the understanding of a reader. The inventors do not wish to be bound by any of these theoretical explanations.

Any section headings used herein are for organizational purposes only and are not to be construed as limiting the subject matter described.

Throughout this specification, including the claims which follow, unless the context requires otherwise, the words "have", "comprise", and "include", and variations such as "having", "comprises", "comprising", and "including" will be understood to imply the inclusion of a stated integer or step or group of integers or steps but not the exclusion of any other integer or step or group of integers or steps.

It must be noted that, as used in the specification and the appended claims, the singular forms "a," "an," and "the" include plural referents unless the context clearly dictates otherwise. Ranges may be expressed herein as from "about" one particular value, and/or to "about" another particular value. When such a range is expressed, another embodiment includes from the one particular value and/or to the other particular value. Similarly, when values are expressed as approximations, by the use of the antecedent "about," it will be understood that the particular value forms another embodiment. The term "about" in relation to a numerical value is optional and means, for example, +/- 10%.

The words "preferred" and "preferably" are used herein refer to embodiments of the invention that may provide certain benefits under some circumstances. It is to be appreciated, however, that other embodiments may also be preferred under the same or different circumstances. The recitation of one or more preferred embodiments therefore does not mean or imply that other embodiments are not useful, and is not intended to exclude other embodiments from the scope of the disclosure, or from the scope of the claims.

20

Claims:

1. A smoking substitute apparatus comprising:
 - a passage extending between a fluid inlet and a fluid outlet;
 - an aerosol generator for generating an aerosol in the passage downstream of the fluid inlet; and
 - 5 an additive inlet in fluid communication with the passage downstream of the aerosol generator, the additive inlet configured for connection with a pressurised additive source for supply of an additive from the additive source to the passage.
2. A smoking substitute apparatus according to claim 1 comprising a valve fluidly connected between the additive inlet and the passage for controlling the flow of additive from the inlet to the passage.
- 10 3. A smoking substitute apparatus according to claim 1 or 2 wherein the valve is movable between:
 - an open position in which the additive is able to flow from the inlet to the passage; and
 - a closed position in which the flow of additive from the inlet to the passage is substantially prevented.
4. A smoking substitute apparatus according to claim 3 wherein the valve is configured to move from the closed position to the open position in response to fluid flow through the passage.
- 15 5. A smoking substitute apparatus according to claim 4 wherein the valve is configured to move from the closed position to the open position in response to an inhalation from the outlet by a user.
6. A smoking substitute apparatus according to any one of the preceding claims comprising a connector for releasable connection with a pressurised receptacle comprising the additive source.
- 20 7. A smoking substitute apparatus according to claim 6 wherein the connector comprises a seal breaching portion for breaching a seal of the receptacle upon connection with the connector.
8. A smoking substitute apparatus according to any one of the preceding claims comprising a conduit extending between the passage and the additive inlet.
9. A smoking substitute apparatus according to claim 8 comprising a housing through which the passage extends along a longitudinal axis, the conduit extending laterally from the passage to the additive inlet, which is at an outer surface of the housing.
- 25 10. A smoking substitute apparatus according to any one of claims 1 to 5 comprising:
 - a first portion comprising the aerosol generator and a first section of the passage; and
 - a second portion comprising the additive inlet and a second section of the passage, the second
 - 30 portion removably mountable to the first portion such that the first and second sections of passage are fluidly connected, so as to define the passage.

11. A smoking substitute system comprising:
- a smoking substitute apparatus according to any one of claims 1 to 9; and
 - a receptacle comprising a cavity for containing a pressurised additive, the receptacle for connection with the smoking substitute apparatus such that the cavity is in fluid communication with the passage downstream of the aerosol generator.
- 5
12. A smoking substitute system according to claim 11 wherein the receptacle is releasably mountable to the smoking substitute apparatus.
13. A smoking substitute system according to claim 11 or 12 wherein the receptacle comprises a valve for controlling the flow of additive from the cavity.
- 10
14. A smoking substitute system according to claim 13 wherein the valve is movable from a closed position in which the additive is prevented from flowing from the cavity to an open position in which the additive is able to flow from the cavity in response to fluid flow through the passage when the receptacle is mounted to the smoking substitute apparatus.
- 15
15. A smoking substitute system according to claim 14 wherein the valve is configured to move from the closed position to the open position in response to an inhalation from the outlet by a user.
16. A smoking substitute system according to claim 15 wherein the receptacle comprises a connector for releasably connecting the receptacle to the smoking substitute apparatus.
17. A smoking substitute system according to any one of claims 11 to 16 wherein the receptacle comprises an opening for release of additive from the cavity and:
- 20
- a removable seal for sealing the opening; or
 - a frangible seal extending across the opening.
18. A smoking substitute system according to any one of claims 11 to 17 wherein the additive comprises a flavourant.
19. An additive delivery article for supplying an additive to a smoking substitute apparatus, the additive delivery article comprising:
- 25
- a cavity for containing the additive under pressure;
 - an outlet for releasing additive from the cavity;
 - a connector portion for connecting the outlet to an additive inlet of the smoking substitute article;
 - and

a valve between the cavity and the outlet, the valve configured to move from a closed position in which flow of additive from the cavity is prevented and an open position in which additive is able to flow from the cavity to the outlet in response to a drop in pressure at the outlet.

20. A flavour delivery article according to claim 19 wherein the pressure drop corresponds to a user
5 inhaling from a mouthpiece of the smoking substitute apparatus in fluid connection with the outlet of the flavour delivery article when connected thereto.

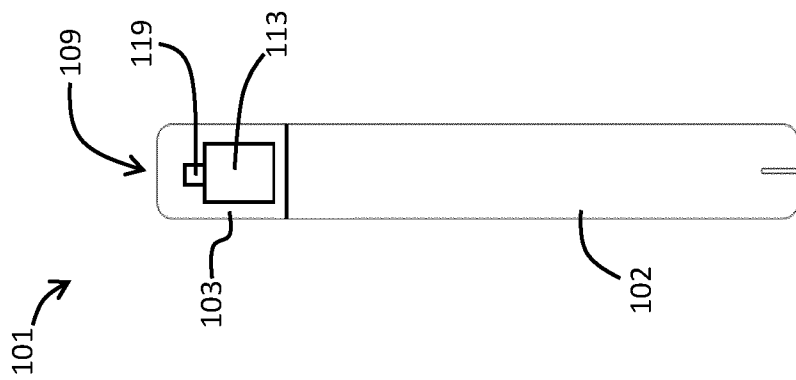
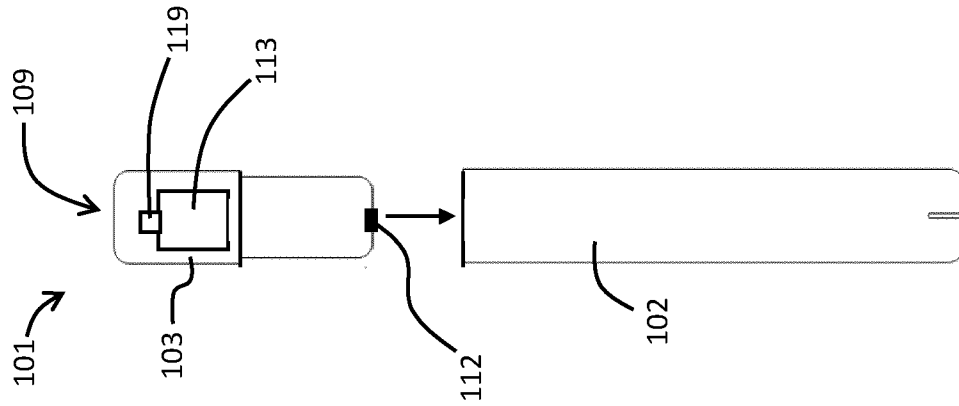

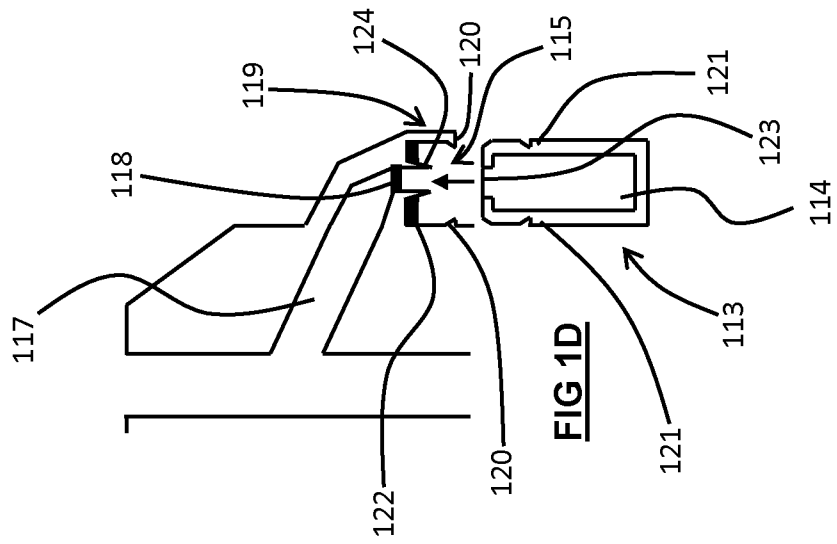
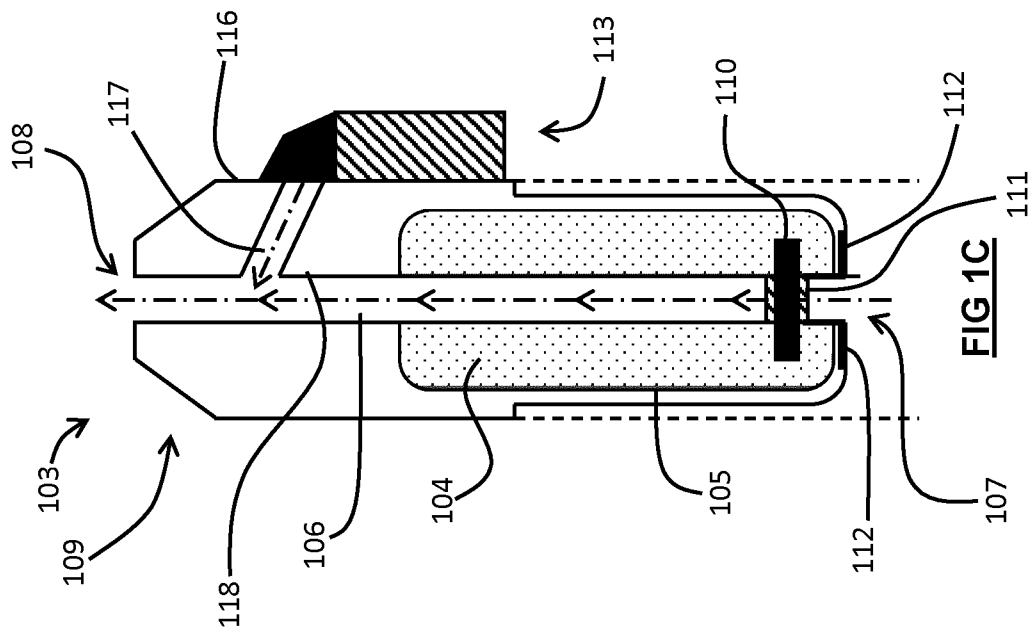

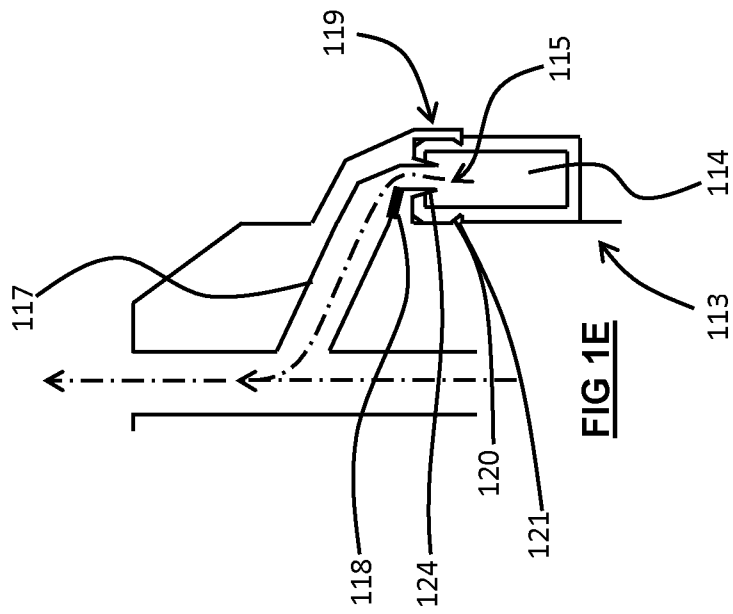
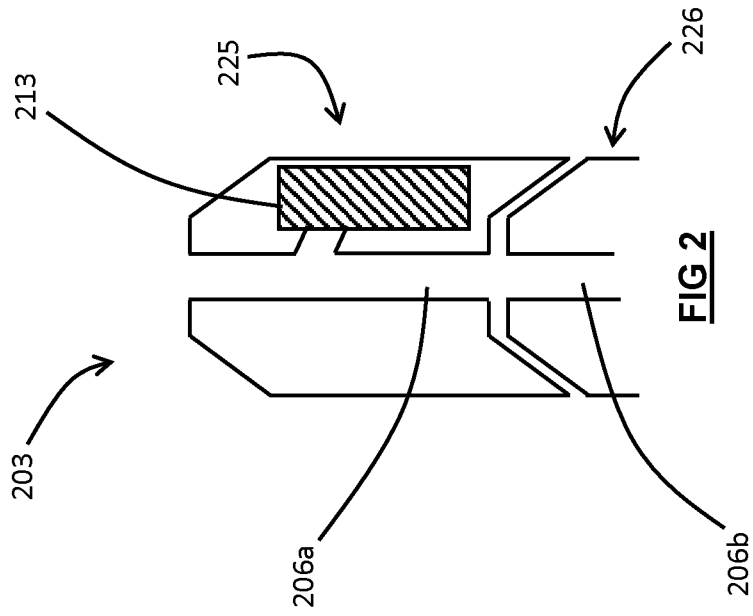

INTERNATIONAL SEARCH REPORT

International application No
PCT/EP2020/053112

A. CLASSIFICATION OF SUBJECT MATTER
INV. A24F47/00 A24F40/40 A24F42/60
ADD.
According to International Patent Classification (IPC) or to both national classification and IPC

B. FIELDS SEARCHED
Minimum documentation searched (classification system followed by classification symbols)
A24F A61M

Documentation searched other than minimum documentation to the extent that such documents are included in the fields searched

Electronic data base consulted during the international search (name of data base and, where practicable, search terms used)
EPO-Internal, WPI Data

C. DOCUMENTS CONSIDERED TO BE RELEVANT

Category*	Citation of document, with indication, where appropriate, of the relevant passages	Relevant to claim No.
A	US 2018/360110 A1 (MARSOT TRAVIS RYAN [US] ET AL) 20 December 2018 (2018-12-20) paragraph [0075] - paragraph [0082] -----	1-20
A	WO 2016/050244 A1 (FERTIN PHARMA AS [DK]) 7 April 2016 (2016-04-07) page 9, line 21 - page 20, line 30; figures 1-3 -----	1-20
A	WO 00/21598 A1 (PHILIP MORRIS INC [US]) 20 April 2000 (2000-04-20) page 16, line 15 - page 17, line 5 -----	1-20

Further documents are listed in the continuation of Box C.

See patent family annex.

* Special categories of cited documents :

"A" document defining the general state of the art which is not considered to be of particular relevance	"T" later document published after the international filing date or priority date and not in conflict with the application but cited to understand the principle or theory underlying the invention
"E" earlier application or patent but published on or after the international filing date	"X" document of particular relevance; the claimed invention cannot be considered novel or cannot be considered to involve an inventive step when the document is taken alone
"L" document which may throw doubts on priority claim(s) or which is cited to establish the publication date of another citation or other special reason (as specified)	"Y" document of particular relevance; the claimed invention cannot be considered to involve an inventive step when the document is combined with one or more other such documents, such combination being obvious to a person skilled in the art
"O" document referring to an oral disclosure, use, exhibition or other means	"&" document member of the same patent family
"P" document published prior to the international filing date but later than the priority date claimed	

Date of the actual completion of the international search 21 April 2020	Date of mailing of the international search report 04/05/2020
--	--

Name and mailing address of the ISA/ European Patent Office, P.B. 5818 Patentlaan 2 NL - 2280 HV Rijswijk Tel. (+31-70) 340-2040, Fax: (+31-70) 340-3016	Authorized officer Cardan, Cosmin
--	--

INTERNATIONAL SEARCH REPORT

Information on patent family members

International application No PCT/EP2020/053112

Patent document cited in search report	Publication date	Patent family member(s)	Publication date
US 2018360110	A1	20-12-2018	NONE
WO 2016050244	A1	07-04-2016	EP 3200631 A1 09-08-2017
			US 2017251727 A1 07-09-2017
			WO 2016050244 A1 07-04-2016
WO 0021598	A1	20-04-2000	AT 358508 T 15-04-2007
			AU 757509 B2 20-02-2003
			CA 2347536 A1 20-04-2000
			CA 2602426 A1 20-04-2000
			CN 1323231 A 21-11-2001
			DE 69935728 T2 03-04-2008
			DK 1126892 T3 20-08-2007
			EP 1126892 A1 29-08-2001
			ES 2285862 T3 16-11-2007
			IL 142169 A 18-12-2005
			JP 4166952 B2 15-10-2008
			JP 2002527153 A 27-08-2002
			JP 2008286801 A 27-11-2008
			KR 20010080091 A 22-08-2001
			NO 333225 B1 15-04-2013
			NO 337345 B1 21-03-2016
			NZ 510702 A 27-09-2002
			RU 2232032 C2 10-07-2004
			US 6234167 B1 22-05-2001
			US 6516796 B1 11-02-2003
			US 6557552 B1 06-05-2003
			US 2004050383 A1 18-03-2004
			WO 0021598 A1 20-04-2000
			ZA 200102509 B 26-06-2002