

(No Model.)

3 Sheets—Sheet 1.

P. SWENSON.
THRASHING MACHINE.

No. 525,749.

Patented Sept. 11, 1894.

Fig. 1.

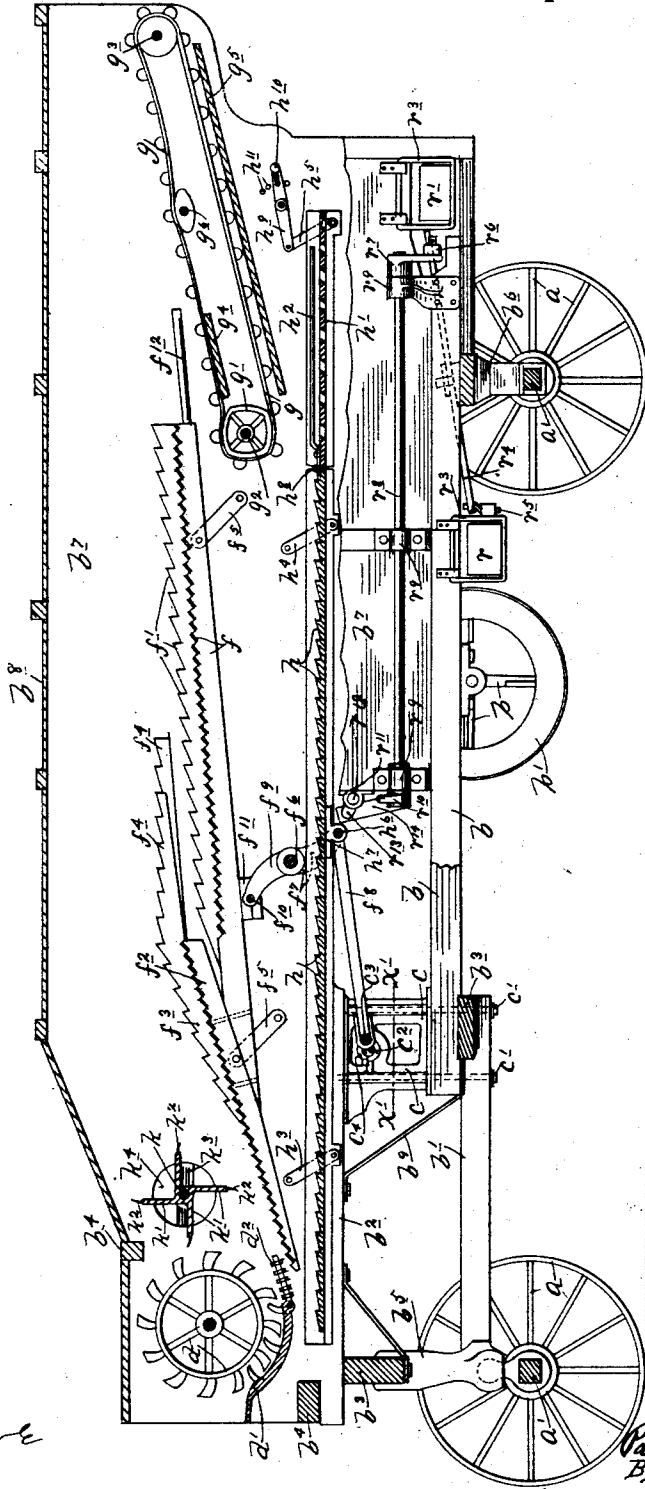

Witnesses.
E. F. Edmore

Frank D. Merchant.

Inventor.

Paul Swenson
By his Attorney,

Geo. P. Williamson

(No Model.)

3 Sheets—Sheet 2.

P. SWENSON.
THRASHING MACHINE.

No. 525,749.

Patented Sept. 11, 1894.

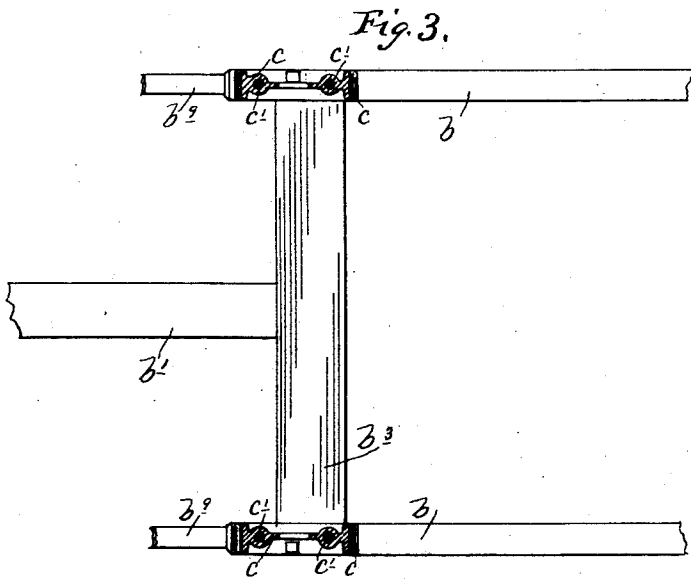
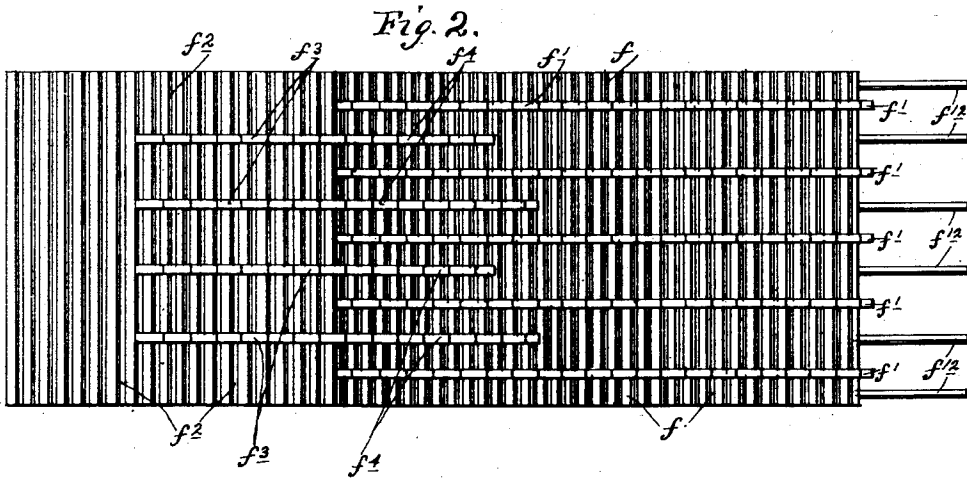

Witnesses.
E. F. Elmore,
Frank D. Merchant,

Inventor.
Paul Swenson,
By his Attorney,
Jas. P. Williamson

(No Model.)

3 Sheets—Sheet 3.

P. SWENSON.
THRASHING MACHINE.

No. 525,749.

Patented Sept. 11, 1894.

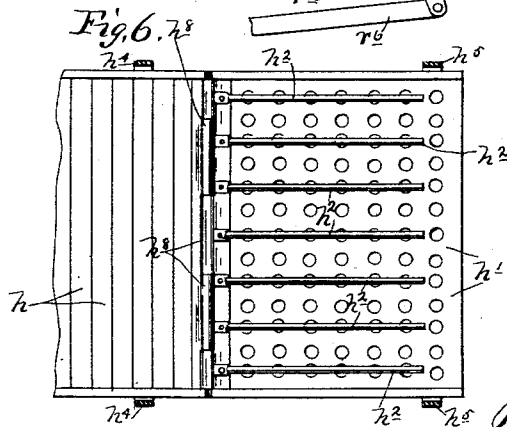
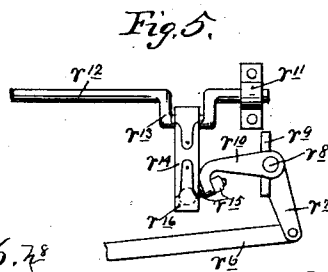
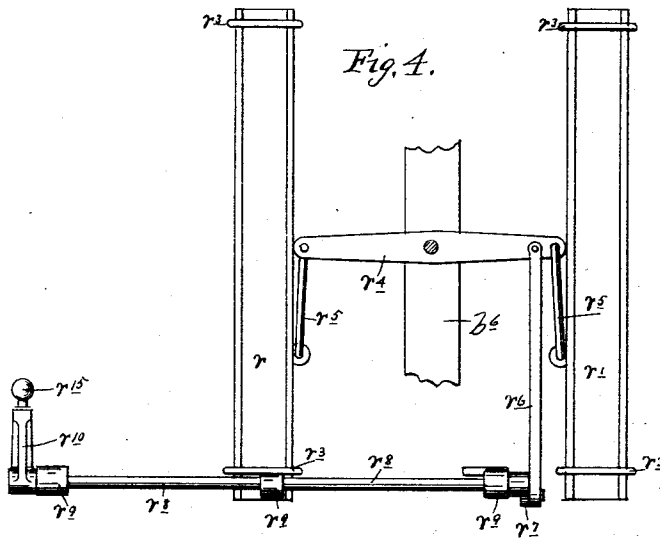

Witnesses.
E. F. Elmore
Frank D. Merchant

Inventor.
Paul Swenson
 By his attorney,
Jas. F. Williamson

UNITED STATES PATENT OFFICE.

PAUL SWENSON, OF MINNEAPOLIS, MINNESOTA.

THRASHING-MACHINE.

SPECIFICATION forming part of Letters Patent No. 525,749, dated September 11, 1894.

Application filed April 3, 1894. Serial No. 506,161. (No model.)

To all whom it may concern:

Be it known that I, PAUL SWENSON, a citizen of the United States, residing at Minneapolis, in the county of Hennepin and State of Minnesota, have invented certain new and useful Improvements in Thrashing-Machines; and I do hereby declare the following to be a full, clear, and exact description of the invention, such as will enable others skilled in the art to which it appertains to make and use the same.

My invention relates to thrashing machines, and has for its object to improve certain features of the construction, with a view of increasing the efficiency of the separating action.

To these ends, the invention consists of certain novel devices and combinations of devices, which will be hereinafter fully described and be defined in the claims.

The accompanying drawings illustrate my invention, wherein, like letters referring to like parts—

Figure 1 is a view chiefly in longitudinal vertical section, but partly in side elevation, with some parts removed and others broken away, showing my improved machine. Fig. 2 is a plan view of the separating and conveying table detached. Fig. 3 is a horizontal section through a part of the frame, on the line X' X' of Fig. 1. Fig. 4 is a skeleton view in plan, showing the relation of the delivery grain spout and the tailings spout and the devices for imparting thereto a shaking motion. Fig. 5 is a detail in front end elevation, showing the mechanism for imparting a rocking motion to the spout shaking shaft; and Fig. 6 is a plan view, showing the chaffer-board and a part of the grain-table detached.

a represents the supporting wheels and a' the axles, on which the frame of the machine is mounted. The main frame is composed of suitable longitudinal and cross timbers b b' b^2 b^3 b^4 , front and rear bolsters b^5 and b^6 , sidings b^7 and top or deck b^8 . The longitudinal bottom timbers are composed of the sections b b' , which are united to each other and to the longitudinal timbers b^2 by frame castings c and draw-bolts c' , working through passages in the said castings and timbers, and by the diagonal trussing braces b^9 . Otherwise stated, the said frame castings c serve to unite the timbers of the skeleton frame at what would be otherwise the weakest point and serve to

unite all the said parts together into a strong and rigid structure. The said castings c are also provided with half bearing boxes c^2 for a transverse crank shaft c^3 , through which motion is imparted to the separating table and some of the other parts. The said shaft c^3 is held on the half bearing c^2 by removable half boxes c^4 . These frame castings c , serving the functions noted, constitute one of the features of my improvement.

d represents the cylinder and d' d^2 the concave of the ordinary standard construction. To the rear of the cylinder and receiving therefrom is located the separating and conveying table, which is composed of the transversely slatted body section f , having the longitudinal serrated or stepped ribs f' on its face, and the receiving section f^2 set at an angle to the body section f and provided with the longitudinal serrated or stepped ribs f^3 , which are extended rearward at their upper ends, to form propelling arms f^4 , projecting over and substantially parallel with the body section f . The parts f^3 f^4 , carried by the receiving section f^2 , are laterally staggered or in alternate relation with the ribs f' , on the body section f . The separating table thus formed, is supported on the hangers f^5 and receives a vibrating motion from the crank-shaft c^3 , through a rock-shaft f^6 , having a crank-arm or arms f^7 connected by pitman f^8 with the said crank shaft c^3 , and having crank arms f^9 connecting with cross rod f^{10} , fixed to bearing lugs f^{11} , carried by said table. The body section f of the separating table is provided with rearwardly extending delivery fingers f^{12} overreaching the straw-carrier g . This straw carrier is of the ordinary construction, with the exception that the pulleys g' on its lower supporting shaft g^2 are of polygonal instead of circular form, for co-operating with the upper end roller g^3 , to drive the carrier and, at the same time, impart a shaking motion thereto. The carrier g traverses over the face of a cross board g^4 and above the underlying grain deck g^5 . It also receives a shaking motion from an ordinary cam action striker g^6 .

h is the grain-pan or table, which is mounted for vibratory motion, by means which will be hereinafter noted. The said grain-pan h terminates in a perforated chaffer board h' . Over this chaffer board, I place a series of

guard arms h^2 , supported in any suitable way and laterally spaced apart from each other, at a short distance above the top surface of the chaffer-board. These guard-arms h^2 constitute another feature of my invention. The grain pan or table h is supported by hangers h^3 h^4 h^5 , and the vibratory motion is imparted from the crank-shaft c^3 through the pitman f^8 and the cross-rod h^6 , mounted in boxes h^7 , secured to the under side of the grain-table. The chaffer-board section h' is pivoted to the body of the grain-table, as shown at h^8 ; and the rear end hanger h^5 is carried by a pivoted lever h^9 having spring latch h^{10} engageable with holes h^{11} , for setting the chaffer board, at any desired angle to the body of the table.

Directly to the rear of the thrashing cylinder and above the separating table, I place a rotary beater, which instead of being of the ordinary form, is constructed for both a beating and a fanning action; and to this end, it consists of the shaft k having fan-blades k' , with curved teeth k^2 at their outer end. The said shaft is mounted in bearings k^3 , extending across inlet openings k^4 , formed in the sidings of the frame.

p p' are respectively, the fan and fan-case, for supplying the blast to the shoe riddles (not shown) and the chaffer-board h' .

r r' are respectively, the delivery grain-spout and the tailings spout, which are supported with freedom for longitudinal shaking motion by bails r^3 , pivoted to the frame. The said spouts receive their shaking motion from a pivoted lever r^4 , with which lever, the said spouts are connected by rods r^5 . The lever r^4 is connected by rod or pitman r^6 with a crank-arm r^7 , on a rock-shaft r^8 , journaled in bearings r^9 on the main frame. This shaft r^8 extends lengthwise of the machine and at its forward end is provided with a crank-arm r^{10} . Crosswise of the machine, in bearings r^{11} , is located a constantly running shaft r^{12} , having a crank section r^{13} , to which is attached a pitman r^{14} . The crank-arm r^{10} on the rock-shaft r^8 is connected to the pitman r^{14} , on the constantly running rotary shaft r^{12} by a ball and socket joint. The ball member r^{15} , of this joint, is carried by the crank-arm r^{10} and engages with the socket-member r^{16} , formed in the side wall of the pitman r^{14} . The effect of this construction is to obtain a rocking motion on the shaft r^8 from the rotary shaft r^{12} . The ball and socket joint permits the necessary play to allow the crank arm r^{10} to move in the arc of a circle, while the pitman r^{14} has the straight line reciprocating motion. The throw or extent of the rocking motion on the arm r^{10} is of course short. This device constitutes a simple and cheap construction, for imparting the required motion to the spout rocking shaft r^8 .

All the movable parts, hereinbefore noted, would receive their motions indirectly from the cylinder d through suitable driving connections, which it has not been deemed necessary to show, for the purposes of this case.

Having regard to the action, with especial reference to the features of improvement, the serrated propelling arms f^4 on the separating table, arranged as described, serve to improve the separating action at the junction between the receiving section f^2 and the body section f' of the said table. The said arms f^4 will hold up all the long straw, while permitting the chopped up or more finely divided straw to drop directly onto the section f' ; and hence, under the vibrating motion of the table the separation will be more perfect, or complete. The advantage of constructing the beater k k' , so as to operate as a fan, in addition to its beating action, is that under the blast therefrom, the straw will be lightened up, thereby improving the separating action, and the dust will be carried backward instead of flying out forward through the mouth of the machine.

The advantage of the guards h^2 , over the chaffer-board h' , is that the chaff and short straws from the grain-pan or table h , will be raised onto the said guards and carried thereby above the face of the chaffer-board; and the blast from the fan p , will be much more effective on the materials delivered to the chaffer-board from the grain table. In other words, the guards h^2 will prevent the clogging and undue loading of the chaffer-board.

The advantage of the ball and socket construction r^{15} r^{16} , for converting the rotary motion of the shaft r^{12} into a rocking motion on the shaft r^8 , is that thereby a considerable saving is effected in the number and the cost of parts required to do this work. The advantage of the polygonal pulleys g^2 , for the straw carrier g , has already been noted.

What I claim, and desire to secure by Letters Patent of the United States, is as follows:

1. The combination with the thrashing cylinder and suitable separating and conveying mechanism receiving therefrom, of a combined fan and beater located directly to the rear of the cylinder and operating on the stock both with a beating and a fanning action and air supply passages opening to said fan through the side casing of the thrasher-frame, substantially as described.

2. In a thrashing machine, the combination with the frame timbers, of the frame castings c , and the draw bolts c' working therethrough, for securing the said parts together and reinforcing the frame, at that point, substantially as described.

3. In a thrashing machine, the combination with the frame timbers b b' b^2 , of the frame castings c , having the half bearing boxes c^2 , the draw-bolts c' working through said castings and timbers, and the shaft c^3 mounted in said half bearings and secured by the half boxes c^4 , substantially as described.

In testimony whereof I affix my signature in presence of two witnesses.

PAUL SWENSON.

Witnesses:

JAS. F. WILLIAMSON,
EMMA F. ELMORE.