

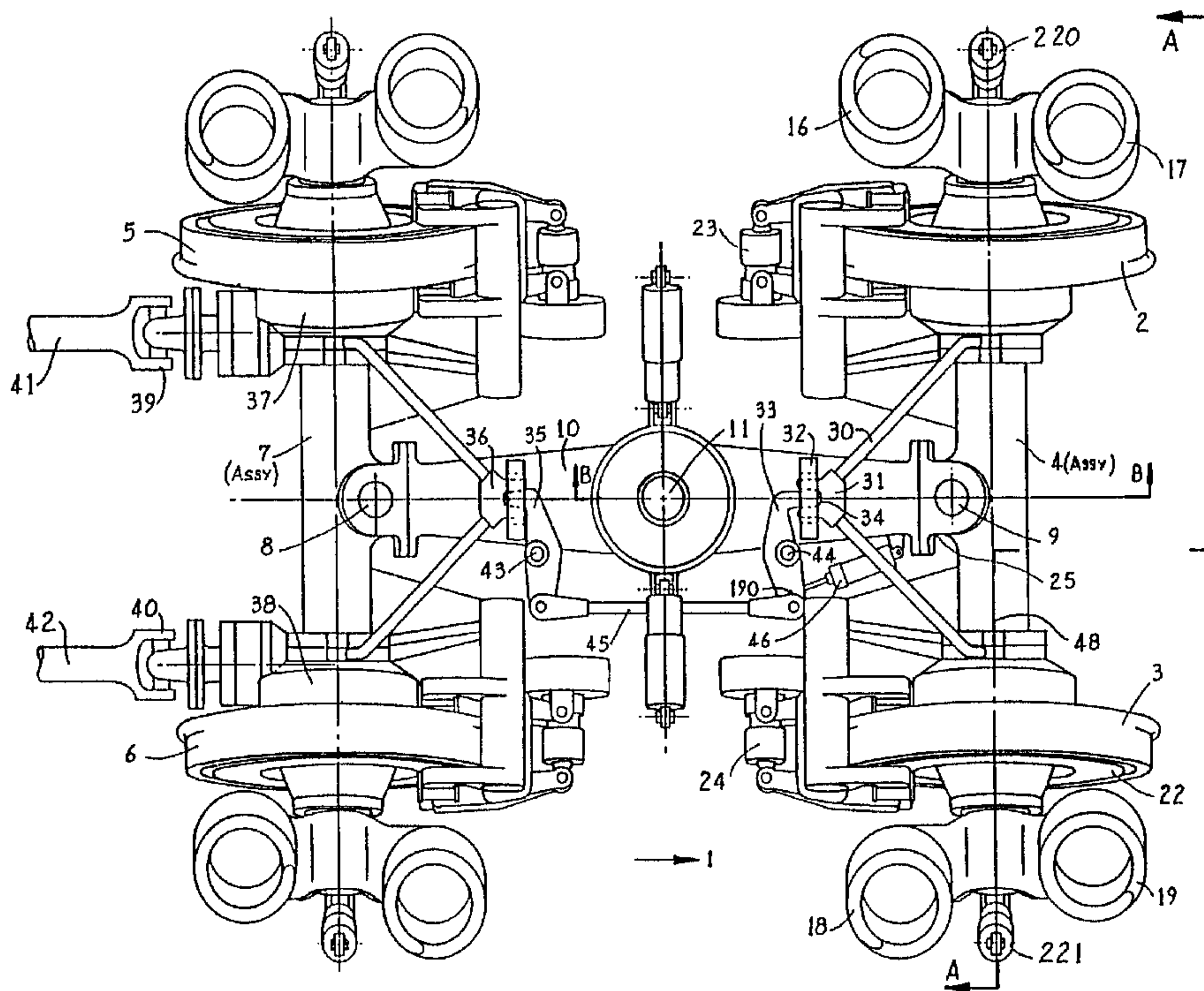

(86) Date de dépôt PCT/PCT Filing Date: 1994/02/03
 (87) Date publication PCT/PCT Publication Date: 1994/08/18
 (45) Date de délivrance/Issue Date: 2003/03/18
 (85) Entrée phase nationale/National Entry: 1995/07/25
 (86) N° demande PCT/PCT Application No.: AU 1994/000046
 (87) N° publication PCT/PCT Publication No.: 1994/018048
 (30) Priorité/Priority: 1993/02/03 (PL 7084) AU

(51) Cl.Int.⁶/Int.Cl.⁶ B61F 5/38
 (72) Inventeur/Inventor:
 BISHOP, ARTHUR ERNEST, AU
 (73) Propriétaire/Owner:
 BISHOP, ARTHUR ERNEST, AU
 (74) Agent: BROUILLETTE KOSIE PRINCE

(54) Titre : BOGIE A ESSIEUX AUTODIRECTEURS
 (54) Title: SELF-STEERING RAILWAY BOGIE



(57) Abrégé/Abstract:

A self steering railway bogie to run on a railway track having two opposed rails, the bogie having a pair of axle sets (4, 7) one at each end, each axle set having a pair of wheels (2, 3 and 5, 6) at opposite sides thereof, each wheel (2, 3, 5, 6) being, independently rotatable on an axle, the wheels of at least one axle set having contours on the periphery thereof such that, on being displaced laterally with respect to the other axle set and relative to the centre line of the track, one wheel will rise and the other will fall with respect to the wheels of said second axle set whereby said one axle set becomes tilted with respect to said second axle set, this tilt being applied to steer one or both axle sets.



INTERNATIONAL APPLICATION PUBLISHED UNDER THE PATENT COOPERATION TREATY (PCT)

<p>(51) International Patent Classification ⁵ : B61F 5/38, 5/46, 5/44, 5/50, 3/16</p>	<p>A1</p>	<p>(11) International Publication Number: WO 94/18048 (43) International Publication Date: 18 August 1994 (18.08.94)</p>
--	-----------	---

<p>(21) International Application Number: PCT/AU94/00046 (22) International Filing Date: 3 February 1994 (03.02.94) (30) Priority Data: PL 7084 3 February 1993 (03.02.93) AU (71)(72) Applicant and Inventor: BISHOP, Arthur, Ernest [AU/AU]; 21 Seaman Street, Greenwich, NSW 2065 (AU). (74) Agent: F B RICE & CO.; 28A Montague Street, Balmain, NSW 2041 (AU).</p>	<p>(81) Designated States: AT, AU, BB, BG, BR, BY, CA, CH, CN, CZ, DE, DK, ES, FI, GB, HU, JP, KP, KR, KZ, LK, LU, LV, MG, MN, MW, NL, NO, NZ, PL, PT, RO, RU, SD, SE, SK, UA, US, UZ, VN, European patent (AT, BE, CH, DE, DK, ES, FR, GB, GR, IE, IT, LU, MC, NL, PT, SE), OAPI patent (BF, BJ, CF, CG, CI, CM, GA, GN, ML, MR, NE, SN, TD, TG).</p> <p>Published <i>With international search report.</i></p> <p style="text-align: center; font-size: 2em; font-weight: bold;">2154686</p>
---	---

(54) Title: SELF-STEERING RAILWAY BOGIE

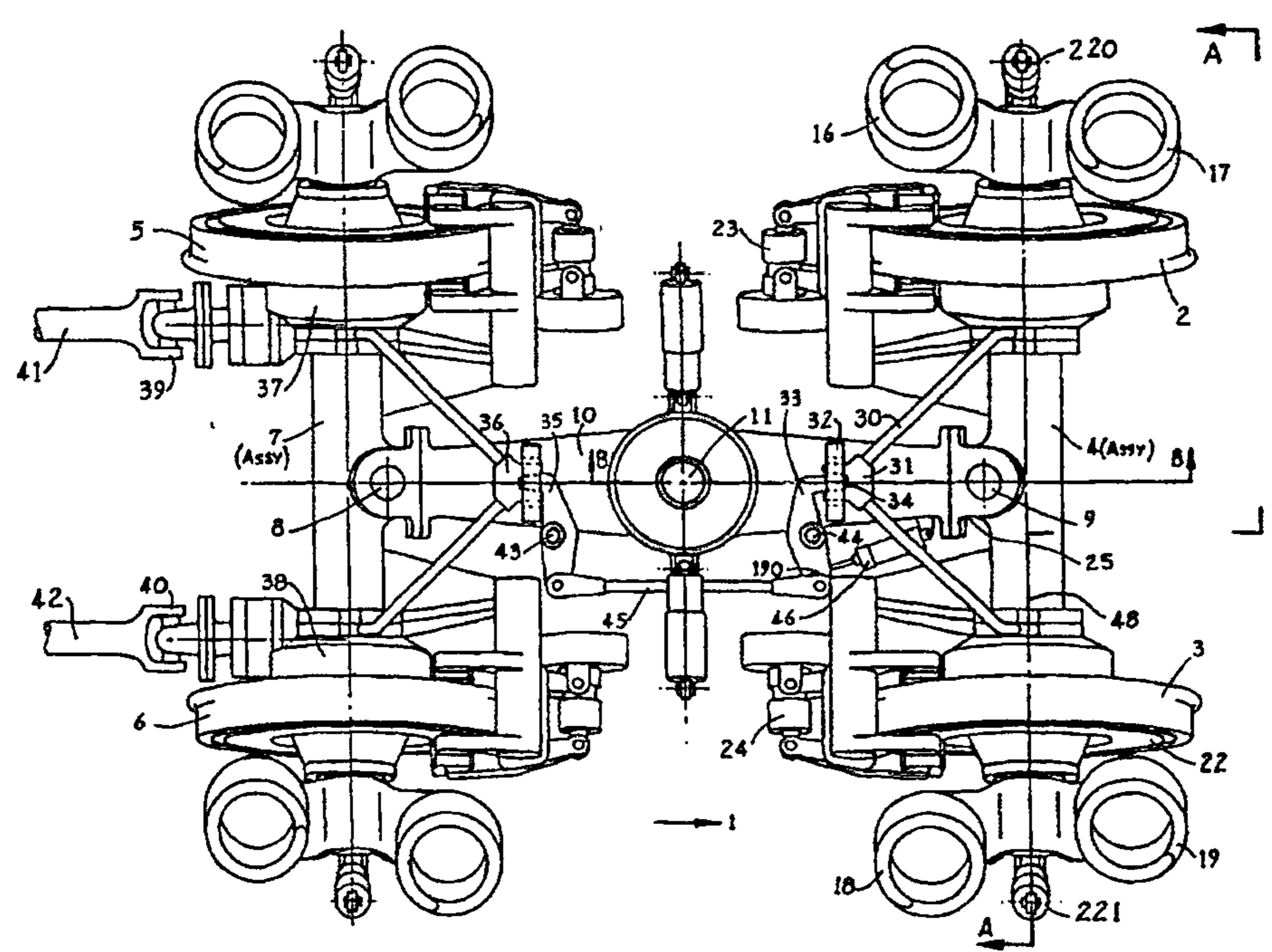

(57) Abstract

A self steering railway bogie to run on a railway track having two opposed rails, the bogie having a pair of axle sets (4, 7) one at each end, each axle set having a pair of wheels (2, 3 and 5, 6) at opposite sides thereof, each wheel (2, 3, 5, 6) being independently rotatable on an axle, the wheels of at least one axle set having contours on the periphery thereof such that, on being displaced laterally with respect to the other axle set and relative to the centre line of the track, one wheel will rise and the other will fall with respect to the wheels of said second axle set whereby said one axle set becomes tilted with respect to said second axle set, this tilt being applied to steer one or both axle sets.

Self-Steering Railway BogieTechnical Field

This invention relates to railway bogies as widely used on railways, tramways, and the like to support of a carriage or locomotive.

Background

The principle conventionally used to guide a carriage on a railway track, introduced by Stephenson in about 1830 is to employ two wheelsets each comprising an axle having a wheel rigidly attached at each end the wheels having conical running surfaces, tapered away from the middle of the axle. This arrangement is usually termed the conicity principle.

The angle of the taper is about one in twenty, and it is common practise to incline the surface of the rail heads at a similar angle to ensure adequate load distribution over the area of contact between wheel and rail. Because the wheels are solidly mounted on the axle (and not free to rotate independently as in automotive practice), any displacement of the axle from the centre line of the track causes the outboard wheel to roll on a larger diameter and the inboard wheel on a smaller diameter causing the axle to steer back to the centre of the track. In a curved section of track each wheelset takes up a position displaced outwardly from the centre of the track an amount appropriate to the degree of curvature, and provision must be made for the axles to steer so that their axes converge. This steer angle for a given radius increases with the spacing between the axles and becomes impractical for long carriages, which lead to the adoption of bogies having closely spaced axles at each end of carriages. The taper of the wheels must be great enough to allow the bogie to traverse the given track radius without undue sideways displacement but not great enough to precipitate cyclic yawing oscillations of the bogie which tend to increase in severity with speed. Such

2154686

oscillations are inherent in the conicity principle wheelset.

In recent decades, attempts to increase greatly the speed of trains has led to the adoption of special profiles and very close tolerances in the profiles of the running surfaces of the wheels which deteriorate rapidly at high speeds. Grinding techniques have been developed to regularly restore the wheel profiles and also those of the rail heads in some cases. Low cone angles reduce the tendencies of such bogies to oscillate but preclude trains equipped with such bogies negotiating curved track less than hundreds of metres in radius. However, when new railways are built, particularly in suburban environments, they often require tracks that include tight bends and also steep gradients.

Summarising, the shortcomings arising from the use of conventional bogies using the conicity guidance principle are as follows:

1. Marginal dynamic stability leading to bogie oscillations and hence poor comfort for passengers which problems increase with speed.
2. Poor performance in tight curves leading to rapid track and wheel wear, noise and the risk of derailment.
3. Reduced adhesion of wheels on the rails due to the presence of a slippage zone occurring within the contact area which is inevitable using conical wheel treads.
4. Because of the presence of this slippage, the rolling resistance of a train is substantially greater than if, for example, cylindrical wheels are used.
5. Restricted ability to negotiate very tight curves, which in urban areas makes new railway installations more expensive due the cost of land resumptions or tunnelling.

Many attempts have been made to overcome the problems of conicity-based wheelsets with limited success, and designers are turning to bogies having four independent wheels for a solution, for example, UK Patent 1,496,190 by Arthur Seifert entitled A Truck for a Railway Vehicle discloses a pair of independently rotating wheels for a railway bogie, the wheels
5 secured to rotating axles which are downwardly inclined between 5° and 45°. The arrangement is intended to operate on conventional tracks having substantially flat rail heads and it follows that the wheel running faces comprise steep cones with their apexes in board of the wheel. This arrangement claims to provide less flange wear and friction and improved distribution of wheel loads to the bearings of the axles. However, such an arrangement would
10 inevitably increase the frictional drag and wear of the main load carrying load contact area between the wheels and rails. No steering of the wheels is possible with Seifert's arrangement.

In particular the present invention in one aspect provides a railway bogie adapted to run on a railway track having two rails laterally offset about a track centre line, the bogie comprising a
15 pair of axle sets one at each end, each axle set having two mutually opposite independently rotating wheels, characterized in that the railway bogie is a self steering railway bogie, each of the wheels of at least one axle set has a peripheral profile adapted to engage one of said rails respectively such that, on being displaced laterally with respect to the other axle set and relative to said track centre line, one wheel will rise and the other will fall with respect to the
20 wheels of the other axle set whereby said at least one axle set undergoes a tilt change with respect to said other axle set and means responsive to said tilt change to steer one or both axle sets.

In accordance with the present invention each wheel may have an axle whose axis may be
25 inclined downwardly towards said track centre line and said peripheral profile where it contacts said track may also be downwardly inclined towards said track centre line wherein said means responsive to said tilt change of one of said axle sets with respect to the other axle set may be connected by a linkage to the axles and may be arranged so as to steer each said axle set so that each wheel of the set substantially aligns with the centre line of the respective
30 rail beneath it.

In accordance with the present invention said peripheral profile may be cylindrical.

5 In accordance with the present invention lines passing through contact faces between the wheels and the rails and normal thereto may intersect at a height at least substantially equal to the height of the centre of gravity of the bogie and any carriage supported thereby.

10 In accordance with the present invention lines passing through contact faces between the wheels and the rails and normal thereto may intersect at a height substantially higher than the centre of gravity of the bogie and any carriage supported thereby.

In accordance with the present invention at least one of said axle sets may be pivotal about an axis located at the mid plane of the axle set and inclined to the vertical in the direction of the centre line of the track.

15 In accordance with the present invention both axle sets may be pivotable about an axis located at the mid plane of the axle set and inclined to the vertical, means being provided to fix either axle set against rotation about its axis.

20 In accordance with the present invention each wheel axle may be individually pivoted about a steering axis, the steering axes of each pair of wheels being disposed on opposite ends of the respective axle set, the pivots of the wheel axles of each pair on the same side of the bogie being interconnected by a longitudinally extending side frame member, the side frame members being relatively rotatable about a common axis transverse to the bogie, said rotation caused by a relative rise of two diagonally opposite wheels, a steering transfer box responsive
25 to said rotation being connected to linkage means arranged to steer at least one pair of wheel axles.

30 In accordance with the present invention said peripheral profile of each of the wheels of said at least one axle set may be inclined downwardly towards said track centre line whereby lateral offset of said axle set with respect to said track centre line produces a component of rotation of this axle set about a horizontal axis parallel with said track centre line, wherein the

bogie may also comprise steering means for said at least one axle set said steering means comprising a linkage means between said pair of axle sets, said linkage means being arranged such that said component of rotation also produces relative rotation of said pair of axle sets, thereby steering one axle set with respect to the other axle set and maintaining the lateral position of the bogie with respect to said track centre line.

In accordance with the present invention said linkage means may comprise an instantaneous steering axis between said pair of axle set which is inclined with respect to the vertical and arranged such that said component of rotation also produces relative rotation of said pair of axle sets about said instantaneous steering axis.

In accordance with the present invention said linkage means may comprise an instantaneous steering axis between at least one axle set and the bogie which is inclined with respect to the vertical and arranged such that said component of rotation also produces relative rotation of said at least one axle set with respect to the bogie about said instantaneous steering axis.

In accordance with the present invention said bogie may comprise a pair of longitudinal side frame members one at each side, each side frame member comprising two independently rotating wheels each of which belongs to a respective one of said pair of axle sets, said wheels of each side frame member being located at opposite ends of said bogie and being adapted to engage the same rail said peripheral profile of at least one wheel of each side frame member being inclined downwardly towards said track centre line whereby a difference between the lateral offset of said wheels of either side frame member with respect to the same rail produces a rise of one wheel with respect the other and hence a component of rotation of said respective side frame member about a horizontal axis perpendicular to said track centre line, wherein at least one wheel of each said side frame member is pivoted about a respective steering axis, and linkage means is provided to steer said at least one wheel about its steering axis as a function of said component of rotation of its respective side frame member, thereby maintaining the lateral position of the bogie with respect to said track centre line.

In accordance with the present invention the wheels at the front end of each side frame

member may be pivoted about respective steering axes and interconnected by a transverse tie rod, causing the steering applied to one front wheel of the bogie to be imparted to the other front wheel.

5 In accordance with the present invention the wheels at the rear end of each side frame member may be pivoted about respective steering axes and interconnected by a transverse tie rod, causing the steering applied to one rear wheel of the bogie to be imparted to the other rear wheel.

10 The object of the present invention is to overcome or minimise the disadvantages of the prior art railway bogies, such as inadequate dynamic stability, poor performance in tight curves which leads to track and wheel wear; and slippage between wheels and track which restricts the ability to climb substantial grades and results in a greater rolling resistance.

15 The present invention achieves the above object by providing a steerable railway bogie having independently rotatable wheels in which the bogie senses the curvature or deviation in the track upon which it runs, the bogie and track configuration being such that a relative twist occurs between front and rear axle sets and that the wheels of the bogie are steered to align themselves with their respective rails.

20 The steerable railway bogie of the present invention allows for tracks having a tighter curvature and steeper grades to be used which are particularly important in main

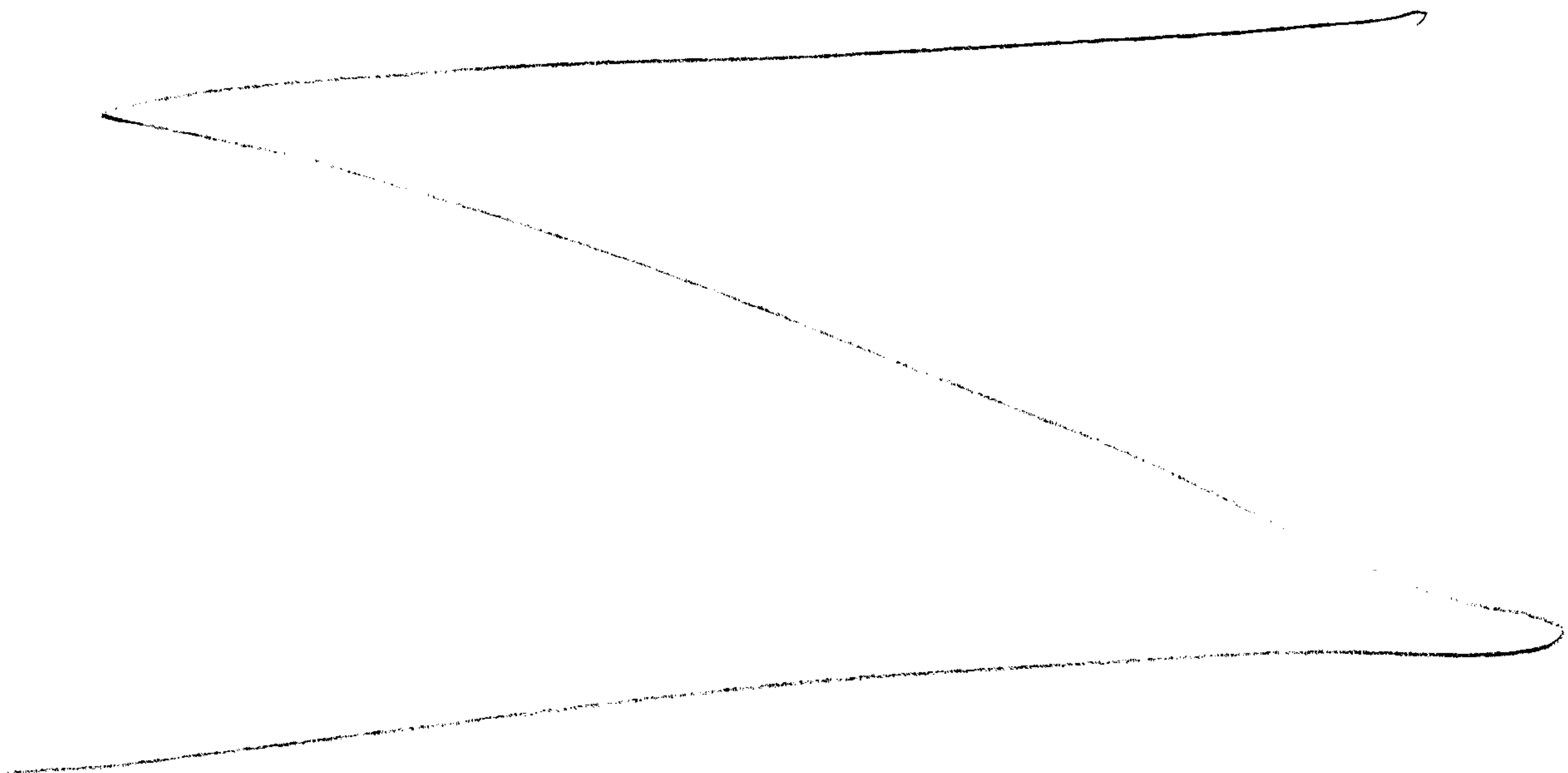

2154686

line railways but also in personal rapid transit and light rail systems.

In describing the railway bogie of the present invention which employs independently rotatable wheels, each pair of opposite wheels and their associated axles will be referred to as an axle set, and a "virtual axle" will be said to exist between the pair of wheels defined by the points where the axes of the wheel axles intersect the mid-planes of the wheels. These mid-planes are defined as the planes normal to the wheel axes which include the contact points between the wheels and the rails on a straight track.

In a curve, the front axle always initially runs outwardly of the centre of the track and the rear axle inwardly of the centre of the track that is, towards the centre of curvature of the track, and hence, because of the inclination of the wheel axles, one axle will be tilted relative to the horizontal plane in opposite direction to the other.

The essence of the invention lies in using this relative tilt to steer one or both axles in a turn to converge on the centre of turn, until a steady state yaw of the bogie to the track is achieved. It follows that the longitudinal axis of the bogie at the mid-point between the axle sets will always lie at an angle to the tangent to the curve of that point.

Similarly, when the bogie is momentarily deflected due to track deviation or disturbing forces whether on a straight or curved section, a momentary tilt or change of tilt between the front and rear virtual axles will restore the bogie to its true course relative to the track. This relative tilting of the virtual axles is therefore used, according to the invention, as a true source of track direction, ignoring small, transient perturbations of track roll which cause only momentary steer inputs which are negated as the bogie traverses the length along the

2154686

5

track equal to its wheelbase. Such selectivity can be aided by damping means on the steering of the wheels so that the bogie responds in steer principally to the intended course or heading.

5 The present invention consists in a self steering railway bogie to run on a railway track having two opposed rails, the bogie having a pair of axle sets one at each end, each axle set having a pair of wheels at opposite sides thereof, each wheel being independently rotatable on
10 an axle, the wheels of at least one axle set having contours on the periphery thereof such that, on being displaced laterally with respect to the other axle set and relative to the centre line of the track, one wheel will rise and the other will fall with respect to the wheels of
15 said second axle set whereby said one axle set becomes tilted with respect to said second axle set and means responsive to said tilt to steer one or both axle sets.

 Preferably each wheel has an axle whose axis is inclined downwardly toward the centre of the track, and a
20 contour on its periphery where it contacts said track also downwardly inclined toward the centre of the track, wherein said means responsive to said tilt of one of said axle sets with respect to the other axle set is connected by a linkage to the axles and is constructed and arranged
25 so as to steer each said axle set so that each wheel of the set tends to align with the centre line of the respective rail beneath it.

 The nature of the invention, the consideration leading to its development and a number of embodiments
30 according to the invention are hereinafter described by way of example with reference to the accompanying drawings, which are briefly described below.

DESCRIPTION OF THE DRAWINGS

 Fig. 1. Plan view of a bogie made according to a
35 first embodiment of the invention.

2154686

6

Fig. 2. End elevation of the bogie of Fig. 1 with a part section of view along line AA.

Fig. 3. Side elevation of the bogie in Fig. 1.

Fig. 4. Sectional elevation on line BB of Fig. 1.

5 Fig. 5. Diagrammatic front view of an axle set according to the first embodiment of the invention but also applicable to the second embodiment of the invention. Fig. 5a Partial enlarged sectional view of the area encircled in Fig. 5.

10 Fig. 5b. Section along the line CC of Fig. 5a.

Fig. 6. Diagrammatic plan view of the first embodiment of the invention in a turn.

Fig. 7. Diagrammatic superimposed elevations of the front and rear axle sets of Fig. 6.

15 Fig. 8. Plan view of the second embodiment of the invention.

Fig. 9. Elevation of the bogie part sectioned on line DD of Fig. 8.

20 Fig. 10. Side elevation of the bogie shown in Fig. 8.

Fig. 11. Schematic view of a bogie made according to the second embodiment of the invention.

Fig. 12 Sectional view of the steering transfer box on line EE of Fig. 8.

25 Fig. 13. Plan sectional view on line FF of Fig. 11

Fig. 14. Sectional elevation on line GG of Fig. 12.

Fig. 15. Diagrammatic view of a pivotal axle set along the direction of a curve (curve tangent view).

Fig. 16. Diagrammatic bogie plan (top view).

30 Fig. 17. Diagrammatic bogie elevation (side view).

Fig. 18. Diagrammatic view of the pivotal axle set along the pivot line (pivot view).

Fig. 19. Diagrammatic bogie elevation in the straight-ahead position (side view).

35 Fig. 20. Diagrammatic view of the pivotal axle set along the direction V (front view).

2154686

Fig. 21. Diagrammatic expanded detailed construction of Fig. 15.

Mode for Carrying Out the Invention

Figs. 1 to 4 show views of a bogie as applied to mainline railways made according to a first embodiment of the invention. The bogie may be set to operate in either direction and, as shown, operates to the right, arrow 1. Wheels 2 & 3 form part of first axle assembly 4, and wheels 5 & 6 form part of second axle assembly 7.

Axle assemblies 4 & 7 are pivoted at 9 & 8 to longitudinal beam 10, which itself is pivoted at centre point 11 to pillar 12 attached to the underside of carriage 13 (partially shown). Centre pivot 11 incorporates rubber damping bushes and serves to transmit lateral and longitudinal forces between the bogie and carriage 13 but is such as to allow free vertical movement there between.

During operation of the bogie in direction 1 pivot 8 on second axle assembly 7 is locked as will be described later so that axle assembly 7 and longitudinal beam 10 acts as one integral member.

Axle assembly 4 (Figure 2) comprise wheels 2 & 3 which are journalled on stub axles 14 & 15 which are bolted to opposite ends of crossbeam 47 and extend outwardly to provide mountings for springs 16, 17, 18 & 19 and shock absorbers 220 & 221, attached to the underside of carriage 13 to allow the bogie to swivel in curves. Stub axles 14 & 15 have their axes 48 & 49 downwardly inclined towards the centre of the bogie. Wheels 2 & 3 are provided with brake disks 22 (sectional view, figure 2) and brake assemblies 23 & 24.

A first pivot assembly 25, (Figure 4) is located at pivot 9 and comprises brackets 26, attached to longitudinal beam 10, journals 27 and pivot pin 28, which is carried in crossbeam 47. Pivot pin 28 is shown inclined to the vertical at some small angle 29. In other

2154686

not shown embodiments this angle 29 may be large. Journals 27 incorporate resilient material and are arranged to allow some axial movement on pivot pin 28 but are substantially rigid in the radial directions.

5 Axle assembly 4 carries brace 30 incorporating escapement member 31 which serves both to limit the maximum angular rotation of axle assembly 4 with respect to longitudinal beam 10 by abutments provided in bridge member 32, and to prevent any rotation of axle assembly 4
10 about pivot 9, upon operation of latch 33. As shown in Fig. 1, latch 33 is disengaged from notch 34 provided in escapement member 31 so permitting axle assembly 4 to pivot about pivot 9 through some small angle typically around 2 degrees. Latches 33 & 35 are pivoted about pins
15 44 & 43 carried on longitudinal beam 10 and are coupled at their outer ends by link 45. Air cylinder 46 pivoted to beam 10 is connected to latch 33 by pin 190 and acts to engage and disengage latches 33 & 35 alternatively depending upon the direction of travel of the bogie. In
20 further not shown embodiments other means of operating these latches can be used.

All aspects of second axle assembly 7 are identical to those just described in respect to first axle assembly 4, except that latch 35, is as shown, engaged in
25 escapement member 36 whereas latch member 33 is as shown disengaged from escapement member 31. It should be noted that if the direction of the bogie was to be reversed ie. in the direction opposite to arrow 1, then latch 33 would be engaged and latch 35 would be disengaged.

30 In the description of operation of a bogie the first axle set assembly will from now be termed the front axle assembly when operating in the direction shown in Fig. 1 and the second axle set will be the rear axle set.

Axle assembly 7 is shown provided with independent
35 spiral bevel gear drives 37 & 38 to wheels 5 & 6 and are driven by flexible couplings 39 & 40 from drive shafts 41

2154686

& 42 connected to motors (not shown) mounted underneath carriage 13. This method of driving independently rotating wheels is well-known in the art.

5 The manner in which the bogie is steered will now be described with reference to Figs 5, 6 & 7.

Figure 5 shows the first axle assembly travelling on rails 50 & 51, which are supported on sleeper 52 by angled supports 53 & 54 at equal angles 55 to the horizontal, matching the inclination of axes 48 & 49 of stubaxles 14 & 15. Lines 58 & 59 drawn through the centre of the heads of rails 50 & 51 and the mid-plane of wheels 3 & 2 at equal angles 55 to the vertical, will intersect on the centreline plane 56 of carriage 13, axle assembly 4 and rails 50 & 51 at point 60. For convenience, axle assembly 15 4 may be referred to as a virtual axle 69, being a line joining the intersection of stub axle axes 48 & 49 with the mid-planes of wheels 3 & 2 coincident with lines 58 and 59 respectively. The corresponding virtual axle in the case of second axle assembly 7 will be referred to as 20 virtual axle 70.

It is evident that, if the carriage and bogies, having a longitudinal centre of gravity axis 61 are subject to a horizontal force 57, acting at the centre of gravity, for example, a centrifugal force in a turn, or a 25 lateral inertial reaction force due to track deviation, and points 60 & 61 are coincident, then no rolling tendency will be imparted to the carriage and bogie. Such forces merely increase or decrease the normal forces 62 & 63 acting at the contact between wheels and rails. In a 30 similar situation, with conventional bogies using the conicity principle, such side forces are resisted by lateral rolling frictional forces, and frequently by contact equivalent to contact here between wheel flanges 64 & 65 with the sides of rails 50 & 51. However, it is 35 not necessary to make intersection point 60 as low as the

2154686

10

centre of gravity 61 in order to gain many of the benefits of the inclined wheel axis geometry.

A further advantage relates to the nature of the contact between the wheels and rails. When the wheels are substantially cylindrical and the railheads substantially flat the contact zones are large and essentially rectangular. There is no element of sliding contact during rolling, which inevitably occurs when a conical wheel is constrained to roll in a straight line as happens in conventional conicity-principle wheelsets, the elimination of which substantially increases the gripping force between the wheels and the rails. The angled orientation to the horizontal increases the normal force and further increases the gripping force. The elimination of the sliding component which is present at all times, substantially reduces the rolling resistance of the carriage.

Furthermore, in the event of flange contact occurring, there is less tendency to lift the wheel and hence de-rail than occurs with the standard rail and wheel geometry. As shown in partial Figs. 5a & 5b the face of flange 64 of wheel 3 is nearly vertical in the contact zone and, being conical, contact will occur in the vertical plane XX which lies directly below the stub axle axis 48 avoiding the shearing element of flange contact present in standard rail geometry. Instead, if flange contact occurs, the tangential component of the contact force acts at a larger radius than the rolling radius of the wheel. This factor is important in overcoming what might be seen as a disadvantage of the pivoted beam front axle, namely, the tendency for the axle to be deflected to the limits (eg. 2 degrees) by, say, an obstruction on the rail. The flange contact thus provides the necessary restoring force, in this event, to realign the axle with the direction of the track. This restoring force, which is present but to a lesser degree in conventional wheel

2154686

sets is far less effective under the same circumstances because of the rigid connections between the wheels, whereas the restoring force is highly effective in the case of independent wheels

5 Figure 6 shows a plan view of the bogie when traversing a curved section of track having centreline 66, and centre of turn 67. As mentioned earlier, when a bogie is travelling in the direction 1, the rear axle assembly 7 is maintained by latch 35 (Fig.1) in a central position
10 with respect to longitudinal beam 10 and hence is here shown as a single member, whereas front axle assembly 4 is free to swivel under the action of steering forces produced by inclined pivot 9.

On entering such a turn, front wheels 2 & 3 will tend
15 to continue in a straight line and hence axle assembly 4 will move outwardly and rear axle assembly 7 will move inwardly of track centreline 66, until the stable orientation of the bogie shown in Fig. 6 is reached. The spacing of rails 50 & 51 is slightly increased in curves
20 if necessary to allow for the angled orientation of the bogie.

In Fig. 7 front wheels 2 & 3 are shown relative to rear wheels 5 & 6 as viewed along their respective sections of track shown in Fig. 6, the views being
25 superimposed with respect to centreline 56.

The mid-points of virtual axles 69 & 70 are shown as 71 & 72 and lie respectively outside and inside of track centreline 56.

Having entered the turn an angle of twist 73 will
30 occur between the front and rear axle assemblies of the bogie which must be accommodated by rotation of the front axle assembly 4 with respect to rear axle assembly 7 through an angle 74 (Fig. 6).

The necessary inclination angle 29 to the vertical,
35 of pivot 9 (Fig. 4) is calculated as described later in the specification and is such that twist angle 73 produces

2154686

rotation 74, termed the steer angle, and that the axes of virtual axles 69 & 70 converge, in plan view, on centre of turn 67.

The first embodiment of the invention is also
5 suitable, for example, to the bogies of small, automated
vehicles, such as in light rail systems, where it is
important that very sharp curves can be negotiated and, at
the same time, that the noise associated with flange
contact of steel wheels on steel rails in curves be
10 avoided.

Generally such small vehicles only require to be
operated in one direction. As the vehicles are light,
each bogie need only have one pair of load-carrying
wheels, being the front axle assembly and this may
15 incorporate a differential which is driven through
universal joints from an electric motor mounted on the
underside of the carriage. The brake is also mounted on a
motor, so that any slewing action originating in a
difference in the driving or braking torque applied to
20 opposing wheels is avoided.

The front axle assembly is pivoted directly to the
underside of the carriage through a vertically sprung
pivot. A frame pivoted on an inclined axis to the front
axle assembly carries two small inclined wheels also
25 engaging the track which provide the steering signal to
the front wheels in a manner similar to that described in
the first embodiment.

In a second embodiment of the invention, illustrated
in Figs. 8 to 14, a totally different mechanism is used,
30 notwithstanding that the system operates in substantially
the same manner as that described in embodiment 1 and is
principally suitable for mainline railways.

This second embodiment provides for a lower unsprung
mass than in the case of the earlier embodiment and
35 although the mechanism is more complicated it is probably
better adapted to the use in high speed trains. In this

embodiment all four wheels are steered independently rather than by virtue of being mounted as pairs on front and rear axle beams. As in the case of the first embodiment, the bogie may be operated in either direction and, as shown in Figure 8, operates to the right, in the direction Arrow 1. Wheels 281, 282, 283 & 284 are all journalled on stubaxles as shown in section in respect to wheel 282 in Fig. 9 and have corresponding axes of their respective stubaxles and wheel journals numbered 285, 286, 287 & 288 respectively. All wheels and axles are identical (except for right and left handedness) and the following description in relating to wheel 282 and its associated stubaxle 89 is typical of all four wheels.

Considering the front axle arrangement as shown in Fig. 9 it will be seen that the axes 285 & 286 correspond to the axes 49 & 48 of Figs. 2 & 5.

The planes 93 & 94 of wheels 282 and 281 passing through the centreline of rails 91 & 92 in the straight ahead running position as shown in Fig. 9 correspond to lines 58 & 59 in Fig 5, and intersect the respective axes 286 and 285 at points 93a & 94a. Line 95a, joining these points, becomes the "virtual axle" corresponding to the virtual axle 69 of Fig 5.

Front stubaxle 89 extends outwardly to house vertical pivot pin 96, an arrangement as that used for steering some automobiles commonly termed as king pin steering.

Preferably the axes of pin 96 extends downwardly to intersect the head of rail 91 at the centre of its area of contact with wheel 82.

By this means the geometry, as is well-known in automotive practice, reduces to an absolute minimum the forces required to steer the wheels, or the forces which can be transmitted by obstructions to the wheels.

Pivot pin 96 is journalled in resilient bushes 97 & 98 to side frame member 99 which is extended as at 100 & 101 to provide housings for bushes 97 & 98. Pivot pin 96

has an enlarged tapered head to transmit vertical force as well as lateral forces through resilient bush 97 to side frame extension 100.

5 Stub axle 89 is provided with attachment mountings for a caliper disc brake 106 similar to that shown in Fig. 1, except that the caliper pivots with stub axle 89 rather than axle assembly 4 (Fig. 1).

10 Stub axle 89 also provides inner and outer attachments 102 & 103 for steering arm 104a which serves to steer wheel 282 about the axis 96a of pivot pin 96. Steering arm 104a carries a tie rod ball joint 107 which provides a connection for tie rod 108a similarly attached to steering arm 105a associated with wheel 281. It will be seen that a line 180 passing through axis 96a of pivot
15 pin 96 and the axis of ball joint 107 intersects the centreline 109 of the bogie at a line joining the axes 96b and 96c of the pivot pins associated with wheels 284 & 283 respectively, all of which is similar to the widely-used automotive steering geometry referred to as the Ackermann geometry. This arrangement assures that, in curves, the
20 axes of all wheels will intersect at the same point just as occurs with the beam axle steering arrangement as in Fig. 1.

Shock absorbers 110 may be provided to damped
25 unwanted pivotal movements of wheels 281, 282, 283 & 284.

Steering arm 104a has an extension member 111a which enters steering transfer box 112, and correspondingly steering arm 104b associated with wheel 284 has a corresponding extension member 111b. All four wheels are
30 therefore controlled through tie rods 108a & 108b and their extension arms 111a & 111b by steering transfer box 112 in the manner to be described.

By comparing Fig. 2, the front elevation of the first embodiment of the invention with Fig. 9, a corresponding
35 view of the second embodiment, it is evident that stub axles axes 48 & 49 correspond exactly to stubaxles 285 &

2154686

286, wheels 2 & 3 correspond to wheels 281 & 282 and virtual axle 69 corresponds to virtual axle 95a.

Hence in a given curve, the relative angular inclination 73 of the front and rear virtual axles will be identical in the case of the second embodiment, given that the wheelbase track and other features of the two bogies is identical.

Now in the first embodiment, this relative angular inclination is used to steer the front axle assembly 4 by virtue of inclination of pivot 9.

The manner in which the same relative inclination of the virtual axles is used to steer the bogie in the second embodiment is shown in Fig. 11, where it is apparent that virtual axis 95a rotates counterclockwise when viewing from the front of the bogie about longitudinal axis 109 whereas virtual axis 95b rotates clockwise, this being the result of the rise of wheels 281 & 284 and the fall of wheels 282 & 283 on the sloping heads of rails 91 & 92 due to the slewing of the bogie, as described in respect to the first embodiment. Thus side frame member 99 will be rotated clockwise with respect to side frame member 113 when viewing from the right.

Side frame member 113 is formed integrally with cross frame member 114 which extends laterally across the bogie and has the bolted extension 114a which extends through side frame member 99 and is journalled thereto as shown in Figure 12.

Steering transfer box 112 is secured to side frame member 99 and pillar 115 is integrated with cross frame member 114, so that relative rotation will occur therebetween, as shown as angle 116. Angle 116 will have a magnitude equal to the relative angular rotation of virtual axes 95a & 95b (which is the same as angle 73 of the first embodiment Fig 7) multiplied by the track width divided by the wheelbase of the bogie.

2154686

16

Cross member 114 incorporates pivot 11a which is the counterpart of pivot 11 shown in Figs. 1 & 4 of the first embodiment and serves to transfer lateral and longitudinal forces from the bogie to the pillar 12a secured to the underside of carriage 13a (Fig. 9). Figs 12, 13 & 14 show views of the steering transfer box, whose function is to respond to the relative rotation of side frame members 99 & 113 as indicated by the angle 116 (Fig. 11) and steer front wheels 281 & 282, through the appropriate angles to converge on the centre of turn of the track. Referring to Fig. 14, extension members 111a & 111b extend into steering transfer box 112 through sealed openings therein, the openings being provided with abutments 181 (four places) which limit the travel of the steering arms to about 1 1/2 degrees each way even under extreme load conditions.

The steering extension members 111a and 111b are provided with open ended slots 117a & 117b which have slightly tapered faces top and bottom so as to engage in a slack-free manner slightly conical integral pins 118a & 118b of bell crank lever 119 and also, in alternate position pins 120a & 120b, also slightly conical, fixed in steering transfer block 112.

As illustrated in Fig. 14 the bogie is moving to the right so that front steering arm 104a is operable whereas steering arm 104b is locked as in the case of the beam axle arrangement of the first embodiment.

The required raising and lowering of extension members 111a and 111b is accomplished by a rocking lever 183 which operates riser pins 184a and 184b to lift the respective extension members in opposition to spring loaded plungers 121a & 121b and is operated by air cylinder (not shown).

Bell crank 119 is pivoted on pin 122 and extends to house spherical ball joint 123 in which slides the cylindrical lower end of lever extension 185 secured to

2154686
174613086

overload release lever 124 journalled on pin 125 in crosshead 126.

Crosshead 126 is fitted closely in the bore of the cylindrical vertical extension of steering transfer box 112 and is forced downwardly by a helical spring 127, so forcing overload relief lever 124 and its detent tooth 128 into forceful engagement with a detent notch 129 provided in the extended end of pin 130 secured to pillar 115.

Now distance 131 between pins 125 & 130 is chosen, in relation to distance 132 between pin 125 and the axis 186 of crossmember 114 is chosen so that the slight difference in angle of rotation of the side members 99 & 113, shown as angle 116 in Fig. 11, is amplified, typically by a factor of ten to obtain the angular rotation of lever 185. The object of this arrangement is to amplify the slight difference of angle 116 which in general will not exceed plus or minus one degree without significant loss and to this end all journals are fitted in a slack-free manner.

Such close fitting would deteriorate if the mechanism was subject to high loads originating either in the swivelling of the wheels on the track or high loads originating in side forces applied to the side frame member.

In the case of high loads originating in the steering arms, such loads are isolated by abutments 181. In respect of excess loads originating in the rotation of side frame members such loads are isolated by abutments 133 provided on pillar 115 contacting abutments 134 on steering transfer box 112.

The forces required to steer the wheels is only a small fraction of the forces which may arise as described, and hence wear on the mechanism of steering transfer box is not excessive. Provision is made to lubricate the mechanism and exclude the entry of dirt. Springs 187 & 188 are provided with seats on their respective side frame members 99 & 113.

2154686

18

Whilst the first embodiment of is shown with drive to some wheels and the second embodiment is shown with no such drive, both embodiments can be with or without drive to any wheel.

5 Whilst in the first and second embodiments the tilt between the front and rear axle sets is conveyed and employed by mechanical means to steer the wheels, it should be understood that in other not shown embodiments other means such as electrical, electro-mechanical,
10 hydraulic or pneumatic means may be used.

In order to apply the invention to the design of a bogie it is necessary to calculate various parameters of the construction. As an aid to this a guide to the making of the necessary calculations is given below with
15 reference to the diagrammatic Figures 15-21.

Figure 16 is a plan view of a bogie while it is rounding a curve of mean radius R. The wheels are represented as narrow discs which are located at the mid-point axially of the wheel and rim and have centres at
20 points 77, 78, 79, 80. These discs contact the rail heads at a distance or track shown as distance 85 (also denoted as T) when running on a straight section of rail and at a larger distance 86 when negotiating a curved section of rail. This is because of the angled disposition of the
25 bogie illustrated in Figure 16. In practice, the centres of the rail heads may be determined from Figures 15 to 21 and the following equations and will vary between a minimum value 85 at straight sections of track and a maximum value 86 determined by minimum track radius.

30 Lines joining 77 and 80 and 78 and 79 are designated "virtual axles" and points 81 and 82 are at the axle mid-points. The front and rear axles in this view converge on the centre of the curve point 84 at an included angle γ .

It is well known that steel wheels when rolled on a
35 rail have an instantaneous direction of rolling precisely in the plane of the wheel. Hence, 77, 80, 84 and 78, 79,

2154686

84 in Fig. 16 are straight lines. For the purposes of this calculation, the rear axle is assumed to be horizontal and the front axle inclined at an angle θ to the horizontal. In practice, the rear axle will be inclined in the opposite sense to the front axle, but the total relative angle of inclination θ will be the same. The angle θ is shown greatly exaggerated.

Figure 15 is a view in the direction of arrow Y normal to the line 78, 84 in Figure 16. In this figure the virtual axle 78, 79 is seen to be inclined to the horizontal angle θ and line 78, 79 is the true length A of the front virtual axle. The front wheels and the topsurfaces of the inclined rail heads are shown in figure 15. The rail surfaces are inclined at an angle λ to the horizontal. As shown in more detail on Fig. 21 the chain dotted lines from point t to point 78 and extended, and point t to point 79 and extended represent the loci of the wheel centres as θ varies. The displacement of point 82 from the centre of the track is designated Q. Even for large steer angles the vertical position of 82 is essentially unchanged. H and I are the projected lengths of the axle in the vertical and horizontal planes.

Figure 17 is the side elevation of the bogie shown in Figure 16. The rear virtual axle 77, 80 and the front virtual axle 78, 79 are extended towards each other at their mid-points and are hinged at Z, its axis being inclined at an angle α to the vertical.

Figure 18 is a view on Fig. 17 in direction x. In this view the dimension E represents the true length of the leading arm 82, 83 and 78, 79 represents the true length A (as shown in Fig.16) of the virtual axle.

Figure 19 is a side elevation of the bogie when steering straight ahead. Dimensions C and D define the position of the pivot and α its angle of inclination. Dimension N defines the intersection of the pivot line with the rail level at point 87.

2154686

20

Figure 20 is a view on Figure 17 in direction V. Dimension H defining vertical shift between the ends of the front "virtual axle" (points 78, 79) is common to figure 17 and figure 20.

5 Figure 21 is an expanded view of Figure 15, showing displacement of the front "virtual axle" from its hypothetical neutral position. The "virtual axle" is assumed to be moved laterally by a distance Q (lateral shift of point 82a to point 82) and then rotated by angle
10 θ . It is assumed that the ends of the "virtual axle" (points 78, 79) will move along a straight line parallel to the rail surface. This assumption is considered correct for angles θ being typically very small. A lateral shift of both ends 78 and 79 of the "virtual axle"
15 are denoted as QR and QL respectively. The wheel radius R_w is shown as a distance between the wheel rail contact 20a and the end of the "virtual axle" 79a.

Method for design of the pivot

The following dimensions are given, or may be
20 calculated from given dimensions:

- Wheelbase (B) distance between points 81 and 82b (Fig. 19)
- Rail dihedral angle (λ) (Fig. 15 & 21)
- Wheel radius (R_w) (Fig. 21)
- Wheel/rail contact centres (T) distance 85 (Fig 15 & 16)
- 25 Radius of curvature, of the centre of the track (R) distance 81, 84 (Fig. 16)

The dimensions to be calculated are:

- 30 pivot inclination (α) (Fig. 17)
- leading arm length E (Fig. 18)

The pivot position which is defined by the distance of point 83 in front of rear axle (C) and the distance of point 83 below rear axle (D) or alternatively by intersection of the pivot line with the rail line at point 87 (distance N from the front contact
35 point 20b) (Fig 19)

- Front axle offset distance (Q) (Fig. 16 & 21)

2154686

21

Pivot rotation angle (β) (Fig 18)

Calculation Method

Defining Steering Gain (G)

The ratio of the amount of steering resulting from a twist imparted to the bogie from the rails is designated gain (G). This is defined as:

$$\text{gain (G)} = \frac{\text{steering angle } (\gamma)}{\text{angle twist angle } (\theta)}$$

Depending on the application, G may be of the order of between 1 and 8. Appropriate design value of gain should be selected for particular application.

Calculate Steering angle (γ)

$$\text{approx } \gamma = 2 \arcsin (B/2R)$$

this is assumed to be exact, ie $\gamma = 2 \arcsin (B/2R)$ _____ 1

15

Calculate twist angle (θ)

from gain $\theta = \gamma/G$ _____ 2

20

Calculate length of "virtual axle" (A) Ref. Fig. 21

$$A = T - 2Rw \sin \lambda$$
 _____ 3

Calculate Offset Distance Q Ref Fig. 21

25

Using sine rule $\frac{b}{\sin (\lambda - \theta)} = \frac{A}{\sin (180 - 2\lambda)}$

$$b = A \frac{\sin (\lambda - \theta)}{\sin (180 - 2\lambda)} = \frac{A \sin (\lambda - \theta)}{\sin 2\lambda}$$
 _____ 4a

30

Using sine rule $\frac{a}{\sin \lambda} = \frac{A}{\sin (180 - 2\lambda)}$

$$a = A \frac{\sin \lambda}{\sin (180 - 2\lambda)} = \frac{A \sin \lambda}{\sin 2\lambda}$$
 _____ 4b

35

2154686

Using sine rule $\frac{c}{\sin(\lambda + 0)} = \frac{A}{\sin(180 - 2\lambda)}$

5 $c = \frac{A \sin(\lambda + 0)}{\sin(180 - 2\lambda)} = \frac{A \sin(\lambda + 0)}{\sin 2\lambda}$ 4c

left wheel offset

10 $Q_1 = (a - b) \cos \lambda = \frac{A \cos \lambda (\sin \lambda - \sin(\lambda - 0))}{\sin 2\lambda}$ 4d

Right wheel offset

15 $Q_R = (c - a) \cos \lambda = \frac{A \cos \lambda (\sin(\lambda + 0) - \sin \lambda)}{\sin 2\lambda}$ 4e

Central offset

20 $Q = 1/2 (Q_1 + Q_R) = \frac{A \cos \lambda (\sin(\lambda + 0) - \sin(\lambda - 0))}{2 \sin 2\lambda}$

25 $Q = \frac{A \cos^2 \lambda \sin 0}{\sin 2\lambda}$ 5

NOTE: For typical small angles θ , variations between Q , Q_1 and Q_R would not exceed 0.5%.

30 Calculate i Refer Fig. 16

From triangle 84, 81, 88

35 $R = (R + Q + i / \cos \gamma) \cos \gamma$

$i = R - (R + Q) \cos \gamma$ 6

Calculate pivot inclination α

Refer Fig. 17

$$H = A \sin \theta \quad \underline{\hspace{2cm}} \quad 7a$$

$$5 \quad I = A \cos \theta \quad \underline{\hspace{2cm}} \quad 7b$$

$$J = I \sin \gamma \quad \underline{\hspace{2cm}} \quad 7c$$

$$\alpha = \arctan (H/J) = \arctan (\tan \theta / \tan \gamma) \quad \underline{\hspace{2cm}} \quad 8$$

10

NOTE: Practical approximation of $\alpha = \arctan (1/G)$ may be used if non exact solution is required.

Calculate pivot rotation angle β

Refer Fig. 18

15

$$M = H / \sin \alpha = A \sin \theta / \sin \alpha \quad \underline{\hspace{2cm}} \quad 9$$

$$\beta = \arcsin (M/A) = \arcsin (\sin \theta / \sin \alpha) \quad \underline{\hspace{2cm}} \quad 10$$

20

Calculate leading arm E

Refer Fig. 18

$$E = i / \sin \beta \quad \underline{\hspace{2cm}} \quad 11$$

Calculate pivot position D & C

Refer Fig. 19

25

$$D = E \sin \alpha \quad \underline{\hspace{2cm}} \quad 12$$

$$C = B - (E \cos \alpha) \quad \underline{\hspace{2cm}} \quad 13$$

30

Calculate pivot intersection line with the rail level N Refer Fig. 19

$$N = B - C - (Rw \cos \lambda - D) \tan \alpha \quad \underline{\hspace{2cm}} \quad 14$$

$$N = E \cos \alpha - (Rw \cos \lambda - E \sin \alpha) \tan \alpha \quad \underline{\hspace{2cm}} \quad 15$$

35

2154686

The embodiments of the invention as described above are given by way of example only as constituting preferred forms of the invention defined broadly above in its various aspects.

5 It will be appreciated by persons skilled in the art that numerous variations and/or modifications may be made to the invention as shown in the specific embodiment without departing from the spirit or scope of the broadly described. The present embodiments are therefore to be
10 considered in all respects as illustrative and not restrictive.

1. A railway bogie adapted to run on a railway track having two rails laterally offset about a track centre line, the bogie comprising a pair of axle sets one at each end, each axle set having two mutually opposite independently rotating wheels, characterized in that the railway bogie is a self steering railway bogie, each of the wheels of at least one axle set has a peripheral profile adapted to engage one of said rails respectively such that, on being displaced laterally with respect to the other axle set and relative to said track centre line, one wheel will rise and the other will fall with respect to the wheels of the other axle set whereby said at least one axle set undergoes a tilt change with respect to said other axle set and means responsive to said tilt change to steer one or both axle sets.

10

2. A self steering railway bogie as claimed in claim 1, wherein each wheel has an axle whose axis is inclined downwardly towards said track centre line and said peripheral profile where it contacts said track is also downwardly inclined towards said track centre line wherein said means responsive to said tilt change of one of said axle sets with respect to the other axle set is connected by a linkage to the axles and is arranged so as to steer each said axle set so that each wheel of the set substantially aligns with the centre line of the respective rail beneath it.

15

3. A self steering railway bogie as claimed in claim 2, in which said peripheral profile is cylindrical.

20

4. A self steering railway bogie as claimed in claim 1, 2, or 3, wherein lines passing through contact faces between the wheels and the rails and normal thereto intersect at a height at least substantially equal to the height of the centre of gravity of the bogie and any carriage supported thereby.

25

5. A self steering railway bogie as claimed in claim 1, 2, or 3 wherein lines passing through contact faces between the wheels and the rails and normal thereto intersect at a height substantially higher than the centre of gravity of the bogie and any carriage supported thereby.

30

6. A self steering railway bogie as claimed in claim 1, wherein at least one of said axle sets is pivotal about an axis located at the mid plane of the axle set and inclined to the vertical in the

direction of the centre line of the track.

5 7. A self steering railway bogie as claimed in claim 6, wherein both axle sets are pivotable about an axis located at the mid plane of the axle set and inclined to the vertical, means being provided to fix either axle set against rotation about its axis.

10 8. A self steering railway bogie as claimed in claim 1, wherein each wheel axle is individually pivoted about a steering axis, the steering axes of each pair of wheels being disposed on opposite ends of the respective axle set, the pivots of the wheel axles of each pair on the same side of the bogie being interconnected by a longitudinally extending side frame member, the side frame members being relatively rotatable about a common axis transverse to the bogie, said rotation caused by a relative rise of two diagonally opposite wheels, a steering transfer box responsive to said rotation being connected to linkage means arranged to steer at least one pair of wheel axles.

15 9. A self steering railway bogie as claimed in claim 1, wherein said peripheral profile of each of the wheels of said at least one axle set is inclined downwardly towards said track centre line whereby lateral offset of said axle set with respect to said track centre line produces a component of rotation of this axle set about a horizontal axis parallel with said track centre line, wherein the bogie also comprises steering means for said at least one axle set said steering means comprising a linkage means between said pair of axle sets, said linkage means being arranged such that said component of rotation also produces relative rotation of said pair of axle sets, thereby steering one axle set with respect to the other axle set and maintaining the lateral position of the bogie with respect to said track centre line.

25 10. A self steering railway bogie as claimed in claim 9, wherein said linkage means comprises an instantaneous steering axis between said pair of axle set which is inclined with respect to the vertical and arranged such that said component of rotation also produces relative rotation of said pair of axle sets about said instantaneous steering axis.

30 11. A self steering railway bogie as claimed in claim 9, wherein said linkage means comprises

an instantaneous steering axis between at least one axle set and the bogie which is inclined with respect to the vertical and arranged such that said component of rotation also produces relative rotation of said at least one axle set with respect to the bogie about said instantaneous steering axis.

5

12. A self steering railway bogie as claimed in claim 1, wherein said bogie comprises a pair of longitudinal side frame members one at each side, each side frame member comprising two independently rotating wheels each of which belongs to a respective one of said pair of axle sets, said wheels of each side frame member being located at opposite ends of said bogie and being adapted to engage the same rail said peripheral profile of at least one wheel of each side frame member being inclined downwardly towards said track centre line whereby a difference between the lateral offset of said wheels of either side frame member with respect to the same rail produces a rise of one wheel with respect the other and hence a component of rotation of said respective side frame member about a horizontal axis perpendicular to said track centre line, wherein at least one wheel of each said side frame member is pivoted about a respective steering axis, and linkage means is provided to steer said at least one wheel about its steering axis as a function of said component of rotation of its respective side frame member, thereby maintaining the lateral position of the bogie with respect to said track centre line.

20

13. A self steering bogie as claimed in claim 12, wherein the wheels at the front end of each side frame member are pivoted about respective steering axes and interconnected by a transverse tie rod, causing the steering applied to one front wheel of the bogie to be imparted to the other front wheel.

25

14. A self steering railway bogie as claimed in claim 12, wherein the wheels at the rear end of each side frame member are pivoted about respective steering axes and interconnected by a transverse tie rod, causing the steering applied to one rear wheel of the bogie to be imparted to the other rear wheel.

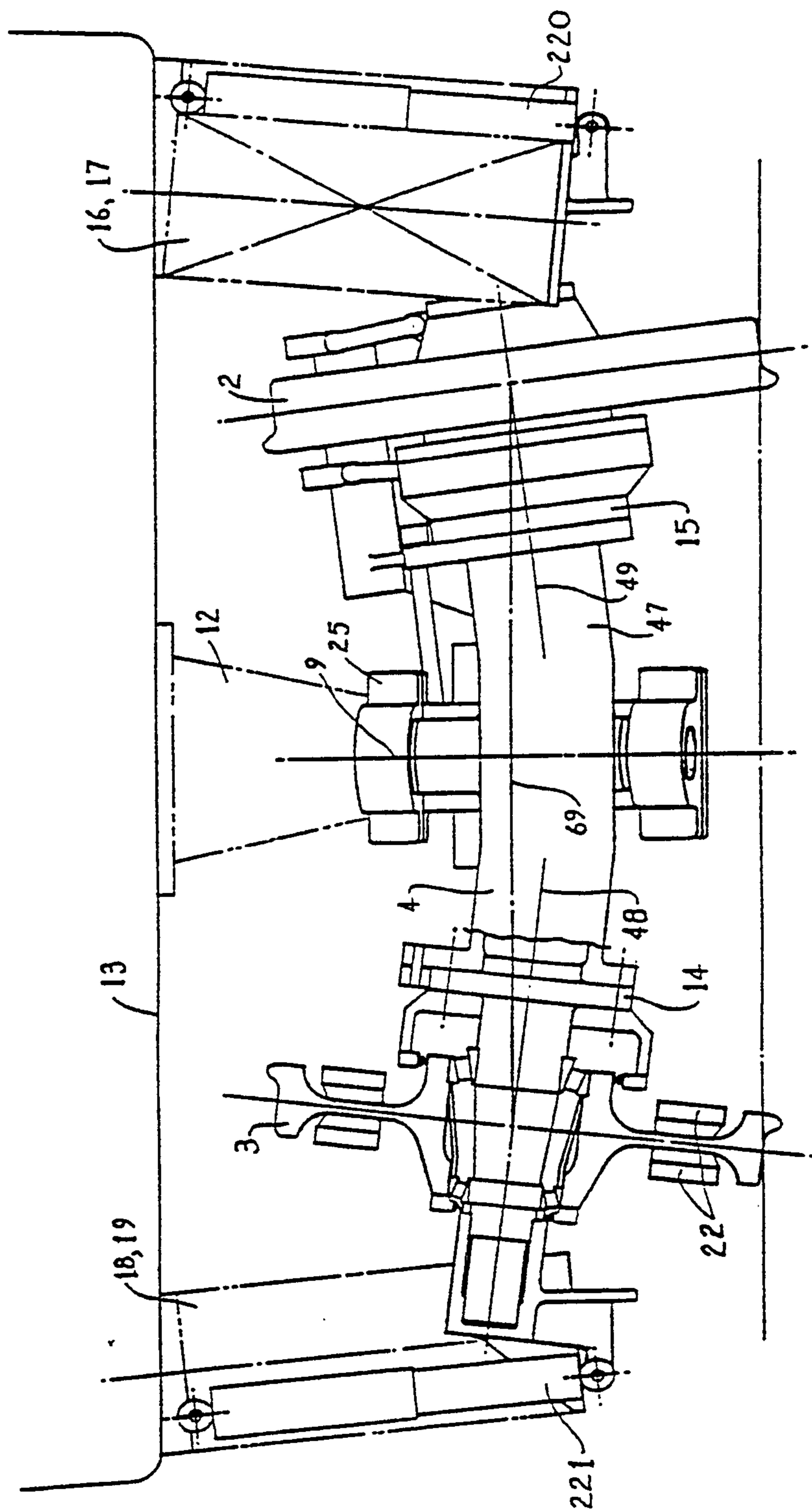

FIG 2.

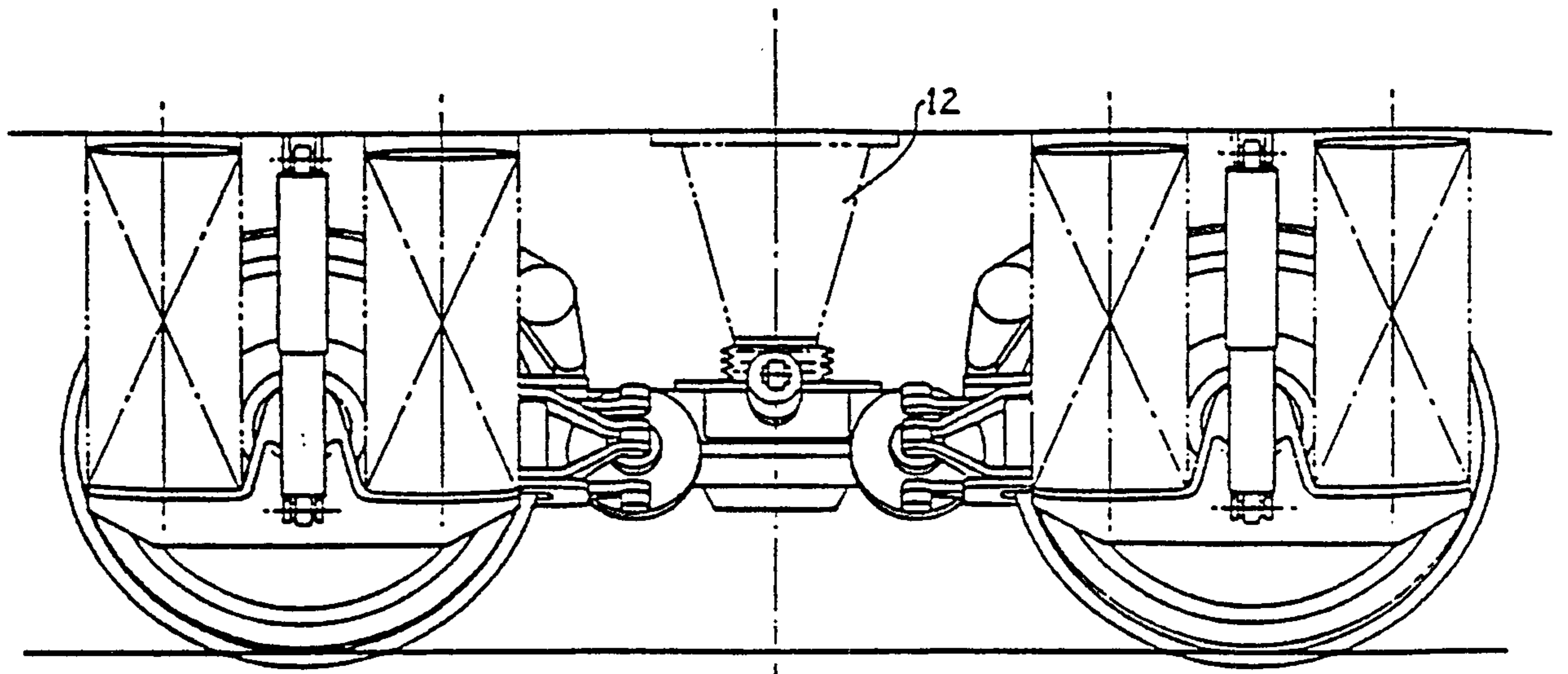

FIG. 3.

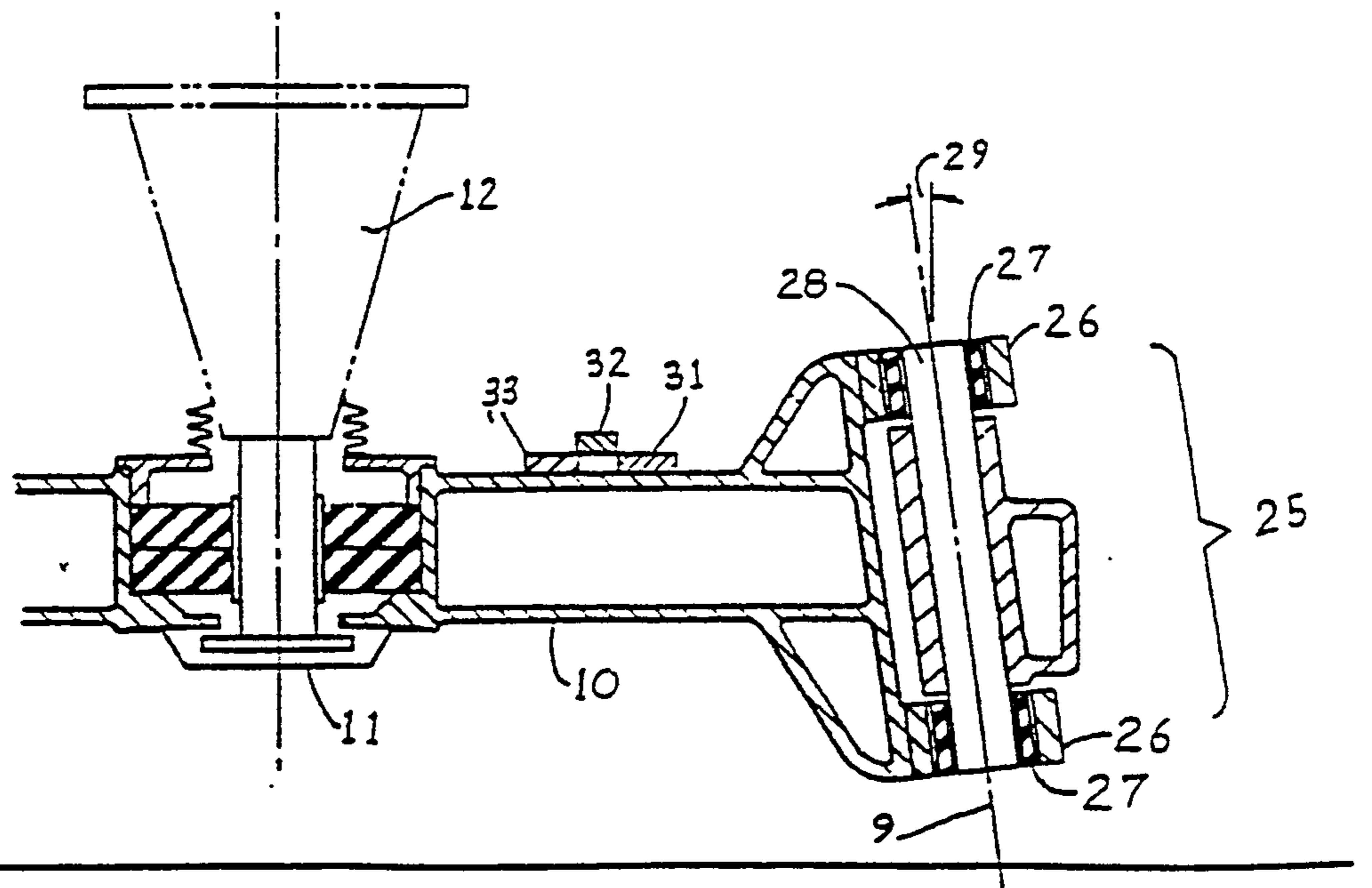

FIG. 4.

4/13

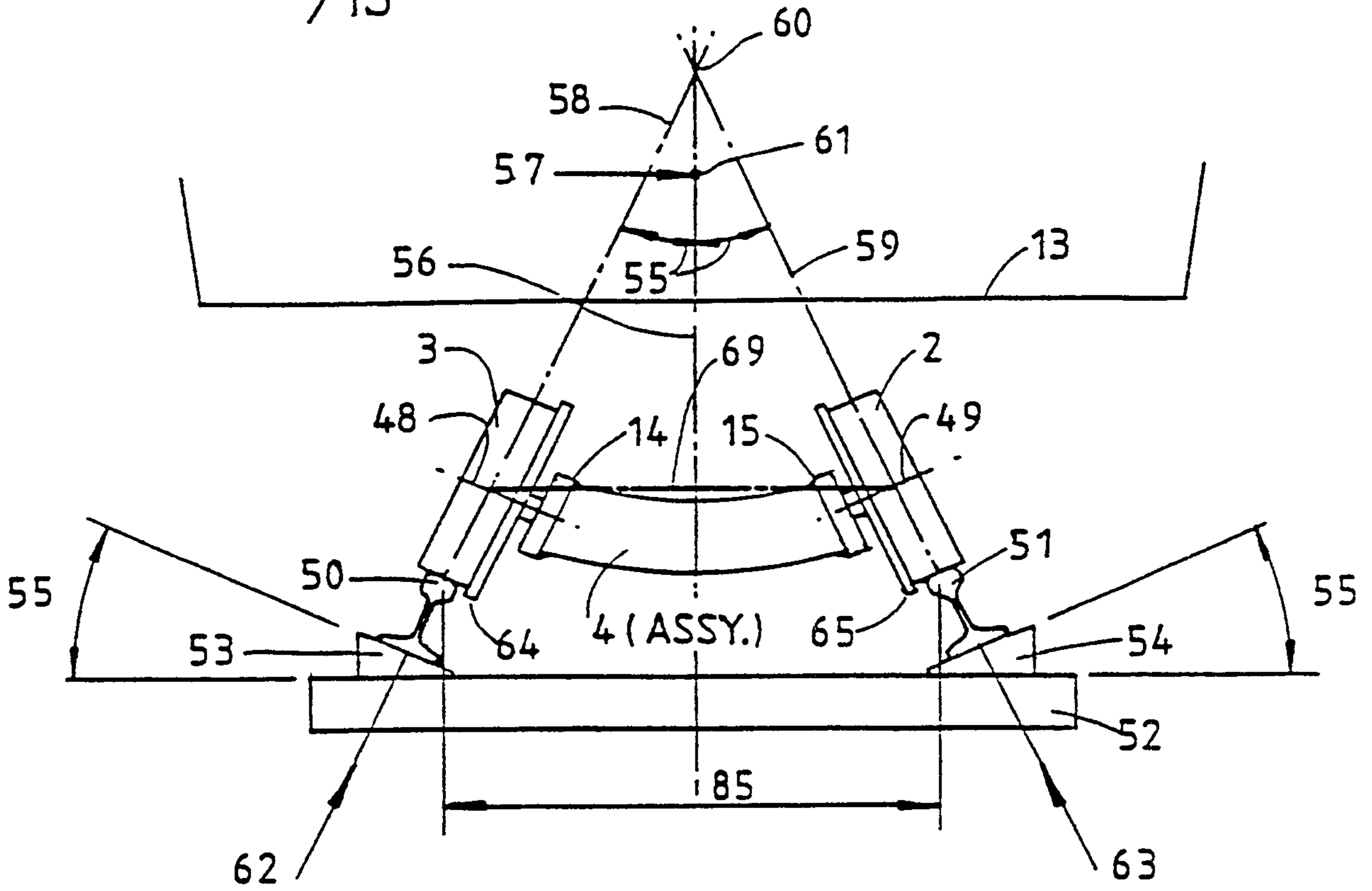

FIG 5

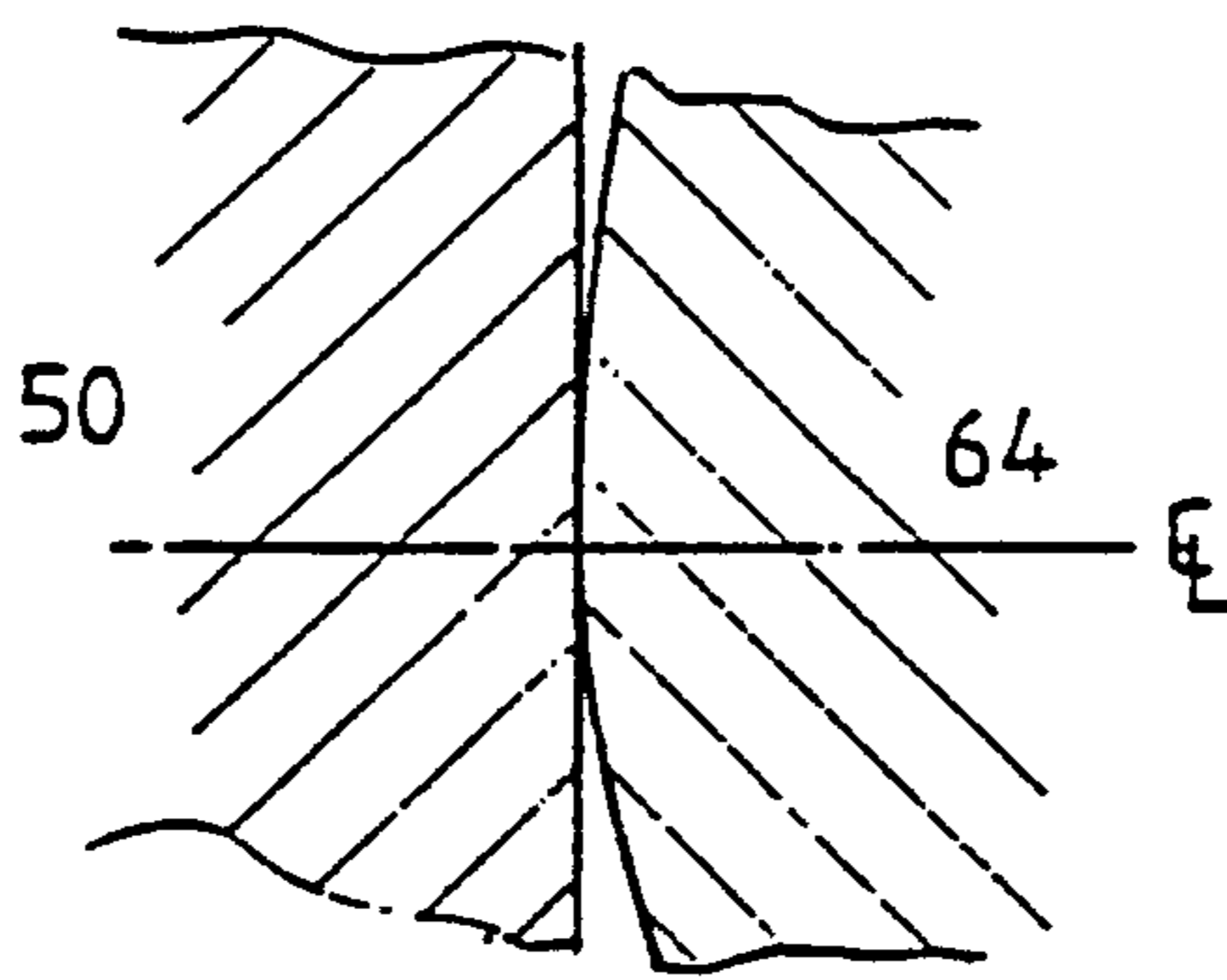

FIG 5a

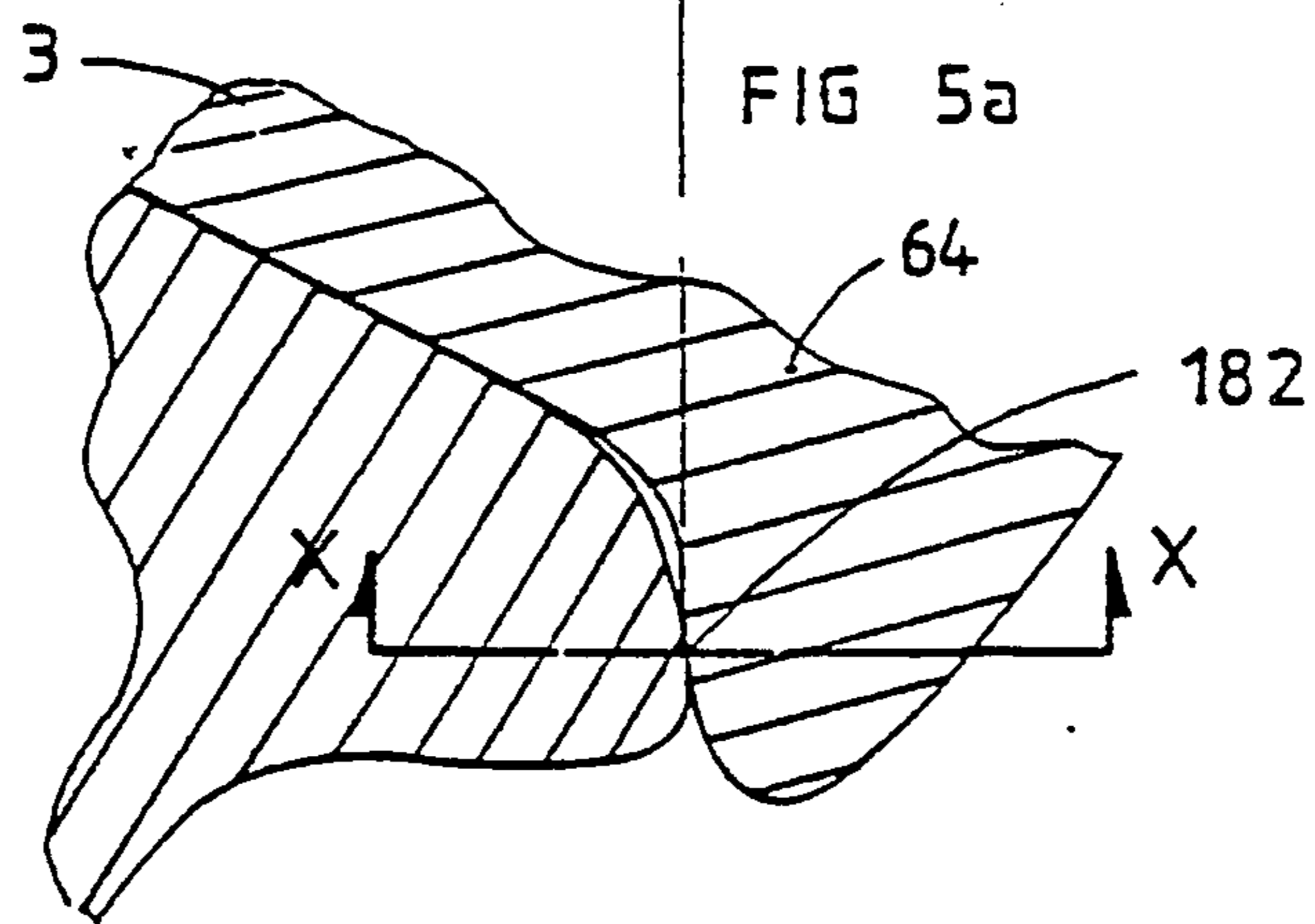

FIG 5b

2154686

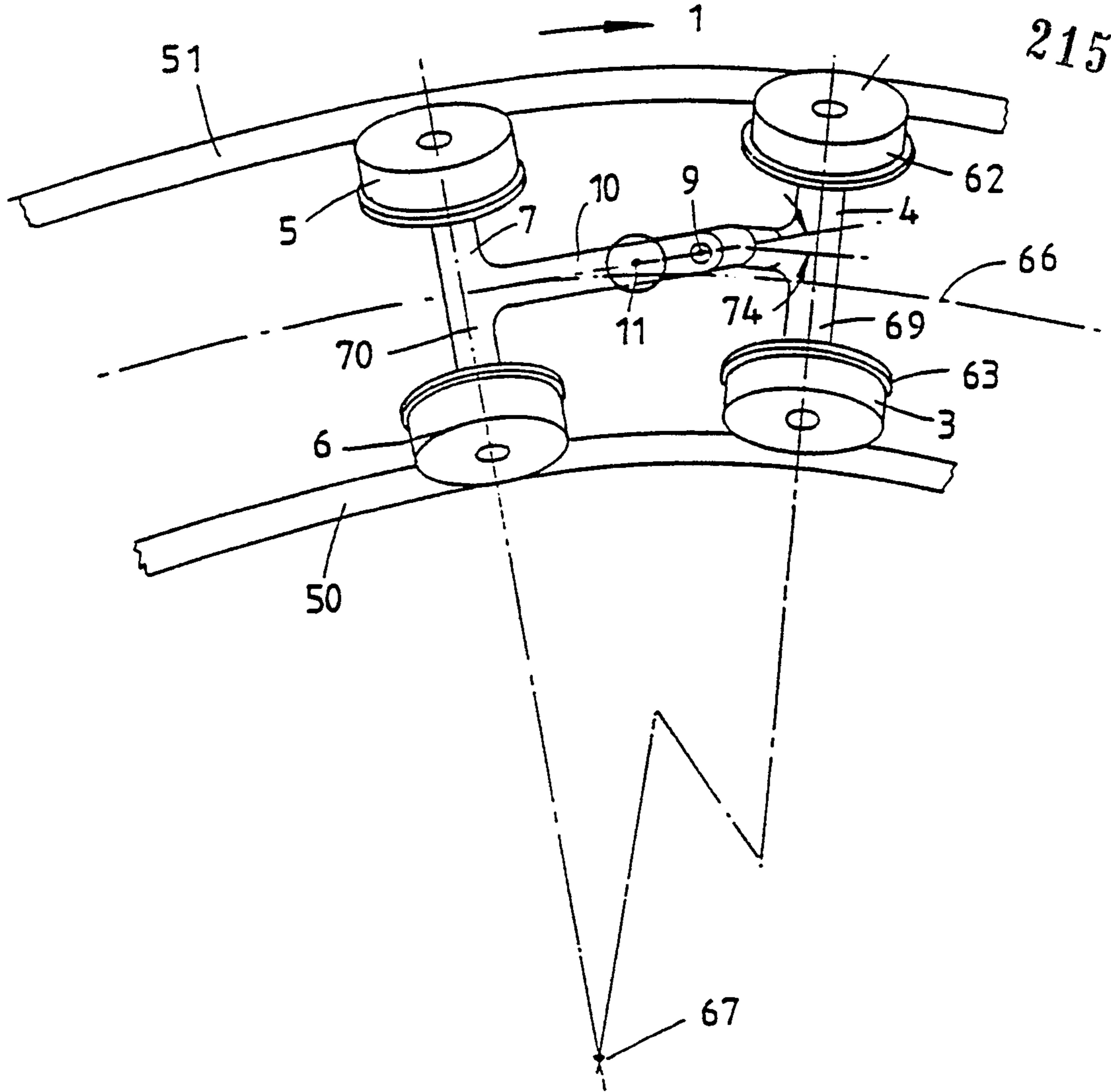

FIG 6

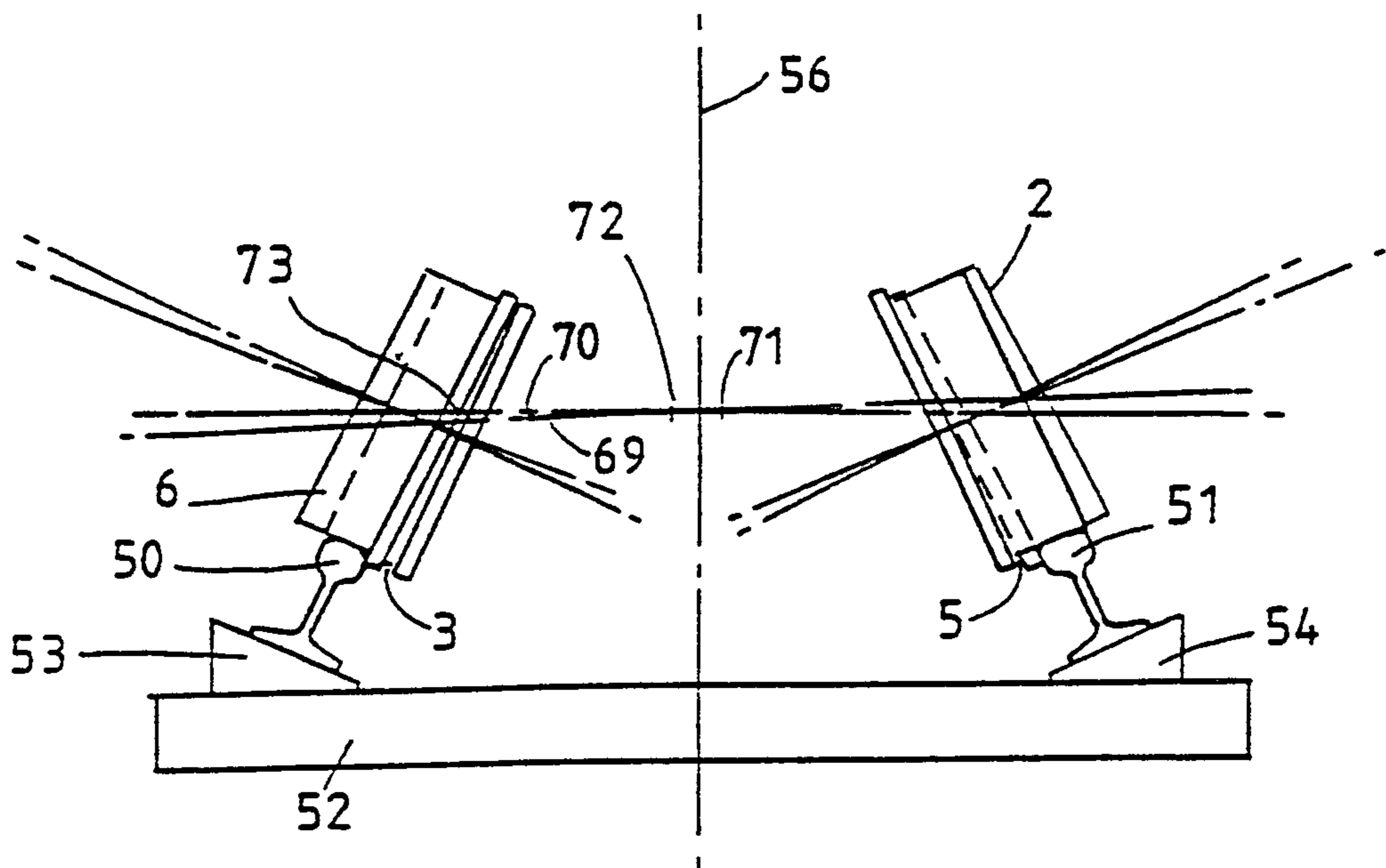

FIG 7

2154686

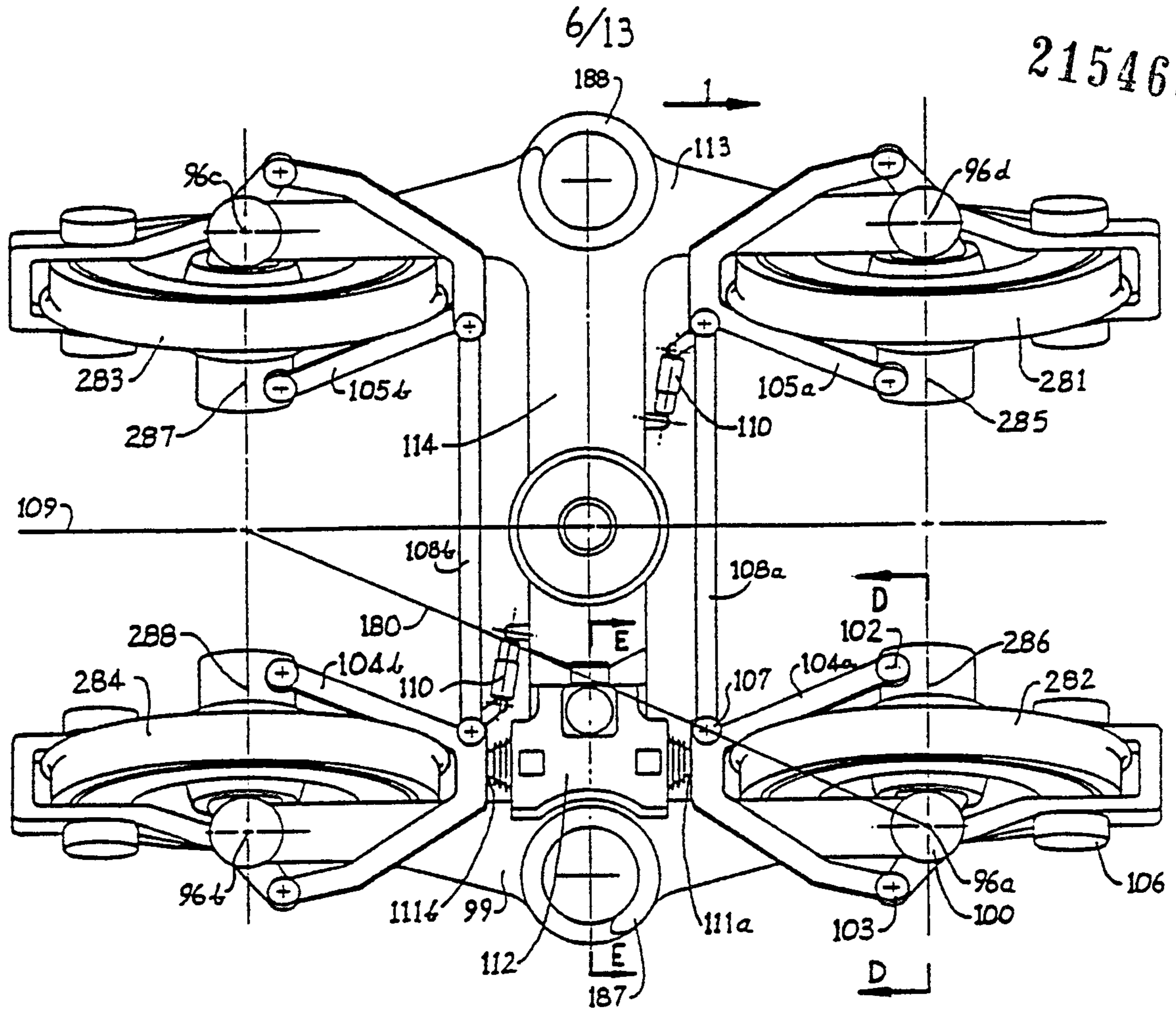

FIG 8.

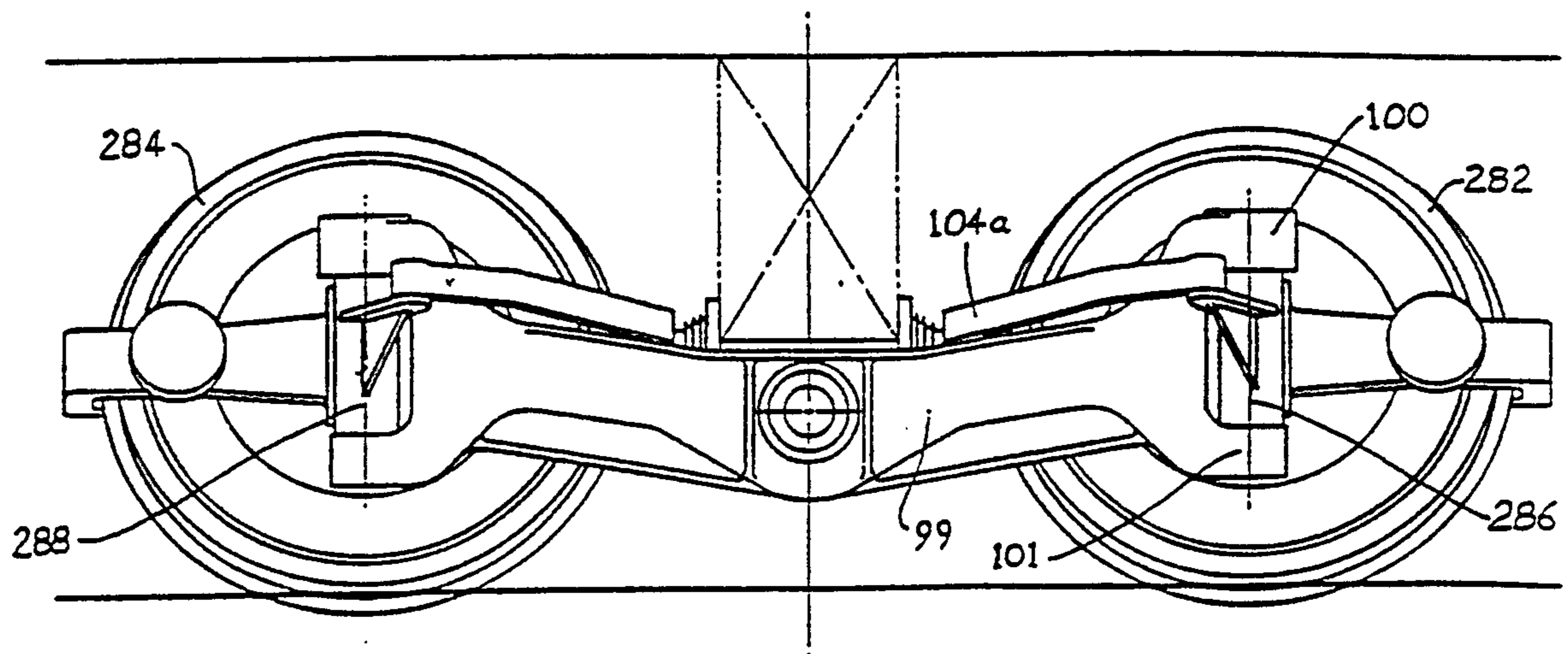

FIG 10.

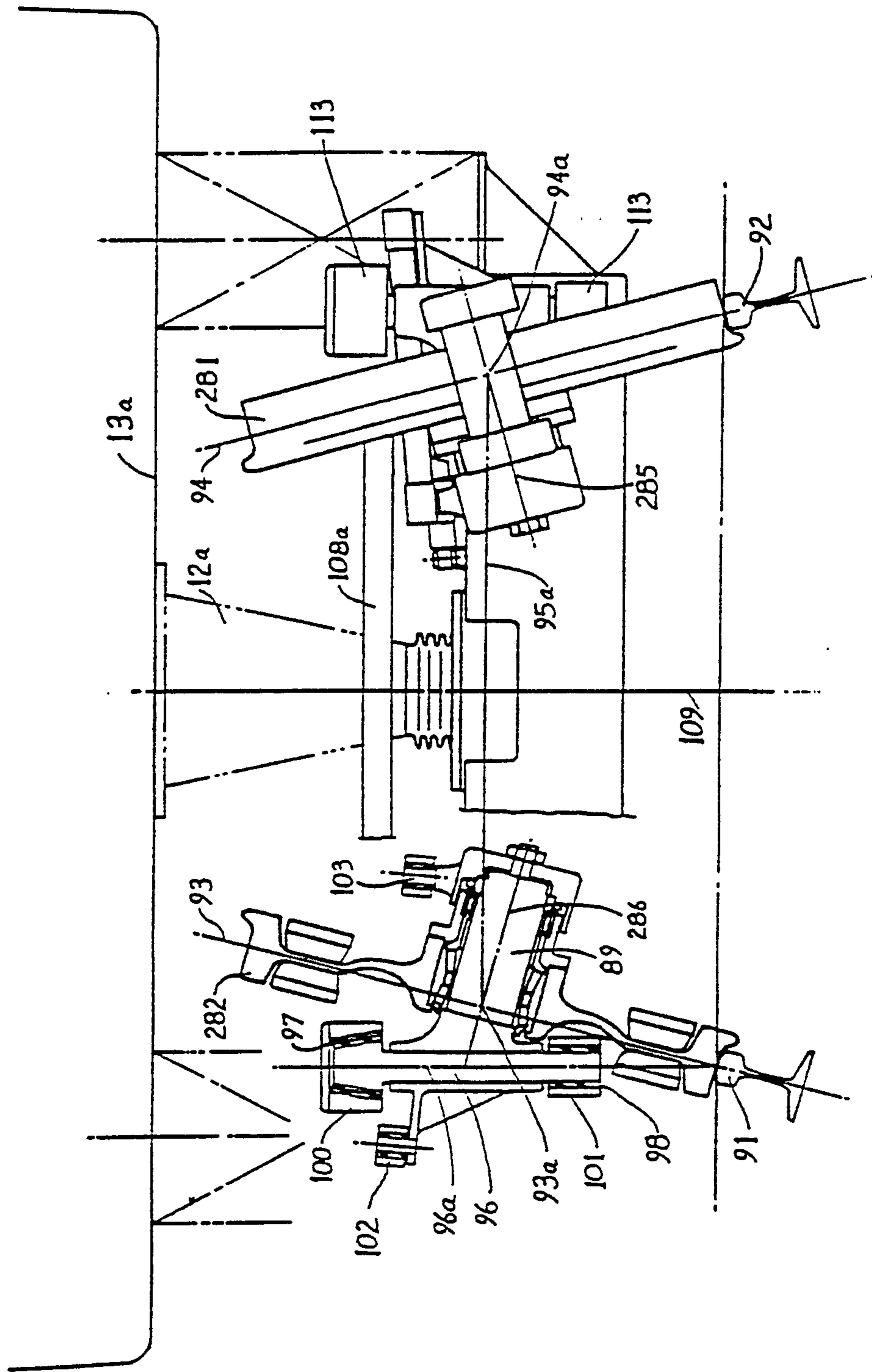

FIG 9.

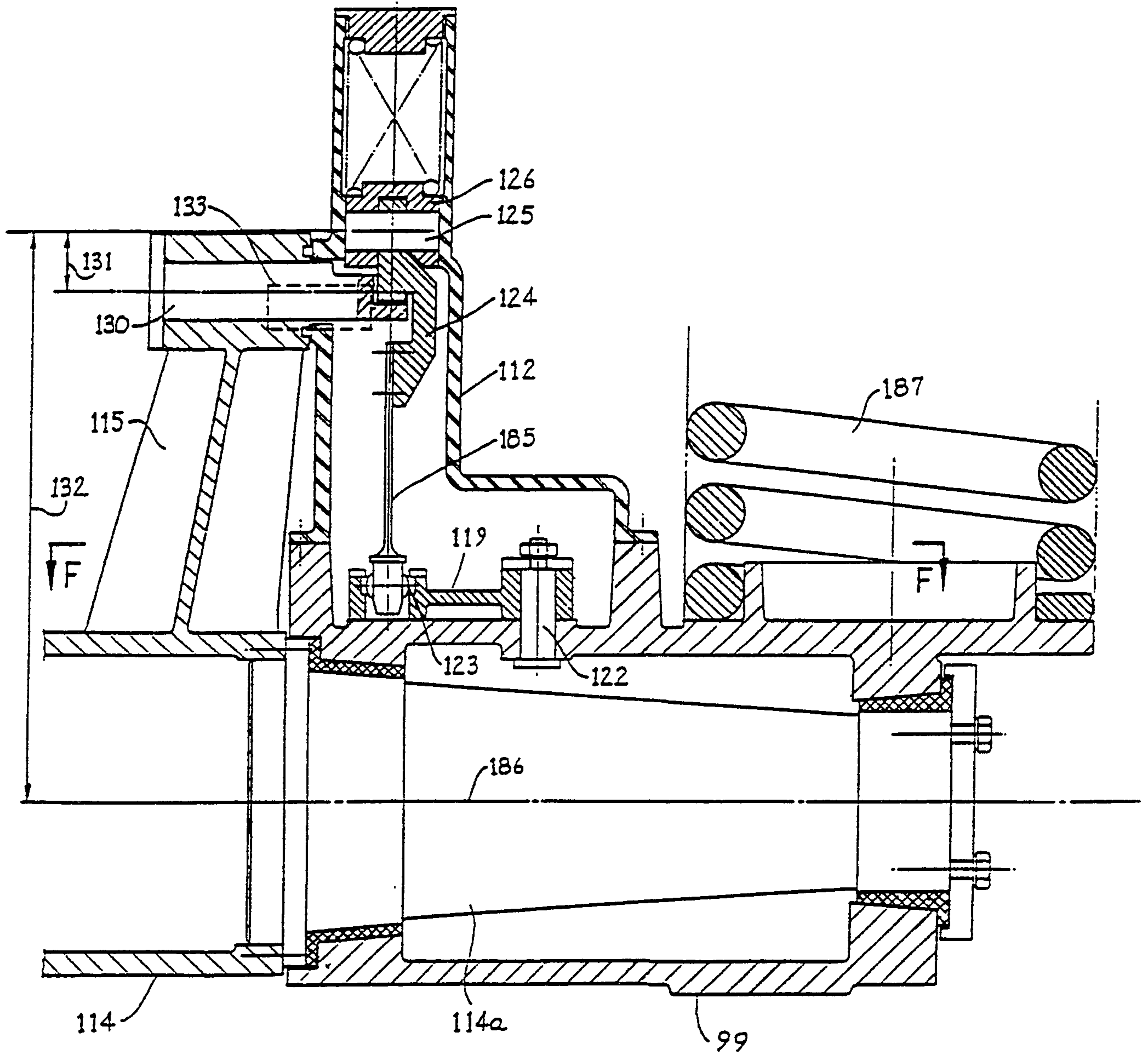

FIG 12.

10/13

2154686

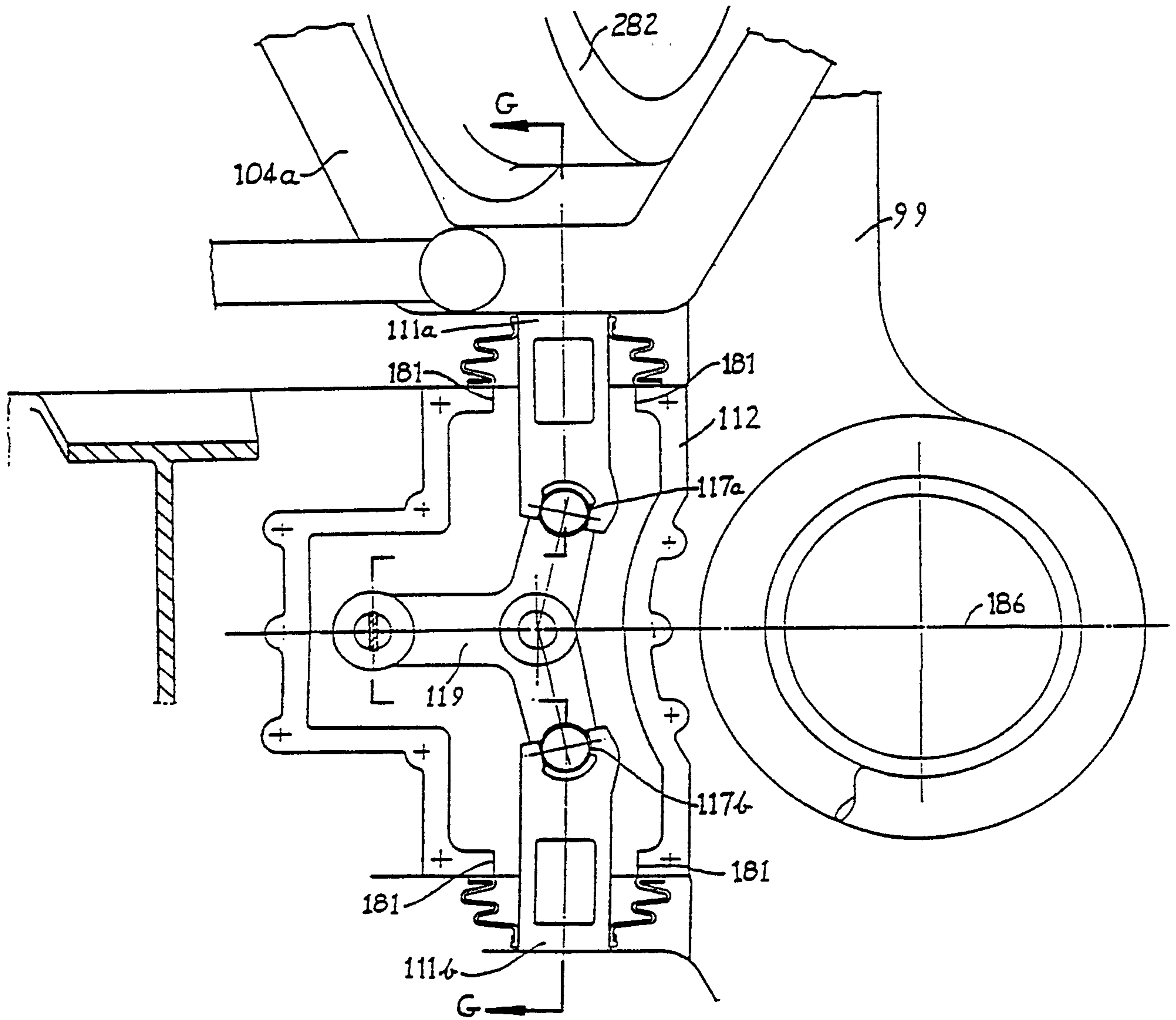

FIG 13.

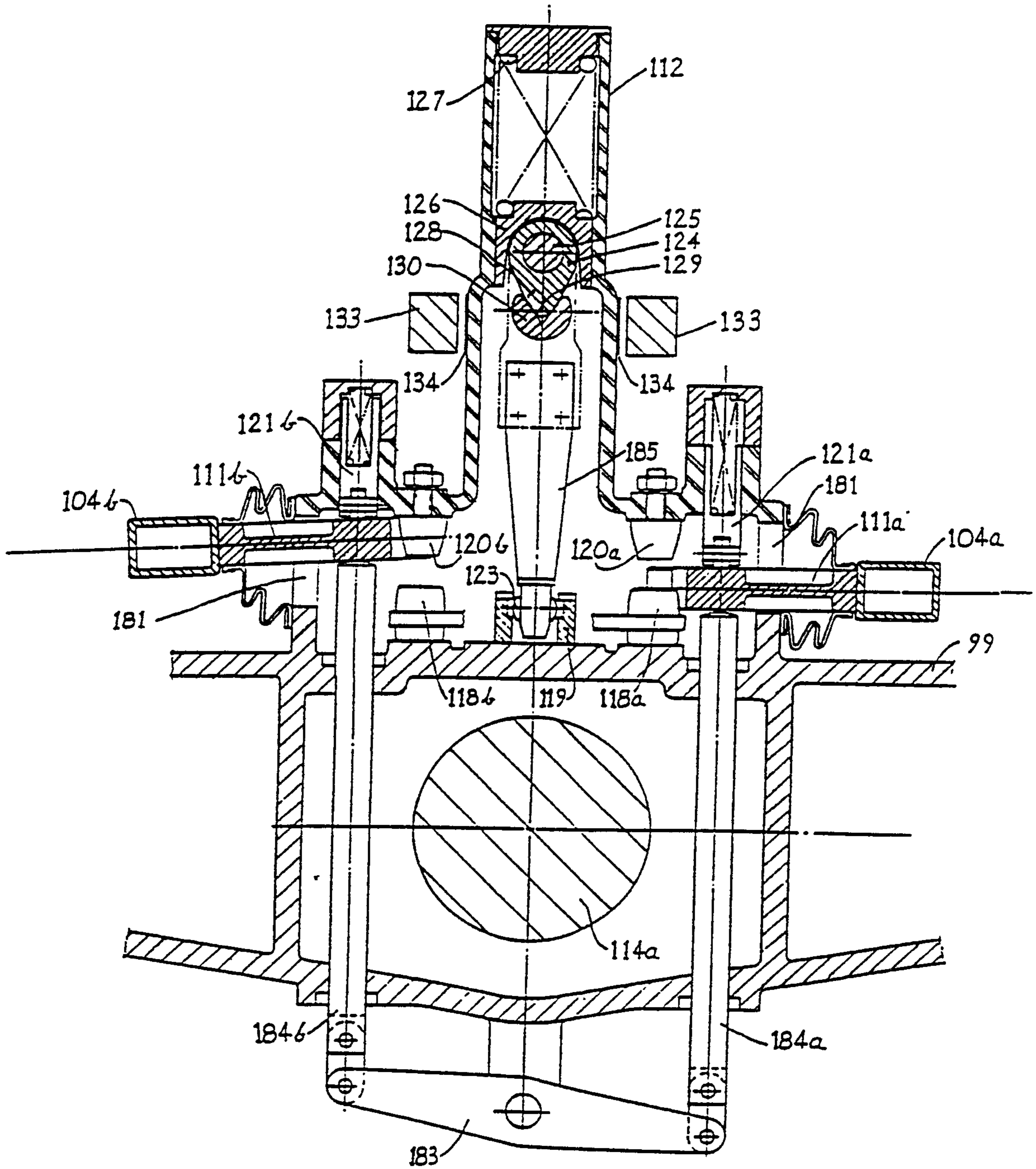

FIG. 14.

SUBSTITUTE SHEET (Rule 26)

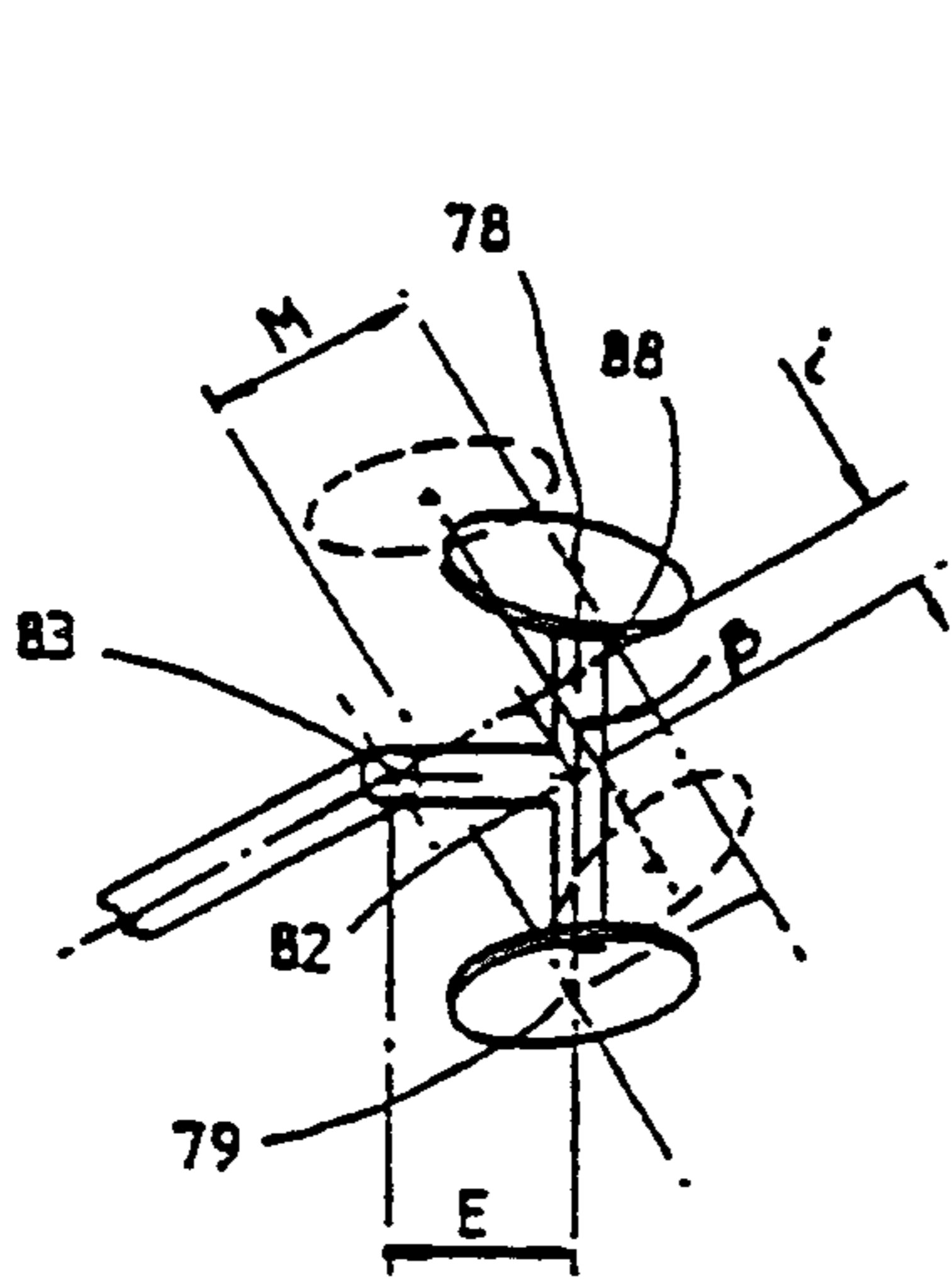

FIG 18

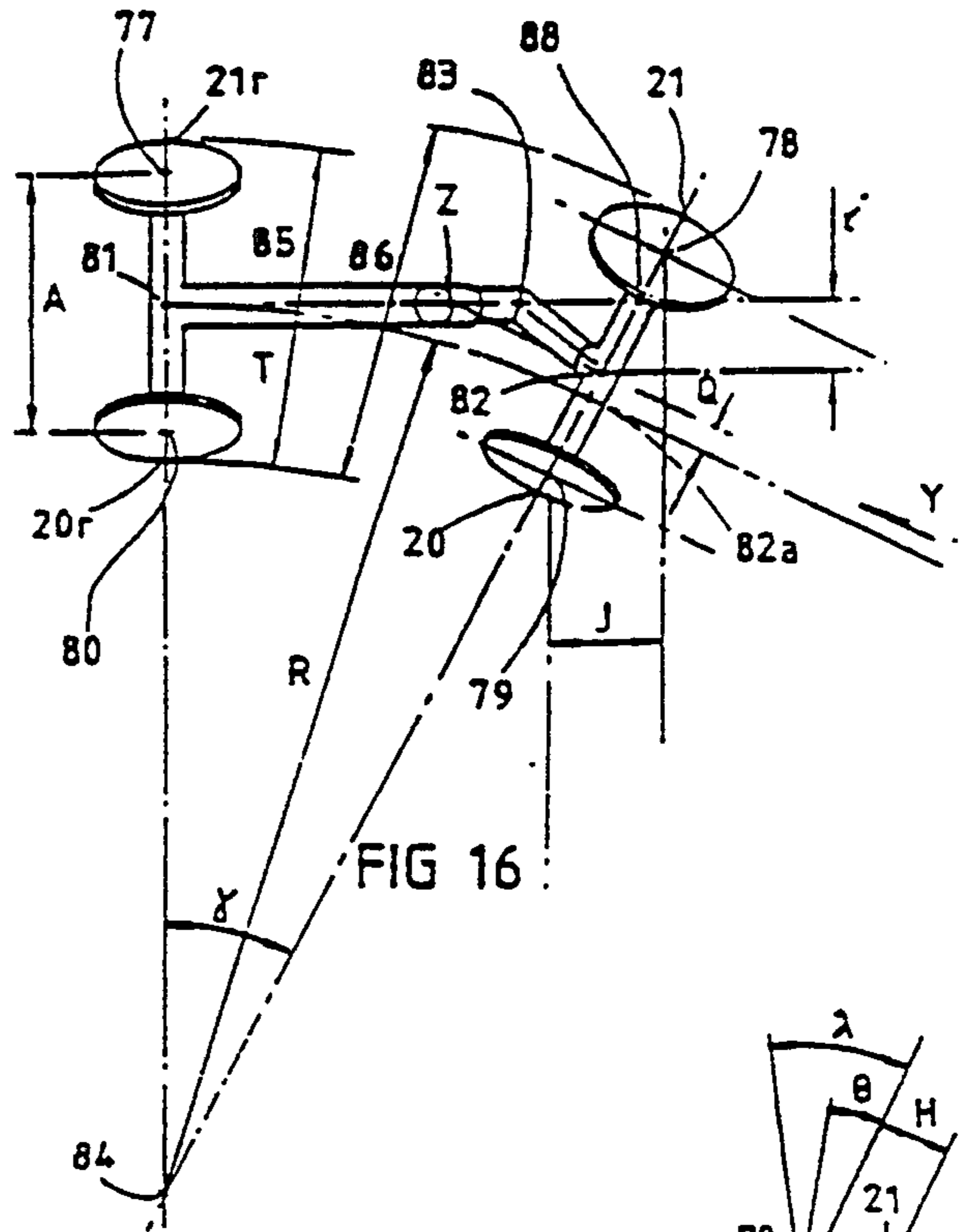

FIG 16

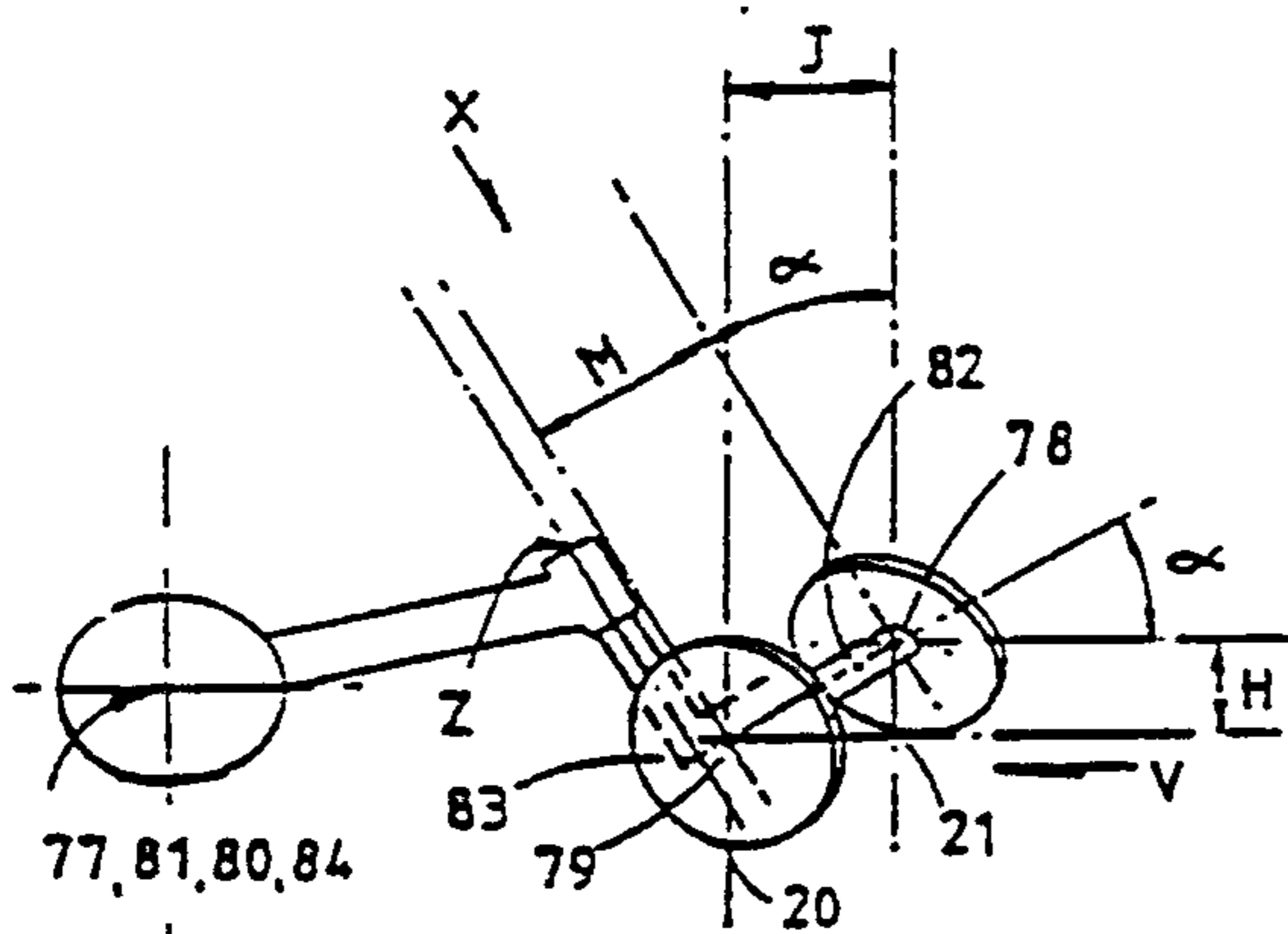

FIG 17

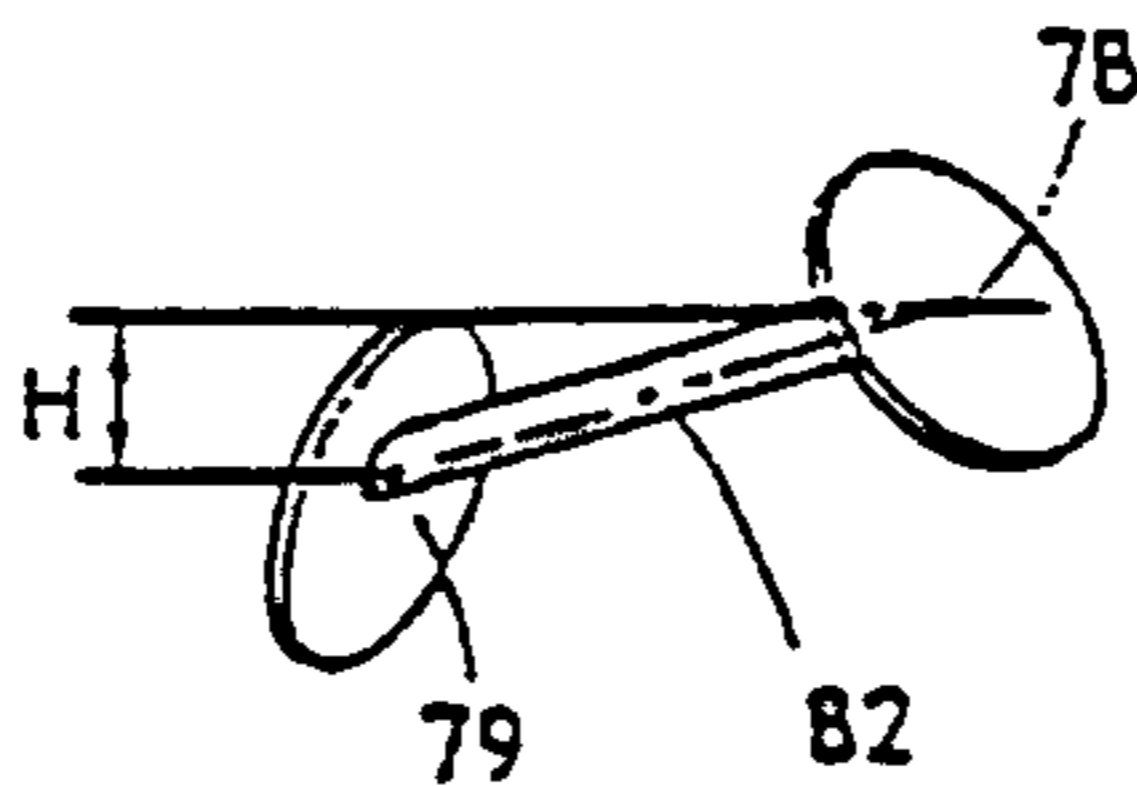

FIG 20

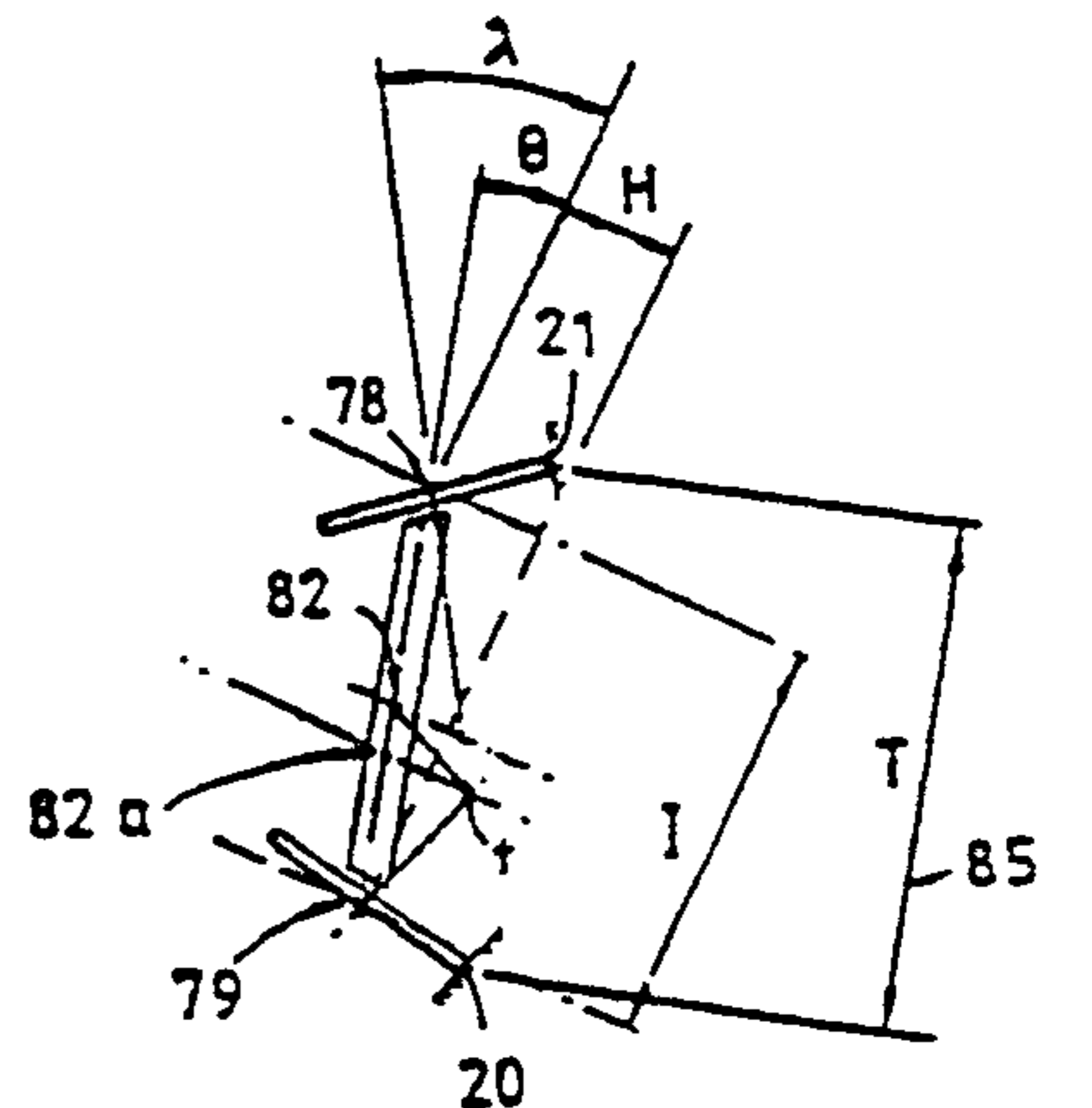

FIG 15

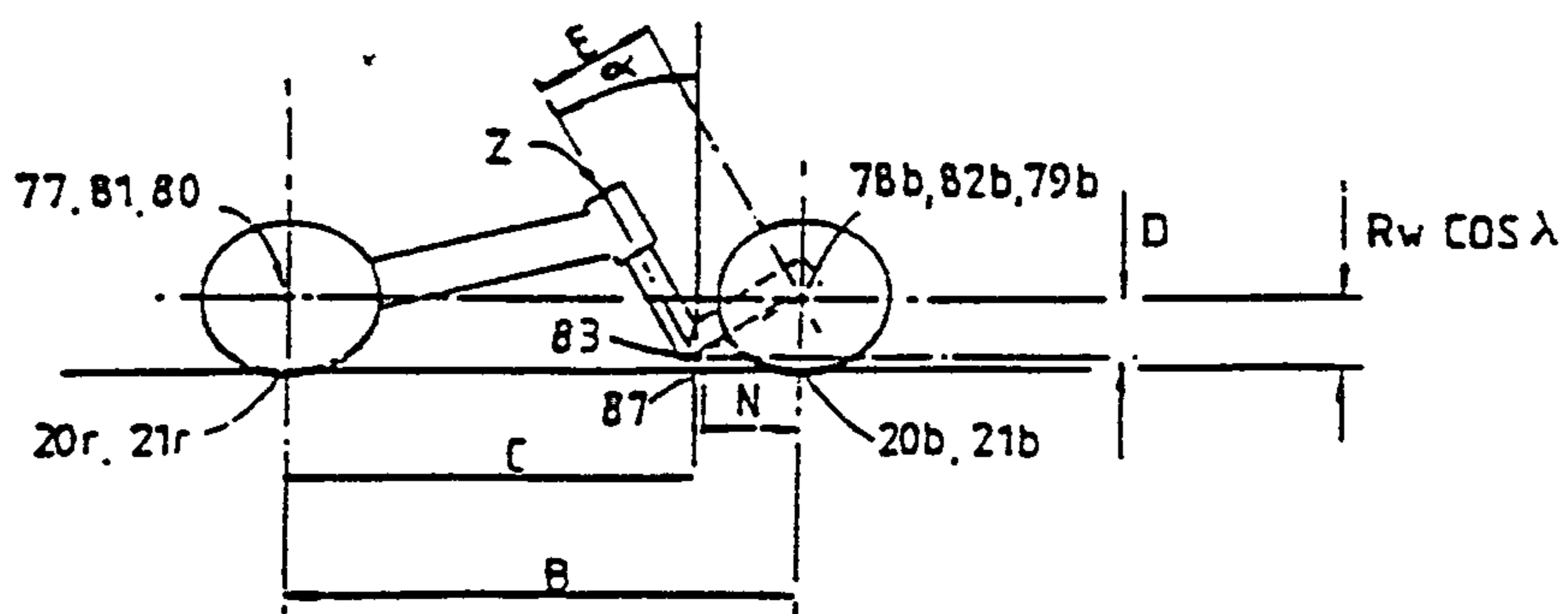

FIG 19

2154686

13/13

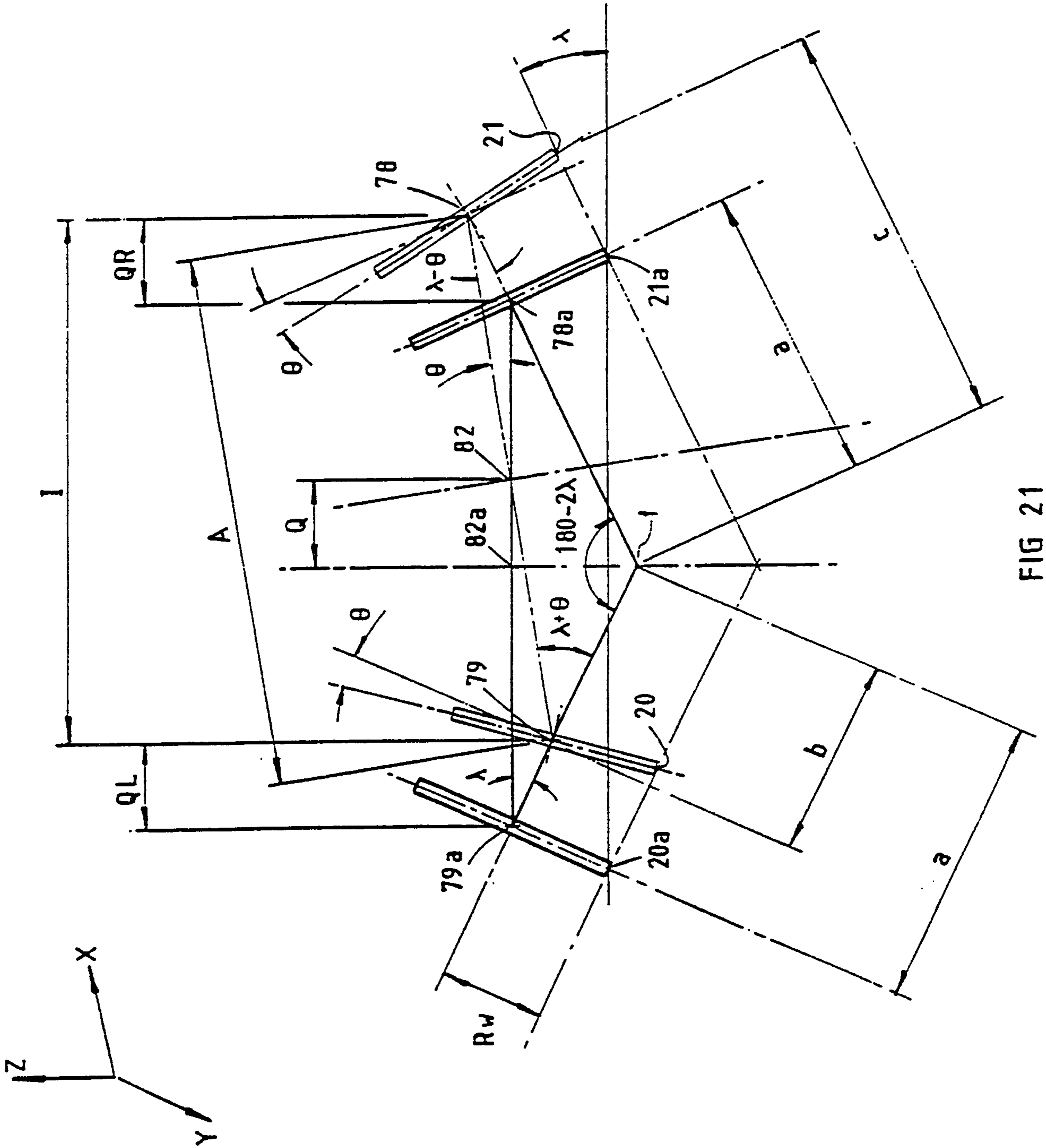

FIG 21

