



INTERNATIONAL APPLICATION PUBLISHED UNDER THE PATENT COOPERATION TREATY (PCT)

<p>(51) International Patent Classification <sup>7</sup> : <b>A45D 6/00</b></p>	<p><b>A1</b></p>	<p>(11) International Publication Number: <b>WO 00/67608</b> (43) International Publication Date: 16 November 2000 (16.11.00)</p>
---	------------------	---

<p>(21) International Application Number: PCT/US00/12134 (22) International Filing Date: 4 May 2000 (04.05.00) (30) Priority Data: 09/306,283 6 May 1999 (06.05.99) US (71) Applicant: CONAIR CORPORATION [US/US]; One Cummings Point Road, Stamford, CT 06904 (US). (72) Inventor: LEUNG, Anthony; 2B 41 Braemar Hill Road, North Point, Hong Kong (CN). (74) Agent: RUGGIERO, Charles, N., J.; Ohlandt, Greeley, Ruggiero &amp; Perle, L.L.P., 9th Floor, One Landmark Square, Stamford, CT 06901-2682 (US).</p>	<p>(81) Designated States: AE, AL, AM, AT, AU, AZ, BA, BB, BG, BR, BY, CA, CH, CN, CR, CU, CZ, DE, DK, DM, EE, ES, FI, GB, GD, GE, GH, GM, HR, HU, ID, IL, IN, IS, JP, KE, KG, KP, KR, KZ, LC, LK, LR, LS, LT, LU, LV, MA, MD, MG, MK, MN, MW, MX, NO, NZ, PL, PT, RO, RU, SD, SE, SG, SI, SK, SL, TJ, TM, TR, TT, TZ, UA, UG, UZ, VN, YU, ZA, ZW, ARIPO patent (GH, GM, KE, LS, MW, SD, SL, SZ, TZ, UG, ZW), Eurasian patent (AM, AZ, BY, KG, KZ, MD, RU, TJ, TM), European patent (AT, BE, CH, CY, DE, DK, ES, FI, FR, GB, GR, IE, IT, LU, MC, NL, PT, SE), OAPI patent (BF, BJ, CF, CG, CI, CM, GA, GN, GW, ML, MR, NE, SN, TD, TG).</p> <p><b>Published</b> <i>With international search report.</i> <i>With amended claims.</i></p>
--	--

<p>(54) Title: HAIR CURLER AND HEATER</p> <p>(57) Abstract</p> <p>A hair curler (1) comprises a pair of substantially semi-cylindrical, metal members (12a, 12b) having opposed side faces. The members (12a, 12b) are joined at one end by a bridge (9) that separates the side faces of the metal members (12a, 12b) by a distance adapted to receive a rail-like heat conductor.</p>	
---	--

*FOR THE PURPOSES OF INFORMATION ONLY*

Codes used to identify States party to the PCT on the front pages of pamphlets publishing international applications under the PCT.

AL	Albania	ES	Spain	LS	Lesotho	SI	Slovenia
AM	Armenia	FI	Finland	LT	Lithuania	SK	Slovakia
AT	Austria	FR	France	LU	Luxembourg	SN	Senegal
AU	Australia	GA	Gabon	LV	Latvia	SZ	Swaziland
AZ	Azerbaijan	GB	United Kingdom	MC	Monaco	TD	Chad
BA	Bosnia and Herzegovina	GE	Georgia	MD	Republic of Moldova	TG	Togo
BB	Barbados	GH	Ghana	MG	Madagascar	TJ	Tajikistan
BE	Belgium	GN	Guinea	MK	The former Yugoslav Republic of Macedonia	TM	Turkmenistan
BF	Burkina Faso	GR	Greece	ML	Mali	TR	Turkey
BG	Bulgaria	HU	Hungary	MN	Mongolia	TT	Trinidad and Tobago
BJ	Benin	IE	Ireland	MR	Mauritania	UA	Ukraine
BR	Brazil	IL	Israel	MW	Malawi	UG	Uganda
BY	Belarus	IS	Iceland	MX	Mexico	US	United States of America
CA	Canada	IT	Italy	NE	Niger	UZ	Uzbekistan
CF	Central African Republic	JP	Japan	NL	Netherlands	VN	Viet Nam
CG	Congo	KE	Kenya	NO	Norway	YU	Yugoslavia
CH	Switzerland	KG	Kyrgyzstan	NZ	New Zealand	ZW	Zimbabwe
CI	Côte d'Ivoire	KP	Democratic People's Republic of Korea	PL	Poland		
CM	Cameroon	KR	Republic of Korea	PT	Portugal		
CN	China	KZ	Kazakistan	RO	Romania		
CU	Cuba	LC	Saint Lucia	RU	Russian Federation		
CZ	Czech Republic	LI	Liechtenstein	SD	Sudan		
DE	Germany	LK	Sri Lanka	SE	Sweden		
DK	Denmark	LR	Liberia	SG	Singapore		
EE	Estonia						

## HAIR CURLER AND HEATER

### BACKGROUND OF THE INVENTION

#### 5 1. Field of the Invention

This invention relates generally to personal care devices for grooming hair. More particularly, the invention relates to hair curlers and devices for heating hair curlers.

10

#### 2. Description of the Prior Art

Hair setting and curling devices are well known that include means for heating hair rollers to a selected temperature for use in the curling or setting of a woman's hair. These devices usually comprise a casing that has supports for detachably holding and heating hair rollers. When the rollers are heated to a desired temperature, they are removed from the supports. The user winds a cluster of hair around the outer surface of the heated roller and, as a result, the hair is more readily curled. The roller may be removed from the hair after only several minutes.

15  
20

An example of a hair roller as described above is shown in U.S. Patent No. 3,600,552 issued to Tolmie for Portable Electric Appliance. The Tolmie patent discloses a hair setting and curling means including hair roller means and heating apparatus therefor. The heating apparatus is provided in a casing and includes a heating plate having a plurality of spaced and parallel rail members. Hair rollers are provided that have grooves in one end adapted to be fitted over the rails thereby enabling heat to be conducted from the rail members to the rollers.

25  
30

These known devices present problems and inconveniences in use. The conventional heating apparatus transfers heat from a heating element to a heater case, then from the heater case to heater posts. This method



Fig. 3 is an exterior view of the hair curler of Fig. 1.

Fig. 4 is an exploded view of a preferred embodiment of a heater  
5 assembly for use with the hair curler of Fig. 1.

Fig. 5 is an exterior view of the hair curler of Fig. 1 placed upon the  
heater assembly of Fig. 4.

10

### Detailed Description of the Invention

Fig. 1 shows an exterior view of a preferred embodiment of the outer  
body, generally identified as 1, of a hair curler, that incorporates the  
15 present invention. Outer body 1 is divided into members 12a, 12b.  
Members 12a, 12b are preferably aluminum extrusions that have hollow  
regions 18a, 18b (see Fig. 2) defined by inner walls 14a, 14b (also see Fig.  
2) and outer walls 16a, 16b. Members 12a, 12b are spaced apart by an  
integral bridge 9. A slot 7 (see Fig. 3) is thereby formed in hair curler 1  
20 between inner walls 14a, 14b. Additionally, outer body 1 may be covered  
in a material, such as flocking, to enable outer body 1 to more easily grip  
hair wound upon it.

As seen in Fig. 2, an inner member 21 comprises an endpiece 23  
25 having a central opening 23a (see Fig. 3) through which endcap 24  
extends. Endcap 24 may be optionally opaque or translucent. Two,  
preferably hollow, columns 25a, 25b depend from endpiece 23. Columns  
25a, 25b of inner member 21 are positioned within respective hollow  
regions 18a, 18b of respective members 12a, 12b of outer body 1.

30

The exploded view of Figure 2 shows how the hair curler is  
preferably assembled. Outer body 1 is manufactured by extrusion as a  
hollow body having inner walls 14a, 14b and outerwalls 16a, 16b. A

portion 26 of outer body 1 is cut between inner walls 14a, 14b to thereby create bridge 9 and slot 7 (see Fig. 3). Optionally, a heat pipe 26 is placed in contact with bridge 9 and a thermochromic plug 28 is placed upon heat pipe 26 so as to be visible through optionally translucent endcap 24.

- 5 Columns 25a, 25b of inner body 21 are inserted into respective hollow regions 18a, 18b of respective members 12a, 12b of outer body 1. Finally, end caps 27a, 27b are connected to respective columns 25a, 25b.

Heater assembly 30 is shown in Figure 4. Heating element 33 is  
10 sandwiched between insulating layers 34a, 34b. Preferably, insulating layers 34a, 34b are mica. Sheath 36 is placed over insulating layers 34a, 34b. Sheath 36 is a heat conducting metal, most preferably, aluminum. Heater assembly 30 is proportioned to create an interference fit with inner walls 14a, 14b of hair curler 1.

15

In operation, as shown in Fig. 5, outer body 1 is disposed upon heater assembly 30 by placing slot 7 over sheath 36. Heating element 33 of heater assembly 30 transfers heat energy through insulating boards 34a, 34b into sheath 36. Sheath 36 transfers the heat energy to inner  
20 walls 14a, 14b of hair curler 1 and also heats the air enclosed within hollow regions 18a, 18b. Inner walls 14a, 14b transfer the heat energy to outer walls 16a, 16b. Inner walls 14a, 14b also transfer the heat energy through heat pipe 26 to thermochromic plug 28. Thermochromic plug 28 changes color at a given temperature so as to notify the user that outer body 1 is  
25 ready to be used.

The invention having been thus described with particular reference to the preferred form thereof, it will be obvious that various changes and modifications may be made therein without departing from the spirit and  
30 scope of the invention as defined in the appended claims.

What we claim is:

1. A hair curler comprising:
  - 5 a pair of substantially semi-cylindrical metal members having opposed, substantially planar side faces joined at one end by a bridge, said bridge separating said side faces by a distance  $d$ , said distance  $d$  creating a slot that is adapted to receive a rail-like heat conductor having a width  $w$ .
  - 10
  2. The hair curler according to claim 1 wherein said distance  $d$  is less than said width  $w$  of said rail-like heat conductor, thereby creating a contact fit between said side faces members and said rail-like heat conductor.
  - 15
  3. The hair curler according to claim 1 wherein said metal members are formed by extrusion and said bridge is an integral part thereof.
  4. The hair curler according to claim 1 wherein said metal members are hollow.
  - 20
  5. The hair curler according to claim 1 wherein substantially the entire surface areas of said opposed side faces are adapted to contact said rail-like heat conductor.
  - 25
  6. The hair curler according to claim 1 wherein said slot is of inverted U-shaped configuration and said rail-like heat conductor is similarly configured in cross section.
  - 30
  7. A hair curler comprising:
    - a substantially cylindrical hollow metal body,

said hollow metal body being partitioned into three sections by a pair of inner planar walls;

5           said metal body comprising a pair of substantially semi-cylindrical, hollow, metal members having opposed side faces joined at one end by a bridge integral thereto, said bridge formed by a cut in the material joining said hollow metal members, said cut creating a slot adapted to receive a rail-like heat conductor.

10   8.     The hair curler according to claim 7 wherein said hollow metal body is aluminum.

9.     The hair curler according to claim 7 wherein said hollow metal body is covered with flocking.

15

10.    The hair curler according to claim 7 further comprising means for signalling that said hair curler is ready to use.

20   11.   The hair curler according to claim 9, wherein said means for signalling is a thermochromic plug.

## AMENDED CLAIMS

[received by the International Bureau on 18 October 2000 (18.10.00); original claims 2-11 replaced by amended claims 2-11; remaining claim unchanged (2 pages)]

1. A hair curler comprising:

a pair of substantially semi-cylindrical metal members having opposed, substantially planar side faces joined at one end by a bridge, said bridge separating said side faces by a distance  $d$ , said distance  $d$  creating a slot that is adapted to receive a rail-like heat conductor having a width  $w$ .
2. The hair curler according to claim 1, wherein said distance  $d$  is less than said width  $w$  of said rail-like heat conductor, thereby creating an interference fit between said opposed side faces and said rail-like heat conductor.
3. The hair curler according to claim 1, wherein said metal members are formed by extrusion and said bridge is an integral part thereof.
4. The hair curler according to claim 1, wherein said metal members are hollow.
5. The hair curler according to claim 1, wherein substantially the entire surface areas of said opposed side faces are adapted to contact said rail-like heat conductor.
6. The hair curler according to claim 1, wherein said slot has an inverted U-shaped configuration and said rail-like heat conductor is similarly configured in cross section.
7. A hair curler comprising:

a substantially cylindrical hollow metal body, said metal body being partitioned into three sections by a pair of inner planar walls, said metal

body comprising a pair of substantially semi-cylindrical, hollow, metal members having opposed side faces joined at one end by a bridge integral thereto, said bridge formed by a cut in the material joining said hollow metal members, said cut creating a slot adapted to receive a rail-like heat conductor.

8. The hair curler according to claim 7, wherein said hollow metal body is aluminum.
9. The hair curler according to claim 7, wherein said hollow metal body is covered with flocking.
10. The hair curler according to claim 7, further comprising means for signaling that said hair curler is ready to use.
11. The hair curler according to claim 10, wherein said means for signaling is a thermochromic plug.

**FIG. 1.**

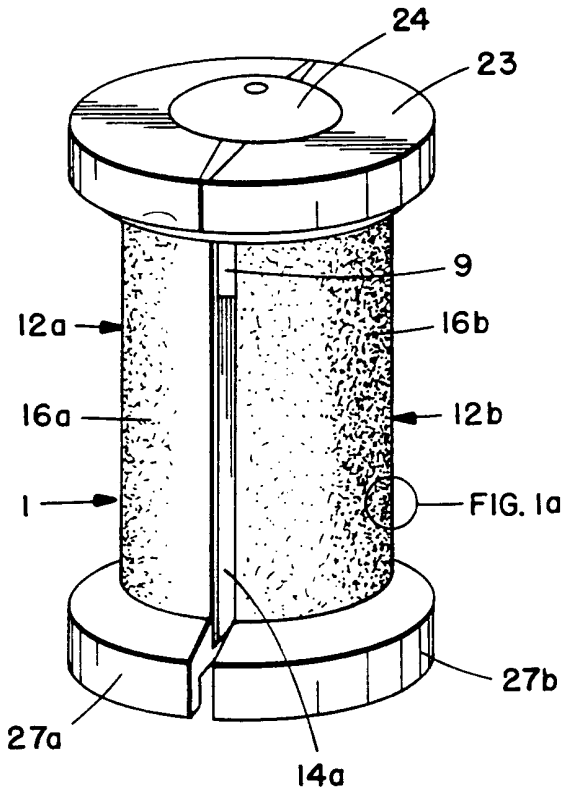

**FIG. 2.**

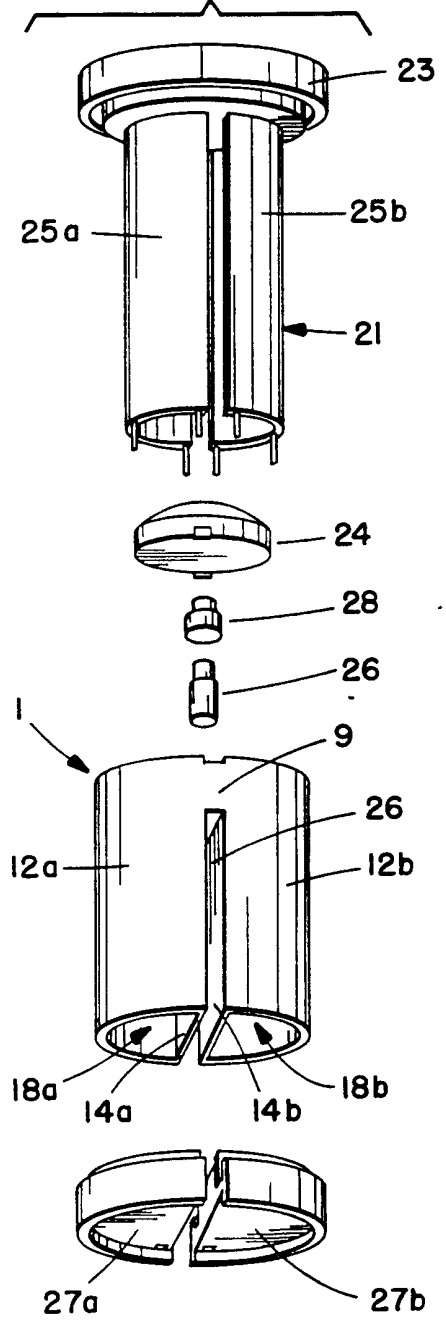

**FIG. 3.**

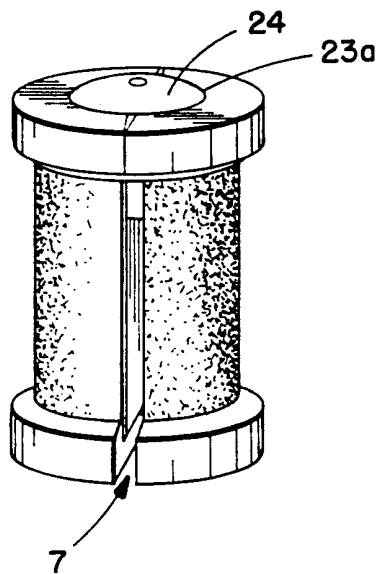

**FIG. 1a.**

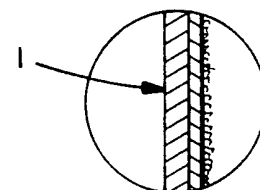

**FIG. 4.**

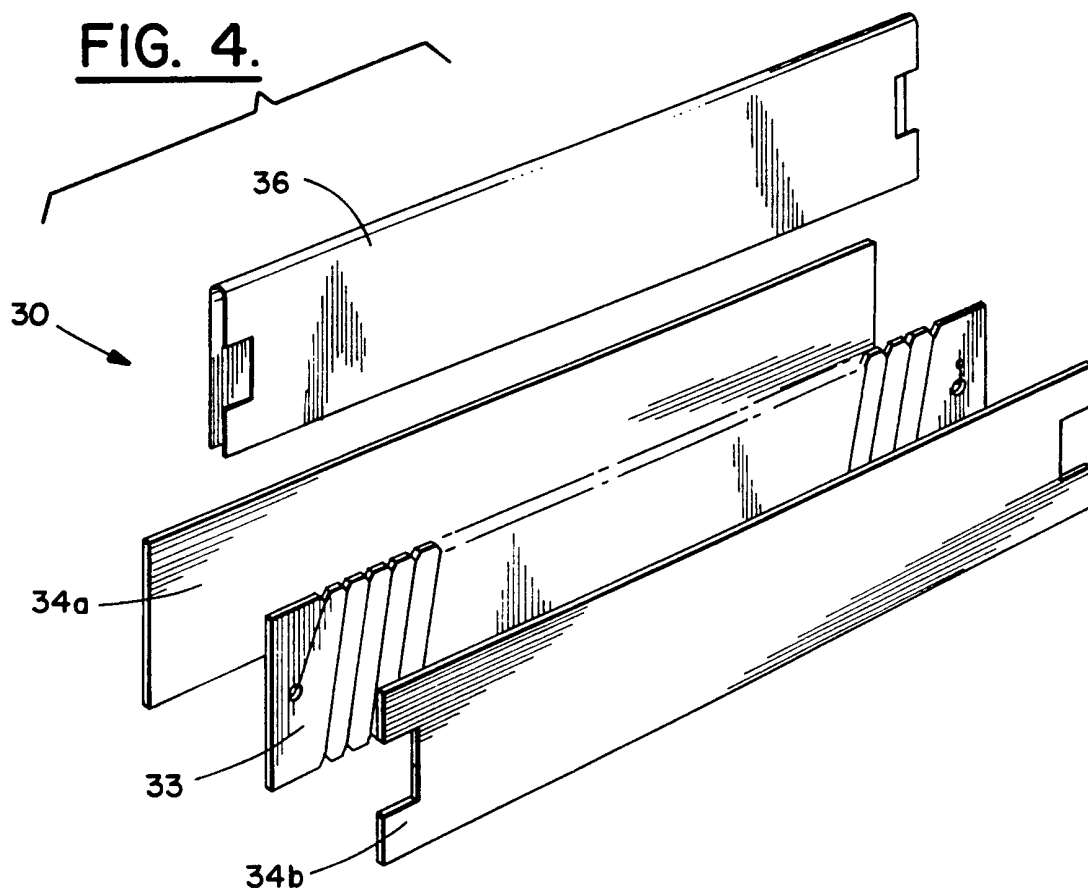

**FIG. 5.**

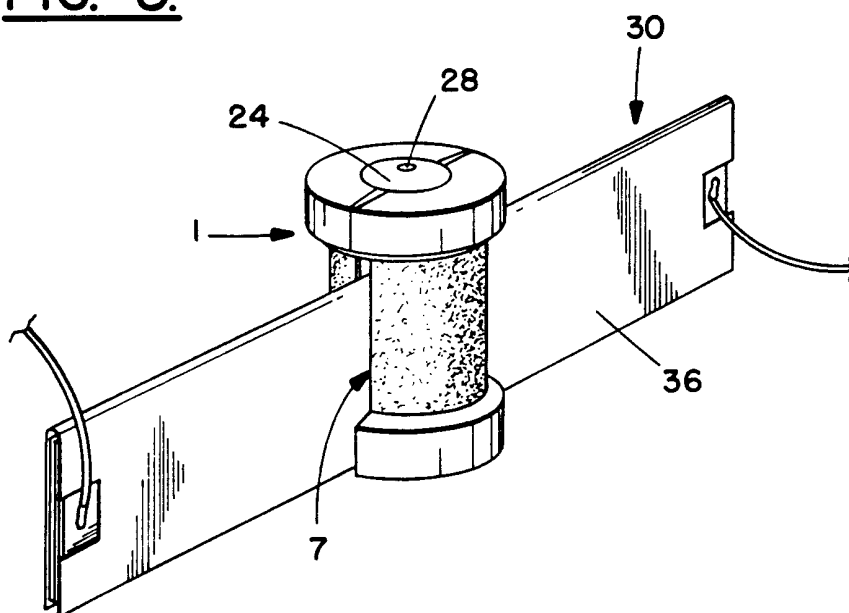

INTERNATIONAL SEARCH REPORT

International application No.  
PCT/US00/12134

**A. CLASSIFICATION OF SUBJECT MATTER**

IPC(7) :A45D 6/00  
US CL :219/222; 132/229

According to International Patent Classification (IPC) or to both national classification and IPC

**B. FIELDS SEARCHED**

Minimum documentation searched (classification system followed by classification symbols)

U.S. : 219/222, 225, 226; 132/229, 226, 233, 245, 234

Documentation searched other than minimum documentation to the extent that such documents are included in the fields searched

Electronic data base consulted during the international search (name of data base and, where practicable, search terms used)

**C. DOCUMENTS CONSIDERED TO BE RELEVANT**

Category*	Citation of document, with indication, where appropriate, of the relevant passages	Relevant to claim No.
Y	US 1,972,186 A (DAVIS) 04 September 1934, see Fig. 5.	1, 2, 5, 6
A	US 5,280,795 A (LEVEQUE ET AL) 25 January 1994, see Figs. 1a-3.	1-11
A	US 2,491,939 A (TASHO) 20 December 1949, see Fig. 1 and 2.	1-11
A	US 3,049,131 A (LECLABART) 14 August 1962, Fig. 1.	1-11
A	GB 280,909 A (BJORKMAN) 05 April 1928, Fig. 4.	1-11

Further documents are listed in the continuation of Box C.  See patent family annex.

* Special categories of cited documents:	*T* later document published after the international filing date or priority date and not in conflict with the application but cited to understand the principle or theory underlying the invention
*A* document defining the general state of the art which is not considered to be of particular relevance	*X* document of particular relevance; the claimed invention cannot be considered novel or cannot be considered to involve an inventive step when the document is taken alone
*E* earlier document published on or after the international filing date	*Y* document of particular relevance; the claimed invention cannot be considered to involve an inventive step when the document is combined with one or more other such documents, such combination being obvious to a person skilled in the art
*L* document which may throw doubts on priority claim(s) or which is cited to establish the publication date of another citation or other special reason (as specified)	*Z* document member of the same patent family
*O* document referring to an oral disclosure, use, exhibition or other means	
*P* document published prior to the international filing date but later than the priority date claimed	

Date of the actual completion of the international search

07 JULY 2000

Date of mailing of the international search report

30 AUG 2000

Name and mailing address of the ISA/US  
Commissioner of Patents and Trademarks  
Box PCT  
Washington, D.C. 20231

Facsimile No. (703) 305-3230

Authorized officer

JOHN A. JEFFERY

Telephone No. (703) 308-0858