



(86) Date de dépôt PCT/PCT Filing Date: 2011/08/18
 (87) Date publication PCT/PCT Publication Date: 2012/02/23
 (85) Entrée phase nationale/National Entry: 2013/02/15
 (86) N° demande PCT/PCT Application No.: US 2011/048259
 (87) N° publication PCT/PCT Publication No.: 2012/024493
 (30) Priorité/Priority: 2010/08/20 (US61/375,504)

(51) Cl.Int./Int.Cl. *A61M 1/12* (2006.01),
F04D 13/06 (2006.01), *F04D 29/048* (2006.01)
 (71) Demandeur/Applicant:
THORATEC CORPORATION, US
 (72) Inventeur/Inventor:
BOURQUE, KEVIN, US
 (74) Agent: SMART & BIGGAR

(54) Titre : POMPE SANGUINE IMPLANTABLE
 (54) Title: IMPLANTABLE BLOOD PUMP

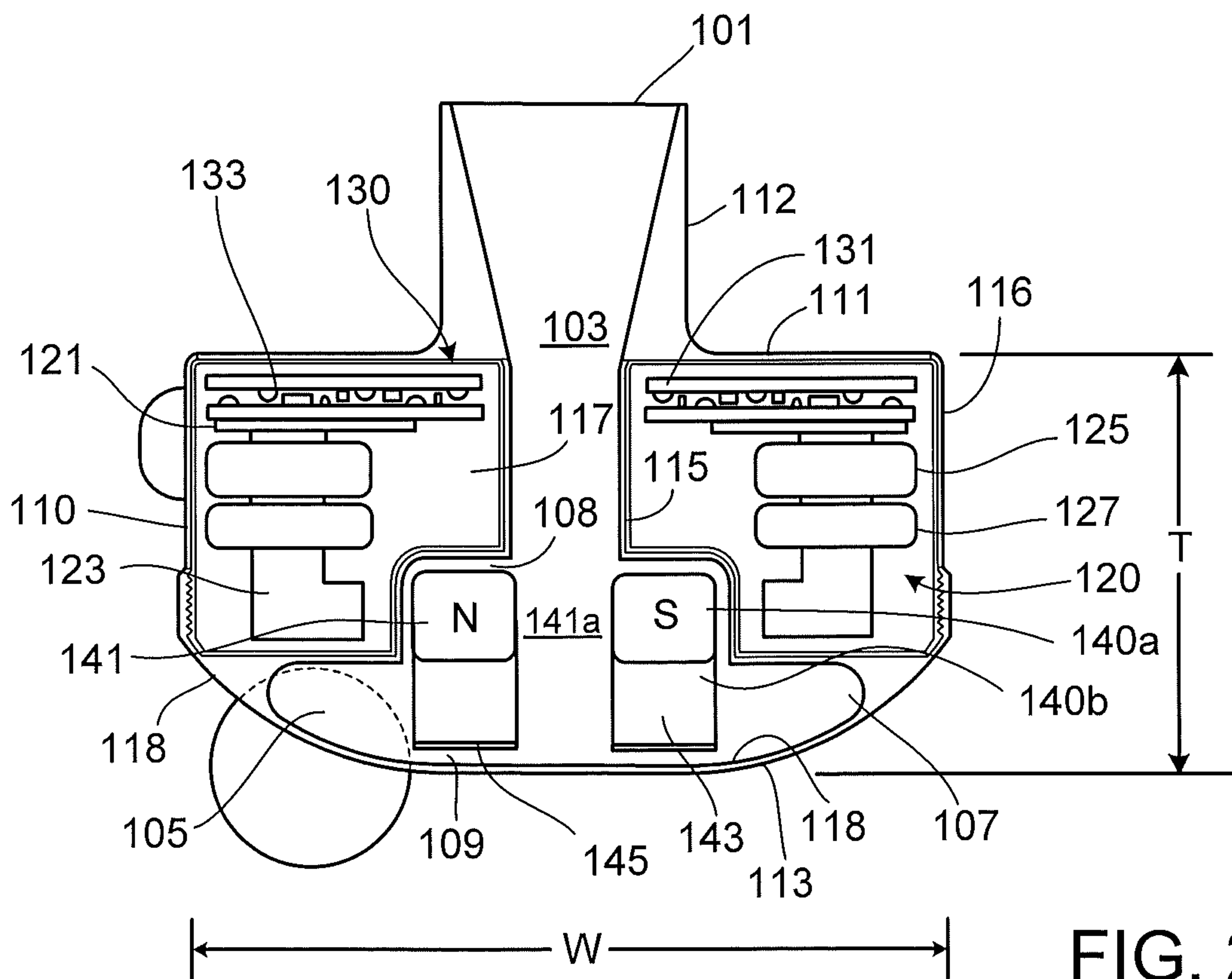

FIG. 2

(57) **Abrégé/Abstract:**

An implantable blood pump includes a housing defining an inlet opening and an outlet opening. Within the housing, a dividing wall defines a blood flow conduit extending between the inlet opening and the outlet opening of the housing. The blood pump has a rotary motor that includes a stator and a rotor. The stator is disposed within the housing circumferentially about the dividing wall such that the inner blood flow conduit extends through the stator.



WO 2012/024493 A1 

- *before the expiration of the time limit for amending the claims and to be republished in the event of receipt of amendments (Rule 48.2(h))*

IMPLANTABLE BLOOD PUMP

CROSS-REFERENCE TO RELATED APPLICATION

This application claims priority to and the full benefit of United States Provisional
5 Application Serial Number 61/375,504, filed August 20, 2010, and titled "Implantable Blood
Pump," the entire contents of which are incorporated herein by reference.

FIELD

This description relates to implantable blood pumps.

10

BACKGROUND

Ventricular assist devices, known as VADs, are implantable blood pumps used for
both short-term and long-term applications where a patient's heart is incapable of providing
adequate circulation. For example, a patient suffering from heart failure may use a VAD
15 while awaiting a heart transplant. In another example, a patient may use a VAD while
recovering from heart surgery. Thus, a VAD can supplement a weak heart or can effectively
replace the natural heart's function. VADs can be implanted in the patient's body and
powered by an electrical power source outside the patient's body.

20

SUMMARY

In one general aspect, an implantable blood pump includes a housing and a blood
flow conduit. Within the housing, the blood pump includes a stator located about the blood
flow conduit and a magnetically-controlled rotor.

In another general aspect, an implantable blood pump includes a housing defining an
25 inlet opening and an outlet opening. Within the housing, a dividing wall defines a blood flow
conduit extending between the inlet opening and the outlet opening of the housing. The
blood pump has a rotary motor that includes a stator and a rotor. The stator is disposed
within the housing circumferentially about the dividing wall such that the inner blood flow
conduit extends through the stator.

In another general aspect, an implantable blood pump includes a puck-shaped housing having a first face defining an inlet opening, a peripheral sidewall, and a second face opposing the first face. The blood pump has an internal dividing wall defining an inner blood flow conduit extending between the inlet opening and an outlet opening of the housing. The puck-shaped housing has a thickness from the first face to the second face that is less than a width of the housing between opposing portions of the peripheral sidewall. The blood pump also has a motor having a stator and a rotor. The stator is disposed in the housing circumferentially about the blood flow conduit and includes magnetic levitation components operable to control an axial position and a radial position of the rotor. The rotor is disposed in the inner blood flow conduit and includes an impeller operable to pump blood from the inlet opening to the outlet opening through at least a portion of the magnetic levitation components of the stator.

Implementations of the above aspects may include one or more of the following features. For example, the stator is disposed circumferentially about at least a part of the rotor and is positioned relative to the rotor such that in use blood flows within the blood flow conduit through the stator before reaching the rotor. The rotor has permanent magnetic poles for magnetic levitation of the rotor. A passive magnetic control system is configured to control an axial position of the rotor relative to the stator, and an active electromagnetic control system is configured to radially center the rotor within the inner blood flow conduit. An electromagnetic control system controls at least one of a radial position and an axial position of the rotor relative to the stator, and the electromagnetic control system has control electronics located within the housing about the dividing wall.

The control electronics are located between the inlet opening and the stator. The control electronics can be configured to control the active magnetic control system. The rotor has only one magnetic moment. The stator includes a first coil for driving the rotor and a second coil for controlling a radial position of the rotor, and the first coil and the second coil are wound around a first pole piece of the stator. The housing has a first face that defines the inlet opening, a second face opposing the first face, and a peripheral wall extending from the first face to the second face. The housing includes a rounded transition from the second face to the peripheral wall. The housing defines a volute located such that in use blood flows within the blood flow conduit through the stator before reaching the volute. The volute can be located between the stator and the second face. The housing can also include a cap that includes the second face, defines at least part of the volute, and defines at least part of the

outlet. The cap is engaged with the peripheral wall of the housing. The housing also includes an inlet cannula extending from the first face and in fluid communication with the inlet opening. The inlet cannula can be inserted into the patient's heart. The outlet opening is defined in the second face and/or the peripheral wall. A thickness of the housing between
5 the first face and the second face is less than a width of the housing.

In another general aspect, a method includes inserting a puck-shaped blood pump housing into a patient's body. The blood pump is inserted such that an opening defined in a first flat face of the housing that is proximate to a stator of the blood pump faces the patient's heart. Additionally, the blood pump is inserted such that a second rounded face of the
10 housing that is proximate to an impeller of the blood pump faces away from the patient's heart. The first face is disposed against a portion of the patient's heart such that the second face of the housing faces away from the heart of the patient. In some implementations, the method includes inserting an inlet cannula of the housing into the patient's heart.

In another general aspect, making a blood pump includes assembling a motor stator
15 and control electronics in a puck-shaped housing circumferentially about an internal dividing wall. The internal dividing wall defines an inner blood flow conduit that extends from an inlet opening to an outlet opening of the housing. The stator is assembled in the housing such that the inner blood flow conduit extends through the motor stator. Disposed within the inner blood flow conduit is a magnetically-levitated rotor. The rotor is surrounded by the stator
20 such that impeller blades carried by the rotor are downstream of the stator from the inlet opening. In use, the impeller pumps blood from the inlet opening to the outlet opening through the stator.

Implementations may include one or more of the following features. For example, the rotor has only one magnetic moment. The stator includes at least one first coil for driving the
25 rotor and at least one second coil for controlling a radial position of the rotor, the at least one first coil and the at least one second coil being wound around a first pole piece of the stator. The housing includes a first face that defines the inlet opening, and further comprising engaging an end cap with a peripheral wall of the housing, the end cap including a second face, defining at least part of a volute, and defining at least part of the outlet opening. The
30 housing includes a rounded transition from the second face to the peripheral wall. The housing further includes an inlet cannula extending from the first face and in fluid communication with the inlet opening. A thickness of the housing between the first face and the second face is less than a width of the housing.

In another general aspect, a method of pumping blood includes magnetically rotating a centrifugal pump impeller of a blood pump device to draw blood from a patient's heart through an inlet opening of a housing of the blood pump device into an inner blood flow conduit within a stator in the housing, through the inner blood flow conduit, and through an outlet opening of the housing. The method includes selectively controlling a radial position of the impeller within the inner blood flow conduit.

The details of one or more implementations are set forth in the accompanying drawings and the description below. Other features will be apparent from the description and drawings, and from the claims.

10

DESCRIPTION OF THE DRAWINGS

FIG. 1 is an illustration of a blood pump in a use position implanted in a patient's body.

FIG. 2 is a cross-sectional view of the blood pump of FIG. 1.

15 FIG. 3 is a partial cut-away perspective view of a stator of a blood pump.

FIG. 4 is a bottom perspective view of a blood pump.

FIG. 5 is a top perspective view of the blood pump of FIG. 4.

FIG. 6 is a front view of the blood pump of FIG. 4.

FIG. 7 is a back view of the blood pump of FIG. 4.

20 FIG. 8 is a right side view of the blood pump of FIG. 4.

FIG. 9 is a left side view of the blood pump of FIG. 4.

FIG. 10 is a bottom view of the blood pump of FIG. 4.

FIG. 11 is a top view of the blood pump of FIG. 4.

25

DETAILED DESCRIPTION

With reference to Figs. 1 and 4-11, a left ventricular assist blood pump 100 having a puck-shaped housing 110 is implanted in a patient's body with a first face 111 of the housing 110 positioned against the patient's heart H and a second face 113 of the housing 110 facing away from the heart H. The first face 111 of the housing 110 includes an inlet cannula 112

extending into the left ventricle LV of the heart H. The second face 113 of the housing 110 has a chamfered edge 114 to avoid irritating other tissue that may come into contact with the blood pump 100, such as the patient's diaphragm. To construct the illustrated shape of the puck-shaped housing 110 in a compact form, a stator 120 and electronics 130 of the pump 100 are positioned on the inflow side of the housing toward first face 111, and a rotor 140 of the pump 100 is positioned along the second face 113. This positioning of the stator 120, electronics 130, and rotor 140 permits the edge 114 to be chamfered along the contour of the rotor 140, as illustrated in at least Figs. 2, 4, and 6-9, for example.

Referring to Figure 2, the blood pump 100 includes a dividing wall 115 within the housing 110 defining a blood flow conduit 103. The blood flow conduit 103 extends from an inlet opening 101 of the inlet cannula 112 through the stator 120 to an outlet opening 105 defined by the housing 110. The rotor 140 is positioned within the blood flow conduit 103. The stator 120 is disposed circumferentially about a first portion 140a of the rotor 140, for example about a permanent magnet 141. The stator 120 is also positioned relative to the rotor 140 such that, in use, blood flows within the blood flow conduit 103 through the stator 120 before reaching the rotor 140. The permanent magnet 141 has a permanent magnetic north pole N and a permanent magnetic south pole S for combined active and passive magnetic levitation of the rotor 140 and for rotation of the rotor 140. The rotor 140 also has a second portion 140b that includes impeller blades 143. The impeller blades 143 are located within a volute 107 of the blood flow conduit such that the impeller blades 143 are located proximate to the second face 113 of the housing 110.

The puck-shaped housing 110 further includes a peripheral wall 116 that extends between the first face 111 and a removable cap 118. As illustrated, the peripheral wall 116 is formed as a hollow circular cylinder having a width W between opposing portions of the peripheral wall 116. The housing 110 also has a thickness T between the first face 111 and the second face 113 that is less than the width W. The thickness T is from about 0.5 inches to about 1.5 inches, and the width W is from about 1 inch to about 4 inches. For example, the width W can be approximately 2 inches, and the thickness T can be approximately 1 inch.

The peripheral wall 116 encloses an internal compartment 117 that surrounds the dividing wall 115 and the blood flow conduit 103, with the stator 120 and the electronics 130 disposed in the internal compartment 117 about the dividing wall 115. The removable cap 118 includes the second face 113, the chamfered edge 114, and defines the outlet opening 105. The cap 118 can be threadably engaged with the peripheral wall 116 to seal the cap 118

in engagement with the peripheral wall 116. The cap 118 includes an inner surface 118a of the cap 118 that defines the volute 107 that is in fluid communication with the outlet opening 105.

5 Within the internal compartment 117, the electronics 130 are positioned adjacent to the first face 111 and the stator 120 is positioned adjacent to the electronics 130 on an opposite side of the electronics 130 from the first face 111. The electronics 130 include circuit boards 131 and various components 133 carried on the circuit boards 131 to control the operation of the pump 100 by controlling the electrical supply to the stator 120. The housing 110 is configured to receive the circuit boards 131 within the internal compartment 10 117 generally parallel to the first face 111 for efficient use of the space within the internal compartment 117. The circuit boards also extend radially-inward towards the dividing wall 115 and radially-outward towards the peripheral wall 116. For example, the internal compartment 117 is generally sized no larger than necessary to accommodate the circuit boards 131, and space for heat dissipation, material expansion, potting materials, and/or other 15 elements used in installing the circuit boards 131. Thus, the external shape of the housing 110 proximate the first face 111 generally fits the shape of the circuits boards 131 closely to provide external dimensions that are not much greater than the dimensions of the circuit boards 131.

20 With continued reference to Fig. 2 and with reference to Fig. 3, the stator 120 includes a back iron 121 and pole pieces 123a-123f arranged at intervals around the dividing wall 115. The back iron 121 extends around the dividing wall 115 and is formed as a generally flat disc of a ferromagnetic material, such as steel, in order to conduct magnetic flux. The back iron 121 is arranged beside the control electronics 130 and provides a base for the pole pieces 123a-123f.

25 Each of the pole piece 123a-123f is L-shaped and has a drive coil 125 for generating an electromagnetic field to rotate the rotor 140. For example, the pole piece 123a has a first leg 124a that contacts the back iron 121 and extends from the back iron 121 towards the second face 113. The pole piece 123a also has a second leg 124b that extends from the first leg 124a towards the dividing wall 115 proximate the location of the permanent magnet 141 30 of the rotor 140. Each of the pole pieces 123a-123f also has a levitation coil 127 for generating an electromagnetic field to control the radial position of the rotor 140.

Each of the drive coils 125 and the levitation coils 127 includes multiple windings of a conductor around the pole pieces 123a-123f. Particularly, each of the drive coils 125 is wound around two adjacent ones of the pole pieces 123, such as pole pieces 123d and 123e, and each levitation coil 127 is wound around a single pole piece. The drive coils 125 and the levitation coils 127 are wound around the first legs of the pole pieces 123, and magnetic flux generated by passing electrical current through the coils 125 and 127 during use is conducted through the first legs and the second legs of the pole pieces 123 and the back iron 121. The drive coils 125 and the levitation coils 127 of the stator 120 are arranged in opposing pairs and are controlled to drive the rotor and to radially levitate the rotor 140 by generating electromagnetic fields that interact with the permanent magnetic poles S and N of the permanent magnet 141. Because the stator 120 includes both the drive coils 125 and the levitation coils 127, only a single stator is needed to levitate the rotor 140 using only passive and active magnetic forces. The permanent magnet 141 in this configuration has only one magnetic moment and is formed from a monolithic permanent magnetic body 141. For example, the stator 120 can be controlled as discussed in U.S. Patent No. 6,351,048, the entire contents of which are incorporated herein by reference. The control electronics 130 and the stator 120 receive electrical power from a remote power supply via a cable 119 (Fig. 1).

The rotor 140 is arranged within the housing 110 such that its permanent magnet 141 is located upstream of impeller blades in a location closer to the inlet opening 100. The permanent magnet 141 is received within the blood flow conduit 103 proximate the second legs 124b of the pole pieces 123 to provide the passive axial centering force through interaction of the permanent magnet 141 and ferromagnetic material of the pole pieces 123. The permanent magnet 141 of the rotor 140 and the dividing wall 115 form a gap 108 between the permanent magnet 141 and the dividing wall 115 when the rotor 140 is centered within the dividing wall 115. The gap 108 may be from about 0.2 millimeters to about 2 millimeters. For example, the gap 108 is approximately 1 millimeter. The north permanent magnetic pole N and the south permanent magnetic pole S of the permanent magnet 141 provide a permanent magnetic attractive force between the rotor 140 and the stator 120 that acts as a passive axial centering force that tends to maintain the rotor 140 generally centered within the stator 120 and tends to resist the rotor 140 from moving towards the first face 111 or towards the second face 113. When the gap 108 is smaller, the magnetic attractive force between the permanent magnet 141 and the stator 120 is greater, and the gap 108 is sized to

allow the permanent magnet 141 to provide the passive magnetic axial centering force having a magnitude that is adequate to limit the rotor 140 from contacting the dividing wall 115 or the inner surface 118a of the cap 118. The rotor 140 also includes a shroud 145 that covers the ends of the impeller blades 143 facing the second face 113 that assists in directing blood flow into the volute 107. The shroud 145 and the inner surface 118a of the cap 118 form a gap 109 between the shroud 145 and the inner surface 118a when the rotor 140 is levitated by the stator 120. The gap 109 is from about 0.2 millimeters to about 2 millimeters. For example, the gap 109 is approximately 1 millimeter.

As blood flows through the blood flow conduit 103, blood flows through a central aperture 141a formed through the permanent magnet 141. Blood also flows through the gap 108 between the rotor 140 and the dividing wall 115 and through the gap 109 between the shroud 145 and the inner surface 108a of the cap 118. The gaps 108 and 109 are large enough to allow adequate blood flow to limit clot formation that may occur if the blood is allowed to become stagnant. The gaps 108 and 109 are also large enough to limit pressure forces on the blood cells such that the blood is not damaged when flowing through the pump 100. As a result of the size of the gaps 108 and 109 limiting pressure forces on the blood cells, the gaps 108 and 109 are too large to provide a meaningful hydrodynamic suspension effect. That is to say, the blood does not act as a bearing within the gaps 108 and 109, and the rotor is only magnetically-levitated.

Because the rotor 140 is radially suspended by active control of the levitation coils 127 as discussed above, and because the rotor 140 is axially suspended by passive interaction of the permanent magnet 141 and the stator 120, no rotor levitation components are needed proximate the second face 113. The incorporation of all the components for rotor levitation in the stator 120 (i.e., the levitation coils 127 and the pole pieces 123) allows the cap 118 to be contoured to the shape of the impeller blades 141 and the volute 107. Additionally, incorporation of all the rotor levitation components in the stator 120 eliminates the need for electrical connectors extending from the compartment 117 to the cap 118, which allows the cap to be easily installed and/or removed and eliminates potential sources of pump failure.

In use, the drive coils 125 of the stator 120 generates electromagnetic fields through the pole pieces 123 that selectively attract and repel the magnetic north pole N and the magnetic south pole S of the rotor 140 to cause the rotor 140 to rotate within stator 120. As the rotor 140 rotates, the impeller blades 143 force blood into the volute 107 such that blood is forced out of the outlet opening 105. Additionally, the rotor draws blood into pump 100

through the inlet opening 101. As blood is drawn into the blood pump by rotation of the impeller blades 143 of the rotor 140, the blood flows through the inlet opening 101 and flows through the control electronics 130 and the stator 120 toward the rotor 140. Blood flows through the aperture 141a of the permanent magnet 141 and between the impeller blades 143, the shroud 145, and the permanent magnet 141, and into the volute 107. Blood also flows around the rotor 140, through the gap 108 and through the gap 109 between the shroud 145 and the inner surface 118a of the cap 118. The blood exits the volute 107 through the outlet opening 105.

A number of implementations have been described. Nevertheless, it will be understood that various modifications may be made without departing from the spirit and scope of the claimed invention. For example, the cap 118 can be engaged with the peripheral wall 116 using a different attachment mechanism or technique, including snap-fit engagement, adhesives, or welding. Additionally, while the cap 118 has been described as defining the outlet opening 105 and the chamfered edge 114, the outlet opening 105 and/or the chamfered edge 114 can be defined by the peripheral wall 116 or by both the peripheral wall 116 and the cap 118. Similarly, the dividing wall 115 can be formed as part of the cap 118.

Additionally, the rotor 140 can include two or more permanent magnets. The number and configuration of the pole pieces 123 can also be varied. The operation of the control electronics 130 is selected to account for the number and position of pole pieces of the stator and permanent magnets of the rotor. Also, the cap 118 can be engaged with the peripheral wall using other techniques, such as adhesives, welding, snap-fit, shrink-fit, or other technique or structure. Similarly, the first face 111 may be formed from a separate piece of material than the peripheral wall 116 and the first face 111, including the inlet cannula 112, can be attached to the peripheral wall 116, such as by welding, after the control electronics 130 and the stator 120 have been mounted in the internal compartment 117. The shroud 145 may be omitted and optionally replaced by other flow control devices to achieve a desired pump efficiency. As another option, the control electronics 130 can be located external to the pump 100, such as in a separate housing implanted in the patient's abdomen, or external to the patient's body.

In some implementations, the dimensions of the housing 110 can be larger or smaller than those described above. Similarly, the ratio of the width W of the housing 110 to the thickness T of the housing can be different than the ratio described above. For example, the

width W can be from about 1.1 to about 5 times greater than the thickness T . Additionally, the permanent magnet 141 of the rotor 140 can include two or more pairs of north and south magnetic poles. While the peripheral wall 116 and the dividing wall 115 are illustrated as cylinders having circular cross-sectional shapes, one or both can alternatively be formed
5 having other cross-sectional shapes, such as oval, or an irregular shape. Similarly, the peripheral wall 116 can be tapered such that the housing does not have a constant width W from the first face 111 to the second face 113.

As mentioned above, in some implementations, the blood pump 100 can be used to assist a patient's heart during a transition period, such as during a recovery from illness
10 and/or surgery or other treatment. In other implementations, the blood pump 100 can be used to partially or completely replace the function of the patient's heart on a generally permanent basis, such as where the patient's aortic valve is surgically sealed.

Accordingly, other embodiments are within the scope of the following claims.

CLAIMS

1. An implantable blood pump comprising:
a housing defining an inlet opening and an outlet opening;
5 a dividing wall within the housing defining a blood flow conduit, the blood flow conduit extending between the inlet opening and the outlet opening of the housing; and
a rotary motor including a stator and a rotor, the stator being disposed within the housing circumferentially about the dividing wall such that the inner blood flow conduit extends through the stator.
10
2. The implantable blood pump of claim 1, wherein the stator is disposed circumferentially about at least a part of the rotor and is positioned relative to the rotor such that in use blood flows within the blood flow conduit through the stator before reaching the rotor.
15
3. The implantable blood pump of any preceding claim, wherein the rotor has permanent magnetic poles for magnetic levitation of the rotor.
4. The implantable blood pump of any preceding claim, further comprising control
20 electronics disposed within the housing about the dividing wall.
5. The implantable blood pump of claim 4, wherein the control electronics are located between the inlet opening and the stator.
- 25 6. The implantable blood pump of any preceding claim, wherein the rotor has only one magnetic moment.
7. The implantable blood pump of any preceding claim, wherein the stator includes a first coil for driving the rotor and a second coil for controlling a radial position of the rotor,
30 the first coil and the second coil being wound around a first pole piece of the stator.

8. The implantable blood pump of any preceding claim, wherein the housing defines a volute located such that in use blood flows within the blood flow conduit through the stator before reaching the volute.
- 5 9. The implantable blood pump of any preceding claim, wherein the housing has a first face that defines the inlet opening, a second face opposing the first face, and a peripheral wall extending from the first face to the second face, wherein the housing includes a rounded transition from the second face to the peripheral wall.
- 10 10. The implantable blood pump of claim 9, further comprising an inlet cannula extending from the first face and in fluid communication with the inlet opening.
11. The implantable blood pump of claim 9 or 10, wherein the outlet opening is defined in at least one of the second face and the peripheral wall.
- 15 12. The implantable blood pump of any of claims 9 to 11, wherein a thickness of the housing between the first face and the second face is less than a width of the housing.
13. The implantable blood pump of any preceding claim, further comprising:
20 a passive magnetic control system configured to control an axial position of the rotor relative to the stator; and
an active electromagnetic control system configured to radially center the rotor within the inner blood flow conduit.
- 25 14. The implantable blood pump of claim 12, further comprising control electronics configured to control the active electromagnetic control system disposed within the housing about the dividing wall.
- 30 15. The implantable blood pump of any preceding claim, comprising a magnetic control system for controlling at least one of a radial position and an axial position of the rotor relative to the stator.

16. The implantable blood pump of any preceding claim, wherein the housing is puck-shaped.
17. The implantable blood pump of any preceding claim, wherein the stator comprises
5 magnetic levitation components operable to control an axial position and a radial position of the rotor.
18. The implantable blood pump of claim 17, wherein the rotor is disposed in the inner
10 blood flow conduit and includes an impeller operable to pump blood from the inlet opening to the outlet opening through at least a portion of the magnetic levitation components of the stator.
19. An implantable blood pump comprising:
a housing defining an inlet opening and an outlet opening;
15 a dividing wall within the housing defining a blood flow conduit, the blood flow conduit extending between the inlet opening and an outlet opening of the housing;
a motor including a stator and a rotor, the stator being disposed within the housing circumferentially about the dividing wall such that the inner blood flow conduit extends through the stator;
20 a passive magnetic control system configured to control an axial position of the rotor relative to the stator; and
an active electromagnetic control system configured to radially center the rotor within the inner blood flow conduit.
20. The implantable blood pump of claim 19, further comprising control electronics
25 configured to control the active electromagnetic control system disposed within the housing about the dividing wall.
21. The implantable blood pump of claim 19 or 20, wherein the control electronics are
30 located between the inlet opening and the stator.
22. The implantable blood pump of any of claims 19 to 21, wherein the rotor has only one magnetic moment.

23. The implantable blood pump of any of claims 19 to 21, wherein the stator includes a first coil for driving the rotor and a second coil for controlling a radial position of the rotor, the first coil and the second coil being wound around a first pole piece of the stator.

5

24. The implantable blood pump of any of claims 19 to 21, wherein the housing further includes a first face that defines the inlet opening and a second face opposing the first face and a peripheral wall extending from the first face to the second face, wherein the housing includes a rounded transition from the second face to the peripheral wall.

10

25. The implantable blood pump of claim 24, further comprising an inlet cannula extending from the first face and in fluid communication with the inlet opening.

15

26. The implantable blood pump of claim 24 or 25, wherein the outlet opening is defined in at least one of the second face and the peripheral wall.

27. The implantable blood pump any of claims 24 to 26, wherein a thickness of the housing between the first face and the second face is less than a width of the housing.

20

28. An implantable blood pump comprising:

a housing defining an inlet opening and an outlet opening;

a dividing wall within the housing defining a blood flow conduit the blood flow conduit extending between the inlet opening and an outlet opening of the housing;

25

a motor having a stator and a rotor, the stator being located within the housing circumferentially about the dividing wall such that the inner blood flow conduit extends through the stator; and

a magnetic control system for controlling at least one of a radial position and an axial position of the rotor relative to the stator, the magnetic control system having control electronics located within the housing about the dividing wall.

30

29. The implantable blood pump of claim 28, wherein the rotor has only one magnetic moment.

30. The implantable blood pump of claim 28 or 29, wherein the stator includes a first coil for driving the rotor and a second coil for controlling a radial position of the rotor, the first coil and the second coil being wound around a first pole piece of the stator.

5 31. The implantable blood pump of any of claims 28 to 30, wherein the housing further includes a first face that defines the inlet opening, a second face opposing the first face, and a peripheral wall extending from the first face to the second face, wherein the housing includes a rounded transition from the second face to the peripheral wall.

10 32. The implantable blood pump of claim 31, further comprising an inlet cannula extending from the first face and in fluid communication with the inlet opening.

33. The implantable blood pump of claim 31 or 32, wherein the outlet opening is defined in at least one of the second face and the peripheral wall.

15

34. The implantable blood pump of any of claims 31 to 33, wherein a thickness of the housing between the first face and the second face is less than a width of the housing.

35. A method, comprising:

20

inserting a puck-shaped blood pump housing into a patient's body such that an opening defined in a first flat face of the housing that is proximate to a stator of the blood pump faces the patient's heart and such that a second rounded face of the housing that is proximate to an impeller of the blood pump faces away from the patient's heart; and

25

disposing the first face against a portion of the patient's heart such that the second face of the housing faces away from the heart to at least partially avoid irritation of other tissues of the patient that come into contact with the puck-shaped blood pump.

36. The method of claim 35, further comprising, inserting an inlet cannula of the housing into the patient's heart.

30

37. An implantable blood pump comprising:

a puck-shaped housing having a first face defining an inlet opening, a peripheral sidewall, a second face opposing the first face, and an internal dividing wall defining an inner

blood flow conduit, the inner blood flow conduit extending between the inlet opening and an outlet opening of the housing, wherein the puck-shaped housing has a thickness from the first face to the second face that is less than a width of the housing between opposing portions of the peripheral sidewall; and

5 a motor having a stator and a rotor, the stator being disposed in the housing circumferentially about the blood flow conduit and including magnetic levitation components operable to control an axial position and a radial position of the rotor, the rotor being disposed in the inner blood flow conduit and including an impeller operable to pump blood from the inlet opening to the outlet opening through at least a portion of the magnetic
10 levitation components of the stator.

38. The implantable blood pump of claim 37, further comprising control electronics disposed in the housing about the blood flow conduit.

15 39. The implantable blood pump of claim 37 or 38, wherein the rotor has only one magnetic moment.

40. The implantable blood pump of any of claims 37 to 39, wherein the stator includes at least one first coil for driving the rotor and at least one second coil for controlling a radial
20 position of the rotor, the at least one first coil and the at least one second coil being wound around a first pole piece of the stator.

41. The implantable blood pump of any of claims 37 to 40, wherein the housing defines a volute located between the rotor and the second face.

25 42. The implantable blood pump of any of claims 37 to 41, wherein the housing includes a rounded transition from the second face to the peripheral wall.

43. The implantable blood pump of any of claims 37 to 42, further comprising an inlet
30 cannula extending from the first face and in fluid communication with the inlet opening.

44. The implantable blood pump of any of claims 37 to 43, wherein the outlet opening is defined in at least one of the second face and the peripheral wall.

45. A method of making a blood pump, the method comprising:
assembling a motor stator and control electronics in a puck-shaped housing
circumferentially about an internal dividing wall, the internal dividing wall defining the an
5 inner blood flow conduit that extends from an inlet opening to an outlet opening of the
housing, the stator being assembled in the housing such that the inner blood flow conduit
extends through the motor stator; and
disposing a magnetically-levitated rotor within the inner blood flow conduit and
surrounded by the stator such that impeller blades carried by the rotor are downstream of the
10 rotor from the inlet opening, and such that, in use, the impeller pumps blood from the inlet
opening to the outlet opening through the stator.
46. The method of claim 45, wherein the rotor has only one magnetic moment.
- 15 47. The method of claim 45 or 46, wherein the stator includes at least one first coil for
driving the rotor and at least one second coil for controlling a radial position of the rotor, the
at least one first coil and the at least one second coil being wound around a first pole piece of
the stator.
- 20 48. The method of any of claims 45 to 47, wherein the housing includes a first face that
defines the inlet opening, and further comprising engaging an end cap with a peripheral wall
of the housing, the end cap including a second face, defining at least part of a volute, and
defining at least part of the outlet opening.
- 25 49. The method of claim 48, wherein the housing includes a rounded transition from the
second face to the peripheral wall.
50. The method of claim 48 or 49, wherein the housing further includes an inlet cannula
extending from the first face and in fluid communication with the inlet opening.
- 30 51. The method of any of claims 48 to 50, wherein a thickness of the housing between the
first face and the second face is less than a width of the housing.

52. A method of pumping blood, the method comprising:
- magnetically rotating a centrifugal pump impeller of a blood pump device to draw blood from a patient's heart through an inlet opening of a housing of the blood pump device into an inner blood flow conduit within a stator in the housing, through the inner blood flow
- 5 conduit, and through an outlet opening of the housing; and
- selectively controlling a radial position of the impeller within the inner blood flow conduit.

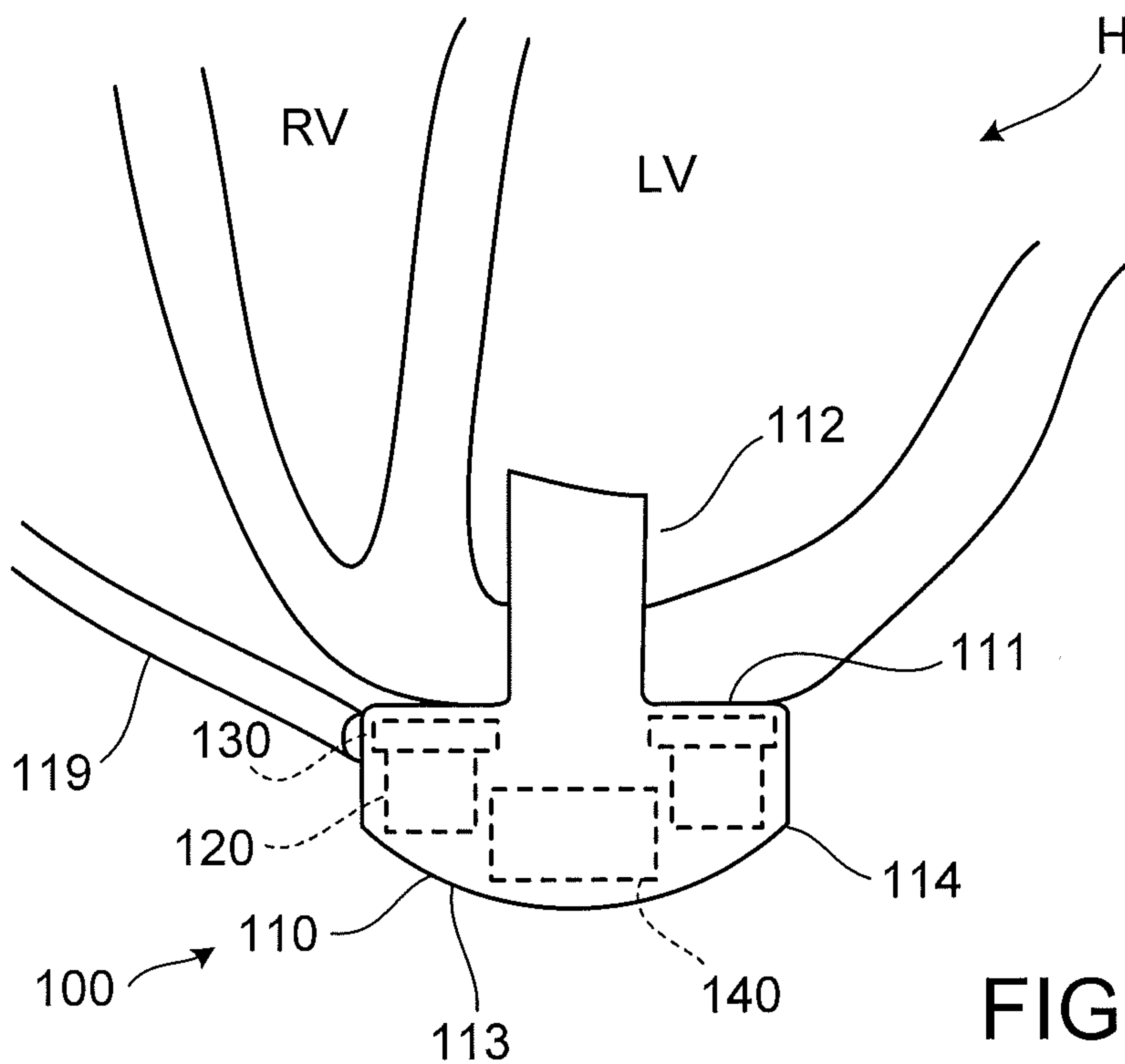

FIG. 1

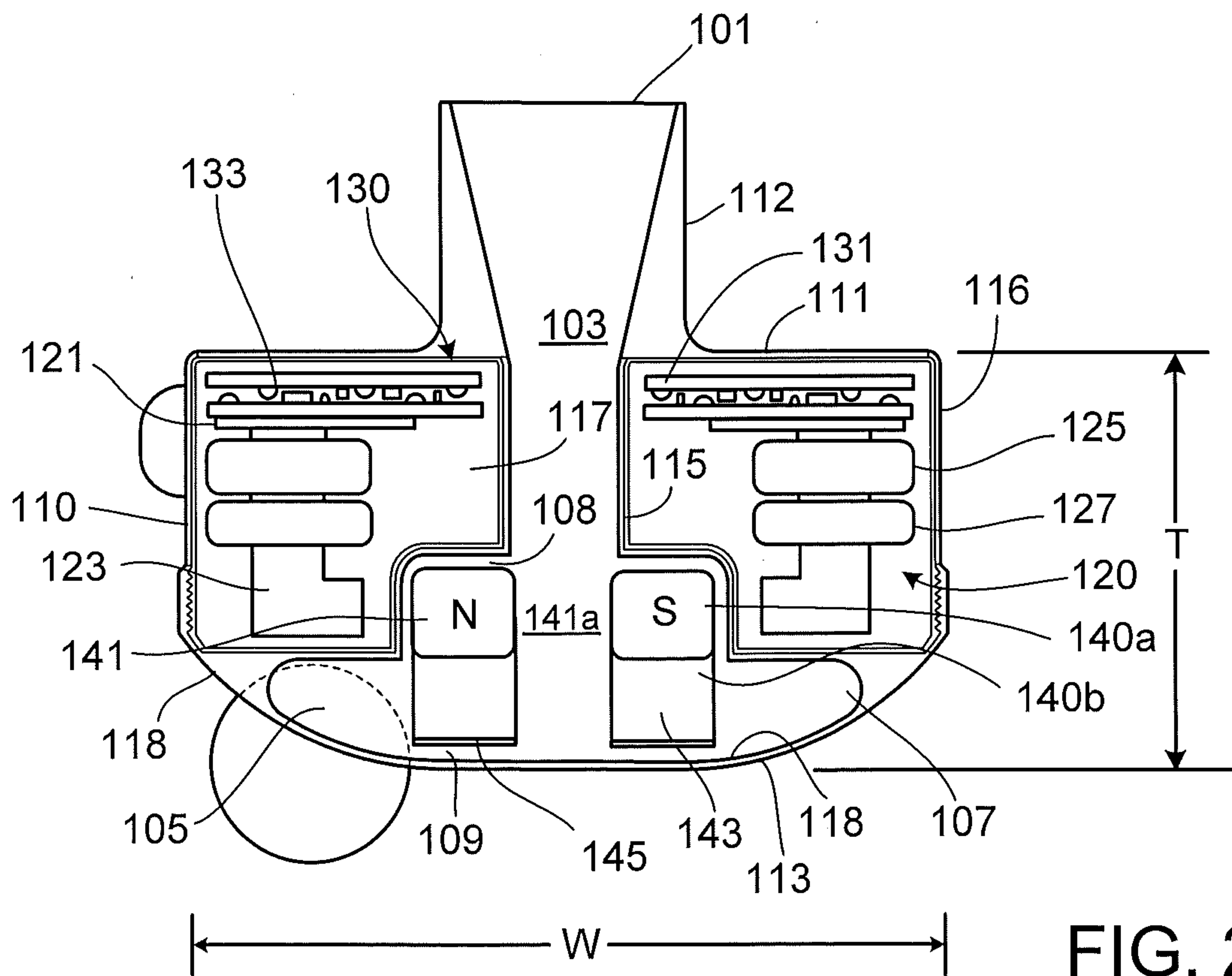

FIG. 2

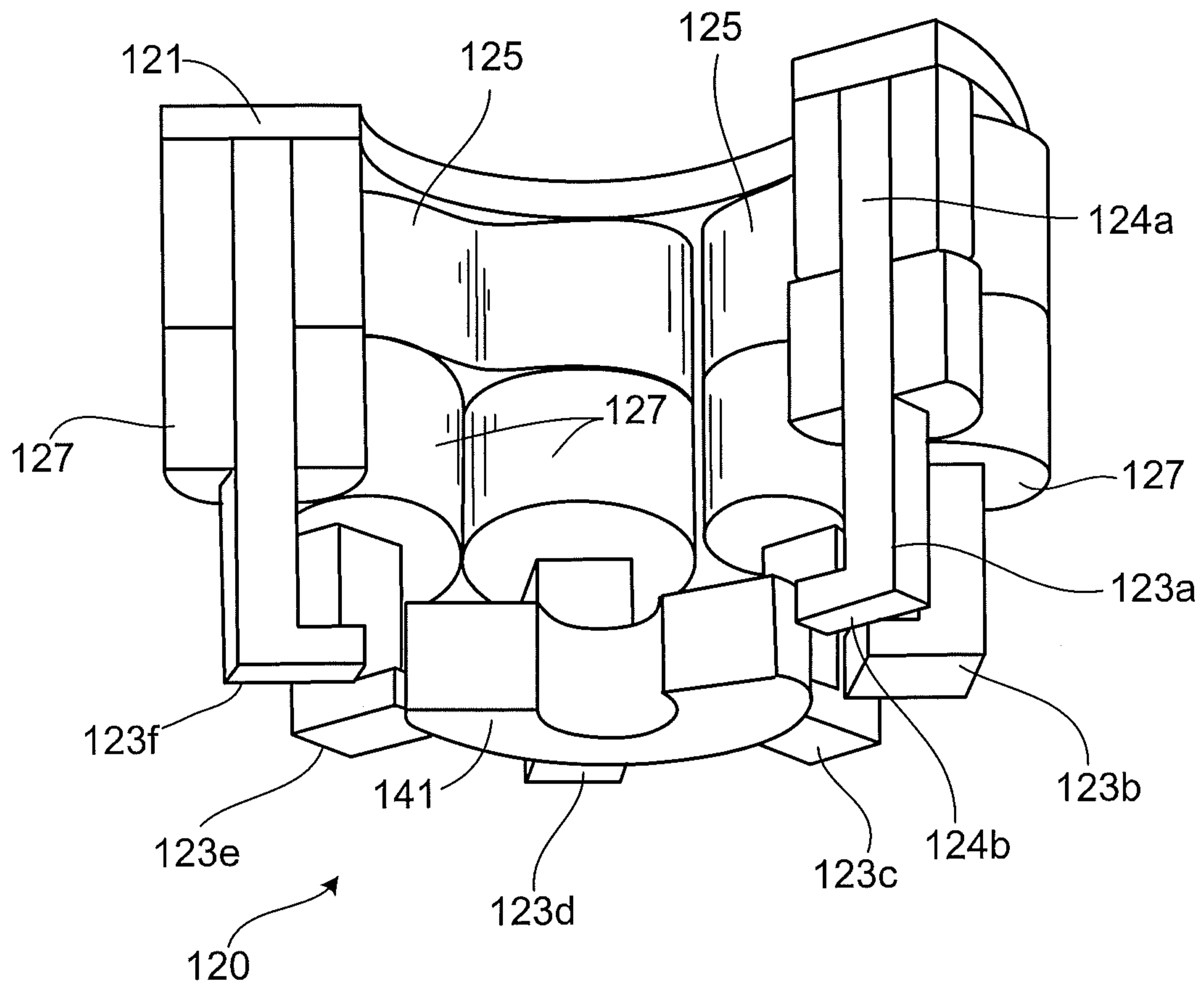

FIG. 3

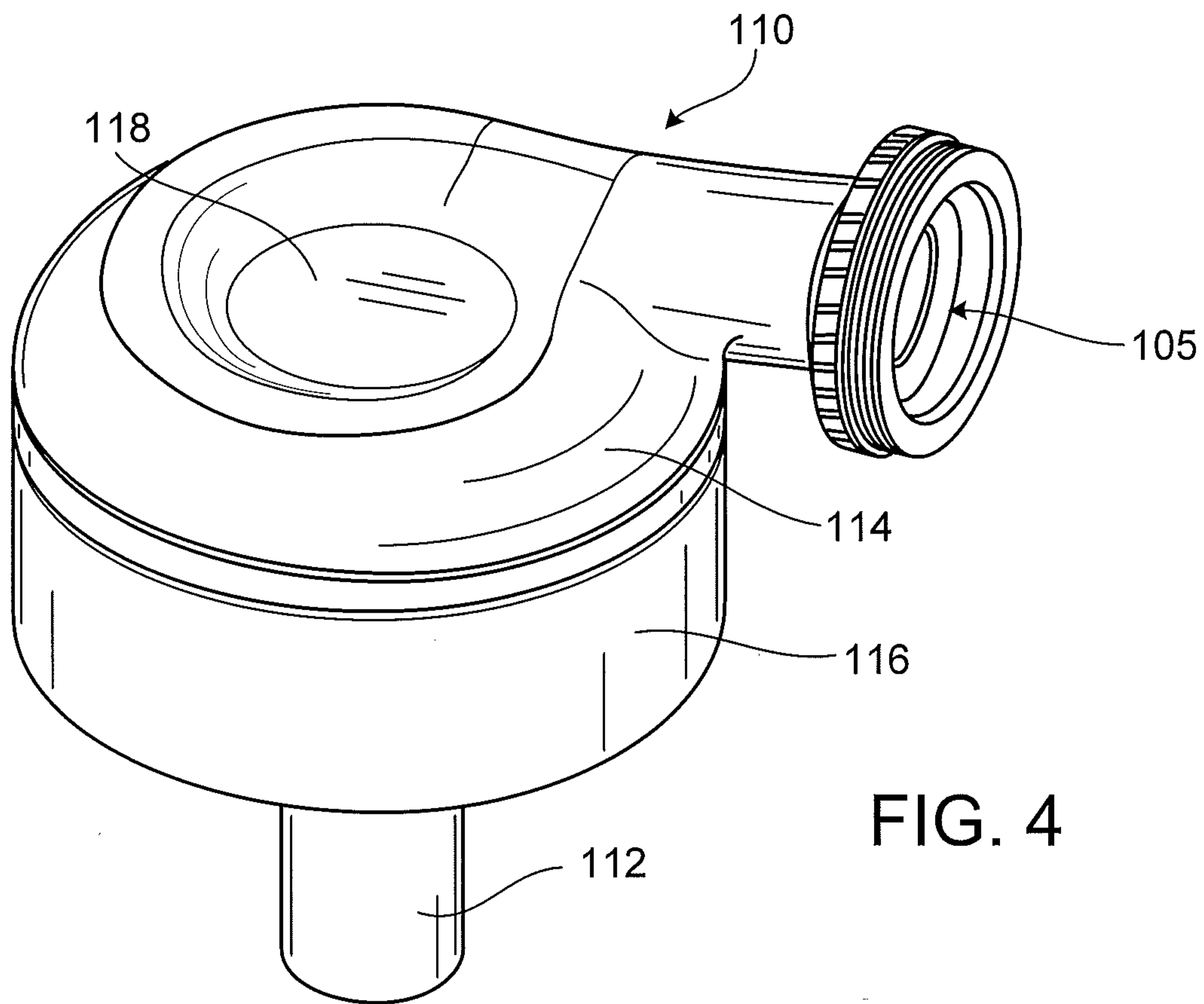

FIG. 4

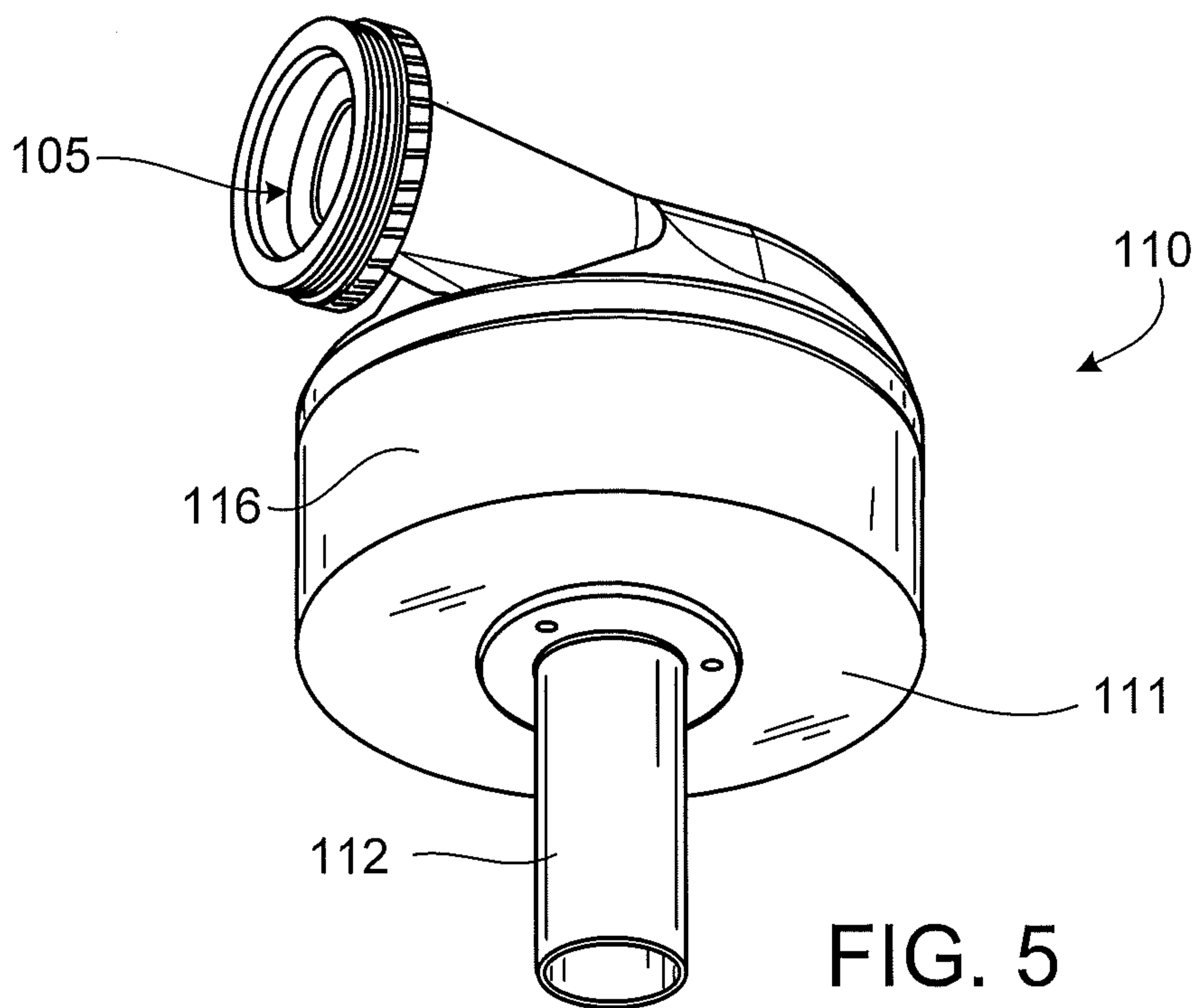

FIG. 5

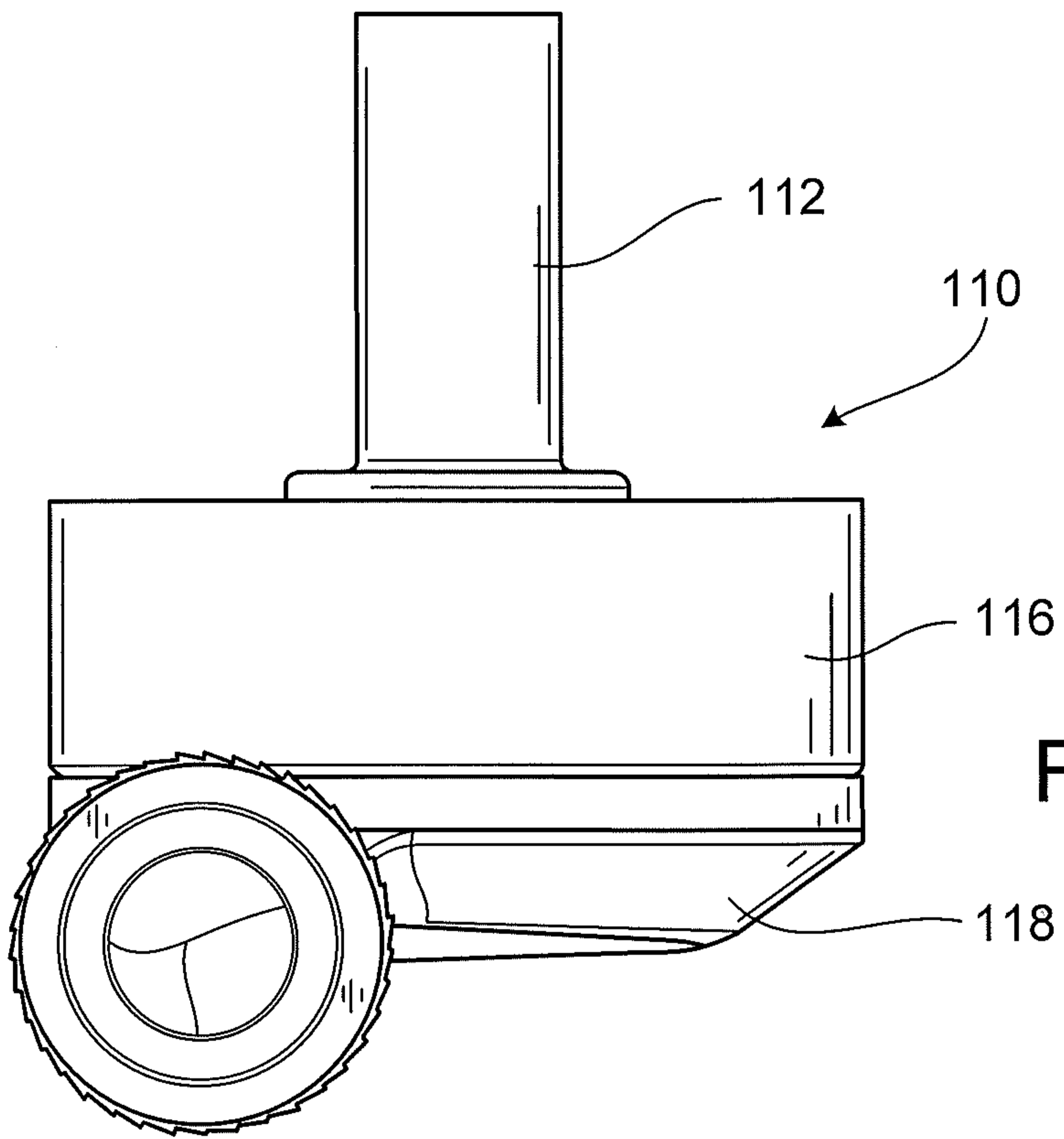

FIG. 6

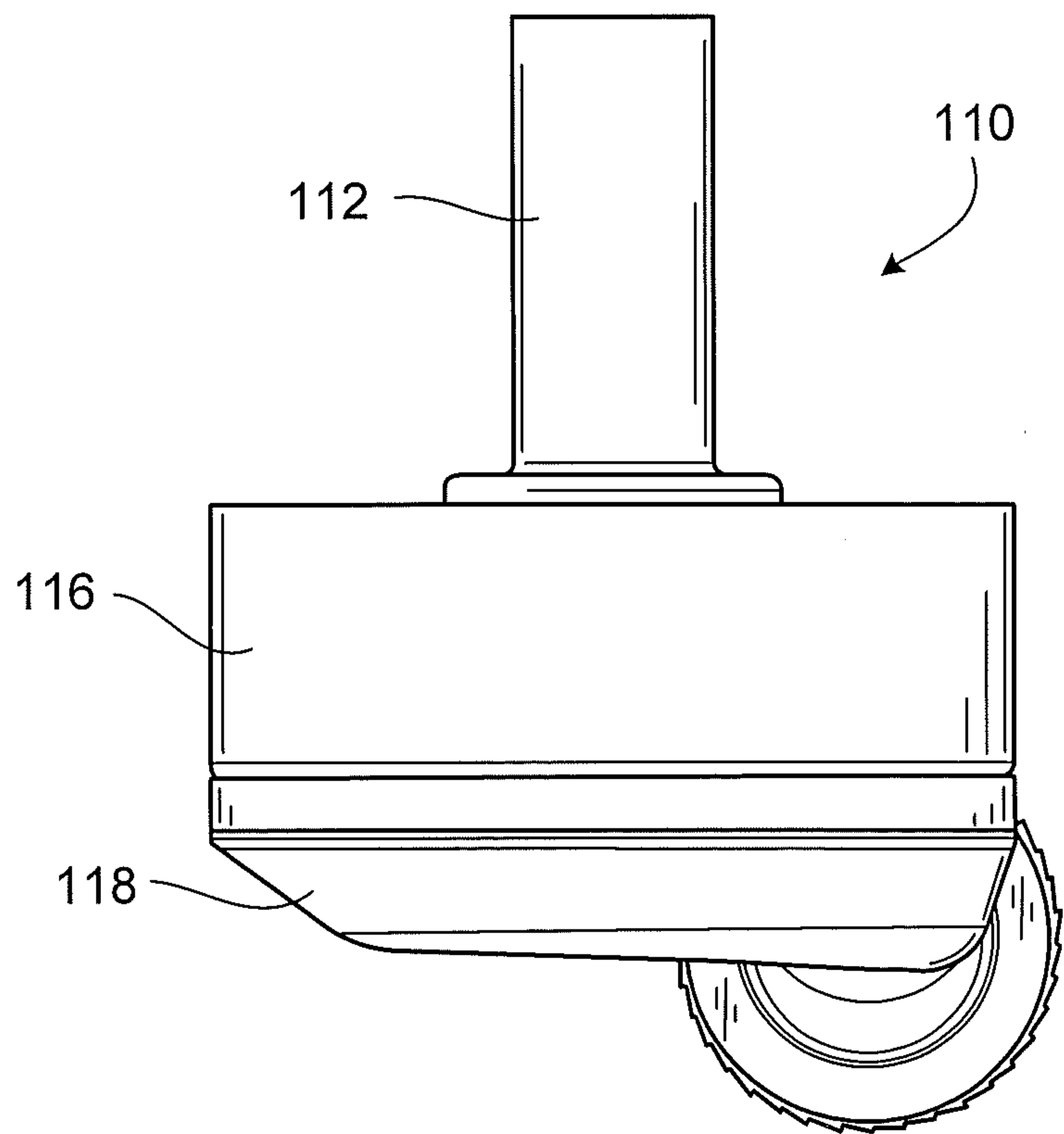
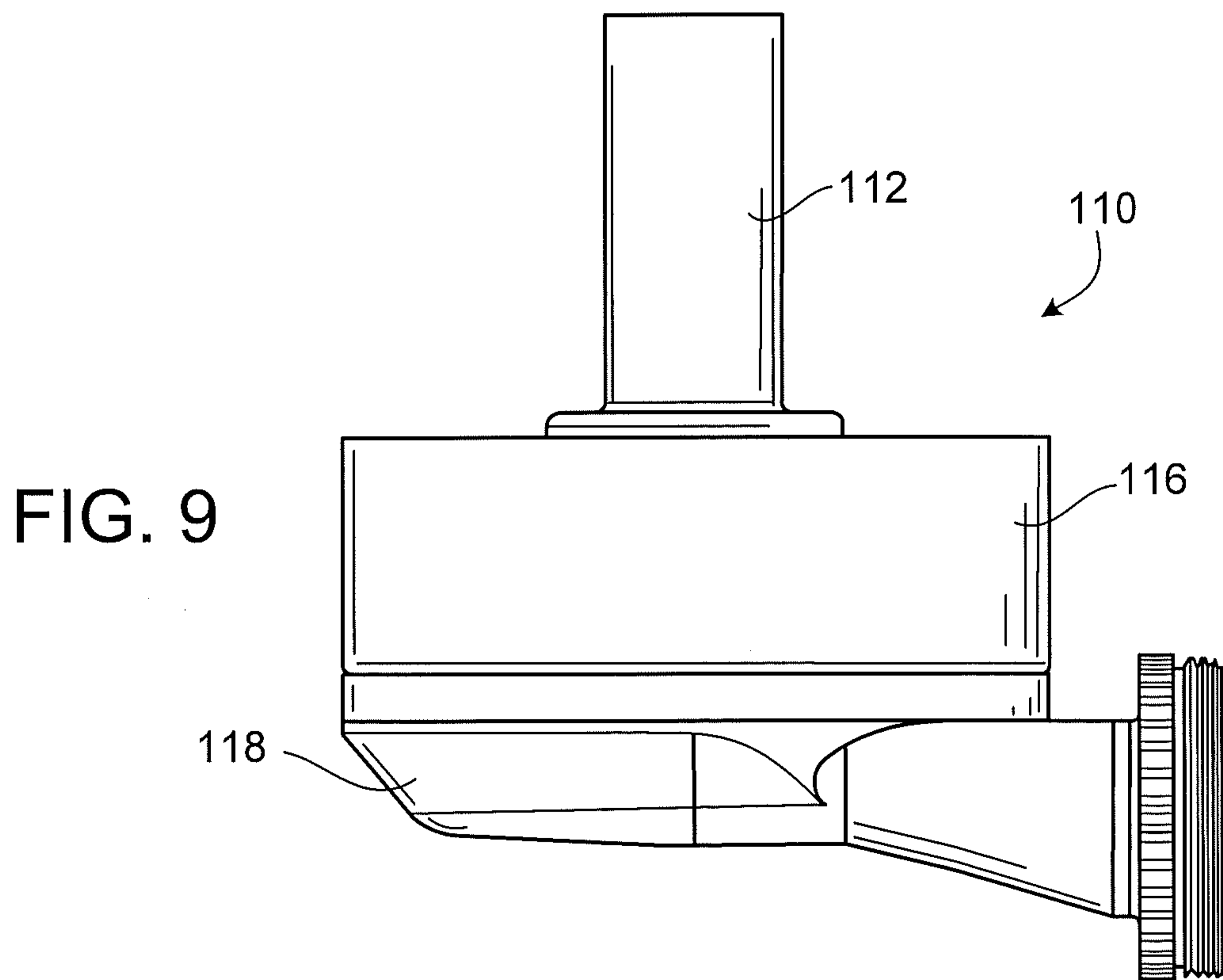
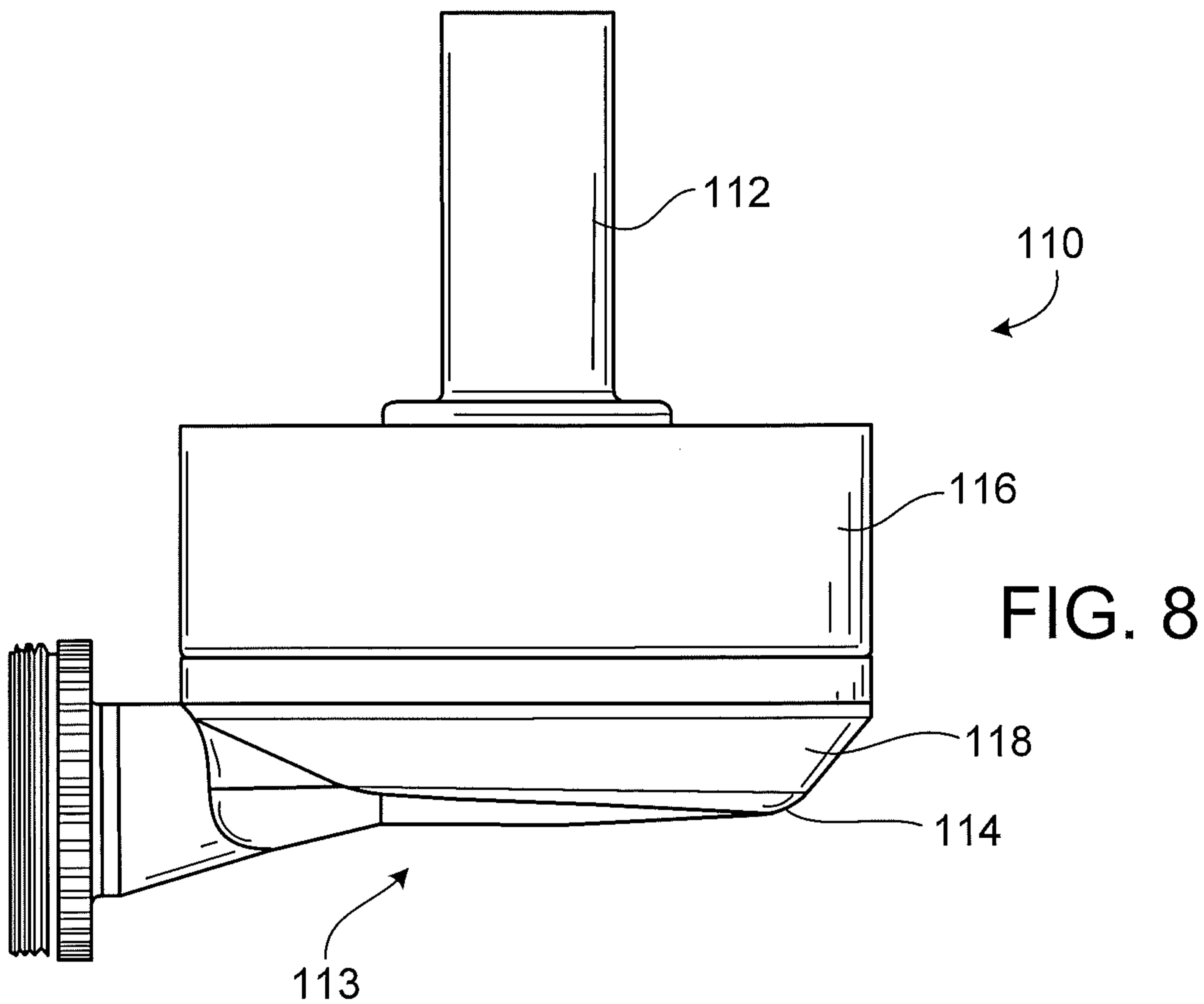
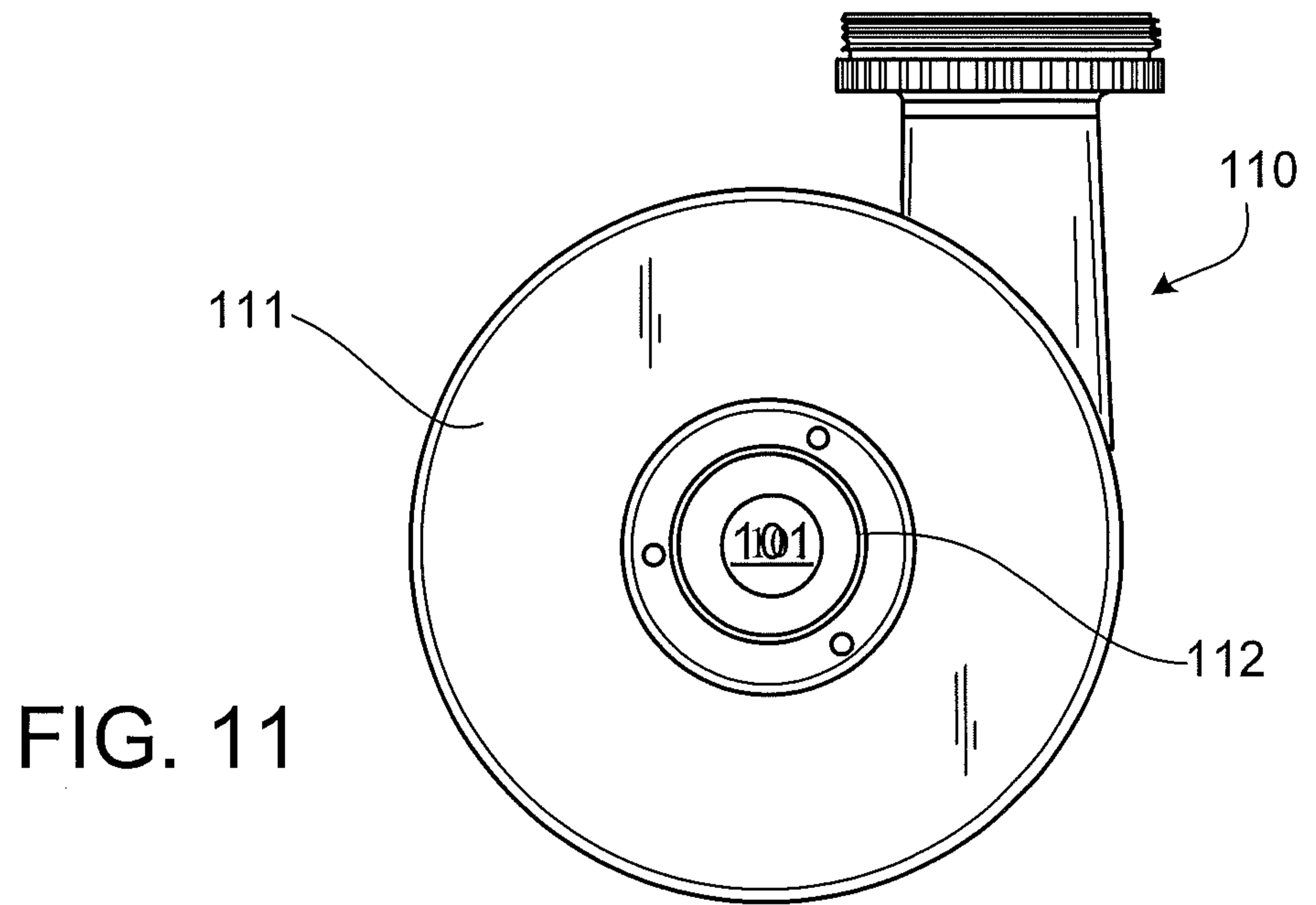
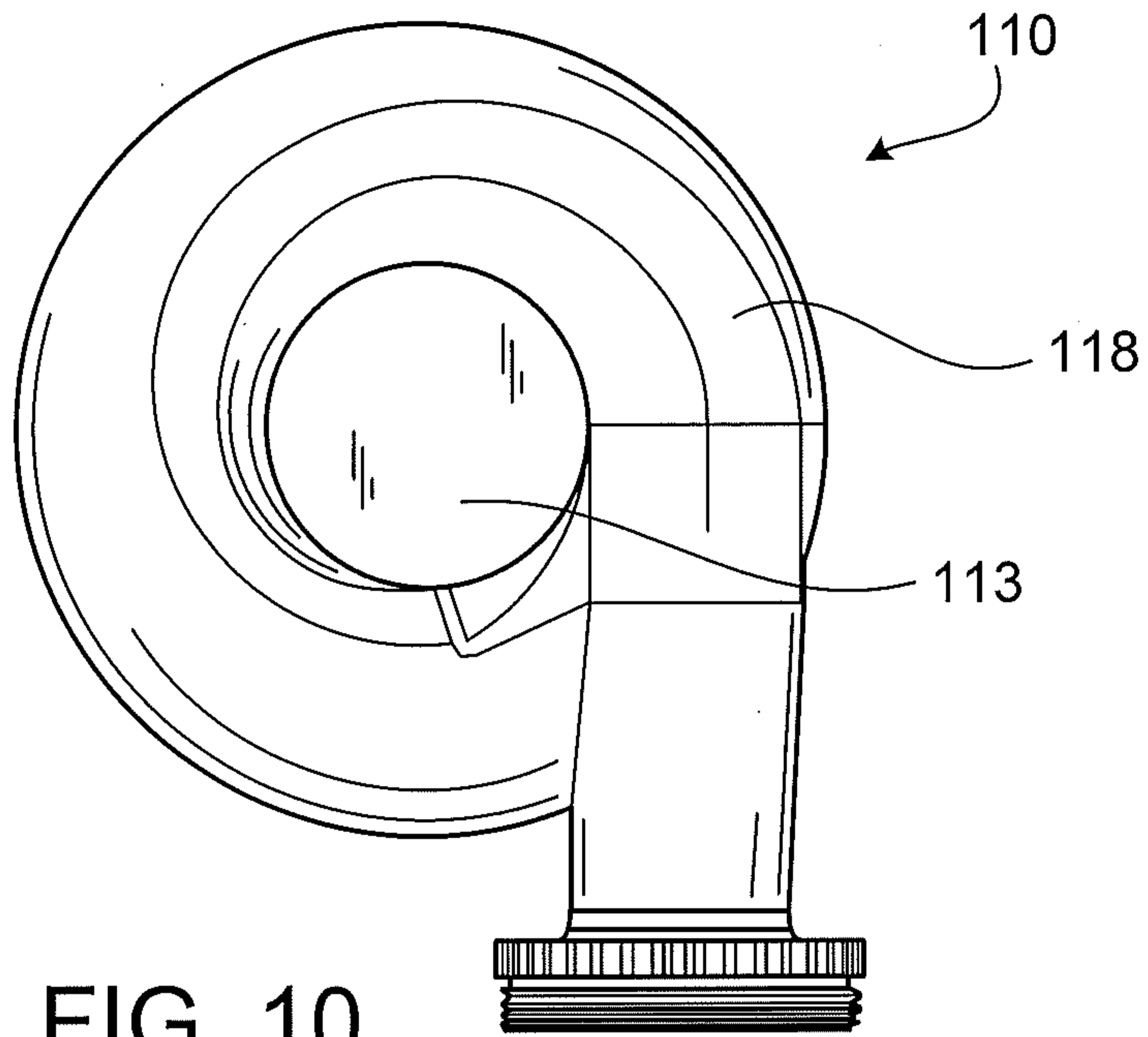

FIG. 7





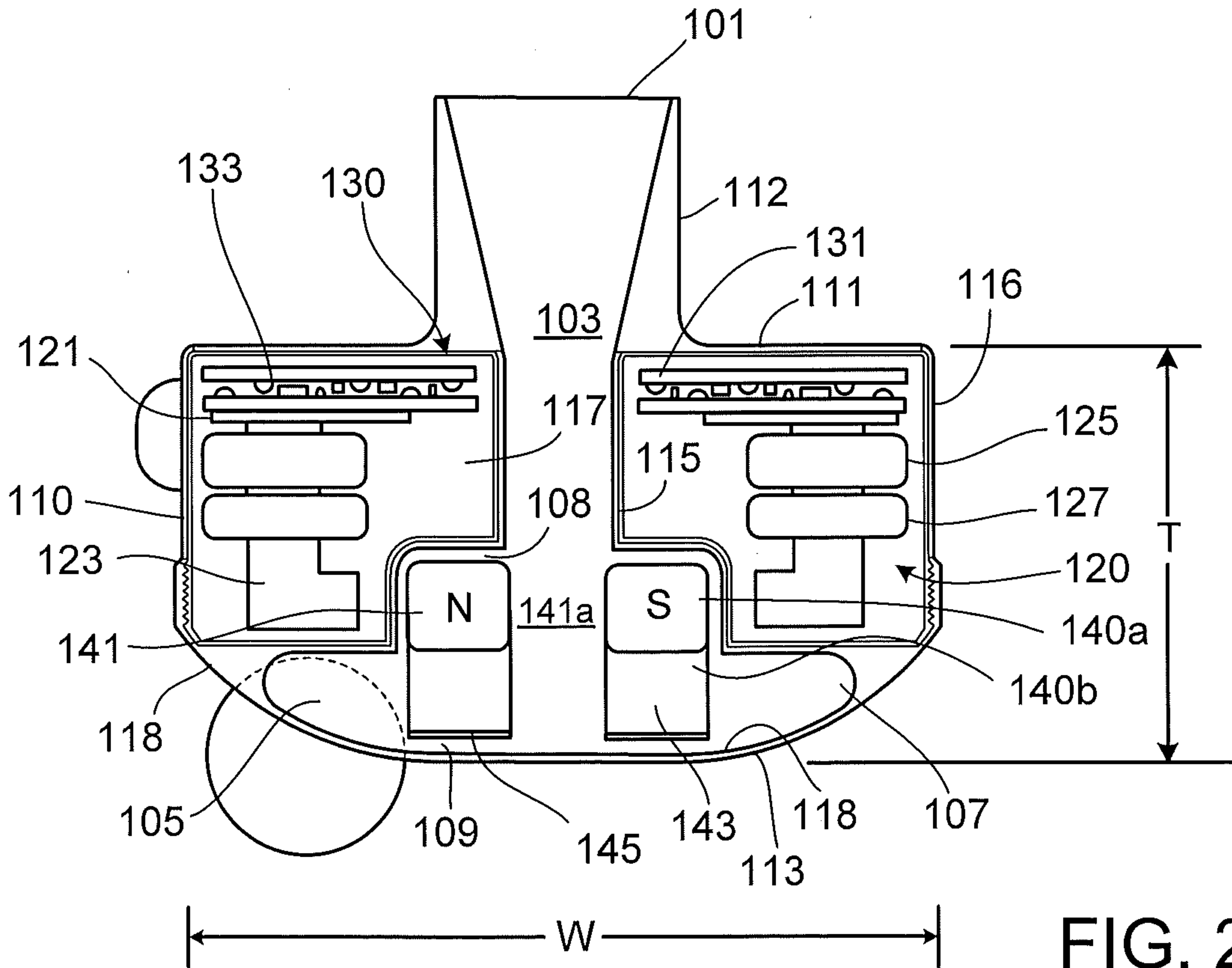

FIG. 2