



(12) **EUROPEAN PATENT APPLICATION**

(43) Date of publication:
27.01.2010 Bulletin 2010/04

(51) Int Cl.:
B25B 23/142 (2006.01)

(21) Application number: **09166084.5**

(22) Date of filing: **22.07.2009**

(84) Designated Contracting States:
**AT BE BG CH CY CZ DE DK EE ES FI FR GB GR
 HR HU IE IS IT LI LT LU LV MC MK MT NL NO PL
 PT RO SE SI SK SM TR**

(72) Inventors:
 • **Celeghin, Lucio**
20099 Sesto San Giovanni (Milano) (IT)
 • **Innamorato, Gianluca**
20067 Paullo (Milano) (IT)

(30) Priority: **23.07.2008 IT MI20081338**

(74) Representative: **De Gregori, Antonella et al**
Ing. Barzano' & Zanardo Milano S.p.A.
Via Borgonuovo 10
20121 Milano (IT)

(71) Applicant: **Beta Utensili S.p.A.**
20050 Sovico (Milan) (IT)

(54) **Method and electronic accessory for angular fastening of a nut or bolt**

(57) Electronic accessory (10) for angular fastening of a nut and/or bolt by means of a wrench comprising a lower portion (12) for coupling with said nut or bolt, an upper portion (11) for coupling with said wrench, said lower and upper portions being aligned along an axis (A), an electronic sensor being further provided for measuring

the rotation of said lower and upper portions around said axis (A), electronic means for setting a preset rotation angle and signalling electronic means of the visual and/or sound and/or touch type, for reaching said preset rotation angle during the rotation of said lower and upper portions (11, 12) around said axis (A).

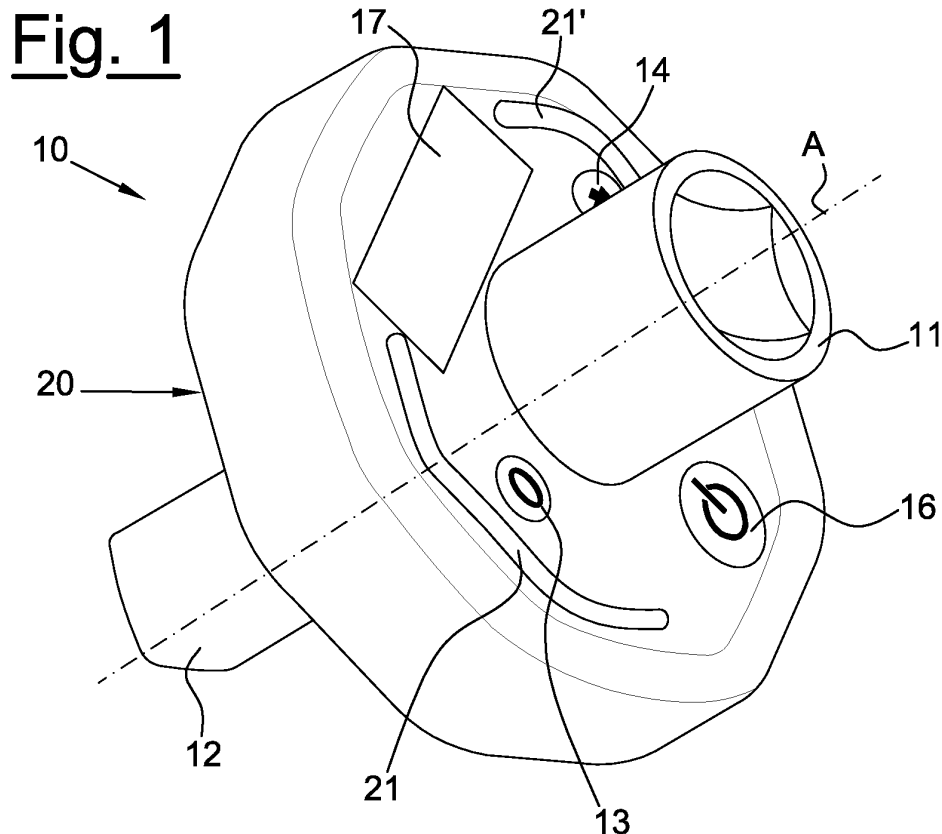

Description

[0001] The present invention refers to a method and an electronic accessory for angular fastening of a nut or bolt independently of the shape.

[0002] As it is already known nowadays, as well as common in the current technique, to carry out a correct fastening of a nut or of a bolt it is not common praxis to only fasten/screw the relative nut or bolt until it reaches a high level of fastening torque, a procedure that could indeed damage the threading and thus not ensure the homogeneity of the torque of the mechanical component, kept in its seat by such a nut or bolt, but it is preferred to fasten/screw the relative nut or bolt until it reaches a predetermined level of fastening torque and subsequently impart a particular rotation on the nut or bolt itself.

[0003] In particular, the value of such a last rotation generally depends on the aforementioned predetermined fastening torque.

[0004] In other words, the procedure currently used for the correct fastening of a nut or a bolt depends on a pair of values which are a force/torque, respectively, expressed in Newtons or Newton metres, and an angle, expressed in degrees, and consists of two distinct steps in which the first step has the purpose of fastening the nut or bolt up to a set fastening force, which is equal to reaching the force/torque required in order to further rotate the nut or bolt, and a second step which is subsequent to the previous one, which has the purpose of imparting a further particular rotation to the nut. In such a way according to the current technique a correct fastening is obtained which does not damage the threading of the relative bolt or nut and ensures homogeneity of the torque on the mechanical component kept in its seat by such a nut or bolt.

[0005] From what has been previously said, it should be gathered that the first step is carried out with "force/torque control" whereas the second with "rotation control".

[0006] Nowadays, in order to carry out the aforementioned correct fastening, as described above, some different devices can be found on the market.

[0007] A first type of widespread devices, used to accomplish the first fastening step i.e., the one carried out with force/torque control, is known by the name "torque wrench" which is simply a controlled fastening manoeuvre wrench which contains a mechanism able to signal when a set force/torque value is reached which can be set at the beginning of the fastening operation.

[0008] Usually, such a signal of the reaching of the set force/torque value can occur mechanically, for example, thanks to a trip mechanism or through a hand which indicates the instantaneous fastening value on a graded scale usually in kilogram metres or Newton metres in the metric system, or electronically by foreseeing load cells suitably arranged and connected to a signalling/reading display. Once such a required torque has been reached, for what has previously been described, the user must

uncouple the torque wrench and use another device to proceed in imparting the further controlled rotation to the nut or bolt.

[0009] The devices known today suitable for accomplishing such a task are in general of the mechanical type and are made up of a graded angular scale goniometer, a shaped base to grip the nut to be fastened, an end to be coupled with the wrench with which the nut is rotated, and a shaft element connected to the goniometer, called "reference".

[0010] In particular, such a last shaft reference element is mobile in rotation to take on a fixed position with respect to the element which is to be stopped with the nut or screw and acts as the origin, or "zero angle", for the further rotation to be carried out.

[0011] As should already be clear from the brief description provided above, the aforementioned last controlled rotation step is very laborious with such devices and requires many manual adjustments, such as the correct fixing of the "reference" shaft and keeping the goniometer in a fixed position during the rotation.

[0012] Of course, due to such manual operations, as well as to the reading of the required rotation which is carried out "visually" by looking at the goniometer scale which necessarily cannot be reduced beyond a limit reading, the correct angular fastening of the nut with such known mechanical devices, is not always ensured and fast nowadays.

[0013] To avoid such problems of correct angular fastening, electronic torque wrenches which incorporate sensors, for example, gyroscopes, are currently available on the market, able to provide a very precise indication of the rotation which is imparted to the nut so as to achieve the two steps of fastening to be carried out with a single tool.

[0014] In other words, such electronic torque wrenches are able to check both the force/torque generated as well as the rotation being imparted to the nut or bolt.

[0015] However, even such devices which achieve a high fastening precision, have some drawbacks, for example, they are difficult and not intuitive to use.

[0016] Indeed such electronic torque wrenches, apart from being very expensive, they also require many initial settings to be input into the wrench itself which, if set in an incorrect way, will necessarily cause the fastening to be different from that required.

[0017] Another drawback, connected to the previous one, is that such wrenches are difficult to use when the fastening must be carried out rapidly, since such wrenches necessarily require a substantial amount of time to be setup before fastening operations. The purpose of the present invention is that of making a device able to overcome the aforementioned drawbacks of the prior art in an extremely simple, cost-effective and particularly functional way.

[0018] Another purpose is that of making a method and an electronic accessory for angular fastening of a nut or bolt which does not damage the threading of the relative

bolt or nut and that ensures homogeneity of the torque of the mechanical component kept in its seat by such a nut or bolt.

[0019] Yet another purpose is that of being able to have a method and an electronic accessory for angular fastening of a nut or a bolt which allows the nut to be rotated in a very precise way.

[0020] Another purpose is that of making an electronic accessory for angular fastening of a nut or a bolt which is easy and fast to use.

[0021] Yet another purpose is that of being able to have an electronic accessory for angular fastening of a nut or bolt which can be used by common torque wrenches known today and by any other manoeuvring tool (wrenches, ratchets, accessories, etc.).

[0022] These purposes according to the present invention are achieved by making a method and an electronic accessory for angular fastening of a nut or bolt as shown respectively in claims 9 and 1. Further characteristics of the invention are highlighted in the subsequent claims.

[0023] The characteristics and the advantages of a method and of an electronic accessory for angular fastening of a nut or bolt according to the present invention shall become clearer from the following description, given as an example and not for limiting purposes, referring to the attached schematic drawings, in which:

figure 1 is a perspective view of an example embodiment of an electronic accessory for angular fastening of a nut and/or bolt according to the present invention;

figure 2 is a top view of the electronic accessory for angular fastening of a nut and/or bolt of figure 1; and
figure 3 shows the operative steps of the electronic accessory for angular fastening a nut and/or bolt according to the present invention.

[0024] With reference to figures 1 and 2, an electronic accessory for angular fastening of a nut or bolt according to the present invention is shown with the numeral 10.

[0025] Such an electronic accessory 10 comprises a lower portion 12, to be coupled with the nut or bolt which is intended to be fastened, and an upper portion 11 to be coupled with the wrench which is intended to be used to rotate the aforementioned nut or bolt.

[0026] In order to ensure a fixed coupling both with the nut or bolt to be fastened as well as with the wrench which is intended to be used for fastening, the aforementioned lower and upper portions 12, 11 can comprise shaped portions so as to match the element to which they are intended to be connected.

[0027] For example, according to the above, such lower and upper portions 12, 11 can foresee suitably shaped cavities, "female" type coupling, or suitably shaped protrusions, "male" type coupling.

[0028] Of course, various sizes of such lower and upper portions 12, 11 are foreseen, and/or, in any case, it is possible to use adaptor elements to be coupled with

the aforementioned lower and upper portions 12, 11 so as to make the accessory 10 of the universal type, suitable for any type of nut or bolt, as well as any wrench in existence today.

[0029] As visible in figure 1, according to the present invention, the aforementioned lower and upper portions 12, 11 are portions with a longitudinal development aligned along an axis A and, if not made in a single piece, they are suitably connected to one another so that acting upon the upper portion 11 in rotation, an equivalent rotation is then imparted on the lower portion 12 and therefore on the nut or bolt intended to be fastened.

[0030] The electronic accessory 10 also comprises an electronic sensor, such as a gyroscope or an accelerometer or other, able to measure the rotation of the upper portion 11 around the aforementioned axis A which is imparted by the user through the wrench. As mentioned, such a rotation also corresponds to the rotation that the lower portion 12 imparts to the relative nut or bolt.

[0031] In such a way the electronic accessory 10 continuously monitors its rotary movement and the relative nut or bolt.

[0032] According to the invention it is foreseen for there to be electronic means for setting, and/or also possibly for storing a "targeted" angle which represents the rotation which is intended to be imparted on the relative nut or bolt during the angular fastening operation which is desired to be performed.

[0033] Moreover, signalling electronic means are foreseen, of the visual and/or sound and/or touch type, such as devices for emitting a luminous/visual signal 21, 21', like the LEDs shown in figures 1 and 2, and/or vibrating devices and/or devices emitting a sound signal.

[0034] In general such signalling electronic means provide a signal during the angular fastening once the aforementioned preset "targeted" rotation angle has been reached.

[0035] In particular according to a preferred embodiment, it is foreseen that such signalling electronic means can start emitting a signal even before the target angle has been reached, i.e., as it is being approached.

[0036] For example, it can be foreseen that with a target angle of 100°, such means begin emitting a signal, for example, of the increasing type, once passed 80° of rotation.

[0037] In such a case, the signal will have a different modularity, generally increasing and different from the signal of the reaching of the target, so that it clearly indicates the nearing and the reaching of the target. The aforementioned signals can happen thanks to the connection present between the electronic sensor for measuring the rotation, the signalling electronic means and a processor which proceeds to continuously compare the measurement detected by the electronic sensor during the rotation of the electronic accessory 10 around the axis A and the preset "targeted" angle.

[0038] According to a preferred embodiment the aforementioned electronic sensor comprises means for meas-

uring the rotation speed imparted on the upper portion around the axis A, which as mentioned, is the same as that imparted on the nut or bolt which is intended to be fastened, as well as means for integrating depending on the time, said measured speed instant by instant, such as the aforementioned microprocessor, so as to obtain a continuous control of the rotation of the electronic accessory 10.

[0039] Therefore, as previously said the electronic accessory 10 provides an indication to the user, of a visual and/or sound and/or touch type, of when during rotation of the nut or bolt the targeted angle is nearing until the preset "targeted" angle has been reached.

[0040] In order to allow variation from time to time, the value of the aforementioned preset "targeted" angle, which can indeed vary from one nut to the next, as well as according to the fastening torque reached in the previous controlled torque fastening step, electronic means are foreseen for resetting the "targeted" angle, in order to allow it to be rapidly set again.

[0041] As visible in figures 1 and 2, the electronic accessory 10 comprises a containment structure 20, generally made from plastic and having minimum bulk arranged radially as a ring between the lower and upper portions 11, 12, in which the measurement sensor, the microprocessor as well as a possibly rechargeable battery, for supplying power to all the electronic devices present in the invention, are housed in the containment structure 20.

[0042] As visible in figure 2 the aforementioned containment structure 20 is provided above with a display 17 which can provide an indication both of the preset "targeted" rotation angle and of the rotation angle measured continuously by the sensor, during the rotation imparted to the upper portion 11 around the axis A.

[0043] According to a preferred embodiment, the aforementioned display, as well as providing the preset "targeted" angle and the continuously measured rotation angle it can also provide an indication of the maximum rotation angle reached during the fastening.

[0044] Such an aspect is important in the case in which the targeted angle has been passed and subsequently an opposite rotation is being carried out.

[0045] For example, after having set the target angle at 100°, in the case in which the rotation has been exceeded to 110°, after having recovered the excessive rotation by turning back, the display will indicate the targeted angle 100°, the current position less than 100° and the maximum angle reached, or rather 110°.

[0046] In general, it is foreseen to use a sensor and a display such as to allow rotation angles greater than 360° to be measured and visualized, without any limit at the predetermined moment.

[0047] Again in the embodiment shown in figure 2, two buttons 14, 15 are foreseen as means for regulating and for resetting the "targeted" angle, one of which is to increase and the other is to decrease the "targeted" angle and a button 13 is foreseen, preferably showing the sym-

bol "0", for resetting the measured angle.

[0048] Of course, in order to ensure energy saving, also an on/off button 16 is foreseen, connected to the battery and to the electronic devices of the electronic accessory 10.

[0049] It should be very easy to understand how the device according to the invention functions.

[0050] Indeed, the method for angular fastening of a nut and/or bolt through the use of an electronic accessory 10 as described above comprises the following simple steps:

- setting the "targeted" rotation angle through the relative setting electronic means such as the regulating buttons 14, 15;
- resetting the tool through a button 13
- rotating, by means of the wrench, the upper portion 11 and then imparting a rotation also on the nut or bolt intended to be fastened;
- stopping the rotation upon a signal emitted by the signalling electronic means of the visual and/or sound and/or touch type, which indeed are activated when the rotation, measured instant by instant by the electronic sensor, nears the preset "targeted" rotation angle, indicating the nearing to the previously preset angle with increasing frequency of the (optical and acoustic) impulses.

[0051] Alternatively, it is also possible to proceed to measure the fastening angle without presetting a "targeted" angle value.

[0052] In such a case, the method comprises the following steps of:

- setting the "zero" value of the "targeted" angle, through the relative electronic setting means, such as the regulation buttons 14, 15
- resetting the tool through the button 13
- rotating the upper portion 11 through the wrench and therefore also imparting a rotation on the nut or bolt which is intended to be fastened, by reading the measured value of the detected angle.

[0053] Of course such a method for angular fastening of a nut and/or bolt through the electronic accessory 10, as well as the turning on of the electronic accessory 10 itself, also comprises a preliminary step of coupling the wrench to the upper portion 11 and the lower portion 12 with the nut or bolt; an intermediate step of reading the progress of the rotation imparted through the wrench on the display; and a final step, as well as switching the electronic accessory 10 itself off, of freeing the wrench from the upper portion 11 and the lower portion 12 from the nut or bolt.

[0054] Once such steps have been completed a new nut or bolt can be fastened by repeating the sequence of steps described above, possibly resetting and setting a new "target" angle.

[0055] It has thus been seen how a method and an electronic accessory for angular fastening of a nut or bolt according to the present invention achieves the previously highlighted purposes.

[0056] Indeed, the electronic accessory for angular fastening of a nut or bolt according to the present invention is simple, intuitive and fast to use, it allows the nut to be rotated in a very precise way and it can be used by common torque wrenches known today, but not only these, and therefore without requiring a high economic investment. The electronic accessory for angular fastening of a nut or bolt for angular fastenings of the present invention thus conceived can undergo numerous modifications and variants, all covered by the same inventive concept; moreover, all the details can be replaced by technically equivalent elements. In practice the materials used, as well as their sizes, can be any according to the technical requirements.

Claims

1. Electronic accessory (10) for angular fastening of a nut and/or bolt by means of a wrench comprising a lower portion (12) for coupling with said nut or bolt, an upper portion (11) for coupling with said wrench, said lower and upper portions being aligned along an axis (A), an electronic sensor being further provided for measuring the rotation of said lower and upper portions around said axis (A), electronic means for setting a preset rotation angle and signalling electronic means of the visual and/or sound and/or touch type, for reaching said preset rotation angle during the rotation of said lower and upper portions (11, 12) around said axis (A).
2. Electronic accessory (10) according to claim 1, **characterised in that** said electronic sensor comprises means for measuring the rotation speed of said lower and upper portions around said axis (A), means for integrating, depending on the time, said measured speed instant by instant.
3. Electronic accessory (10) according to claim 2 **characterised in that** said means for integrating, depending on the time, said measured speed instant by instant are a microprocessor.
4. Electronic accessory (10) according to claim 1, **characterised in that** it comprises means for resetting said preset rotation angle.
5. Electronic accessory (10) according to claim 1 **characterised in that** it comprises a accommodation structure (20) between said lower and upper portions, in said accommodation structure being housed the measuring sensor as well as a battery for supplying all the electronic devices present in said electronic accessory (10).
6. Electronic accessory (10) according to claim 5 **characterised in that** said accommodation structure is provided - on the upper part - with a display (17) for reading said preset rotation angle and said rotation angle measured by said sensor during the rotation of said lower and upper portions (11, 12) around said axis (A).
7. Electronic accessory (10) according to claim 5 **characterised in that** said accommodation structure is provided - on the upper part - with a button (13) for resetting the reading angle, with two buttons (14, 15) for regulating said preset rotation angle, with an on/off button (16) for said electronic accessory (10).
8. Electronic accessory (10) according to claim 5 **characterised in that** said signalling means of the visual and/or sound and/or touch type for reaching said preset rotation angle during the rotation of said lower and upper portions (11, 12) around said axis (A) comprise means for emitting a visual signal (21, 21') and/or vibrating means and/or means for emitting a sound signal.
9. Electronic accessory (10) according to claim 8 **characterised in that** said signalling electronic means also signal the nearing to obtaining said preset rotation angle during the rotation of said lower and upper portions (11, 12) around said axis (A).
10. Electronic accessory (10) according to claim 6 **characterised in that** said display (17) is also used for reading the maximum angle reached during the rotation of said lower and upper portions (11, 12) around said axis (A).
11. Method for angular fastening of a nut and or bolt by means of an electronic accessory (10) according to any one of the preceding claims **characterised in that** it comprises the following steps:
 - setting the "targeted" rotation angle through said setting electronic means;
 - rotating - by means of said wrench - said upper portion (11) and then imparting a rotation also to said nut or bolt intended to be fastened;
 - stopping imparting said rotation upon a signal emitted by said signalling electronic means of the visual and/or sound and/or touch type, said signalling electronic means being activated when said rotation - measured instant by instant by said electronic sensor - reaches said preset "targeted" rotation angle.
12. Method for angular fastening of a nut and or bolt by means of an electronic accessory (10) according to

claim 9 **characterised in that** it comprises the preliminary step of:

- coupling said wrench by said upper portion (11) of said electronic accessory (10) and said lower portion (12) with said nut or said bolt; 5
- the intermediate step of
- controlling the progress of the rotation angle during the rotation of said wrench. 10
- and the final step of
- releasing said wrench from said upper portion (11) of said electronic accessory (10) and said lower portion (12) from said nut or said bolt.

15

20

25

30

35

40

45

50

55

Fig. 1

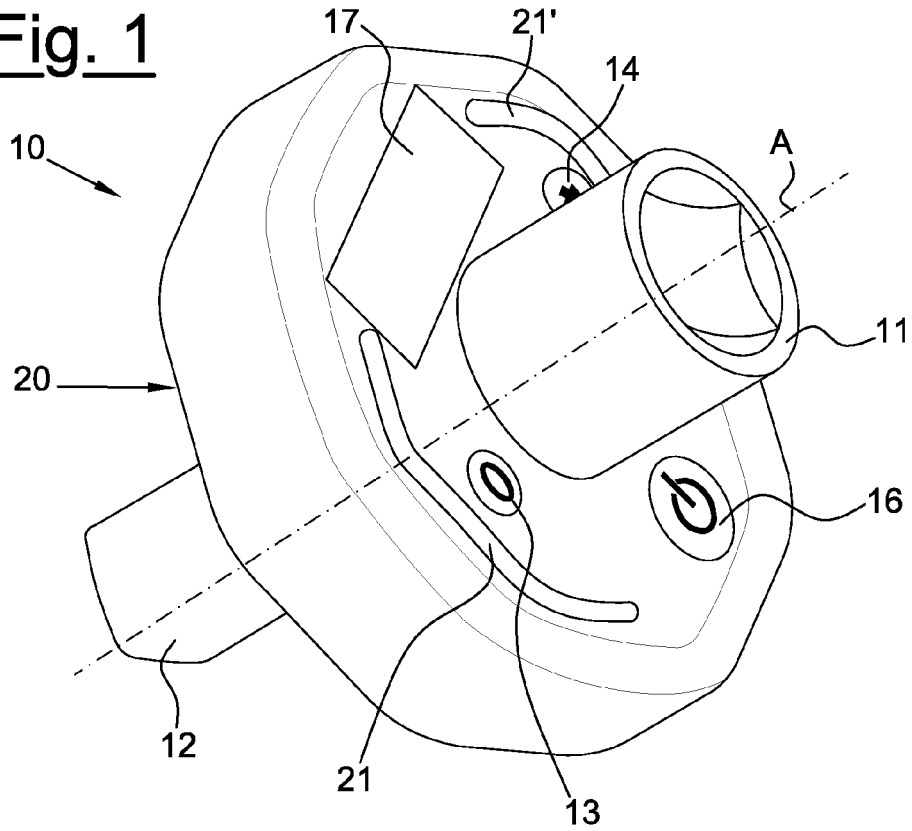

Fig. 2

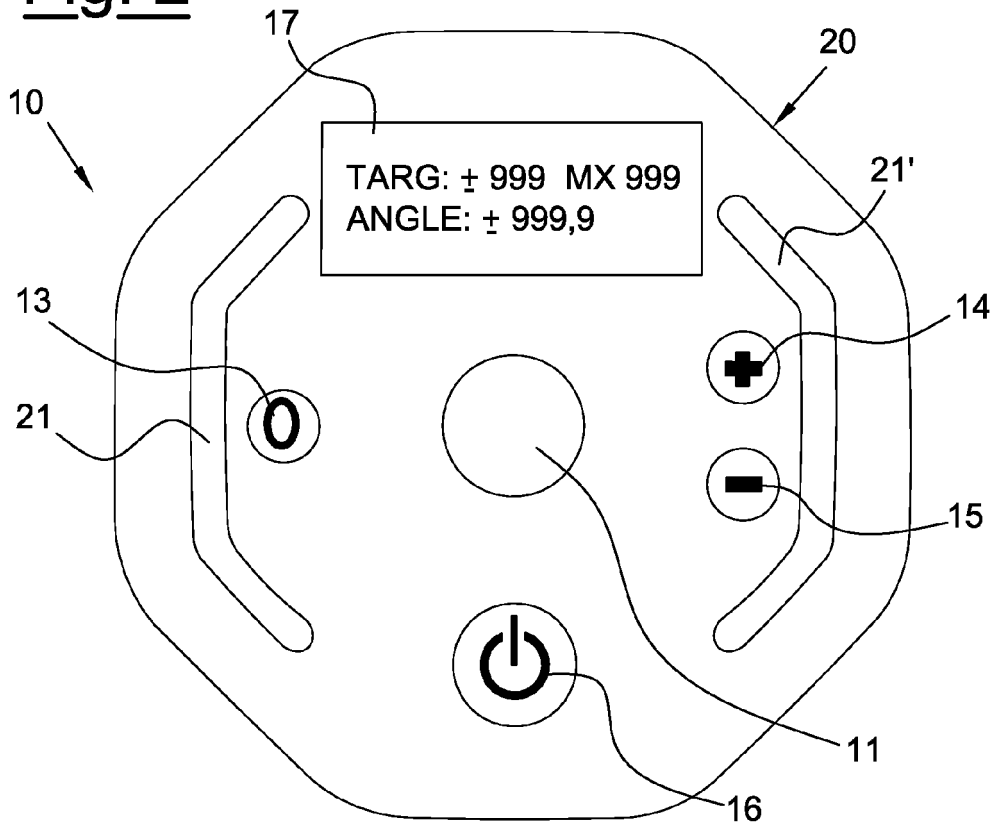
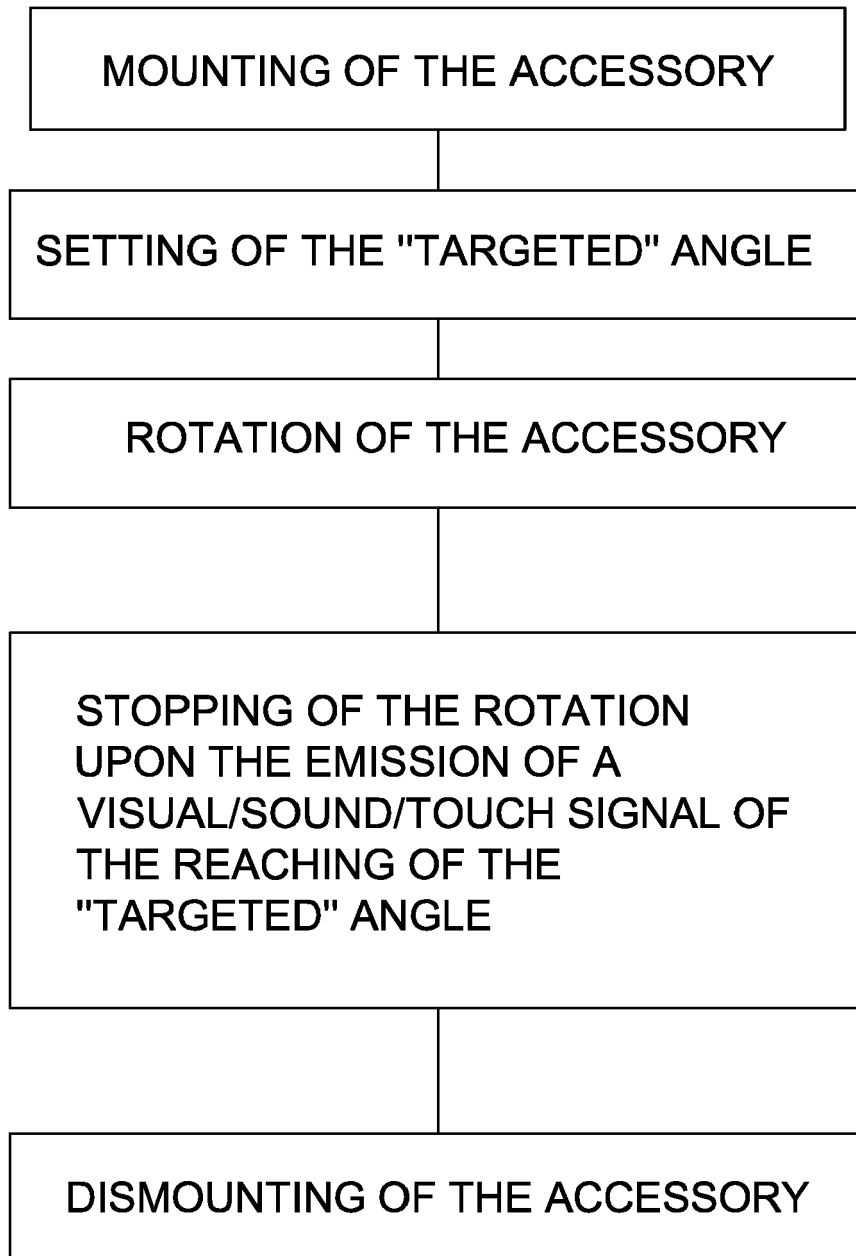

Fig. 3





EUROPEAN SEARCH REPORT

Application Number
EP 09 16 6084

| DOCUMENTS CONSIDERED TO BE RELEVANT | | | |
|--|--|---|---|
| Category | Citation of document with indication, where appropriate, of relevant passages | Relevant to claim | CLASSIFICATION OF THE APPLICATION (IPC) |
| X | US 2003/065456 A1 (MCGEE PHILLIP [US] ET AL) 3 April 2003 (2003-04-03) * paragraph [0006] - paragraph [0013] * * paragraph [0031] - paragraph [0052] * * abstract; figures 1-4 * ----- | 1-12 | INV. B25B23/142 |
| X | DE 195 81 468 T1 (SNAP ON TOOLS CORP [US]) 2 January 1997 (1997-01-02) * page 8, line 12 - page 11, line 26; figure 5 * ----- | 1-4, 11-12 | |
| | | | TECHNICAL FIELDS SEARCHED (IPC) |
| | | | B25B |
| The present search report has been drawn up for all claims | | | |
| Place of search Munich | | Date of completion of the search 28 August 2009 | Examiner Kühn, Thomas |
| CATEGORY OF CITED DOCUMENTS X : particularly relevant if taken alone Y : particularly relevant if combined with another document of the same category A : technological background O : non-written disclosure P : intermediate document | | T : theory or principle underlying the invention E : earlier patent document, but published on, or after the filing date D : document cited in the application L : document cited for other reasons & : member of the same patent family, corresponding document | |

5
EPO FORM 1503 03.02 (P/4C01)

**ANNEX TO THE EUROPEAN SEARCH REPORT
ON EUROPEAN PATENT APPLICATION NO.**

EP 09 16 6084

This annex lists the patent family members relating to the patent documents cited in the above-mentioned European search report. The members are as contained in the European Patent Office EDP file on
The European Patent Office is in no way liable for these particulars which are merely given for the purpose of information.

28-08-2009

| Patent document cited in search report | Publication date | Patent family member(s) | Publication date |
|--|------------------|-------------------------|------------------|
| US 2003065456 A1 | 03-04-2003 | US 2006009924 A1 | 12-01-2006 |
| DE 19581468 T1 | | NONE | |

EPO FORM P0459

For more details about this annex : see Official Journal of the European Patent Office, No. 12/82