

(19)



(11)

EP 1 573 165 B1

(12)

EUROPEAN PATENT SPECIFICATION

(45) Date of publication and mention of the grant of the patent:
28.01.2015 Bulletin 2015/05

(51) Int Cl.:
E06B 9/42 (2006.01) E06B 9/56 (2006.01)

(21) Application number: **03773583.4**

(86) International application number:
PCT/DK2003/000796

(22) Date of filing: **20.11.2003**

(87) International publication number:
WO 2004/053282 (24.06.2004 Gazette 2004/26)

(54) SCREENING DEVICE AND METHOD FOR MOUNTING SUCH DEVICE

JALOUSIEVORRICHTUNG UND METHODE ZUR BEFESTIGUNG EINER SOLCHEN VORRICHTUNG

DISPOSITIF ECRAN ET SON PROCEDE DE MONTAGE

(84) Designated Contracting States:
AT BE BG CH CY CZ DE DK EE ES FI FR GB GR HU IE IT LI LU MC NL PT RO SE SI SK TR
Designated Extension States:
AL LT LV MK

(72) Inventor: **JENSEN, Jimmy, Skjold**
DK-5591 GELSTED (DK)

(30) Priority: **09.12.2002 DK 200201882**

(74) Representative: **Carlsson, Eva et al**
Awapatent A/S
Rigensgade 11
1316 Copenhagen K (DK)

(43) Date of publication of application:
14.09.2005 Bulletin 2005/37

(56) References cited:
EP-A- 0 549 209 WO-A-00/05478
WO-A-98/32944 US-A- 4 574 864
US-A- 5 535 806 US-A- 6 112 800
US-B1- 6 338 378

(73) Proprietor: **VKR Holding A/S**
2970 Hørsholm (DK)

EP 1 573 165 B1

Note: Within nine months of the publication of the mention of the grant of the European patent in the European Patent Bulletin, any person may give notice to the European Patent Office of opposition to that patent, in accordance with the Implementing Regulations. Notice of opposition shall not be deemed to have been filed until the opposition fee has been paid. (Art. 99(1) European Patent Convention).

Description

[0001] The present invention relates to a screening device according to the introductory part of claim 1.

[0002] An arrangement for mounting and parallel guidance is known from Applicant's EP 0 960 253, which discloses a screening device, including blinds for darkening purposes, roller blinds, pleated blinds and Venetian blinds, for a window. The arrangement comprises parallel guidance by means of two cords, which are each extending from one of the upper corners of the window through a hollow bottom bar to the lower corner of the opposite side of the window. The cords are in the upper corners fixed by means of a tension spring to attain an adequate tension of the cords for parallel guidance, such that when in use they have such a tension that the screening member of the screening device easily and without problems can be moved across the window.

[0003] In order to obtain an unproblematic guidance of the screening device in the parallel guidance system, the tension of the cords has to be within a certain interval, which i.a. depends on the length of the window opening. If the cords are tightened too loosely, the bottom bar tends to move askew or get stuck, just as the friction may be too low, the result being that a screening device, like for instance a conventional roller blind, on account of the spring load of the screening member cannot be retained, when the screening member has been moved to the position, in which the opening is exposed. If the cords are tightened too much, the friction becomes too high, the result being that movement of the screening member across the opening is made difficult, just as there is a risk that the cord may be ruined.

[0004] The adjustment of the cords to a tension suitable for parallel guidance is, however, problematic, when used according to prior art, as the suitable tension interval i.a. varies in accordance with the length of the window. As the tension springs are hidden, it is furthermore difficult to tighten the cords so that they have the same tension, the result being that there is a risk that the bottom bar will be guided obliquely with respect to the cords.

[0005] It is the object of the present invention to provide a screening device of the above-mentioned type, in which correct mounting of the device is easy and simple, and in which the movement of the screening member in use can be carried out readily and without problems.

[0006] To meet this object the screening device is characterized by the features of the characterizing part of claim 1.

[0007] By marking the degree, to which the cords are to be tightened in different mounting situations, the mounting of the screening device is made considerably easier. Moreover, the suitable tensioning of the cords has the effect that the screening member, when in use, can be moved easily to cover the opening, as the friction during the movement is of a suitable size, and askew guidance of the screening member is avoided in a simple manner.

In an advantageous embodiment of the invention each tension spring is associated with one first marking and two or more second markings are provided at positions predetermined relative to the mounting member. The two or more second markings may for instance be arranged on the mounting member, and each corresponds to a length or an interval of lengths of the longitudinal sides of the screening member, when the screening member is in the position, in which it extends substantially over the entire opening. During the mounting of the screening device, the tension of the cords is thus adjusted relative to the length of the longitudinal sides in the above-mentioned position, which is advantageous in that a suitable tension can be attained with the same screening device for several different lengths of the longitudinal sides, for instance several different heights of a window opening.

[0008] According to another embodiment the mounting members are positioned at the end adapted to be fastened on the element surrounding the aperture, and the mounting members and said end are positioned at the top relative to the aperture. Hereby the mounting of the screening device is facilitated, as the cords are to be pulled downwards during the adjustment of the tension. Moreover, the screening member is in this embodiment guided from above and downwards like is the case with a conventional roller blind. Alternatively, it is also possible to place the end adapted to be secured to the element surrounding the opening at the top relative to the opening, whereas the mounting members are positioned at the bottom or vice versa, just as one spring may be positioned at one end of the window opening and the other spring at the other end of the window opening.

[0009] In yet another embodiment the matching first and second markings are visible during the mounting process and hidden, when the screening device is in use, for instance by means of a lid, or the marking can be removed from the screening device after the tightening of the cords. In this manner the cords can be tightened in accordance with markings, which will not be visible after the mounting.

[0010] In a further embodiment the second marking at the position predetermined relative to the mounting member is a stop stopping the tightening of the tension spring during the mounting of the screening device, when the cord has a suitable tension. During the mounting the cords thus simply have to be pulled, until they cannot be pulled any further, to adjust them to their suitable tension, which makes the mounting easier and less complicated.

[0011] In a preferred embodiment of the invention the free end of the screening member can, when in use, be placed in a position between the first and the second positions, in which the screening member is rolled up, collapsed or folded, and the second position, in which the screening member extends substantially across the entire opening. If the screening device has the character of a sunshade or the like, with which it is often only desirable to be able to cover a part of the opening, the screening member may thus fulfil this function.

[0012] According to another embodiment the longitudinal sides of the screening member are guided in rails mounted at the sides of the aperture. For screening devices like for instance insect webs or blinds for darkening purposes this embodiment will protect effectively against insects and light.

[0013] In an advantageous embodiment during transport and installation of the screening device at least one fixing means is provided for securing the free end of the screening member to its secured end. This embodiment is advantageous, as the individual parts of the screening device during transport will tend less to disengage one another. In the prior art the free end will be pulled askew, as it is movable during the adjustment of the tightening of the cords, when one of the cords is tightened. When the free end after tightening of one of the cords is aligned again, the tension of the cord will change, and it may be necessary to adjust by tightening it several times. The same problem arises at the tightening of the other cord. The fixing of the free end during the mounting has the effect that the free end is maintained in its position, which is parallel to the fixed end, for which reason the tension of the cords will be correct after the first adjustment.

[0014] In another embodiment the secured end is mounted on the element surrounding the aperture, the cords are tightened by pulling until each of the first markings on each tension spring substantially matches their matching second marking at the position predetermined relative to the mounting member, and the cords are secured in this position. By this method a quick, easy and correct mounting of the screening device is obtained.

[0015] In a further embodiment the fixing means for securing the free end of the screening member to its secured end is detached after mounting. At this point, the fixing means has no function, and detachment thereof will improve the handling, functioning and appearance of the screening device.

[0016] In yet another embodiment the cords are during transport and/or during part of the mounting secured to the fixing means. In this way the cords are prevented from getting entangled in themselves and/or one another.

[0017] Furthermore, the cords can be shortened after the tightening and the securing thereof. Thus, the cords are made easier to control, just as they do not protrude after the mounting of the screening device.

[0018] The invention will be explained in detail in the following by means of examples of embodiments with reference to the schematic drawing, in which

Fig. 1 is a perspective view of an embodiment of a screening device according to the invention prior to the mounting of the device,

Fig. 2 is a plan view of the screening device according to Fig. 1 during the mounting at an aperture in a building,

Fig. 2a is a sectional view of Fig. 2 of a fixing fitting, Fig. 2b is a sectional view of Fig. 2 of the guidance of the cords through a side rail,

Fig. 3 is a plan view of the screening device during the mounting at the building aperture,

Fig. 3a is a sectional view of Fig. 3 of a spring housing of the screening device, and

Fig. 4 is a plan view of the screening device mounted on the window in which the screening member has been brought to screen the window.

[0019] Fig. 1 is a view of an embodiment of a screening device 1 according to the invention prior to the mounting of the device, in which the screening member is an insect roller web 2 (Fig. 4). The device 1 comprises a housing 4 containing the insect roller web 2, when rolled up, a bottom bar 5 for guiding the web 2 over an aperture in a building 6 and two mounting members in the form of spring housings 10. One end of a tension spring 9 is fixed in each spring housing 10, the other end of the tension spring being fixed to a cord 7, 8 for parallel guidance of the bottom bar 5 and the insect roller web 2. For each spring housing a lid 13 is provided to hide the tension spring 9, the portion of the cord 7, 8, which is present in the spring housing 10, and second markings in the form of markings 11 (Fig. 3a) in the spring housing 10. Fixing means in the form of two fixing fittings 14 are provided on the bottom bar 5, the cords 7, 8 being wound around said two fixing fittings during transport and during part of the mounting.

[0020] Fig. 2 shows the screening device 1 during mounting on a wall or a frame at the building aperture 6. The housing 4 is fixed on the wall above the building aperture 6, following which the cords 7, 8 are unwound from the fixing fittings 14, see Fig. 2a, guided down along side rails 15 and then in the direction of the arrows through holes in the side rails 15 at the bottom end thereof, see Fig. 2b, following which the cords 7, 8 are tightened to a suitable degree, which will be explained in detail in the following, and fixed by means of screws (not shown) on the exterior side of the side rails 15, and the cords 7, 8 are shortened.

[0021] Fig. 3 likewise shows the screening device during mounting. In the sectional view shown in Fig. 3a it is illustrated by an arrow, how the cord 7, 8 is tightened by means of a first marking in the form of marking 12 on the tension spring 9 in the spring housing 10. Each of the two markings 11 corresponds to an interval of the height of the window opening, the marking designated by I for instance stating the tension of the cord for height of the window opening from 0 to 1800 mm, and the marking designated II for instance stating the tension for heights from 1800 to 2400 mm. In this manner the embodiment shown of the screening device according to the invention can be mounted in an easy manner in respect of all heights of the window opening from 0 to 2400 mm, and will at the same time be easy to move across the building aperture when in use, however, with the prerequisite that the side rails 15 are shortened to correspond to the height of the opening.

[0022] Fig. 4 shows the screening device 1 when in

use, the device being mounted at the building aperture 6, and the screening member 2 being by means of the bottom bar 5 brought to cover the building aperture 6. The fixing fittings 14 have been detached in the situation of use as they no longer have a function.

[0023] The screening device may be designed in other ways than the above-mentioned ones. The screening member may for instance be a conventional roller blind, a pleated blind or Venetian blinds. The embodiment shown is adapted for mounting on a window frame or a wall. The screening device may, however, also be placed directly on the window sash.

[0024] Moreover, the screening device may be mounted without the side rails, just as the free end of the screening member may be designed in another way than as a hollow bottom bar, for instance as a solid bottom bar or solely as a stiffener. In the latter embodiments the cords are not taken through a member at the free end of the screening member, but are still guided in parallel along the free end, for instance through a groove or an annular member at each side end of the free end of the screening member.

[0025] Additionally, the secured end of the screening member, which in the embodiment shown is constituted by the housing, may be placed at the sides of or under the building aperture such that the free end of the screening member is moved from the side or upwards under the screening of the building aperture.

[0026] The screening device according to the invention is not limited to screening of rectangular or even quadrangular building apertures; it may for instance be used for screening circular, oval or triangular windows.

[0027] The number of markings at the predetermined position predetermined relative to the mounting member may moreover be extended to apply to several and larger or smaller intervals of the length of the longitudinal sides of the screening member.

Claims

1. A screening device (1) for screening an aperture, in particular to be mounted on a building element surrounding an aperture (6) in a building, such as a window opening, a door opening or the like, comprising a screening member (2), which can be rolled up, collapsed or folded, said screening member having two longitudinal sides (3), one end (4) adapted to be secured on an element surrounding the aperture (6) and another end (5) adapted to be moved between a first position, in which the screening member (2) is rolled up, collapsed or folded, and a second position, in which the screening member (2) extends over substantially the entire aperture (6), the screening device (1) further comprising two cords (7, 8) for parallel guidance of the free end (5) of the screening member (2), the cords (7, 8) being taken along the free end (5) of the screening member (2) between the two longitudinal sides (3) of the screening member (2), and the cords (7, 8) being connected at one end by tension springs (9) with a mounting member (10) adapted to be fixed on the element surrounding the aperture (6) for tightening the cord at the mounting of the screening device (1), **characterized** in that a first marking (12) is associated with each tension spring (9), and a second marking (11) is associated with the screening device at a position predetermined relative to the mounting member (10), such that the cord (7, 8) in the mounted position of the screening device (1) has a tension suitable for the parallel guidance, when each of the first markings (12) associated with the tension springs (9) substantially matches the second marking (11) at the position predetermined relative to the mounting member (10).
2. A screening device (1) according to claim 1 or 2, **characterized in that** each tension spring (9) is associated with one first marking (12), and two or more second markings (11) are provided at positions predetermined relative to the mounting member (10).
3. A screening device (1) according to one of the claims 1 - 2, **characterized in that** the mounting members (10) are positioned at the end (4) adapted to be fastened on the element surrounding the aperture (6) and the mounting members (10) and said end (4) are positioned at the top relative to the aperture (6).
4. A screening device (1) according to one of the claims 1 - 3, **characterized in that** the matching second and first markings (11, 12) are visible during the installation process and hidden, when the screening device is in use, for instance by means of a lid (13).
5. A screening device (1) according to one of the claims 1 - 4, **characterized in that** the second marking (11) at the position predetermined relative to the mounting member (10) is a stop stopping the tightening of the tension spring (9) during the mounting of the screening device (1), when the cord (7, 8) has a tension suitable for the parallel guidance.
6. A screening device (1) according to one of the claims 1 - 5, **characterized in that** when in use the free end (5) of the screening member (2) can be placed in a position between the first and the second positions, this being achieved by a suitable friction between the cords (7, 8) and the free end (5), said suitable friction being achieved when the cords (7, 8) have a tension suitable for the parallel guidance.
7. A screening device (1) according to one of the claims 1 - 6, **characterized in that** the longitudinal sides (3) of the screening member (2) are guided in rails (15) mounted at the sides of the aperture (6).

8. A screening device (1) according to one of the claims 1 - 7, **characterized in that** during transport and installation of the screening device (1) at least one fixing means (14) is provided for securing the free end (5) of the screening member (2) to its secured end (4). 5
9. A method for mounting a screening device (1) according to one of the claims 1 - 8, **characterized in that** the secured end (4) is mounted on the element surrounding the aperture (6), the cords (7, 8) are tightened by pulling until each of the first markings (12) on each tension spring (9) substantially matches their matching second marking (1) at the position predetermined relative to the mounting member (10), and the cords (7, 8) are secured in this position. 10
10. A method according to claim 9, **characterized in that** the fixing means (14) for securing the free end (5) of the screening member (2) to its secured end (4) is detached after installation. 20
11. A method according to claim 9 or 10, **characterized in that** the cords (7, 8) during transport and/or during part of the mounting are secured to the fixing means (14). 25
12. A method according to one of the claims 9 - 11, **characterized in that** the cords (7, 8) are shortened after the tightening and securing thereof. 30

Patentansprüche

1. Abschirmeinrichtung (1) zum Abschirmen einer Öffnung, insbesondere zum Anbringen an einem Gebäudeelement, das eine Öffnung (6) in einem Gebäude umgibt, wie beispielsweise eine Fensteröffnung, eine Türöffnung oder Ähnliches, mit einem Abschirmelement (2), das aufgerollt, zusammengelegt oder gefaltet werden kann, wobei das Abschirmelement zwei Längsseiten (3), ein Ende (4), das angepasst ist, um an einem Element, das die Öffnung (6) umgibt, befestigt zu werden, und ein anderes Ende (5) aufweist, das angepasst ist, um zwischen einer ersten Stellung, in der das Abschirmelement (2) aufgerollt, zusammengelegt oder gefaltet ist, und einer zweiten Stellung bewegt zu werden, in der sich das Abschirmelement (2) im Wesentlichen über die gesamte Öffnung (6) erstreckt, wobei die Abschirmeinrichtung (1) ferner zwei Schnüre (7, 8) für eine parallele Führung des freien Endes (5) des Abschirmelements (2) aufweist, wobei die Schnüre (7, 8) entlang des freien Endes (5) des Abschirmelements (2) zwischen den zwei Längsseiten (3) des Abschirmelements (2) gezogen sind und wobei die Schnüre (7, 8) an einem Ende durch Spannfedern (9) mit einem Montageelement (10) verbunden sind, das ange-

passt ist, an dem Element befestigt zu werden, das die Öffnung (6) umgibt, um die Schnur bei der Montage der Abschirmeinrichtung (1) zu spannen, **dadurch gekennzeichnet, dass** eine erste Markierung (12) jeder Spannfeder (9) zugeordnet ist und dass eine zweite Markierung (11) der Abschirmeinrichtung an einer Position zugeordnet ist, die relativ zu dem Befestigungselement (10) so vorgegeben ist, dass die Schnur (7, 8) in der montierten Stellung der Abschirmeinrichtung (1) eine Spannung hat, die für die parallele Führung geeignet ist, wenn jede der ersten Markierungen (12), die den Spannfedern (9) zugeordnet sind, im Wesentlichen die zweite Markierung (11) an der relativ zu dem Befestigungselement (10) vorbestimmten Position trifft.

2. Abschirmeinrichtung (1) nach Anspruch 1 oder 2, **dadurch gekennzeichnet, dass** jeder Spannfeder (9) eine erste Markierung (12) zugeordnet ist und dass zwei oder mehrere zweite Markierungen (11) an Positionen vorgesehen sind, die relativ zu dem Befestigungselement (10) vorgegeben sind.
3. Abschirmeinrichtung (1) nach einem der Ansprüche 1 bis 2, **dadurch gekennzeichnet, dass** die Befestigungselemente (10) an dem Ende (4) angeordnet sind, das angepasst ist, an dem Element befestigt zu werden, das die Öffnung (6) umgibt, und dass die Befestigungselemente (10) und das Ende (4) an der Oberseite relativ zu der Öffnung (6) angeordnet sind.
4. Abschirmeinrichtung (1), nach einem der Ansprüche 1 bis 3, **dadurch gekennzeichnet, dass** die sich einander treffenden ersten und zweiten Markierungen (11, 12) während des Installationsprozesses sichtbar und verdeckt sind, wenn die Abschirmeinrichtung in Benutzung ist, zum Beispiel mittels eines Deckels (13).
5. Abschirmeinrichtung (1), nach einem der Ansprüche 1 bis 4, **dadurch gekennzeichnet, dass** die zweite Markierung (11) an einer relativ zu dem Befestigungselement (10) vorgegebenen Position ein Anschlag ist, der das Festziehen der Spannfeder (9) während der Montage der Abschirmvorrichtung (1) stoppt, wenn die Schnur (7, 8) eine Spannung hat, die für die parallele Führung geeignet ist.
6. Abschirmeinrichtung (1), nach einem der Ansprüche 1 bis 5, **dadurch gekennzeichnet, dass** in der Benutzung das freie Ende (5) des Abschirmelements (2) in einer Stellung zwischen der ersten und der zweiten Stellung angeordnet werden kann, wobei dies durch eine geeignete Reibung zwischen den Schnüren (7, 8) und dem freien Ende (5) erreicht wird, wobei die geeignete Reibung erreicht wird, wenn die Schnüre (7, 8) eine Spannung haben, die für die parallele Führung geeignet ist.

7. Abschirmeinrichtung (1), nach einem der Ansprüche 1 bis 6, **dadurch gekennzeichnet, dass** die Längsseiten (3) des Abschirmelements (2) in Schienen (15) geführt sind, die an den Seiten der Öffnung (6) angebracht sind.
8. Abschirmeinrichtung (1), nach einem der Ansprüche 1 bis 7, **dadurch gekennzeichnet, dass** während des Transports und der Installation der Abschirmeinrichtung (1) wenigstens ein Fixierelement (14) zum Sichern des freien Endes (5) des Abschirmelements (2) an dessen befestigtem Ende (4) vorgesehen ist.
9. Verfahren zum Anbringen einer Abschirmeinrichtung (1), nach einem der Ansprüche 1 bis 8, **dadurch gekennzeichnet, dass** das befestigte Ende (4) an dem Element, das die Öffnung (6) umgibt, angebracht wird, die Schnüre (7, 8) durch Ziehen, bis jede der ersten Markierungen (12) an jeder Spannfeder (9) im wesentlichen deren treffende zweite Markierung (1) an der relativ zu dem Befestigungselement (10) vorgegebenen Position trifft, und die Schnüre (7, 8) in dieser Position befestigt werden.
10. Verfahren nach Anspruch 9, **dadurch gekennzeichnet, dass** das Fixierelement (14) zum Sichern des freien Endes (5) des Abschirmelements (2) an dessen befestigtem Ende (4) nach der Installation gelöst wird.
11. Verfahren nach Anspruch 9 oder 10, **dadurch gekennzeichnet, dass** die Schnüre (7, 8) während des Transports und/oder während eines Teils der Montage an dem Fixierelement (14) gesichert sind.
12. Verfahren nach Anspruch 9 bis 11, **dadurch gekennzeichnet, dass** die Schnüre (7, 8) nach dem Spannen und Sichern davon gekürzt werden.

Revendications

1. Dispositif écran (1) destiné à occulter une ouverture, en particulier à être monté sur un élément de construction entourant une ouverture (6) dans un immeuble, telle qu'une ouverture de fenêtre, une ouverture de porte ou analogue, comportant un élément écran (2), lequel peut être enroulé, escamoté ou replié, ledit élément écran comportant deux côtés longitudinaux (3), une extrémité (4) conçue pour être fixée sur un élément entourant l'ouverture (6) et une autre extrémité (5) conçue pour être déplacée entre une première position, dans laquelle l'élément écran (2) est enroulé, escamoté ou replié, et une seconde position dans laquelle l'élément écran (2) s'étend essentiellement sur la totalité de l'ouverture (6), le dispositif écran (1) comportant, de plus, deux cordons

(7, 8) destinés à un guidage parallèle de l'extrémité libre (5) de l'élément écran (2), les cordons (7, 8) étant pris le long de l'extrémité libre (5) de l'élément écran (2) entre les deux côtés longitudinaux (3) de l'élément écran (2), et les cordons (7, 8) étant raccordés au niveau d'une extrémité par des ressorts de tension (9) avec un élément de montage (10) conçu pour être fixé sur l'élément entourant l'ouverture (6) en vue de tendre le cordon au niveau du montage du dispositif écran (1), **caractérisé en ce qu'un** premier repère (12) est associé à chaque ressort de tension (9), et un second repère (11) est associé au dispositif écran à une position prédéterminée par rapport à l'élément de montage (10), de telle sorte que le cordon (7,8) dans la position montée du dispositif écran (1) présente une tension appropriée pour le guidage parallèle, lorsque chacun des premiers repères (12) associés aux ressorts de tension (9) coïncide essentiellement avec le second repère (11) à la position prédéterminée par rapport à l'élément de montage (10).

2. Dispositif écran (1) selon la revendication 1, **caractérisé en ce que** chaque ressort de tension (9) est associé à un premier repère (12) et **en ce que** deux ou plusieurs seconds repères (11) sont prévus à des positions prédéterminées par rapport à l'élément de montage (10).

3. Dispositif écran (1) selon l'une des revendications 1-2, **caractérisé en ce que** les éléments de montage (10) sont positionnés à l'extrémité (4) adaptée pour être fixée sur l'élément entourant l'ouverture (6) et **en ce que** les éléments de montage (10) et ladite extrémité (4) sont positionnés en haut par rapport à l'ouverture (6).

4. Dispositif écran (1) selon l'une des revendications 1-3, **caractérisé en ce que** les seconds et premiers repères de coïncidence (11, 12) sont visibles pendant le processus d'installation et cachés lorsque le dispositif écran est utilisé, par exemple, au moyen d'un couvercle (13).

5. Dispositif écran (1) selon l'une des revendications 1-4, **caractérisé en ce que** le second repère (11) à la position prédéterminée par rapport à l'élément de montage (10) est une butée arrêtant la tension du ressort de tension (9) pendant le montage du dispositif écran (1), lorsque le cordon (7, 8) présente une tension appropriée pour le guidage parallèle.

6. Dispositif écran (1) selon l'une des revendications 1-5, **caractérisé en ce que** lors de l'utilisation l'extrémité libre(5) de l'élément écran (2) peut être amenée dans une position entre les première et seconde positions, cela étant obtenu au moyen d'une friction appropriée entre les cordons (7, 8) et l'extrémité libre

(5), ladite friction appropriée étant atteinte lorsque les cordons (7, 8) présentent une tension appropriée pour le guidage parallèle.

7. Dispositif écran (1) selon l'une des revendications 1-6, **caractérisé en ce que** les côtés longitudinaux (3) de l'élément écran (2) sont guidés dans des rails (15) montés au niveau des côtés de l'ouverture (6). 5
8. Dispositif écran (1) selon l'une des revendications 1-7, **caractérisé en ce que**, pendant le transport et l'installation du dispositif écran (1), au moins un moyen de fixation (14) est fourni pour fixer l'extrémité libre (5) de l'élément écran (2) à son extrémité fixe (4). 10
15
9. Procédé pour monter un dispositif écran (1) selon l'une des revendications 1-8, **caractérisé en ce que** l'extrémité fixe (4) est montée sur l'élément entourant l'ouverture (6), les cordons (7, 8) sont tendus en tirant jusqu'à ce que chacun des premiers repères (12) sur chaque ressort de tension (9) coïncide essentiellement avec son second repère de coïncidence (11) à la position prédéterminée par rapport à l'élément de montage (10), et que les cordons (7, 8) soient fixés dans cette position. 20
25
10. Procédé selon la revendication 9, **caractérisé en ce que** les moyens de fixation (14) destinés à fixer l'extrémité libre (5) de l'élément écran (2) à son extrémité fixée (4) sont détachés après l'installation. 30
11. Procédé selon la revendication 9 ou 10, **caractérisé en ce que** les cordons (7, 8) pendant le transport et/ou pendant une partie du montage sont fixés aux moyens de fixation (14). 35
12. Procédé selon l'une des revendications 9-11, **caractérisé en ce que** les cordons (7, 8) sont raccourcis après avoir été tendus et fixés. 40

45

50

55

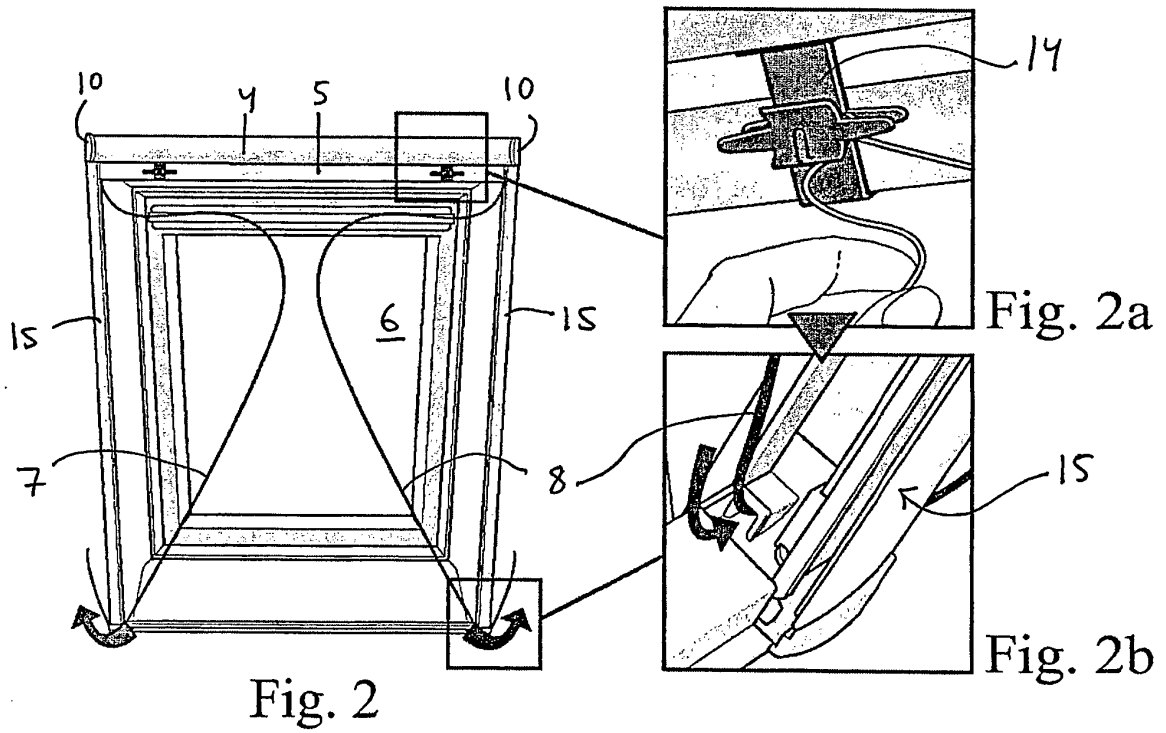
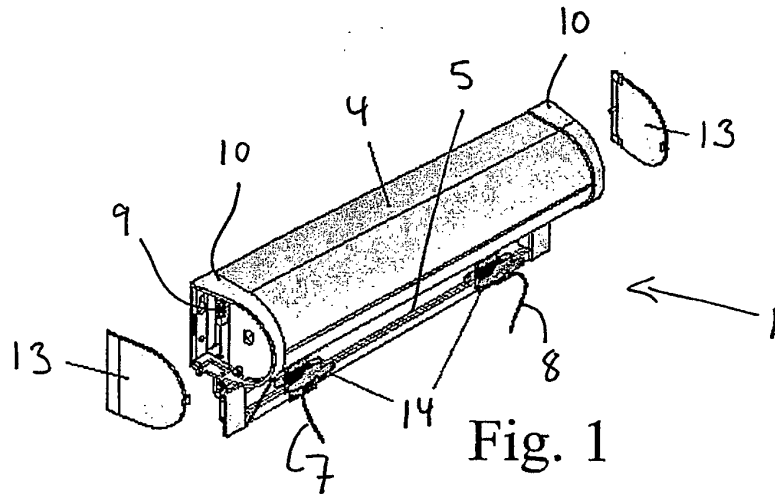

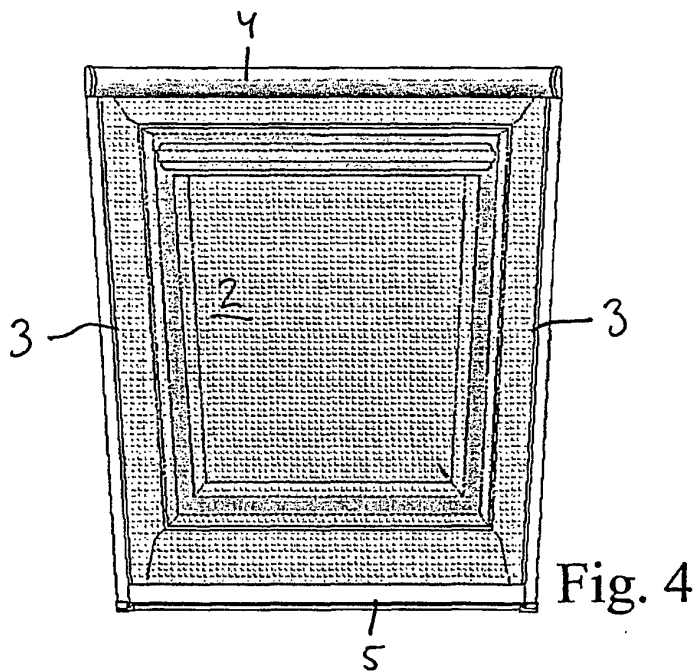
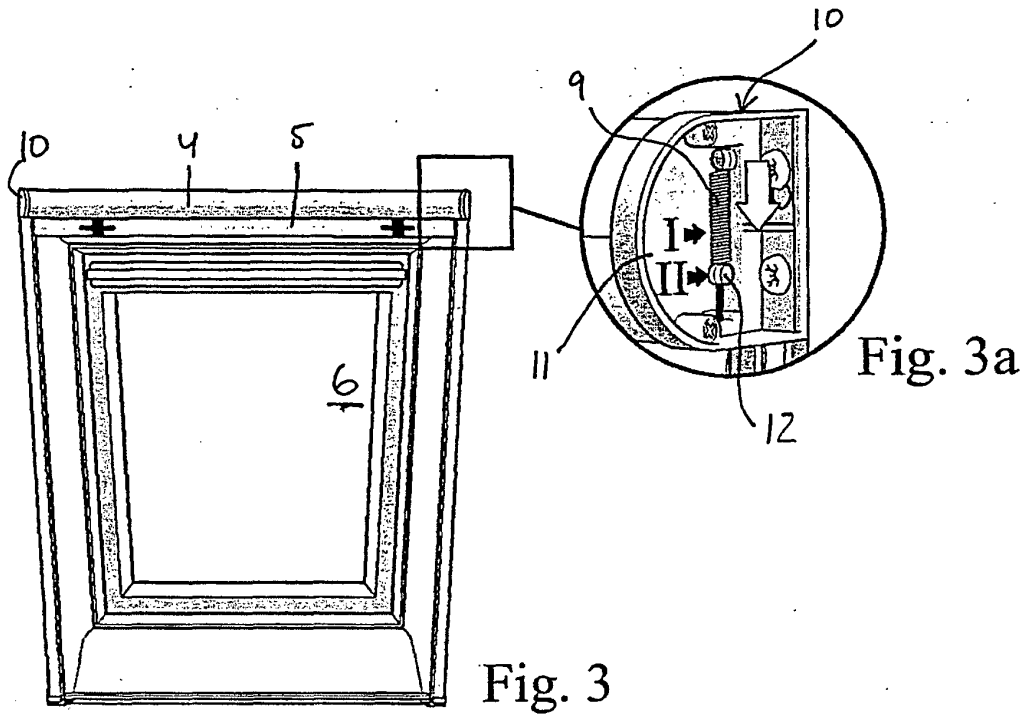

REFERENCES CITED IN THE DESCRIPTION

This list of references cited by the applicant is for the reader's convenience only. It does not form part of the European patent document. Even though great care has been taken in compiling the references, errors or omissions cannot be excluded and the EPO disclaims all liability in this regard.

Patent documents cited in the description

- EP 0960253 A [0002]