

(19) World Intellectual Property Organization
International Bureau



(43) International Publication Date
22 June 2006 (22.06.2006)

PCT

(10) International Publication Number
WO 2006/065926 A1

- (51) International Patent Classification:
A61M 25/00 (2006.01) A61F 2/06 (2006.01)
- (21) International Application Number:
PCT/US2005/045282
- (22) International Filing Date:
14 December 2005 (14.12.2005)
- (25) Filing Language: English
- (26) Publication Language: English
- (30) Priority Data:
60/636,192 15 December 2004 (15.12.2004) US

(71) Applicant (for all designated States except US): **COOK INCORPORATED** [US/US]; 750 N. Daniels Way, Bloomington, IN 47404 (US).

(72) Inventor; and

(75) Inventor/Applicant (for US only): **LENTZ, David, Christian** [US/US]; 4178 South Derby Drive, Bloomington, IN 47401 (US).

(74) Agent: **COPELAND, Trevor, K.**; Brinks Hofer Gilson & Lione, P.O. Box 10087, Chicago, IL 60610 (US).

(81) Designated States (unless otherwise indicated, for every kind of national protection available): AE, AG, AL, AM, AT, AU, AZ, BA, BB, BG, BR, BW, BY, BZ, CA, CH, CN, CO, CR, CU, CZ, DE, DK, DM, DZ, EC, EE, EG, ES, FI, GB, GD, GE, GH, GM, HR, HU, ID, IL, IN, IS, JP, KE, KG, KM, KN, KP, KR, KZ, LC, LK, LR, LS, LT, LU, LV, LY, MA, MD, MG, MK, MN, MW, MX, MZ, NA, NG, NI, NO, NZ, OM, PG, PH, PL, PT, RO, RU, SC, SD, SE, SG, SK, SL, SM, SY, TJ, TM, TN, TR, TT, TZ, UA, UG, US, UZ, VC, VN, YU, ZA, ZM, ZW.

(84) Designated States (unless otherwise indicated, for every kind of regional protection available): ARIPO (BW, GH, GM, KE, LS, MW, MZ, NA, SD, SL, SZ, TZ, UG, ZM, ZW), Eurasian (AM, AZ, BY, KG, KZ, MD, RU, TJ, TM), European (AT, BE, BG, CH, CY, CZ, DE, DK, EE, ES, FI, FR, GB, GR, HU, IE, IS, IT, LT, LU, LV, MC, NL, PL, PT, RO, SE, SI, SK, TR), OAPI (BF, BJ, CF, CG, CI, CM, GA, GN, GQ, GW, ML, MR, NE, SN, TD, TG).

Published:

- with international search report
- before the expiration of the time limit for amending the claims and to be republished in the event of receipt of amendments

For two-letter codes and other abbreviations, refer to the "Guidance Notes on Codes and Abbreviations" appearing at the beginning of each regular issue of the PCT Gazette.

(54) Title: MULTIFILAR CABLE CATHETER

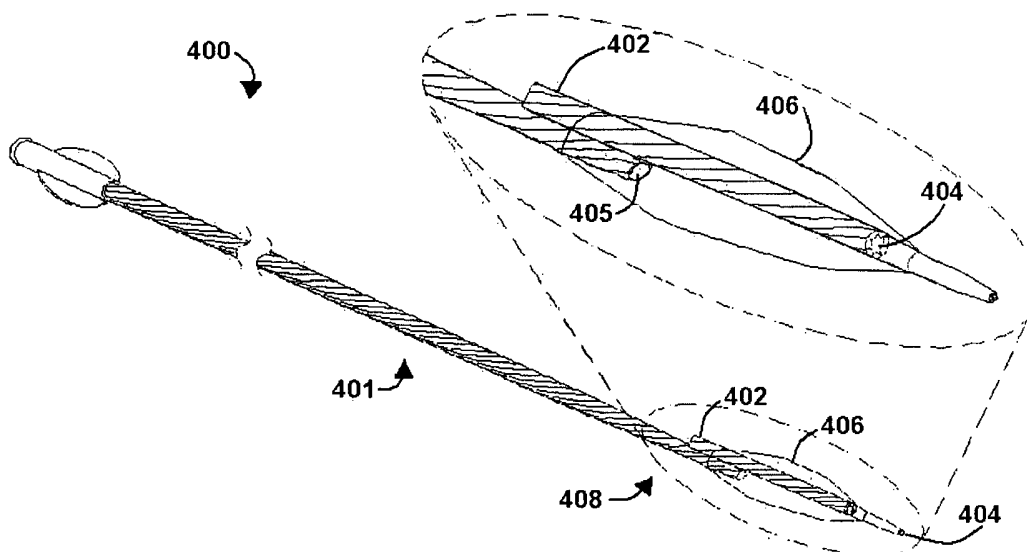

(57) Abstract: A catheter device including an elongate catheter shaft comprising a multifilar cable tubing having a proximal portion and a distal portion. At least a part of the distal portion is more flexible than the proximal portion.

WO 2006/065926 A1

MULTIFILAR CABLE CATHETER

CROSS-REFERENCE TO RELATED APPLICATIONS

[0001] This application claims priority to U.S. Provisional Application Ser. No. 60/636,192, filed December 15, 2004.

TECHNICAL FIELD

[0002] The present application relates to medical catheters, and more specifically to medical catheters useful in endovascular and other body lumens.

BACKGROUND

[0003] Medical delivery catheters are well known in the art of minimally invasive surgery for introduction of fluids and devices to sites inside a patient's body. For example, balloon dilation of luminal stenoses (e.g., in procedures such as angioplasty or balloon dilation of a bile duct), stent placement, and introduction of radio-opaque contrast fluids are common uses of catheters.

[0004] The most widely used form of angioplasty makes use of a dilation catheter having an inflatable balloon at its distal end. In coronary procedures, a hollow guide catheter or wire guide typically is used for guiding the dilation catheter through the vascular system to a position near the stenosis (e.g., to a coronary arterial lumen occluded by plaque). Using fluoroscopy, the physician guides the dilation catheter the remaining distance through the vascular system until a balloon is positioned to cross the stenosis. The balloon is then inflated by supplying pressurized fluid, through an inflation lumen in the catheter, to the balloon. Inflation of the balloon causes a widening of the lumen of the artery to reestablish acceptable blood flow through the artery. In some cases, a stent may be deployed with or instead of the balloon to widen and hold open the occluded arterial lumen.

[0005] Preferably a catheter used in endovascular lumens will have several physical characteristics. The profile and shaft size of the dilation catheter should be such that the catheter can reach and cross a very tight stenosis. Portions of the dilation catheter must also be sufficiently flexible to pass through a tight curvature or tortuous passageway, especially in a catheter adapted for use in the coronary arteries. The ability of a catheter to bend and advance effectively through the endovascular or other lumens is commonly referred to as the "trackability of the catheter." Another important feature of a dilation catheter is its "pushability." Pushability involves the transmission of longitudinal forces along the catheter from its proximal end to its distal end so that a physician can push the catheter through the vascular or other luminal system and the stenoses. Effective catheters should be both trackable and pushable.

[0006] Two commonly used types of dilation catheters are referred to as "long-wire" catheters and "short-wire" catheters. A long-wire catheter is one in which a wire guide lumen is provided through the length of the catheter that is adapted for use with a wire guide that can first be used to establish the path to and through a stenosis to be dilated. The dilation catheter can then be advanced over the wire guide until the balloon on the catheter is positioned within the stenosis.

[0007] In short-wire catheters, the wire guide lumen may not extend the entire length of the catheter. In this type of catheter, the wire guide lumen may extend only from the distal end of the balloon to a point intermediate the distal and proximal ends of the catheter. This shorter lumen is the only portion of the catheter contacting the wire guide. It is sometimes desirable to exchange this first catheter and/or balloon for a second catheter (e.g., to "exchange out" a balloon catheter, and then "exchange in" a stent-deployment catheter). The exchange is preferably executed by leaving the wire guide in place during removal of the first catheter and using it as a guide for the second catheter. The first catheter is withdrawn or otherwise

removed over the wire guide, and then a second catheter is introduced over the wire guide.

[0008] Short-wire catheters are often easier to exchange than catheters having the wire guide lumen extending the entire length of the catheter. This is because the wire guide need not be as long as a "long wire" configuration, which requires that a length of the wire guide extending outside the patient's body be longer than the portion of the catheter extending over the long wire guide in order for a doctor or assistant to maintain a grasp on the wire guide (to avoid undesired movement or displacement thereof). The short wire guide configuration catheters also create less friction during mounting and exchange operations due to the shorter wire guide lumen, leading to a reduced likelihood of displacing the wire guide.

[0009] Catheters for use in endovascular lumens typically require a variation in physical properties along different portions thereof. For example, a certain degree of stiffness is required for pushability and trackability near the proximal end while distal end requires a great deal of flexibility. A catheter having uniform properties throughout its length poses disadvantages in that it is likely to be too proximally flexible or too distally stiff. As a result, most catheter shafts (especially endovascular catheters) are made from multiple materials along the shaft length. For example, a catheter shaft may have a stiff proximal portion made of metal hypotube, a middle portion made of a stiff plastic, and a distal portion made of a more flexible plastic. This combination of materials poses problems of cost and efficiency in construction, and the junctions provide problematic possibilities for structural failure (such as binding, kinking, or even separation) as well as requiring specialized connection means. In another example, a catheter shaft may be made of plastic for a major part of its length, but have a stiffening wire disposed through a significant portion of that length to enhance stiffness. Some long wire catheters rely almost wholly on placement of a wire guide therethrough to retain the needed

stiffness, which presents the problems of length and unwieldiness discussed above. In contrast, the proximal sections of short wire catheters must have adequate stiffness independent of the wire guide.

[0010] Several different structures for shortened guide wire lumen dilation catheters have been proposed and used to obtain the desired physical properties described above, but each of these structures tends to suffer from several disadvantages. For example, in a short wire catheter having a relatively flexible one-piece plastic design, because only a small portion of the wire guide extends through the catheter body near the distal end of the catheter shaft, the wire guide portion does not contribute to the pushability of the rest of the catheter shaft. As a result, the proximal shaft portion of such a catheter has low column strength. With such a configuration, the shafts and guide wire may tend to develop undesirable flexure (e.g., scissoring, bowing, buckling, kinking) when the balloon is being manipulated in a lumen. This undesired flexure may cause an irregular exterior surface such as a sharp edge which can in turn cause injurious abrasions to the inner lining of the artery or other lumen (e.g. other body lumen or a working lumen of an endoscope). This undesired flexure also leads to poor pushability and trackability of the catheter. To counteract this deficiency, some known designs have extended the length of the wire guide lumen and/or provided additional stiffener elements in the shaft.

[0011] In one design, a significant proximal portion of the catheter shaft is made of a metallic tubing (commonly referred to as a hypotube), which provides the desired pushability while maintaining a relatively small outer diameter. The distal portion of the catheter shaft is a second, more flexible (commonly plastic) tubing. In short-wire catheters using the hypotube design, a first aperture for introduction of a wire guide to the wire guide lumen is usually placed in the hypotube near to the distal end thereof. Alternatively, this first aperture is placed in the second tubing, or near the juncture between the hypotube and second tubing. These types of

catheters, however, present certain disadvantages. Having the first aperture in the hypotube mitigates the advantages of a short-wire catheter: the wire guide must be longer, and advantages conferred by reduced friction are lessened. Having the first aperture at the aforementioned junction or in the second tubing creates a likelihood of undesired flexure (e.g., kinking or bunching) as there will be at least some portion of the more flexible second tubing unsupported by a wire guide, and therefore lacking column strength. Not only may such undesired flexure injure an endovascular or other lumen housing the catheter, but it may close off an inflation lumen or other lumen of the catheter, which is undesirable. The problems of increased cost of assembly and various mechanical problems presented by constructing and using a catheter having both semi-flexible hypotube and more flexible second tubing portions of the same catheter are addressed in the present invention.

BRIEF SUMMARY

[0012] The present invention provides a catheter device, adaptable for use in endovascular lumens or other body lumens, that has a construction of multifilar cable tubing for a substantial portion of its length and that is adaptable for use in a short-wire or long-wire configuration. The embodiments described and claimed herein provide a catheter shaft having good pushability and trackability. Embodiments of the present invention are adaptable for a variety of applications (e.g., placement of expandable stents, balloon dilation of stenoses) and use in a variety of surgical locations (e.g., vascular, gastroenterological).

[0013] The embodiments herein are adaptable for use in a variety of minimally invasive surgical treatments (including, e.g., angioplasty or bile duct dilation).

BRIEF DESCRIPTION OF THE DRAWINGS

[0014] FIG. 1A is a perspective view of a catheter, with an enlarged detail view of the catheter's distal end;

[0015] FIG. 1B is a perspective view of a tapered catheter device, with an enlarged detail view of the catheter's distal end;

[0016] FIG. 2 is a perspective view of a catheter shaft with a sleeve;

[0017] FIG. 3A is a perspective view of a catheter device having a distal extension and an inflation balloon, with an enlarged detail view of the features at the catheter's distal end;

[0018] FIG. 3B is a perspective view of a catheter device with an inflation balloon;

[0019] FIG. 4A is a perspective view of a catheter device having an external distal wire guide lumen structure, with an enlarged detail view of the features at the catheter's distal end;

[0020] FIG. 4B is a perspective view of a catheter device having an external distal wire guide lumen structure and an inflation balloon, with an enlarged detail view of the features at the catheter's distal end;

[0021] FIG. 4C is a perspective view of a catheter device with a distal dual lumen structure having a wire guide lumen structure and a mounting portion;

[0022] FIGS. 5A-5B show a side view of catheter devices having a distal extension and a wire guide lumen structure;

[0023] FIG. 5C is a side view of a catheter device having an external distal wire guide lumen structure and an inflation balloon;

[0024] FIG. 6 is a side view of a tapered catheter device having an external distal wire guide lumen structure and an inflation balloon;

[0025] FIG. 6A is a detail of FIG. 6 and shows a longitudinal cross-sectional view of the tapering portion and external wire guide lumen of a catheter device;

[0026] FIG. 6B is a detail of FIG. 6 and shows a longitudinal cross-sectional view of the distal portion of the catheter device, with an enlarged detail view of features where the catheter shaft meets the balloon;

[0027] FIG. 6C is a transverse cross-sectional view of a dual-lumen mounting sleeve;

[0028] FIG. 6D is a transverse cross-sectional view along line 6D-6D of FIG. 6B showing two lumens of the catheter device surrounded by a mounting sleeve;

[0029] FIGS. 7A and 7B illustrate a cross-sectional view of another embodiment of a catheter device

[0030] FIG. 8 illustrates a partial cross-sectional view of yet another embodiment of a catheter device.

DETAILED DESCRIPTION

[0031] The presently described embodiments of a multifilar tube catheter shaft are adaptable for use in a variety of minimally invasive surgical applications (e.g. endoscopic procedures, angioplasty).

[0032] FIGS. 1A-1B illustrate an embodiment of a catheter device 100 with a shaft 101 constructed of a multifilar material and having an internal lumen 102. The multifilar tubing described is made of a plurality of wires twisted together and leaving a central lumen. Such multifilar tubing may be obtained, for example, from Asahi-Intecc (Newport Beach, CA). Materials and methods of manufacturing a suitable multifilar tubing are described in Published U.S. Pat. App. 2004/0116833 (Koto et al.), the contents of which are incorporated herein by reference. Use of multifilar tubing in a vascular catheter device is described in U.S. Pat. No. 6,589,227 (Sonderskov Klint, et al.; Assigned to Cook Inc. of Bloomington, Indiana and William Cook Europe of Bjaeverskov, Denmark), which is also incorporated herein by reference.

[0033] In FIG. 1A, the exterior diameter 107 is approximately the same along the length of the shaft 101. In the embodiment shown in FIG. 1B,

the proximal end 104 has a greater exterior diameter than the distal end 106. The catheter shaft 101 tapers toward a smaller exterior diameter 108 at the distal end 106. Tapering can enhance flexibility of the shaft 101 in several ways. For example, flexibility is enhanced by decreasing the outside diameter of the catheter shaft 101. The portion of the catheter shaft 101 having a smaller diameter is more flexible than the portion having a larger diameter. Such tapering also decreases the thickness of the wall of the catheter shaft 101. Alternatively, tapering may be used within the internal diameter of a catheter, enhancing flexibility by decreasing wall thickness without altering the exterior diameter of the shaft 101. The steepness and location of the tapering is determined by the desired application for the catheter shaft 101. For example, in alternative embodiments, there may be multiple stepwise or gradual differences in diameter to confer different degrees of flexibility throughout the length of the catheter. For example, catheter shaft 101 for use in coronary arteries will typically benefit from a smaller diameter than a catheter shaft 101 for use in a bile duct, both for gross size and flexibility. A grinding process or other suitable process may be used to reduce the exterior diameter as appropriate for the desired application. Reducing the exterior diameter provides an added benefit by reducing the profile of the device. The flexibility of the catheter shaft 101 or a portion thereof may also be altered by increasing or decreasing the number of filars. In one aspect, the embodiments described herein also provide a catheter shaft having consistent construction material throughout most of the length of the catheter shaft, with gradual transition from a stiffer proximal end to a more flexible distal end and lacking sharp transitions that undermine structural integrity.

[0034] A further embodiment of the catheter shaft 101 includes a coating on internal and/or external surfaces for at least a portion of the catheter shaft 101. The coating is selected to confer or improve one or more properties of reduced friction, flexibility, and sealing a lumen 102 of

the catheter. Sealing the lumen 102 allows the lumen to be used, for example, for introduction of inflation fluid to a dilation balloon or introduction of a medicative substance or radio-opaque contrast fluid.

[0035] The coating may be, for example, a sheath or sleeve 202 as illustrated in FIG. 2. In various alternative embodiments, the sheath 202 may comprise an extruded sleeve, shrink tube, extruded over-jacket, or dip coat. The sheath 202 is preferably a thermoset material or a thermoplastic material and may comprise, for example, HDPE, PTFE, PEBA, PET, polyurethane, polyimide, polyolefin, nylon, or any combination thereof. The coating may be applied by, for example, over-extrusion, dip-coating, melt fusion, or heat shrinking. For example, PET shrink tube 202 has the advantage of providing an increased stiffness to a small diameter catheter shaft 201. On the other hand, a PEBA (Polyether Block Amide) shrink tube 202 can be used with a larger diameter catheter shaft 201 where greater flexibility is desired. The type of sleeve 202 material may also be selected to complement other catheter components; for example, a nylon sleeve 202 may bond and interact better with a nylon expandable member such as a balloon or basket and/or a nylon wire guide lumen. Selection of coating materials, filar size and number, and diameter allow manipulation of the catheter shaft's 201 shore hardness to offer the desired functional properties.

[0036] FIGS. 3A-3B illustrate embodiments of balloon catheters 300 comprising a multifilar shaft 301. In the embodiment of FIG. 3A, the catheter shaft 301 has a distal extension 302, upon which is mounted an inflation balloon 304. The distal extension 302 can be formed of the same group of materials used in the coating (HDPE, PTFE, PEBA, PET, polyurethane, polyimide, polyolefin, nylon, or any combination thereof) and provides a shaft portion that may be more flexible than the shaft 301. As can clearly be seen in the detail illustration portion of FIG. 3A, the extension 302 encloses an inflation lumen 306 which continues from an inflation lumen 306 of the multifilar catheter shaft 301. The extension 302

also encloses a wire guide lumen 308. In the illustrated long wire configuration catheter 300, the wire guide lumen extends from the proximal end of the multifilar catheter shaft 301 and extends through the inflation balloon 304 at the distal end.

[0037] The embodiment illustrated in FIG. 3B has an inflation balloon 304 disposed directly on the distal end of the catheter shaft 301. An inflation lumen 306 of the multifilar catheter shaft 301 opens into the inflation balloon 304. A wire guide lumen 308 traverses the interior of the balloon 304, continuing the wire guide lumen 308 of the catheter shaft 301 to a point distal of the inflation balloon 304. An expandable stent 312 is positioned about the balloon 304. In an alternative embodiment, an expandable member other than a balloon (e.g., a basket) is disposed near the distal end of the catheter shaft 301. Such an embodiment optionally may have a wire guide through the expandable member. At its proximal end the catheter 300 has a port 310 in fluid communication with the inflation lumen 306. In an alternative embodiment, the port 310 offers access to the guide wire lumen 308. The port 310 may be included in other embodiments, and in other positions on the catheter 300. In another alternative embodiment, the catheter shaft 301 has two ports 310, offering separate access to each of the inflation lumen 306 and the wire guide lumen 308. In other alternative embodiments, the port 310 is useful for introducing another fluid such as a contrast fluid.

[0038] FIGS. 4A-4B illustrate embodiments of a multifilar tube balloon catheter device 400 comprising a multifilar shaft 401 and further comprising an external, distally disposed short wire guide lumen structure in the form of a cannula 402 having a wire guide lumen 404 disposed therethrough. In FIG. 4A, the cannula 402 is attached on the distal end 408 of the multifilar catheter shaft 401 using an adhesive. Alternative means of attachment include, for example, forced convection heating, radio frequency heating, ultrasonic welding, and laser bonding. Alternatively, shrink tubing may be used as a manufacturing aid to help

compress and fuse the cannula 402 to the multifilar catheter shaft 401. The shrink tubing may be removed and disposed of after the cannula 402 is connected to the catheter shaft 401, or may remain on as part of the connected structure. If the multifilar catheter shaft 401 has a coating, the cannula 402 may be bonded to the coating or directly to the catheter shaft 401. A heat shrink tubing, for example PEBA, may be applied over the entire assembly, which increases the strength of the assembly. In the embodiment shown in FIG. 4B, the cannula 402 is constructed of multifilar tubing. An inflation balloon 406 is mounted on the distal end 408 of the catheter shaft 401. An inflation lumen 405 of the catheter shaft 401 is open to the interior of the inflation balloon 406. The cannula 402 extends through the inflation balloon 406 and has an extension 407 on its distal end. A wire guide lumen 404 runs through the length of the cannula 402 and its extension 407. Although not shown, it should be appreciated that an expandable stent can be disposed about the balloon 406. The cannula 402 providing a wire guide lumen structure can be formed of HDPE, PTFE, PEBA, PET, polyurethane, polyimide, polyolefin, nylon, or any combination thereof. In one embodiment, the cannula 402 comprises a PTFE inner liner and a PEBA outer cover. Other materials may be used as an inner liner such as, for example, HDPE, PET, and polyimide.

[0039] In FIG. 4C, a dual lumen structure 410 is disposed on the distal end 408 of the multifilar catheter shaft 401. A portion of the length of dual lumen structure 410 has a "figure 8" cross section. A mounting portion 412 of the dual lumen structure 410 has a lumen 414. The distal end 408 of the catheter shaft 401 fits into the lumen 414. The lumen 414 may be completely occupied by the distal end 408 of the catheter shaft 401, or may continue coaxially beyond the distal end 408 so as to form an extension. If the mounting portion 412 is placed as an extension, the lumen 414 is in fluid communication with a lumen 420 of the shaft 401. A wire guide portion 416 of the dual lumen structure 410 has a wire guide lumen 418 running therethrough. The dual lumen structure 410 is attached

on the distal end 408 of the catheter shaft 401 using one of the attachment methods described for the embodiment shown in FIG. 4A. In this embodiment, the lumen 414 of the dual lumen structure is in fluid communication with a lumen 404 of the catheter shaft 401. In an alternative embodiment, a part of the mounting portion 412 is mounted inside the lumen 420 of the catheter shaft 401.

[0040] FIGS. 5A-5C illustrate embodiments of a balloon catheter 500 incorporating a multifilar shaft 501 and having a short wire guide configuration. The embodiments shown in FIGS. 5A-5B each have a coaxial extension 502 of the multifilar shaft 501, a short wire guide lumen structure in the form of a tube 504, and an inflation balloon 506. The coaxial extension 502 may have the same or a different flexibility than the multifilar shaft 501. In the embodiment illustrated in FIG. 5A, the proximal end 508 of the tube 504 is disposed distal of the juncture of the extension 502 with the multifilar shaft 501. The tube 504 enters the extension 502 and extends through the distal end of the balloon 506. Thus, this embodiment comprises a distal extension of the shaft (in this case the coaxial extension 502) and the wire guide lumen structure 504, a portion of the wire guide lumen structure 504 being coaxial within the distal extension, another portion of the wire guide lumen structure 504 being outside the distal extension adjacent thereto.

[0041] In the embodiment illustrated in FIG. 5B, the proximal end 508 of the tube 504 is disposed proximal of the juncture of the extension 502 with the multifilar shaft 501. The tube 504 enters the extension 502 and proceeds through the distal end of the balloon 506. Thus, this embodiment comprises a distal extension of the shaft (in this case the coaxial extension 502) and the wire guide lumen structure 504, a portion of the wire guide lumen structure being coaxial within the distal extension, another portion of the wire guide lumen structure 504 being outside the shaft adjacent thereto. The embodiment illustrated in FIG. 5C does not have an extension. The balloon 506 is disposed on the distal end of the multifilar shaft 501. The

proximal end 508 of the tube 504 is disposed proximal of the juncture of the extension 502 with the multifilar shaft 501 and is affixed to the exterior of the multifilar shaft 501. The tube 504 passes through the middle of the balloon 506 and proceeds through the distal end of the balloon 506. In each of the embodiments shown in FIGS. 5A-5C, the placement of the proximal end 508 of the tube 504 along the multifilar shaft 501 affects the flexibility of the shaft 501. Therefore, variation in the placement is useful in increasing or reducing flexibility as desired in other embodiments.

[0042] FIG. 6 illustrates one embodiment of a balloon catheter 600 having an elongate shaft 601 comprising a multifilar tube. An inflation balloon 602 is disposed near the distal end. FIG. 6A is an enlarged detail illustration of a middle section of the catheter 600. As can be clearly seen in FIG. 6A, the shaft 601 includes an external wire guide lumen 604 and an internal inflation lumen 606. As shown in FIG. 6A, this embodiment the catheter shaft 601 is coated with a PEBA coating 603. The coating 603 serves to reduce friction during introduction of the catheter shaft 601 and provides a seal to prevent leakage of inflation fluid from the inflation lumen 606 through the walls of the shaft 601. As can also be seen in FIG. 6A, the catheter shaft 601 tapers distally to a smaller diameter along the region 605.

[0043] FIG. 6B is an enlarged detail illustration of a distal section of the balloon catheter 600. As shown in FIG. 6B, the inflation lumen 606 opens into the inflation balloon 602, and the wire guide lumen 604 extends through the balloon 602 to the distal end 607. FIG. 6B includes an enlarged detail portion more clearly illustrating the relationship between the balloon 602 and the two lumens (604 and 606). In this embodiment, the balloon 602 and wire guide lumen 604 are mounted to the shaft 601 with a PEBA shrink sleeve 608. As shown in FIG. 6C, a cross-sectional view of the sleeve 608 has approximately a figure-eight shape before mounting. The sleeve 608 has two central apertures (610 and 612) to allow mounting the sleeve 608 over the wire guide lumen 604 and the shaft. In this

embodiment, after the balloon 602 and wire guide 604 are assembled to the shaft 601 together with the sleeve 608, the sleeve 608 is heated to shrink and form to the assembly of shaft 601, balloon 602, and wire guide 604. FIG. 6D is a transverse cross section along line 6D-6D of FIG. 6B, and shows the finished configuration. The sleeve 608 forms to the shaft 601 and leaves open the inflation lumen 606 and the wire guide lumen 604.

[0044] Cross-lumen communication may be prevented. For example, the walls of the multifilar tube of the elongate shaft 601 may be porous, and pressure exerted on an inflation fluid in the inflation lumen 606 may urge inflation fluid into the wire guide lumen 604. According to one aspect, this may be prevented by lining the wire guide lumen 604 with a liner such as, for example, PTFE, although other materials may be used.

Furthermore, an inner coating segment may be placed over the elongate shaft 601 beneath the proximal breach or side opening of the wire guide lumen 604. The inner coating segment may be, for example, PEBA. The inner coating segment may be implemented to alter flexibility in the area of the segment, for example to avoid abrupt changes in flexibility. In one embodiment, the proximal end of the segment terminates at about halfway through the taper and the distal end of the segment terminates just distal of the proximal breach or side opening of the wire guide lumen 604.

According to another aspect, cross-lumen communication may be prevented by placing the coating 603 over essentially the entire length of the elongate shaft 601, and the sleeve 608 may subsequently be placed over the coating 603 and elongate shaft 601. According to yet another aspect, cross-lumen communication may be prevented by simply making the walls of the sleeve 608 thicker. A 0.001 inch (0.025 mm) wall thickness of the coating 603 or sleeve 608, for example, may be sufficient. As mentioned previously, the coating 603 and sleeve 608 may be PEBA. These principles may be implemented in other embodiments of the

invention as may be desirable due to fluid being passed through or injected into one of the lumens.

[0045] FIGS. 7A-7B illustrate a cross-sectional view of a portion of a catheter device 700 according to one aspect of the present invention. A shaft wall comprising multiple filars 702 includes an inner coating 701 and an outer coating 703, and surrounds a first lumen 704 and a second lumen 706. A wire guide 708 extends through the first lumen 704, and a stent-deployment shaft 710 extends through the second lumen 706. As shown in FIG. 7A, the catheter device 700 includes a distal extension 712 that houses a self-expandable stent 714. FIG. 7B illustrates the stent 714 having been pushed out of the second lumen 706 by the stent-deployment shaft 710 such that the stent 714 is deployed. Prior to deployment of the stent 714, the wire guide 708 is typically retracted into the shaft wall or lumen 704 so as not to interfere with deployment of the stent 714.

[0046] FIG. 8 illustrates a partial cross-sectional view of another embodiment of a catheter device 800, including a self-expanding stent 810. The catheter device 800 has a central lumen 802 surrounded by a first, outer tubular multifilar body 804. A second, inner multifilar cable tube is coaxially disposed in the central lumen 802 for use as a pusher 806. The pusher 806 has a protruding engagement surface 808 for pushing the self-expanding stent 810 out of the central lumen 802 or for holding the stent 810 as the outer tubular multifilar body 804 is being pulled in a proximal direction. A tapered tip 12 is mounted on the distal end of the pusher 806, and provides a minimally traumatic leading surface for the catheter device 800. A wire guide 814 extends through a central wire guide lumen 816 of the pusher 806. Optionally, apertures (not shown) may be provided through the side of the outer tubular body 804 and the pusher 806 to permit the wire guide 814 to exit the central lumen 802 and the wire guide lumen 816 at an intermediate location. The self-expanding stent 810 is adapted to be deployed when a user retracts the outer tubular body 804 proximally while holding the pusher 806 substantially in place. The

protruding engagement surface 808 of the pusher 806 holds the self-expanding stent 810 substantially in place while the outer tubular body 804 is withdrawn from around it. Once the stent 810 is deployed, the pusher 806 and wire guide 814 are withdrawn, leaving the stent 810 in the position where it was deployed.

[0047] In alternative embodiments, the shaft coating (if any) may be a material other than PEBA, and may be the same or different than the material in a mounting sleeve used to mount a balloon (for example, HDPE, PTFE, PET, polyurethane, polyimide, polyolefin, nylon, or any combination thereof). In other alternative embodiments, the multifilar catheter shaft need not have a lumen running through its length, but may be relatively solid (e.g., for use as a pushing tool, or for use in a configuration not requiring a lumen through the catheter shaft). The balloon catheters of the present invention are adaptable for use with expandable stents as is illustrated, for example, in FIG. 3B.

[0048] It is therefore intended that the foregoing detailed description be regarded as illustrative rather than limiting, and that it be understood that it is the following claims, including all equivalents, that are intended to define the spirit and scope of this invention.

CLAIMS

We claim

1. A catheter device, comprising:
an elongate catheter shaft comprising a multifilar tubing having a proximal portion and a distal portion wherein at least a part of the distal portion is more flexible than the proximal portion.
2. The catheter device of claim 1, the multifilar tubing defining a first lumen, and further comprising a second lumen.
3. The catheter device of claim 2, wherein at least one of the first and second lumens is adapted for passage of a wire guide.
4. The catheter device of claim 1, further comprising a distal extension of the shaft.
5. The catheter device of claim 4, further comprising a wire guide lumen disposed upon at least the distal extension.
6. The catheter device of claim 1, further comprising a distal extension of the shaft and a wire guide lumen, a portion of the wire guide lumen being coaxial within the distal extension, another portion of the wire guide lumen being outside the distal extension adjacent thereto.
7. The catheter device of claim 1, further comprising a distal extension of the shaft and a wire guide lumen, a portion of the wire guide lumen being coaxial within the distal extension, another portion of the wire guide lumen being outside the shaft adjacent thereto.
8. The catheter device of claim 1, the multifilar tubing defining a first lumen, and further comprising
a self-expanding stent;
a second lumen;
and a stent deployment shaft disposed in the second lumen.
9. The catheter device of claim 1, further comprising a polymeric coating, said coating covering at least a region of the shaft.
10. The catheter device of claim 9, further comprising an expandable balloon.
11. The catheter device of claim 10, wherein the balloon comprises the same polymer as the coating.

12. The catheter device of claim 1, further comprising at least one of an inflation lumen or an expandable member disposed at a distal end of the shaft.
13. The catheter device of claim 12, further comprising a deployable stent disposed about the expandable member.
14. The catheter device of claim 12, wherein the expandable member comprises a balloon.
15. The catheter device of claim 14, comprising the inflation lumen and wherein the inflation lumen is in fluid communication with a lumen of the balloon.
16. The catheter device of claim 12, wherein the expandable member comprises an expandable basket.
17. The catheter device of claim 1, further comprising a self-expanding stent.
18. The catheter device of claim 1, further comprising an external wire guide lumen attached near the distal end.
19. The catheter device of claim 1, further comprising an external wire guide lumen mounted near the distal end, wherein the wire guide lumen is disposed through at least a portion of an expandable balloon lumen of a balloon attached to the distal portion.
20. The catheter device of claim 1, further comprising a balloon-deployable stent.
21. A catheter device, comprising:
 - an elongate catheter shaft comprising a multifilar tubing having a proximal portion and a distal portion, the multifilar tubing defining a first lumen, and further comprising a second lumen.
22. The catheter device of claim 21, wherein at least a part of the distal portion is more flexible than the proximal portion.
23. The catheter device of claim 21, wherein at least one of the first and second lumens is adapted for passage of a wire guide.
24. The catheter device of claim 21, further comprising a distal extension of the shaft.
25. The catheter device of claim 24, wherein said second lumen is a wire guide lumen disposed upon at least the distal extension.
26. The catheter device of claim 21, further comprising a distal extension of the shaft, the second lumen being a wire guide lumen, a portion of the wire guide

lumen being coaxial within the distal extension, another portion of the wire guide lumen being outside the distal extension adjacent thereto.

27. The catheter device of claim 21, further comprising a distal extension of the shaft, the second lumen being a wire guide lumen, a portion of the wire guide lumen being coaxial within the distal extension, another portion of the wire guide lumen being outside the shaft adjacent thereto.

28. The catheter device of claim 21, the multifilar tubing defining a first lumen, and further comprising

a self-expanding stent;

and a stent deployment shaft disposed in the second lumen.

29. The catheter device of claim 21, further comprising a polymeric coating, said coating covering at least a region of the shaft.

30. The catheter device of claim 29, further comprising an expandable balloon.

31. The catheter device of claim 30, wherein the balloon comprises the same polymer as the coating.

32. The catheter device of claim 21, further comprising at least one of an inflation lumen or an expandable member disposed at a distal end of the shaft.

33. The catheter device of claim 32, further comprising a deployable stent disposed about the expandable member.

34. The catheter device of claim 32, wherein the expandable member comprises a balloon.

35. The catheter device of claim 34, comprising the inflation lumen and wherein the inflation lumen is in fluid communication with a lumen of the balloon.

36. The catheter device of claim 32, wherein the expandable member comprises an expandable basket.

37. The catheter device of claim 21, further comprising a self-expanding stent.

38. The catheter device of claim 21, the second lumen being an external wire guide lumen attached near the distal end.

39. The catheter device of claim 21, the second lumen being an external wire guide lumen mounted near the distal end, wherein the wire guide lumen is disposed through at least a portion of an expandable balloon lumen of a balloon attached to the distal portion.

40. The catheter device of claim 21, further comprising a balloon-deployable stent.

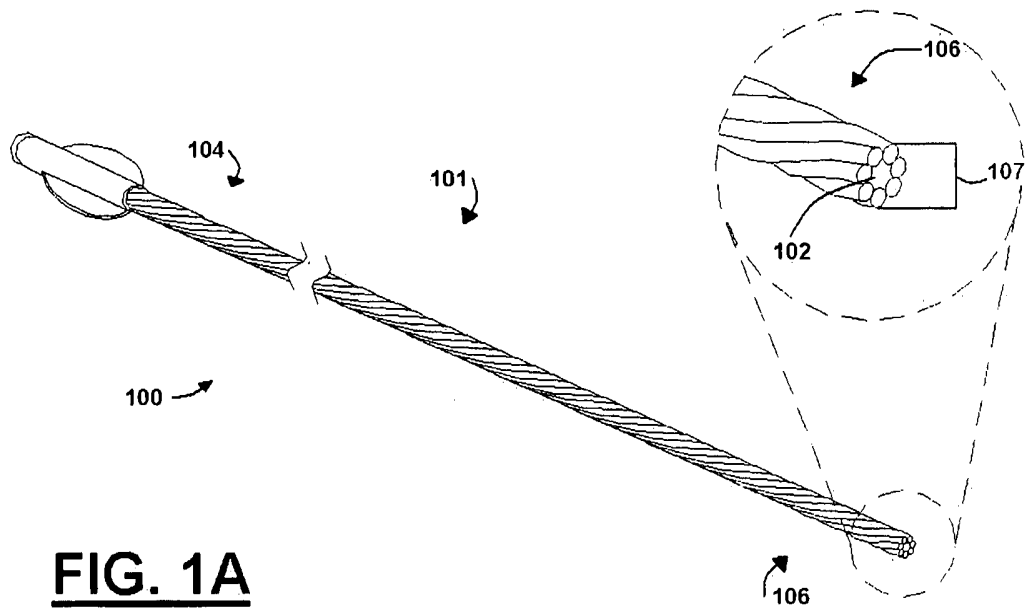

FIG. 1A

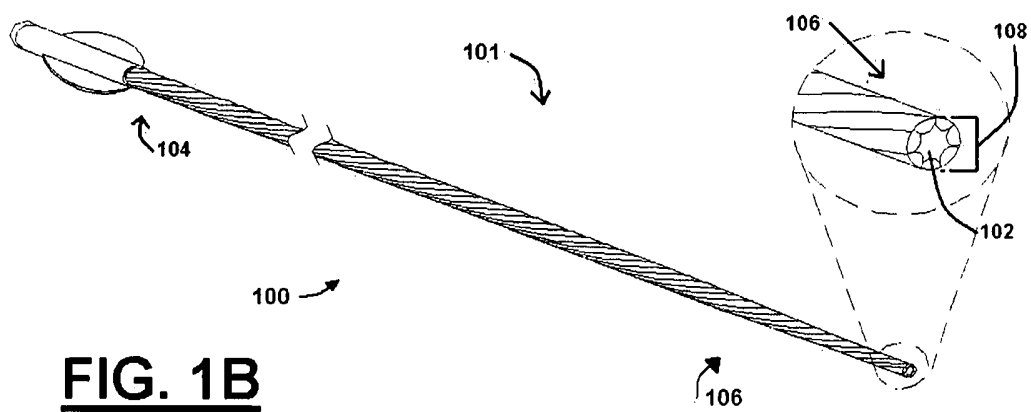

FIG. 1B

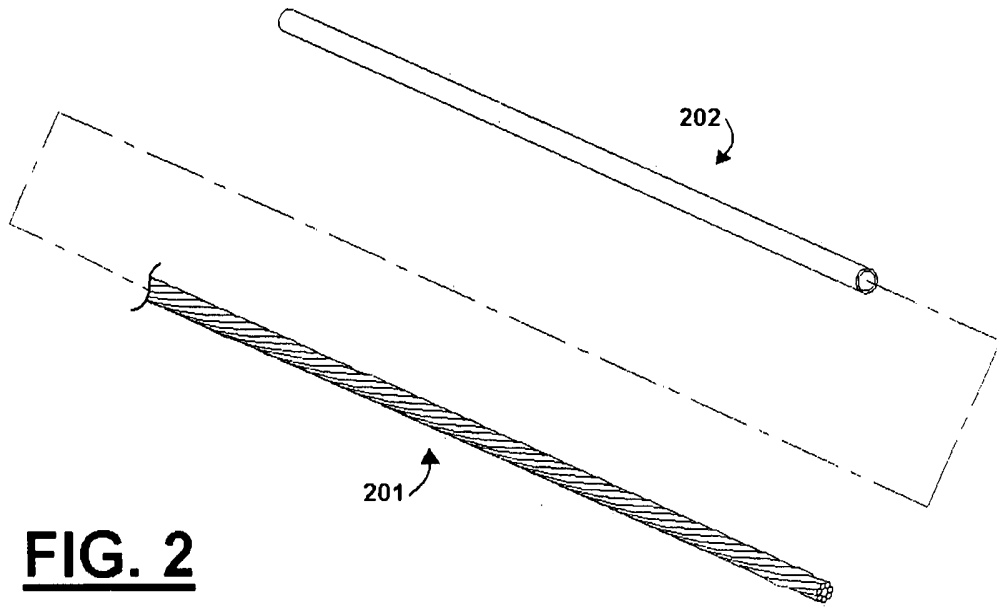

FIG. 2

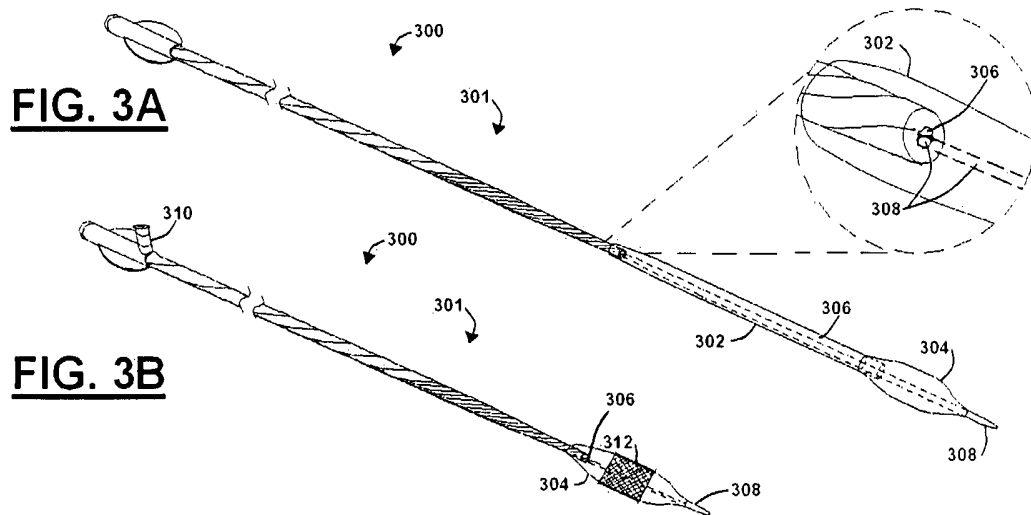

FIG. 3A

FIG. 3B

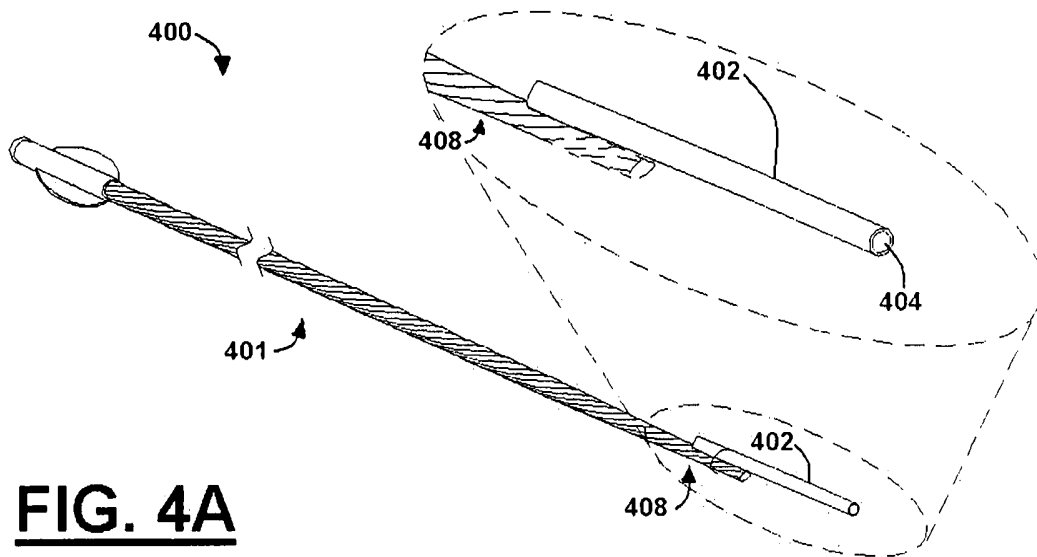

FIG. 4A

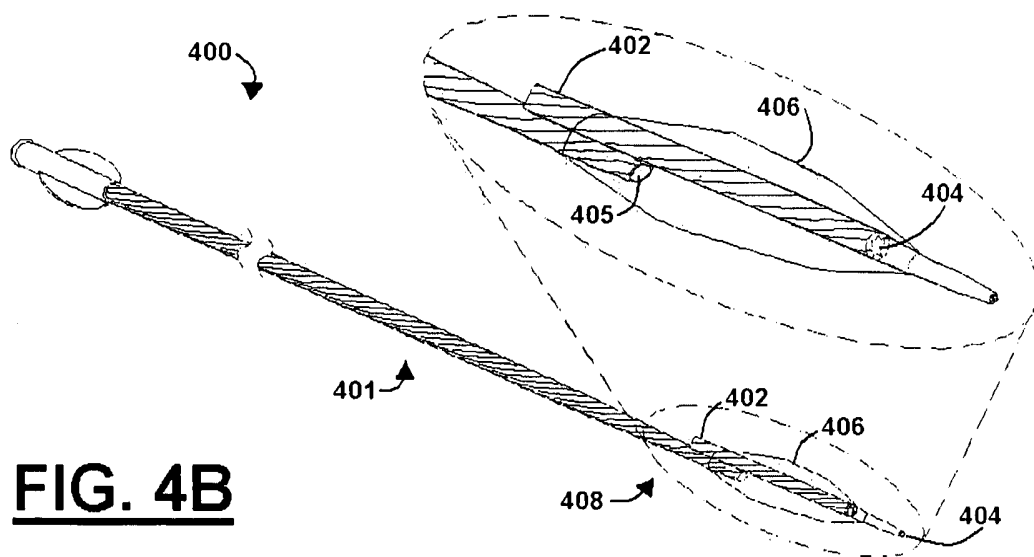

FIG. 4B

4/7

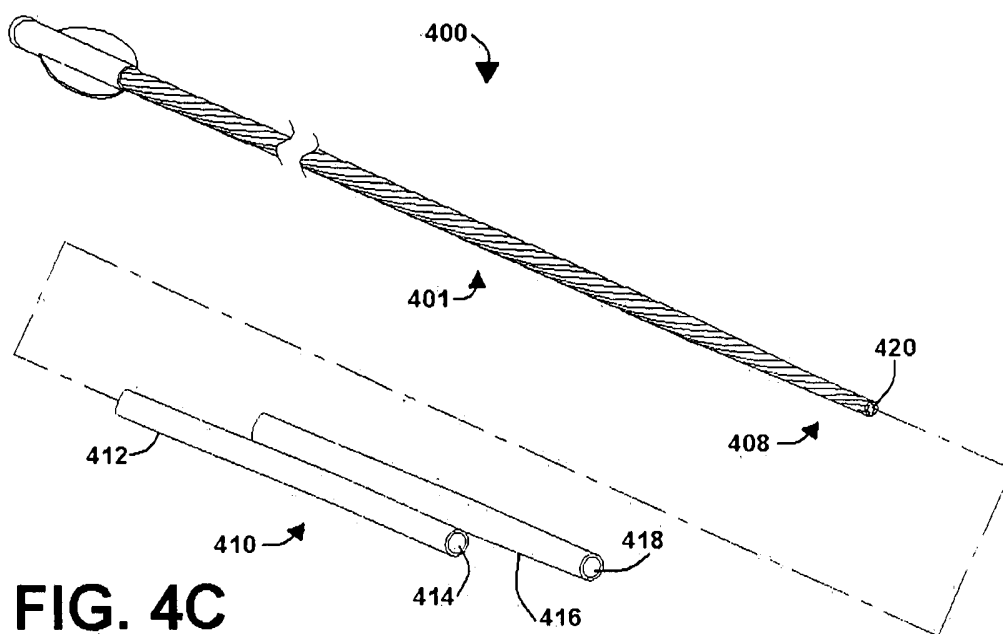

FIG. 4C

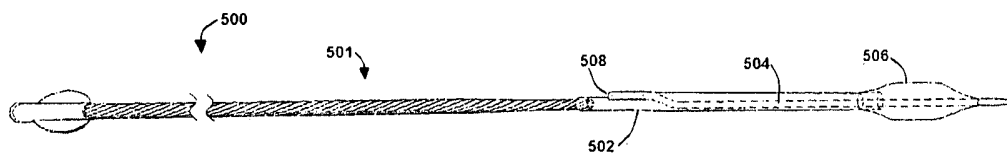

FIG. 5A

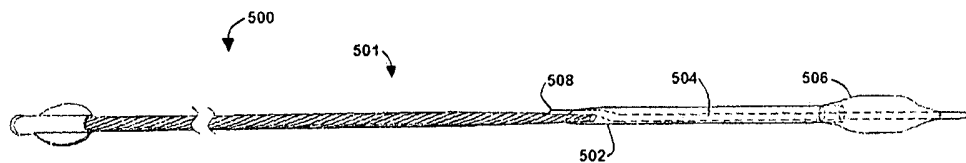

FIG. 5B

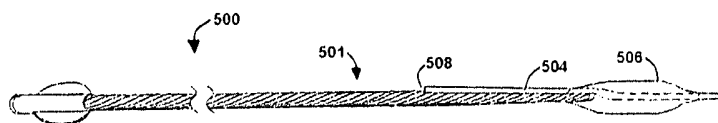

FIG. 5C

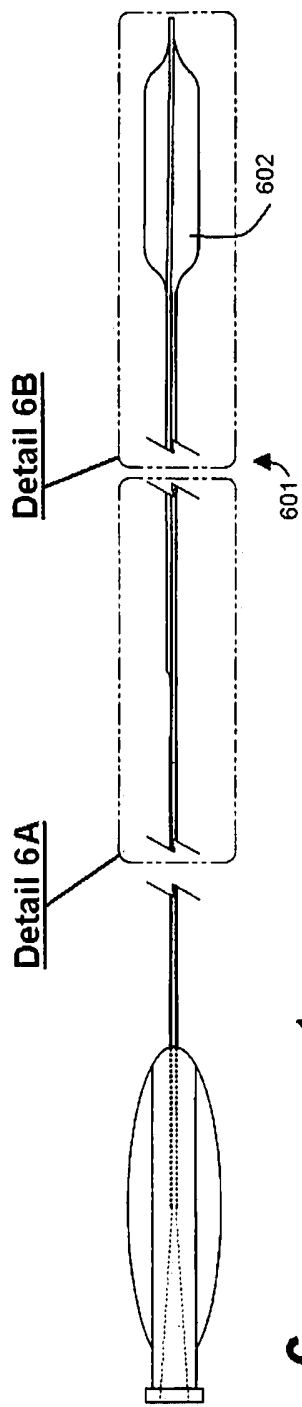

FIG. 6

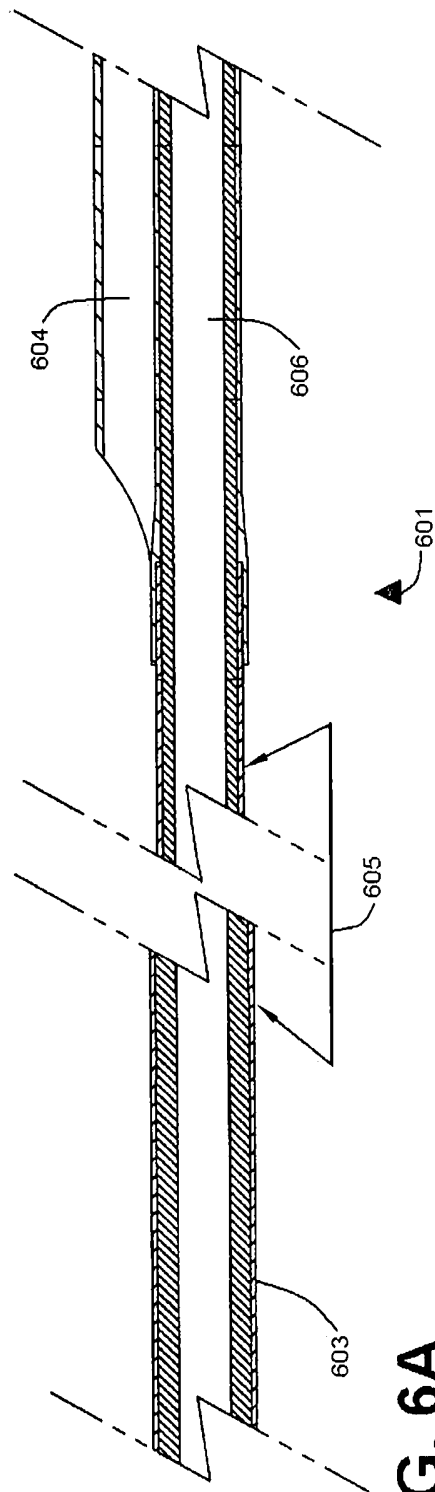

FIG. 6A

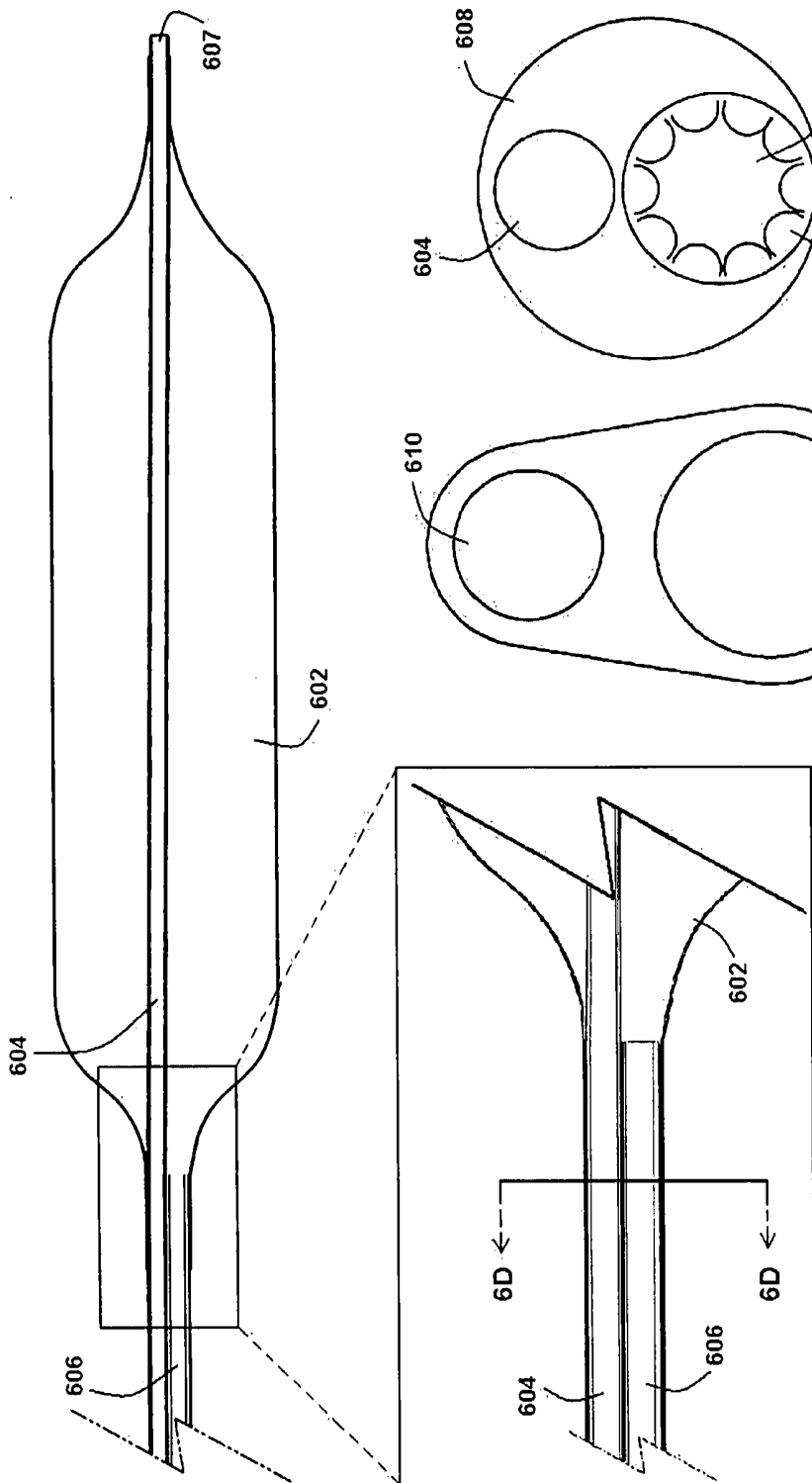

FIG. 6D

FIG. 6C

FIG. 6B

7/7

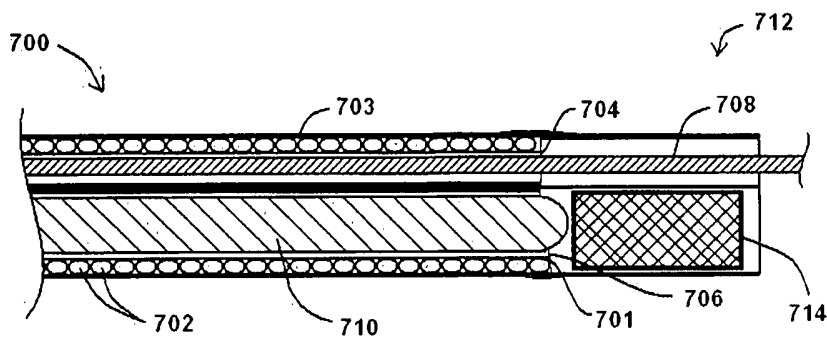

FIG. 7A

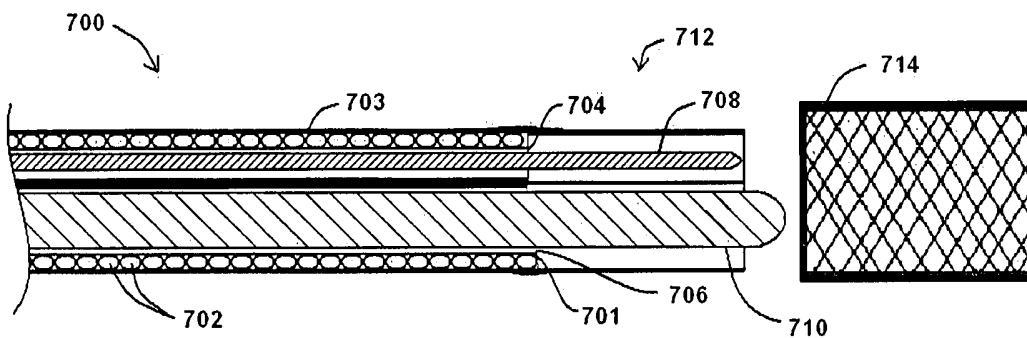

FIG. 7B

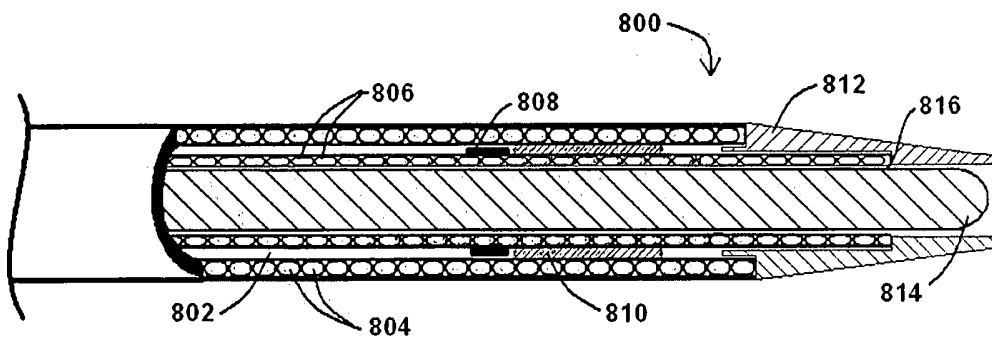

FIG. 8

INTERNATIONAL SEARCH REPORT

International application No
PCT/US2005/045282

A. CLASSIFICATION OF SUBJECT MATTER A61M25/00 A61F2/06				
According to International Patent Classification (IPC) or to both national classification and IPC				
B. FIELDS SEARCHED				
Minimum documentation searched (classification system followed by classification symbols) A61M A61F				
Documentation searched other than minimum documentation to the extent that such documents are included in the fields searched				
Electronic data base consulted during the international search (name of data base and, where practical, search terms used) EPO-Internal, PAJ				
C. DOCUMENTS CONSIDERED TO BE RELEVANT				
Category*	Citation of document, with indication, where appropriate, of the relevant passages	Relevant to claim No.		
X	US 6 548 010 B1 (STIVLAND TIMOTHY M ET AL) 15 April 2003 (2003-04-15) the whole document	1-7, 9-12, 14, 15, 18-27, 29-32, 34, 35, 38, 39		
X	US 2004/010243 A1 (KLINT HENRIK SONDERSKOV) 15 January 2004 (2004-01-15) paragraphs [0015] - [0023] paragraphs [0045] - [0110]; figures 1-18 ----- -/--	1, 2, 4, 5, 8-17, 20-24, 28-37, 40		
<table style="width: 100%; border: none;"> <tr> <td style="width: 50%; border: none;"> <input checked="" type="checkbox"/> Further documents are listed in the continuation of Box C </td> <td style="width: 50%; border: none;"> <input checked="" type="checkbox"/> See patent family annex. </td> </tr> </table>			<input checked="" type="checkbox"/> Further documents are listed in the continuation of Box C	<input checked="" type="checkbox"/> See patent family annex.
<input checked="" type="checkbox"/> Further documents are listed in the continuation of Box C	<input checked="" type="checkbox"/> See patent family annex.			
* Special categories of cited documents :				
<table style="width: 100%; border: none;"> <tr> <td style="width: 50%; border: none;"> *A* document defining the general state of the art which is not considered to be of particular relevance *E* earlier document but published on or after the international filing date *L* document which may throw doubts on priority claim(s) or which is cited to establish the publication date of another citation or other special reason (as specified) *O* document referring to an oral disclosure, use, exhibition or other means *P* document published prior to the international filing date but later than the priority date claimed </td> <td style="width: 50%; border: none;"> *T* later document published after the international filing date or priority date and not in conflict with the application but cited to understand the principle or theory underlying the invention *X* document of particular relevance; the claimed invention cannot be considered novel or cannot be considered to involve an inventive step when the document is taken alone *Y* document of particular relevance; the claimed invention cannot be considered to involve an inventive step when the document is combined with one or more other such documents, such combination being obvious to a person skilled in the art. *&* document member of the same patent family </td> </tr> </table>			*A* document defining the general state of the art which is not considered to be of particular relevance *E* earlier document but published on or after the international filing date *L* document which may throw doubts on priority claim(s) or which is cited to establish the publication date of another citation or other special reason (as specified) *O* document referring to an oral disclosure, use, exhibition or other means *P* document published prior to the international filing date but later than the priority date claimed	*T* later document published after the international filing date or priority date and not in conflict with the application but cited to understand the principle or theory underlying the invention *X* document of particular relevance; the claimed invention cannot be considered novel or cannot be considered to involve an inventive step when the document is taken alone *Y* document of particular relevance; the claimed invention cannot be considered to involve an inventive step when the document is combined with one or more other such documents, such combination being obvious to a person skilled in the art. *&* document member of the same patent family
A document defining the general state of the art which is not considered to be of particular relevance *E* earlier document but published on or after the international filing date *L* document which may throw doubts on priority claim(s) or which is cited to establish the publication date of another citation or other special reason (as specified) *O* document referring to an oral disclosure, use, exhibition or other means *P* document published prior to the international filing date but later than the priority date claimed	*T* later document published after the international filing date or priority date and not in conflict with the application but cited to understand the principle or theory underlying the invention *X* document of particular relevance; the claimed invention cannot be considered novel or cannot be considered to involve an inventive step when the document is taken alone *Y* document of particular relevance; the claimed invention cannot be considered to involve an inventive step when the document is combined with one or more other such documents, such combination being obvious to a person skilled in the art. *&* document member of the same patent family			
Date of the actual completion of the international search <p style="text-align: center; font-size: 1.2em;">7 April 2006</p>		Date of mailing of the international search report <p style="text-align: center; font-size: 1.2em;">19/04/2006</p>		
Name and mailing address of the ISA/ European Patent Office, P.B. 5818 Patentlaan 2 NL - 2280 HV Rijswijk Tel. (+31-70) 340-2040, Tx. 31 651 epo nl, Fax: (+31-70) 340-3016		Authorized officer <p style="text-align: center; font-size: 1.2em;">PASCAL, A</p>		

INTERNATIONAL SEARCH REPORT

International application No

PCT/US2005/045282

C(Continuation). DOCUMENTS CONSIDERED TO BE RELEVANT

Category*	Citation of document, with indication, where appropriate, of the relevant passages	Relevant to claim No.
X	US 6 629 952 B1 (CHIEN THOMAS Y ET AL) 7 October 2003 (2003-10-07) the whole document	1-5, 9-12, 14, 15, 20-25, 29-32, 34, 35
X	US 5 429 597 A (DEMELLO ET AL) 4 July 1995 (1995-07-04) the whole document	1, 4, 5, 9-12, 14, 15
A	US 5 695 468 A (LAFONTAINE ET AL) 9 December 1997 (1997-12-09) column 5, line 33 - column 6, line 11; figures 3, 4 column 8, line 40 - column 10, line 47	1-40
A	US 2002/099405 A1 (YUREK MATTHEW T ET AL) 25 July 2002 (2002-07-25) the whole document	1-40
A	US 5 643 278 A (WIJAY ET AL) 1 July 1997 (1997-07-01) the whole document	1-40

INTERNATIONAL SEARCH REPORT

Information on patent family members

International application No PCT/US2005/045282

Patent document cited in search report	Publication date	Publication date	Patent family member(s)	Publication date
US 6548010	B1	15-04-2003	WO 0170323 A1	27-09-2001
US 2004010243	A1	15-01-2004	US 2004082879 A1	29-04-2004
US 6629952	B1	07-10-2003	NONE	
US 5429597	A	04-07-1995	CA 2184357 A1	08-09-1995
			EP 0743867 A1	27-11-1996
			WO 9523626 A1	08-09-1995
US 5695468	A	09-12-1997	DE 19533601 A1	21-03-1996
			FR 2724565 A1	22-03-1996
			JP 8173542 A	09-07-1996
			NL 1001217 C2	11-03-1997
			NL 1001217 A1	19-12-1995
			US 5545133 A	13-08-1996
			US 5647847 A	15-07-1997
			US 5728064 A	17-03-1998
US 2002099405	A1	25-07-2002	NONE	
US 5643278	A	01-07-1997	NONE	