

(No Model.)

A. BALDWIN.  
TENSION DEVICE FOR LOOM SHUTTLES.

No. 438,599.

Patented Oct. 21, 1890.

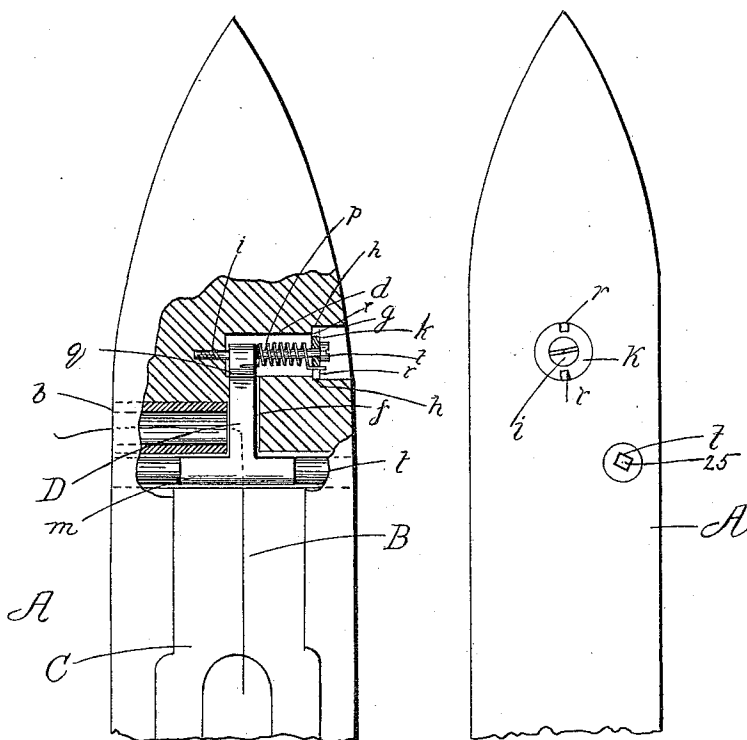

Fig. 1.

Fig. 2.

Witnesses.  
E. H. Fay.  
N. Dreyfus.

Inventor  
Alfred Baldwin,  
Per C. A. Shawlee,  
Attorneys.

# UNITED STATES PATENT OFFICE.

ALFRED BALDWIN, OF KENYON, RHODE ISLAND.

## TENSION DEVICE FOR LOOM-SHUTTLES.

SPECIFICATION forming part of Letters Patent No. 438,599, dated October 21, 1890.

Application filed February 27, 1890. Serial No. 341,958. (No model.)

*To all whom it may concern:*

Be it known that I, ALFRED BALDWIN, of Kenyon, in the county of Washington, State of Rhode Island, have invented certain new and useful Improvements in Tension Devices for Loom-Shuttles, of which the following is a description sufficiently full, clear, and exact to enable any person skilled in the art or science to which said invention appertains to make and use the same, reference being had to the accompanying drawings, forming part of this specification, in which—

Figure 1 is a plan view, partly in section, of a portion of a loom-shuttle provided with my improved tension mechanism; and Fig. 2, a side elevation of the same.

Like letters of reference indicate corresponding parts in the different figures of the drawings.

My invention relates to an adjustable tension for the filling-thread of loom-shuttles, and is designed as an improvement on the device shown in Letters Patent of the United States No. 418,670, granted to me for new and useful improvements in tension mechanism for loom-shuttles; and it consists in certain novel features hereinafter fully set forth and claimed, the object being to produce a cheaper and simpler device than is shown in said Letters Patent.

The nature and operation of the improvement will be readily understood by all conversant with such matters from the following explanation.

In the drawings, A represents the body of the shuttle, and B the filling-thread. A porcelain eye *b* opens into the bobbin-chamber C in the usual manner. A horizontally-arranged chamber *d* is formed in the toe of the shuttle parallel with the eye *b* and opens outward through the opposite side of said shuttle, the bottom of said chamber being preferably flush with the inner end of said eye. The chamber *d* is connected by a longitudinally-arranged opening or passage *f* with the bobbin-chamber C, said passage passing across the inner end of the shuttle-eye. The mouth of the chamber *d* is enlarged or countersunk at *g*, forming a shoulder *h* in the walls thereof. A screw *i* is turned centrally into the bottom of the chamber *d*, the body or shank of said screw being smooth. A nut

*k* is disposed on the screw and is fitted to enter the countersunk mouth of the chamber *d* and engage the shoulder *h*. A lever D has one end disposed loosely on the screw *i* and extends through the opening *f* into the bobbin-chamber, where it is provided with an elongated head *m*. A coiled spring *p* is wound around the screw *i* between the lever D and nut *k*, one end of said spring bearing against the upper face of said lever, as shown at *q*, and its opposite end being inserted in an opening *r* in the nut *k*. Said spring acts torsionally to depress said lever. The openings *r* in the nut are also fitted to receive the point of a tool, whereby said nut may be rotated or withdrawn from the mouth *g* of the chamber *d*. A tube or rod *t* passes laterally through the shuttle-body parallel with the shuttle-eye *b*, said tube or rod being exposed in the head of the bobbin-chamber in position to be engaged by the lever-head *m*. This tube or rod is preferably constructed of porcelain and forms a wear-plate for said lever.

In threading the shuttle the lever-head *m* is elevated and the thread inserted in the eye *b* in the usual manner. When the lever is released, its head *m* compresses the thread against the tube *t*, the spring *p* acting torsionally on said lever, as described. One end of the spring *p* being secured to the nut *k*, the tension of said spring on the lever D may be thereby regulated as desired. To hold the nut in position after being thus adjusted by means of the tool inserted in the openings *r* thereof, the screw *i* is turned inward into the shuttle-body, jamming said nut between the screw-head and the annular shoulder *h* of the chamber *d*. A constant tension is thus exerted upon the thread B by the lever *h m* and said thread prevented from passing too rapidly through the shuttle-eye.

The tube or rod may be fitted to rotate in the shuttle-body, so that when its surface in contact with the lever becomes worn a new surface may be readily presented. One end of the tube has a square opening or tool-socket 25 formed therein, as shown in Fig. 2, to receive a tool whereby said tube may be turned.

Having thus explained my invention, what I claim is—

The combination of a shuttle-body provided with a bobbin-chamber, a lateral thread-

eye, a lateral chamber adjacent to said thread-  
eye on the opposite side of said body, said  
chamber being enlarged at its outer end and  
having a shoulder at the inner end of the en-  
5 larged portion and an opening from the said  
lateral chamber to the bobbin-chamber, a nut  
resting directly on said shoulder within said  
lateral chamber, a screw passing through said  
nut and taking into the bottom of said lateral  
10 chamber, a thread-clamping lever pivoted on

said screw and extending into said bobbin-  
chamber, a torsional spring disposed on said  
screw and connected at one end to said nut  
and at the other end to said lever, and a wear-  
plate with which said lever acts for clamping 15  
the thread, substantially as described.

ALFRED BALDWIN.

Witnesses:

CHARLES S. WEAVER,  
JOSEPH E. LANPHEAR.