



- (51) International Patent Classification:
A61M 1/28 (2006.01)
- (21) International Application Number:
PCT/US2014/025450
- (22) International Filing Date:
13 March 2014 (13.03.2014)
- (25) Filing Language: English
- (26) Publication Language: English
- (30) Priority Data:
13/828,636 14 March 2013 (14.03.2013) US
- (71) Applicant: FRESENIUS MEDICAL CARE HOLDINGS, INC. [US/US]; 920 Winter Street, Waltham, MA 02451-1457 (US).
- (72) Inventors: UPDYKE, Palmer, David; c/o Fresenius USA Inc., 80 Empire Drive, Lake Forest, CA 92630 (US). FULKERSON, Barry; c/o Fresenius USA Inc., 80 Empire Drive, Lake Forest, CA 92630 (US). DE LEON DE LEON, Amaury; c/o Fresenius USA Inc., 80 Empire Drive, Lake Forest, CA 92630 (US). BAYLY, Michelle; c/o Fresenius USA Inc., 80 Empire Drive, Lake Forest, CA 92630 (US).

- (74) Agent: KILYK, Luke, A.; Kilyk & Bowersox, P.L.L.C., 400 Holiday Court, Suite 102, Warrenton, VA 20186 (US).
- (81) Designated States (unless otherwise indicated, for every kind of national protection available): AE, AG, AL, AM, AO, AT, AU, AZ, BA, BB, BG, BH, BN, BR, BW, BY, BZ, CA, CH, CL, CN, CO, CR, CU, CZ, DE, DK, DM, DO, DZ, EC, EE, EG, ES, FI, GB, GD, GE, GH, GM, GT, HN, HR, HU, ID, IL, IN, IR, IS, JP, KE, KG, KN, KP, KR, KZ, LA, LC, LK, LR, LS, LT, LU, LY, MA, MD, ME, MG, MK, MN, MW, MX, MY, MZ, NA, NG, NI, NO, NZ, OM, PA, PE, PG, PH, PL, PT, QA, RO, RS, RU, RW, SA, SC, SD, SE, SG, SK, SL, SM, ST, SV, SY, TH, TJ, TM, TN, TR, TT, TZ, UA, UG, US, UZ, VC, VN, ZA, ZM, ZW.
- (84) Designated States (unless otherwise indicated, for every kind of regional protection available): ARIPO (BW, GH, GM, KE, LR, LS, MW, MZ, NA, RW, SD, SL, SZ, TZ, UG, ZM, ZW), Eurasian (AM, AZ, BY, KG, KZ, RU, TJ, TM), European (AL, AT, BE, BG, CH, CY, CZ, DE, DK, EE, ES, FI, FR, GB, GR, HR, HU, IE, IS, IT, LT, LU, LV, MC, MK, MT, NL, NO, PL, PT, RO, RS, SE, SI, SK, SM, TR), OAPI (BF, BJ, CF, CG, CI, CM, GA, GN, GQ, GW, KM, ML, MR, NE, SN, TD, TG).

[Continued on next page]

(54) Title: UNIVERSAL PORTABLE ARTIFICIAL KIDNEY FOR HEMODIALYSIS AND PERITONEAL DIALYSIS

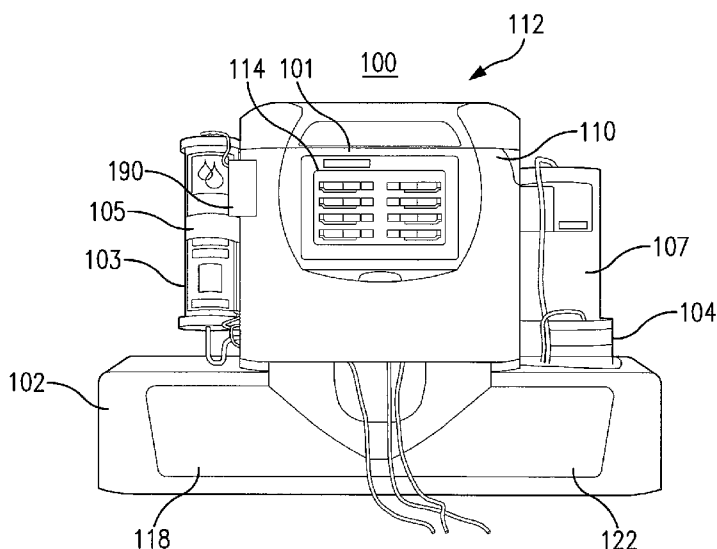

FIG. 1

(57) Abstract: Methods, systems, and kits are provided for performing hemodialysis, hemodiafiltration, and peritoneal dialysis on a portable machine suitable for both clinical and home use. Peritoneal dialysate can be flowed into and out of the peritoneal cavity, and can also be regenerated within the system, without the need for introducing fresh dialysate. Common hardware and software can be utilized for both peritoneal dialysis and other forms of dialysis such as hemodialysis, hemofiltration, and hemodiafiltration, allowing for facile transition between different dialysis modes using the same dialysis machine.





Published:

(88) Date of publication of the international search report:

- *with international search report (Art. 21(3))*
- *before the expiration of the time limit for amending the claims and to be republished in the event of receipt of amendments (Rule 48.2(h))*

16 April 2015

INTERNATIONAL SEARCH REPORT

International application No PCT/US2014/025450

A. CLASSIFICATION OF SUBJECT MATTER INV. A61M1/28 ADD.				
According to International Patent Classification (IPC) or to both national classification and IPC				
B. FIELDS SEARCHED				
Minimum documentation searched (classification system followed by classification symbols) A61M				
Documentation searched other than minimum documentation to the extent that such documents are included in the fields searched				
Electronic data base consulted during the international search (name of data base and, where practicable, search terms used) EPO-Internal, WPI Data				
C. DOCUMENTS CONSIDERED TO BE RELEVANT				
Category*	Citation of document, with indication, where appropriate, of the relevant passages	Relevant to claim No.		
X	US 2010/137782 A1 (JANSSON OLOF [SE] ET AL) 3 June 2010 (2010-06-03) paragraphs [0035], [0060]; figure 2 -----	19		
X	EP 0 498 382 A1 (PEABODY ALAN M [US]) 12 August 1992 (1992-08-12) paragraph [0034]; figure 1 -----	19		
X	US 2009/187138 A1 (LUNDTVEIT LOREN [US] ET AL) 23 July 2009 (2009-07-23) paragraphs [0043] - [0046]; figure 1 -----	19		
X	US 2011/160649 A1 (PAN LI [US]) 30 June 2011 (2011-06-30) paragraphs [0071], [0105]; figure 4 -----	19		
-/--				
<input checked="" type="checkbox"/> Further documents are listed in the continuation of Box C. <input checked="" type="checkbox"/> See patent family annex.				
* Special categories of cited documents : <table style="width: 100%; border: none;"> <tr> <td style="width: 50%; border: none; vertical-align: top;"> "A" document defining the general state of the art which is not considered to be of particular relevance "E" earlier application or patent but published on or after the international filing date "L" document which may throw doubts on priority claim(s) or which is cited to establish the publication date of another citation or other special reason (as specified) "O" document referring to an oral disclosure, use, exhibition or other means "P" document published prior to the international filing date but later than the priority date claimed </td> <td style="width: 50%; border: none; vertical-align: top;"> "T" later document published after the international filing date or priority date and not in conflict with the application but cited to understand the principle or theory underlying the invention "X" document of particular relevance; the claimed invention cannot be considered novel or cannot be considered to involve an inventive step when the document is taken alone "Y" document of particular relevance; the claimed invention cannot be considered to involve an inventive step when the document is combined with one or more other such documents, such combination being obvious to a person skilled in the art "&" document member of the same patent family </td> </tr> </table>			"A" document defining the general state of the art which is not considered to be of particular relevance "E" earlier application or patent but published on or after the international filing date "L" document which may throw doubts on priority claim(s) or which is cited to establish the publication date of another citation or other special reason (as specified) "O" document referring to an oral disclosure, use, exhibition or other means "P" document published prior to the international filing date but later than the priority date claimed	"T" later document published after the international filing date or priority date and not in conflict with the application but cited to understand the principle or theory underlying the invention "X" document of particular relevance; the claimed invention cannot be considered novel or cannot be considered to involve an inventive step when the document is taken alone "Y" document of particular relevance; the claimed invention cannot be considered to involve an inventive step when the document is combined with one or more other such documents, such combination being obvious to a person skilled in the art "&" document member of the same patent family
"A" document defining the general state of the art which is not considered to be of particular relevance "E" earlier application or patent but published on or after the international filing date "L" document which may throw doubts on priority claim(s) or which is cited to establish the publication date of another citation or other special reason (as specified) "O" document referring to an oral disclosure, use, exhibition or other means "P" document published prior to the international filing date but later than the priority date claimed	"T" later document published after the international filing date or priority date and not in conflict with the application but cited to understand the principle or theory underlying the invention "X" document of particular relevance; the claimed invention cannot be considered novel or cannot be considered to involve an inventive step when the document is taken alone "Y" document of particular relevance; the claimed invention cannot be considered to involve an inventive step when the document is combined with one or more other such documents, such combination being obvious to a person skilled in the art "&" document member of the same patent family			
Date of the actual completion of the international search	Date of mailing of the international search report			
28 January 2015	09/02/2015			
Name and mailing address of the ISA/ European Patent Office, P.B. 5818 Patentlaan 2 NL - 2280 HV Rijswijk Tel. (+31-70) 340-2040, Fax: (+31-70) 340-3016	Authorized officer Westsson, David			

INTERNATIONAL SEARCH REPORT

International application No PCT/US2014/025450

C(Continuation). DOCUMENTS CONSIDERED TO BE RELEVANT

Category*	Citation of document, with indication, where appropriate, of the relevant passages	Relevant to claim No.
X	EP 2 320 969 A1 (BAXTER INT [US]; BAXTER HEALTHCARE SA [CH]) 18 May 2011 (2011-05-18) paragraphs [0012], [0018] - [0019], [0042], [0051] - [0055]; figures 1,4 -----	37,56
A	US 3 707 967 A (KITRILAKIS S ET AL) 2 January 1973 (1973-01-02) abstract -----	37

INTERNATIONAL SEARCH REPORT

International application No.
PCT/US2014/025450

Box No. II Observations where certain claims were found unsearchable (Continuation of item 2 of first sheet)

This international search report has not been established in respect of certain claims under Article 17(2)(a) for the following reasons:

1. Claims Nos.: 1-18, 20-36, 38-55
because they relate to subject matter not required to be searched by this Authority, namely:
Claims 1-18, 20-36 and 38-55 refer to a method for treatment of the human or animal body by therapy and surgery, which is against Rule 39.1(iv) PCT and Rule 67.1(iv). The reason is that they include the step of flowing dialysate into a peritoneal cavity.
2. Claims Nos.:
because they relate to parts of the international application that do not comply with the prescribed requirements to such an extent that no meaningful international search can be carried out, specifically:
3. Claims Nos.:
because they are dependent claims and are not drafted in accordance with the second and third sentences of Rule 6.4(a).

Box No. III Observations where unity of invention is lacking (Continuation of item 3 of first sheet)

This International Searching Authority found multiple inventions in this international application, as follows:

see additional sheet

1. As all required additional search fees were timely paid by the applicant, this international search report covers all searchable claims.
2. As all searchable claims could be searched without effort justifying an additional fees, this Authority did not invite payment of additional fees.
3. As only some of the required additional search fees were timely paid by the applicant, this international search report covers only those claims for which fees were paid, specifically claims Nos.:
4. No required additional search fees were timely paid by the applicant. Consequently, this international search report is restricted to the invention first mentioned in the claims; it is covered by claims Nos.:

Remark on Protest

- The additional search fees were accompanied by the applicant's protest and, where applicable, the payment of a protest fee.
- The additional search fees were accompanied by the applicant's protest but the applicable protest fee was not paid within the time limit specified in the invitation.
- No protest accompanied the payment of additional search fees.

FURTHER INFORMATION CONTINUED FROM PCT/ISA/ 210

This International Searching Authority found multiple (groups of) inventions in this international application, as follows:

1. claim: 19

A peritoneal dialysis system configured to perform the method of performing peritoneal dialysis comprising: flowing dialysate along a first flow path through a manifold and into a dialysate reservoir;
weighing the dialysate in the dialysate reservoir to obtain a first weight;
flowing the dialysate out of the reservoir, along a second flow path through the manifold, and into a peritoneal cavity;
flowing the dialysate out of the peritoneal cavity, along a third flow path through the manifold, and into a drain reservoir;
weighing the dialysate in the drain reservoir to obtain a second weight; and
flowing the dialysate out of the drain reservoir and along a fourth flow path through the manifold;
the system comprising: the manifold; a dialysis machine in operable communication with the manifold and configured to flow the dialysate through the first, second, third, and fourth flow paths.
the dialysate reservoir in fluid communication with the manifold;
the drain reservoir in fluid communication with the manifold;
a scale configured to weigh at least one of the dialysate reservoir and the drain reservoir; and
a heater configured to heat dialysate in the dialysate reservoir.

2. claims: 37, 56

A peritoneal dialysis system configured to perform a method of performing peritoneal dialysis comprising:
flowing dialysate in a dialysate circuit through a first flow path, and into a dialysate reservoir, the first flow path comprising a flow path through a manifold and through a sorbent cartridge;
flowing the dialysate out of the dialysate reservoir and through the manifold along a second flow path that differs from the first flow path;
flowing the dialysate from the second flow path across at least one filter and into a peritoneum circuit;
flowing the dialysate through the peritoneum circuit and into a peritoneal cavity;
maintaining the dialysate in the peritoneal cavity;
flowing the dialysate out of the peritoneal cavity, through the peritoneum circuit, across the filter and back into the dialysate circuit; and
flowing the dialysate through the manifold along a third

FURTHER INFORMATION CONTINUED FROM PCT/ISA/ 210

flow path and back into the dialysate reservoir, the third flow path comprising a flow path through the sorbent cartridge; or
the method of performing peritoneal dialysis, comprising:
flowing a first dialysate in a peritoneum circuit along a first flow path, the first flow path comprising a flow path through a manifold;
flowing a second dialysate in a regeneration circuit along a second flow path and into a dialysate reservoir, the second flow path comprising a flow path through the manifold and through a sorbent cartridge;
flowing the second dialysate out of the dialysate reservoir along a third flow path through a first lumen of a dialyzer;
flowing the first dialysate through a second lumen of the dialyzer that is separated from the first lumen by at least one semipermeable membrane;
flowing the first dialysate into a peritoneal cavity;
maintaining the first dialysate in the peritoneal cavity, to form a dialysate; and
flowing the dialysate out of the peritoneal cavity;
the system comprising:
the manifold; a dialysis machine in operable communication with the manifold and configured to pump the first dialysate through the first flow path and configured to pump the second dialysate through the second and third flow paths;
the dialysate reservoir in fluid communication with the manifold;
the filter in fluid communication with the manifold;
the sorbent cartridge in fluid communication with the manifold;
a scale configured to weigh the dialysate reservoir; and
a heater configured to heat dialysate in the dialysate reservoir.

INTERNATIONAL SEARCH REPORT

Information on patent family members

International application No PCT/US2014/025450

Patent document cited in search report	A1	Publication date	Patent family member(s)	Publication date
US 2010137782	A1	03-06-2010	CN 1859936 A US 2010137782 A1	08-11-2006 03-06-2010

EP 0498382	A1	12-08-1992	AT 145142 T DE 69215123 D1 DE 69215123 T2 EP 0498382 A1 JP 2607798 Y2 JP H0576595 A JP 2002000012 U	15-11-1996 19-12-1996 05-06-1997 12-08-1992 08-07-2002 30-03-1993 10-05-2002

US 2009187138	A1	23-07-2009	AR 070195 A1 EP 2244763 A2 EP 2724738 A1 US 2009187138 A1 US 2013345622 A1 WO 2009091706 A2	17-03-2010 03-11-2010 30-04-2014 23-07-2009 26-12-2013 23-07-2009

US 2011160649	A1	30-06-2011	CN 103153359 A EP 2515964 A2 EP 2759311 A1 US 2011160649 A1 US 2014088493 A1 WO 2011079083 A2	12-06-2013 31-10-2012 30-07-2014 30-06-2011 27-03-2014 30-06-2011

EP 2320969	A1	18-05-2011	CA 2733511 A1 CN 102131533 A EP 2320969 A1 ES 2394911 T3 JP 2012501216 A US 2010051552 A1 WO 2010024963 A1	04-03-2010 20-07-2011 18-05-2011 06-02-2013 19-01-2012 04-03-2010 04-03-2010

US 3707967	A	02-01-1973	DE 2149040 A1 GB 1307056 A JP S528635 B1 NL 7113434 A US 3707967 A	06-04-1972 14-02-1973 10-03-1977 05-04-1972 02-01-1973
