

J. A. KEES.
 FURNACE REGULATOR.
 APPLICATION FILED APR. 21, 1909.

945,785.

Patented Jan. 11, 1910.

Fig. 1.

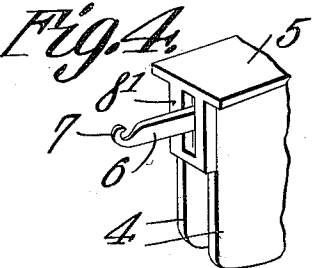
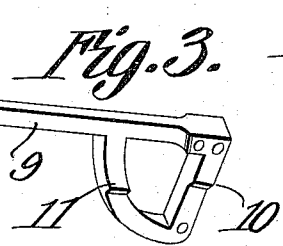
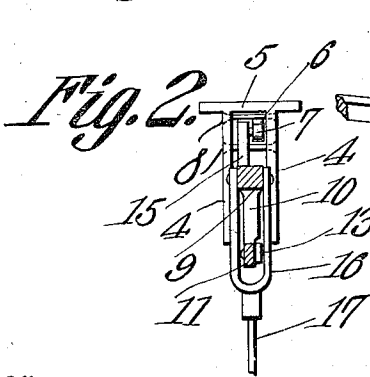
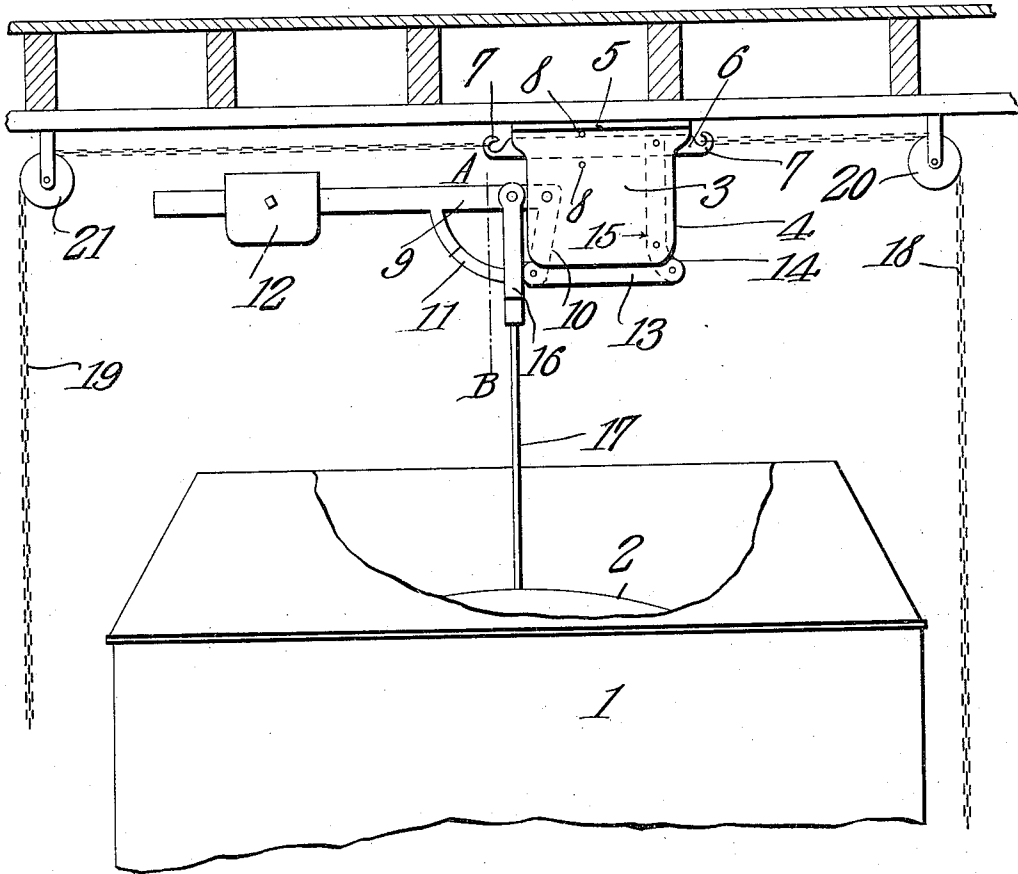

Witnesses

E. J. Stewart
F. J. Chapman.

Inventor

John A. Kees.

By *C. Snow & Co.*
 Attorneys

UNITED STATES PATENT OFFICE.

JOHN A. KEES, OF BEATRICE, NEBRASKA.

FURNACE-REGULATOR.

945,785.

Specification of Letters Patent. Patented Jan. 11, 1910.

Application filed April 21, 1909. Serial No. 491,217.

To all whom it may concern:

Be it known that I, JOHN A. KEES, a citizen of the United States, residing at Beatrice, in the county of Gage and State of Nebraska, have invented a new and useful Furnace-Regulator, of which the following is a specification.

This invention has reference to improvements in furnace regulators and is designed to provide a regulator for the draft openings of a furnace which regulator may be readily set to cause the furnace to produce any desired degree of heat within its capacity and maintain such heat at practically a constant point.

The present invention is an improvement upon the regulator shown and described in United States Letters Patent No. 870,028, granted to W. L. Hager, for improvement in furnace regulators, on November 5, 1907.

The object of the present invention is to provide a furnace regulator working upon substantially the principles of the regulator set forth in the said Letters Patent but which is of much simpler construction and is more readily installed.

The invention will best be understood from a consideration of the following detailed description taken in connection with the accompanying drawings forming a part of this specification, in which drawings—

Figure 1 is an elevation with parts broken away of the upper end of the furnace, and the improved regulator applied thereto. Fig. 2 is an end view of the regulator with a portion thereof shown in section on the line A—B of Fig. 1. Fig. 3 is a perspective view of a portion of the counterbalance lever. Fig. 4 is a perspective view of one end of the regulator casing showing a slightly modified construction.

Referring to the drawings, there is shown a furnace 1 and a portion of the dome 2 thereof. This showing of the furnace is not intended to be more than illustrative and may be taken as indicative of any furnace, especially of the hot-air type, wherein the dome 2 is liable to expansion and contraction under differences in the heat generated.

The regulator comprises a casing 3 which may be made of stamped steel and includes two side members 4 in parallel spaced relation and a top member 5 which may overhang the side members for facilitating the securing of the casing to the ceiling of the

room or compartment wherein the furnace 1 is located. Lodged within the upper portion of the casing is a sliding bar 6, longer than the length of the casing so that the ends project beyond the ends of the side members 4 and is there formed into hooks 7, there being a hook 7 at each end of the bar 6. This bar may be guided between two spaced pins 8 or the ends of the top plate 5 may be turned down as indicated at 8' in Fig. 4 and there slotted for the passage of the bar 6, the walls of the slots serving to guide the bar.

Pivotally secured to the side walls 4 of the casing near one end thereof is an angle lever 9 having a shorter arm 10 connected to the longer arm of the lever by means of a brace member 11, although of course this brace member 11 may be replaced by a strengthened web.

Beyond the brace member 11 the long arm of the lever carries an adjustable weight 12. The shorter arm 10 is connected by a link 13 at the lower end of the casing 3 with the short end 14 of another lever 15, pivotally mounted near the lower portion of the wings 4 at the end thereof remote from the point of pivot of the lever 9. The lever 15 extends upward between the wings 4 and is pivotally connected to the bar 6.

Connected to the long arm of the lever 9 near the pivot point thereof is a yoke 16 straddling the lever and the brace member 11 and this yoke carries a rod 17 extending down to the top of the furnace and into contact with the dome 2 of the furnace preferably at about the central point thereof.

One end of the bar 6 has attached thereto by means of the hook 7 a chain or flexible strand 18 and the other end of the bar has connected thereto by means of the corresponding hook 7 another flexible strand or chain 19, the chain 18 passing over a pulley 20 and the chain 19 over a pulley 21, which pulleys may depend from the ceiling of the room or compartment in which the structure is located.

The chains 18 and 19 lead from the draft door to the ash pit and the air valve to the smoke pipe of the furnace in the same manner as shown in the aforesaid Letters Patent.

Assuming that the parts are properly connected and adjusted, the draft door will be opened when the air valve in the smoke pipe is closed. When the furnace is cold the dome 2 is in the lowermost position. As

the heat in the furnace increases the dome 2 expands more and more and through the rod 17 and yoke 16 the expansion of the dome causes the lifting of the weighted end of the lever 9. This movement through the short end 10 of the lever 9 and the link 13 will cause the turning of the lever 15 on its pivot in a direction to move the bar 6 to the right as shown in Fig. 1 and this causes the closing of the ash pit door valve and the opening of the air valve in the smoke pipe. Of course the smoke pipe damper may be actuated instead of the air valve.

The relative movement of the air valve in the ash pit door and the air valve or damper in the smoke pipe will be regulated in accordance with requirements, and under some circumstances the draft door to the ash pit may be entirely closed before the air valve in the smoke pipe is opened at all, or these movements may overlap, or, in the case of the device acting on the damper of the smoke pipe the movements may be together. The action of the device is such that when the heat in the furnace increases to a certain predetermined extent then the expansion of the dome 2 of the furnace will cause a movement of the bar 6 in the direction to close the draft valve in the ash pit and thus throttle or entirely cut off the admission of air below the fire, thus checking the fire and preventing an increase in the vigor of the fire. The expansion of the dome will also serve to either close the damper of the smoke pipe to an extent commensurate with the increase in the vigor of the fire or open an air valve in the smoke pipe thus serving in either case to modify the draft. When the fire dies down then the dome 2 will drop or contract and the air valve to the smoke pipe or the damper will be moved to a position causing an increase of draft while the draft door to the ash pit will also at the proper time be opened. By this means the fire is kept at a practically constant rate and the degree of heat desired may be predetermined by the adjustment of the flexible strands or chains 18 and 19, the weight 12 acting to counterbalance the draft and check valve.

50 What is claimed is:

1. A furnace regulator comprising a suit-

able casing, an angle lever mounted therein and having one end provided with a counter-weight, said lever being adapted to receive motion from the dome of the furnace, 55 a sliding bar carried by the casing and adapted to be connected at the respective ends to separate oppositely acting draft controlling means of the furnace and connections between the weighted lever and the 60 bar to cause the actuating of the latter by the movement of the said lever.

2. A furnace regulator comprising a suitable casing, an angle lever mounted therein and having one end provided with a counter-weight, said lever being adapted to receive motion from the dome of the furnace, a sliding bar carried by the casing and adapted to be connected at the respective ends to separate oppositely acting draft controlling means of the furnace, another lever 70 carried by the casing and having its longer end connected to the sliding bar, and a link connecting the shorter end of the last named lever with the shorter end of the angle lever. 75

3. A furnace regulator comprising a suitable casing composed of two parallel side plates and a top plate, a sliding bar between the side plates and adjacent to the top plate and having each end formed into a hook for receiving connections extending respectively to separate oppositely acting draft controlling means of the furnace, a lever mounted between the side members of the casing near one end thereof, and having the longer end 85 connected to the sliding bar, an angle lever mounted between the side members of the casing near the other end thereof, a link connection between the shorter ends of the two levers, an adjustable weight carried by the 90 longer arm of the angle lever and a bar pivotally connected to the longer end of the angle lever near the pivot thereof and adapted to engage the dome of the furnace.

In testimony that I claim the foregoing as 95 my own, I have hereto affixed my signature in the presence of two witnesses.

JOHN A. KEES.

Witnesses:

G. H. FROLICK,
E. G. DRAKE.