

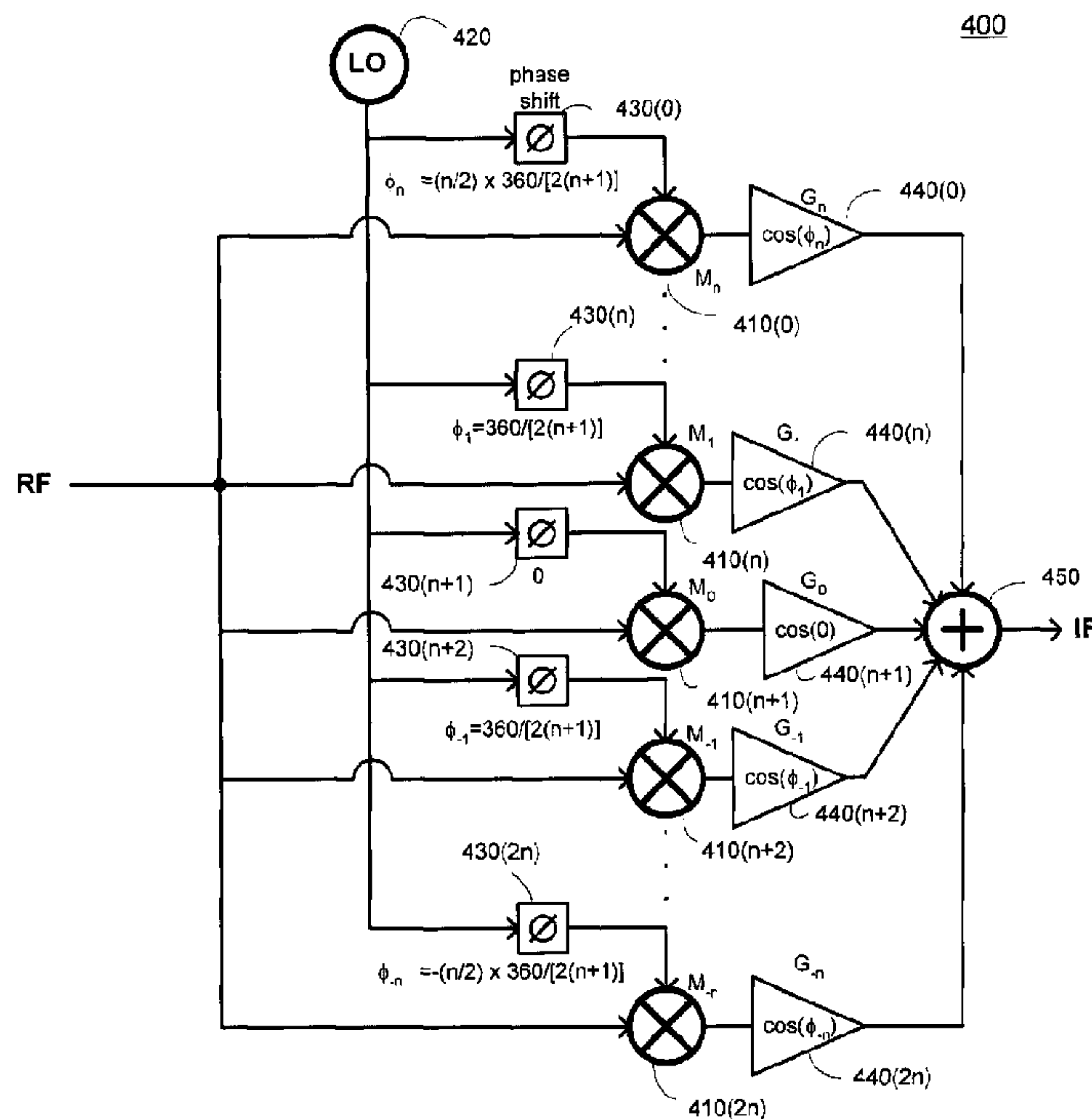

(86) Date de dépôt PCT/PCT Filing Date: 2005/12/12
 (87) Date publication PCT/PCT Publication Date: 2006/06/15
 (45) Date de délivrance/Issue Date: 2014/10/07
 (85) Entrée phase nationale/National Entry: 2007/05/25
 (86) N° demande PCT/PCT Application No.: US 2005/045099
 (87) N° publication PCT/PCT Publication No.: 2006/063358
 (30) Priorité/Priority: 2004/12/10 (US60/635,030)

(51) Cl.Int./Int.Cl. *H04B 1/10* (2006.01),
H03D 7/16 (2006.01)
 (72) Inventeurs/Inventors:
SEENDRIPU, KISHORE, US;
MONTEMAYOR, RAYMOND, US;
YE, SHENG, US;
CHANG, GLENN, US;
LING, CURTIS, US
 (73) Propriétaire/Owner:
MAXLINEAR INC., US
 (74) Agent: SMART & BIGGAR

(54) Titre : ARCHITECTURE DE RECEPTEURS A REJECTION D'HARMONIQUES ET MELANGEUR
 (54) Title: HARMONIC REJECT RECEIVER ARCHITECTURE AND MIXER



(57) Abrégé/Abstract:

Receiver architectures and methods of processing harmonic rich input signals employing harmonic suppression mixers are disclosed herein. The disclosed receivers, mixers, and methods enable a receiver to achieve the advantages of switching mixers while greatly reducing the mixer response to the undesired harmonics. A harmonic mixer can include a plurality of mixers coupled to an input signal. A plurality of phases of a local oscillator signal can be generated from a single local oscillator output. Each of the phases can be used to drive an input of one of the mixers. The mixer outputs can be combined to generate a frequency converted output that has harmonic rejection.

(12) INTERNATIONAL APPLICATION PUBLISHED UNDER THE PATENT COOPERATION TREATY (PCT)

(19) World Intellectual Property Organization
International Bureau(43) International Publication Date
15 June 2006 (15.06.2006)

PCT

(10) International Publication Number
WO 2006/063358 A1

(51) International Patent Classification:

H04B 1/10 (2006.01) H03D 7/16 (2006.01)

(21) International Application Number:

PCT/US2005/045099

(22) International Filing Date:

12 December 2005 (12.12.2005)

(25) Filing Language:

English

(26) Publication Language:

English

(30) Priority Data:

60/635,030 10 December 2004 (10.12.2004) US

(71) Applicant (for all designated States except US): **MAX-LINEAR INC.** [US/US]; 2036 Corte Del Nogal, #200, Carlsbad, California 92008 (US).

(72) Inventors; and

(75) Inventors/Applicants (for US only): **SEENDRIPU, Kishore** [IN/US]; 7174 Pintail Drive, Carlsbad, California 92009 (US). **MONTEMAYOR, Raymond** [US/US]; 2340 Carol View Drive, #301, Cardiff By The Sea, California 92116 (US). **YE, Sheng** [CN/US]; 3991-g Miramar Street, La Jolla, California 92037 (US). **CHANG, Glenn** [US/US]; 30312 Anamonte, Laguna Niguel, California 92677 (US). **LING, Curtis** [US/US]; 3162 North Mountain View, San Diego, California 92116 (US).(74) Agents: **HOM, Raymond, B.** et al.; Townsend And Townsend And Crew LLP, 12730 High Bluff Drive, Suite 400, San Diego, California 92130 (US).

(81) Designated States (unless otherwise indicated, for every kind of national protection available): AE, AG, AL, AM, AT, AU, AZ, BA, BB, BG, BR, BW, BY, BZ, CA, CH, CN, CO, CR, CU, CZ, DE, DK, DM, DZ, EC, EE, EG, ES, FI, GB, GD, GE, GH, GM, HR, HU, ID, IL, IN, IS, JP, KE, KG, KM, KN, KP, KR, KZ, LC, LK, LR, LS, LT, LU, LV, LY, MA, MD, MG, MK, MN, MW, MX, MZ, NA, NG, NI, NO, NZ, OM, PG, PH, PL, PT, RO, RU, SC, SD, SE, SG, SK, SL, SM, SY, TJ, TM, TN, TR, TT, TZ, UA, UG, US, UZ, VC, VN, YU, ZA, ZM, ZW.

(84) Designated States (unless otherwise indicated, for every kind of regional protection available): ARIPO (BW, GH, GM, KE, LS, MW, MZ, NA, SD, SL, SZ, TZ, UG, ZM, ZW), Eurasian (AM, AZ, BY, KG, KZ, MD, RU, TJ, TM), European (AT, BE, BG, CH, CY, CZ, DE, DK, EE, ES, FI, FR, GB, GR, HU, IE, IS, IT, LT, LU, LV, MC, NL, PL, PT, RO, SE, SI, SK, TR), OAPI (BF, BJ, CF, CG, CI, CM, GA, GN, GQ, GW, ML, MR, NE, SN, TD, TG).

Published:

— with international search report

[Continued on next page]

(54) Title: HARMONIC REJECT RECEIVER ARCHITECTURE AND MIXER

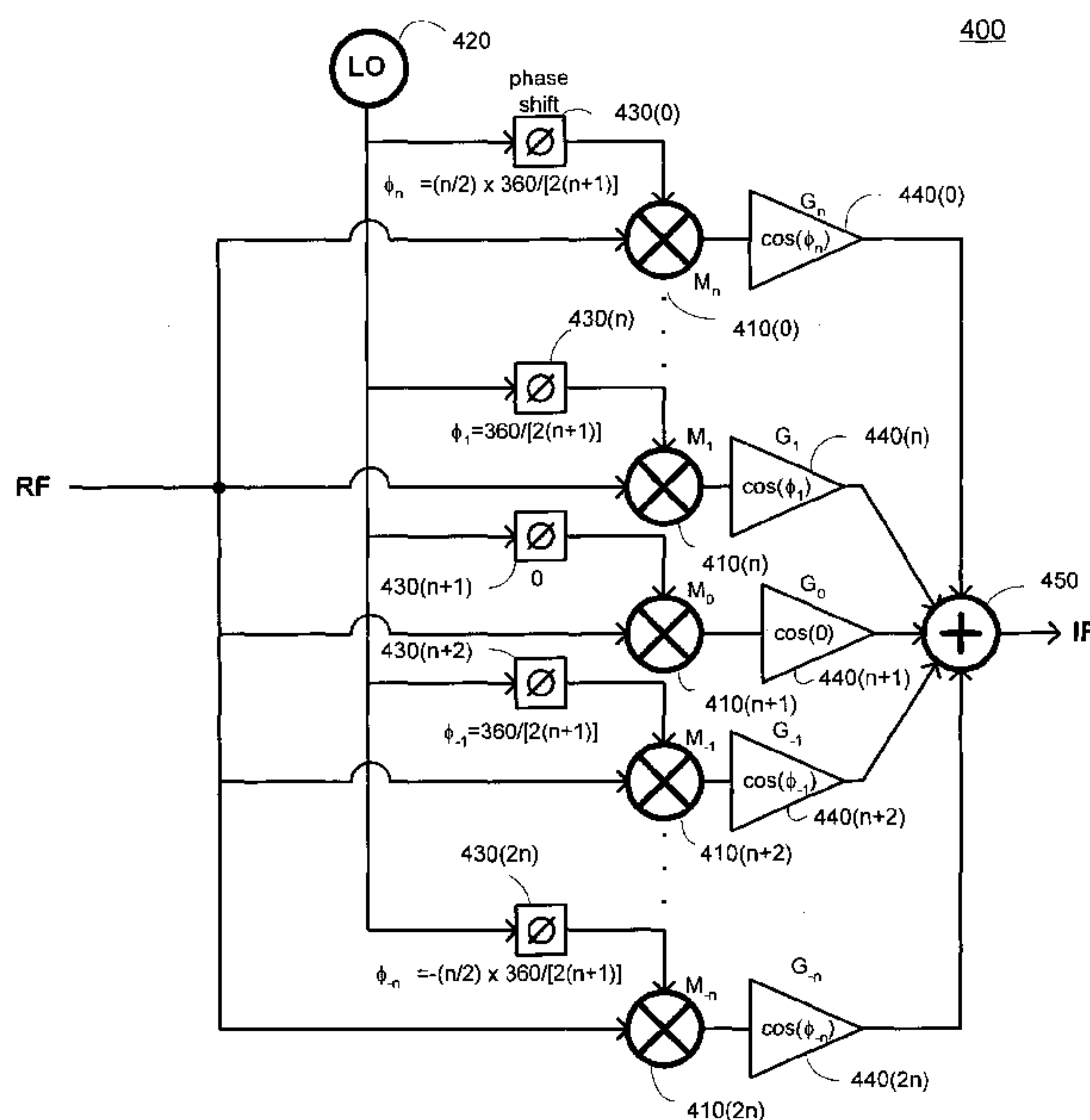

(57) Abstract: Receiver architectures and methods of processing harmonic rich input signals employing harmonic suppression mixers are disclosed herein. The disclosed receivers, mixers, and methods enable a receiver to achieve the advantages of switching mixers while greatly reducing the mixer response to the undesired harmonics. A harmonic mixer can include a plurality of mixers coupled to an input signal. A plurality of phases of a local oscillator signal can be generated from a single local oscillator output. Each of the phases can be used to drive an input of one of the mixers. The mixer outputs can be combined to generate a frequency converted output that has harmonic rejection.

WO 2006/063358 A1

WO 2006/063358 A1



— *before the expiration of the time limit for amending the claims and to be republished in the event of receipt of amendments*

For two-letter codes and other abbreviations, refer to the "Guidance Notes on Codes and Abbreviations" appearing at the beginning of each regular issue of the PCT Gazette.

HARMONIC REJECT RECEIVER ARCHITECTURE AND MIXER

[0001]

BACKGROUND

[0002] The disclosure relates to electronic signal processing. More particularly, the disclosure relates to a harmonic reject RF receiver, harmonic reject receiver architecture, and harmonic reject mixers.

[0003] RF communication systems often provide numerous frequency division multiplexed channels distributed over a predetermined operating band. A receiver can typically be configured to tune to a desired channel to receive the information provided on that channel.

[0004] In many communication systems, the operating band is a relatively narrow band. That is, the operating band typically does not occupy greater than an octave. However, in some communication systems, such as television, the operating frequency band may include hundreds of channels occupying several octaves.

[0005] Such a wide operating bandwidth can present particular problems not experienced in other systems having sub-octave operating frequency bands. For example, a wide operating bandwidth may include multiple in band interferers. The undesired channels in a television operating band can appear as interferers to the desired channel. The undesired channels can be at substantially the same power level, or even at a greater power level, than the power level of the desired channel.

[0006] A receiver typically filters or otherwise attenuates undesired channels and other interference sources. However, some interferers may contribute to in band interference due to operation of the receiver, such that filtering is ineffective. In particular, a receiver may unintentionally frequency convert the harmonics of the desired input signal to the same frequency band that is converts the desired signal.

[0007] Because the interferer can frequency convert to an in band interference signal, it is not possible to filter out the interference. Additionally, the input operating frequency band may span multiple octaves and may include the harmonics. The receiver may not be able to sufficiently eliminate the effects of the harmonic interferers by filtering the input signal.

5

BRIEF SUMMARY

[0008] Receiver architectures and methods of processing harmonic rich input signals employing harmonic suppression mixers are disclosed herein. The disclosed receivers, mixers, and methods enable a receiver to achieve the advantages of switching mixers while greatly reducing the mixer response to the undesired harmonics. A harmonic mixer can include a plurality of mixers coupled to an input signal. A plurality of phases of a local oscillator signal can be generated from a single local oscillator output. Each of the phases can be used to drive an input of one of the mixers. The mixer outputs can be combined to generate a frequency converted output that has harmonic rejection.

10

15

[0009] In accordance with one aspect of the invention there is provided a harmonic reject mixer. The mixer includes a plurality of mixers, each mixer having an input coupled to a common RF input, and a phase shifter having an input coupled to a common LO input and a having plurality of phase shifted outputs. The common LO input signal includes a plurality of transitions during each period of a phase shifted output, the phase shifter being operable to generate the plurality of phase shifted outputs based on the plurality of transitions, each distinct transition in the plurality of transitions corresponding to a phase shifted output in the plurality of phase shifted outputs. Each of the phase shifted outputs is coupled to a LO input on a corresponding mixer. The mixer also includes a combiner having a plurality of inputs, each input coupled to an output from an associated mixer, and configured to provide a combined output.

20

25

[0010] Each of the plurality of mixers may include a switching mixer.

[0011] Each of the plurality of mixers may include a CMOS switching mixer.

[0012] The phase shifter may include a plurality of distinct phase shifters, each configured to provide a distinct predetermined phase shift.

30

[0012a] The phase shifter may be configured to generate a plurality of phase shifted outputs equally spaced about the span of -90 to +90 degrees.

[0012b] The plurality of mixers may include three distinct mixers, and the plurality of phase shifted outputs may include outputs shifted by -45, 0, and +45 degrees.

[0012c] The mixer may include a plurality of amplifiers, each of the plurality of amplifiers coupled to a distinct one of the plurality of mixers and configured to amplify a mixer output
5 by a gain based at least in part on an LO phase shift.

[0012d] In accordance with another aspect of the invention there is provided a method of harmonic rejection mixing. The method involves generating a plurality of phases of a LO signal based on a control signal. The control signal includes a plurality of transitions during each period of the LO signal, and each transition in the plurality of transitions corresponds to
10 one of the plurality of phases of the LO signal. The method also involves mixing an input signal with each of the plurality of phases of the LO signal to generate a plurality of mixed output signals, and combining the plurality of mixed output signals to provide a mixer output.

[0012e] Mixing the input signal may involve coupling the input signal to a plurality of switching mixers, and driving each of the plurality of switching mixers with a distinct one of
15 the plurality of phase of the LO signal.

[0012f] Generating the plurality of phases of the LO signal may involve phase shifting the LO signal using a plurality of distinct phase shifters, each of the plurality of distinct phase shifters providing a distinct phase shift.

[0012g] Generating the plurality of phases of the LO signal may involve generating an odd
20 number of distinct phases of the LO signal equally spaced about a span of -90 to +90 degrees.

[0012h] Combining the plurality of mixed output signals may involve summing the plurality of mixed output signals.

[0012i] The method may involve amplifying each of the plurality of mixed output signals by a gain based on an LO phase shift.

[0012j] The input signal may include an RF signal in a multi-octave operating band.
25

[0012k] The input signal may include a television signal.

[0012l] In accordance with another aspect of the invention there is provided a quadrature mixer. The mixer includes a plurality of harmonic reject mixers, each harmonic reject mixer having an input coupled to a common RF input signal, and each harmonic reject mixer having
30 an input coupled to a different phase shifted LO signal in a plurality of phase shifted LO signals. Each phase shifted LO signal in the plurality of phase shifted LO signals is generated

according to a respective transition in a plurality of transitions of a control signal, and the control signal includes a plurality of transitions during each period of the LO signal. The mixer also includes a first combiner having inputs coupled to outputs from a first subset of the plurality of harmonic reject mixers, and an output configured to provide a quadrature output.

5 The mixer further includes a second combiner having inputs coupled to outputs from a second subset of the plurality of harmonic reject mixers, and an output configured to provide an in-phase output.

[0012m] Each of the plurality of harmonic reject mixers may include one or more switching mixers, each switching mixer having an input coupled to a common RF input.

10 **[0012n]** The may include a polyphase filter having an input and a plurality of outputs, each of the plurality of outputs configured to provide the plurality of phases of the input signal.

[0012o] In accordance with another aspect of the invention there is provided a method of quadrature mixing. The method involves generating a plurality of phases shifted LO signals according to a control signal including a plurality of transitions during each period of an LO signal, each phase shifted LO signal in the plurality of phase shifted LO signals corresponding to a respective transition in the plurality of transitions of the control signal. The method also involves mixing an input signal with a phase shifted LO signal from the plurality of phase shifted LO signals to generate a plurality of mixer outputs, combining a first subset of mixer outputs to generate a quadrature mixer output, and combining a second subset of mixer outputs to generate an in-phase mixer output.

20 **[0012p]** In accordance with another aspect of the invention there is provided a receiver. The receiver includes a filter having an input coupled to an RF input, and a filtered output. The receiver also includes a harmonic reject down converter having an input coupled to the filtered output and a Local Oscillator (LO) input configured to receive an LO control signal.

25 The LO control signal includes a plurality of transitions during each period of a phase shifted LO signal, the harmonic reject down converter generates a plurality of phase shifted LO signals according to the plurality of transitions of the control signal.

[0012q] The filter may include a programmable bandwidth filter.

[0012r] The harmonic reject down converter may include a plurality of switching mixers, each switching mixer having an input coupled to a common RF input and one of the plurality of phase shifted LO signals, and a combiner having a plurality of inputs, each input coupled to

an output from one of the plurality of switching mixers, and configured to provide a combined output.

[0012s] The RF input signal may include a television signal.

5 BRIEF DESCRIPTION OF THE DRAWINGS

[0013] The features, objects, and advantages of embodiments of the disclosure will become more apparent from the detailed description set forth below when taken in conjunction with the drawings, in which like elements bear like reference numerals.

10 [0014] Figure 1 is a simplified functional block diagram of an embodiment of a receiver in a system.

[0015] Figure 2 is simplified functional block diagram of an embodiment of a receiver.

[0016] Figure 3 is a simplified functional block diagram of an embodiment of a receiver front end.

15 [0017] Figure 4 is a simplified functional block diagram of an embodiment of a harmonic reject mixer.

[0018] Figure 5 is a simplified functional block diagram of an embodiment of a harmonic reject mixer.

[0019] Figure 6 is a simplified functional block diagram of a downconverter having harmonic reject mixers.

20 DETAILED DESCRIPTION OF EMBODIMENTS OF THE INVENTION

[0020] This disclosure describes harmonic reject mixers and receiver architectures which utilize harmonic reject mixers to permit an efficient implementation of a direct downconversion or low-IF receiver. The current approach to receiver design may employ switching mixers within the receiver front end. This permits the system to achieve low noise and high linearity. However, these switching mixers also efficiently downconvert input signals at undesired harmonic multiples of the local oscillator frequency to the desired output frequency band. The frequency conversion of undesired signals poses a problem which is

particularly important for television applications where the desired input range is so wide that the likelihood of undesired harmonics is high. Receiver architectures and methods of processing harmonic rich input signals employing harmonic suppression mixers are disclosed herein. The disclosed receivers, mixers, and methods enable a receiver to achieve the advantages of switching mixers while greatly reducing the mixer response to the undesired harmonics.

[0021] Figure 1 is a simplified functional block diagram of an embodiment of a receiver 100 implementing harmonic reject signal processing in a system 10. The following description describes an embodiment in which the system 10 is configured to operate as a television receiver. However, the system 10 can be any of a plurality of systems. For example, the system 10 can be a television, television receiver, set top box, or television tuner integrated within a video recorder or some other television receiver. In other embodiments, the system 10 can be a radio receiver, wireless transceiver, telephone receiver, cellular telephone, cordless telephone, or some other communication device.

[0022] The system 10 can include a source switch 12 that can be coupled to one or more signal sources. For example, a first source input can be coupled to an antenna 2 and a second source input can be coupled to a wired source, such as a cable coupled to a cable television distributor. The source switch 12 is not limited to coupling only one type of signal to the receiver 100. For example, the source switch 12 can be coupled to a television signal source, for example, via the antenna 2, and can be coupled to a radio source, for example, via the cable 4.

[0023] The source switch 12 can be configured to couple any one of the signals from any signal source to the input of the receiver 100. The receiver 100 can be, for example, configured to selectively process television signals received from a signal source, such as analog television signals formatted according to an analog television standard, such as NTSC, PAL, SECAM, or some other analog television standard. The receiver 100 can also be configured to process digital television signals, such as digital DVB-T television signals, received from one of the signal sources.

[0024] The receiver 100 can receive the RF signal from the source switch 12 and can downconvert the signal to an output IF. The output IF from the receiver 100 can be coupled to a demodulator 50 and from the demodulator 50 to a baseband processor 60. In one embodiment, the demodulator 50 can be configured to demodulate a television signal at a

predetermined IF. The demodulated television signals are communicated to a baseband processor 60 that can be configured, for example, to format the signals into video and audio signals for corresponding video and audio output devices (not shown).

5 [0025] The system 10 can also include a mode selection module 20 that can be configured to receive a mode selection input from an external source (not shown) that can be, for example, a user selection or user control. The mode can correspond to an operating mode of the receiver 100, and can be used to determine a particular operating band, channel spacing, channel bandwidths, and output IF frequency.

10 [0026] The mode select module 20 can be coupled to a channel select module 30. The channel select module 30 can be coupled to the mode select module 20 and can be configured to generate the desired local oscillator (LO) control signals. The channel select module 30 can generate the control signals needed to tune the LO frequencies of the receiver 100 to enable reception of the desired RF signal and generation of the desired output IF. The channel select module 30 can also receive one or more input signals from an external source
15 (not shown), such as a user interface or some other module or device that can indicate a desired channel selection.

[0027] The channel select module 30 can independently control the RF and IF LOs within the receiver 100. For example, the channel select module 30 can tune the RF LO to a frequency that is based on both a mode and a desired channel. The channel select module 30
20 can also be configured to control the frequency of the IF LO and may be configured to control the IF LO based only on the desired mode. In other embodiments, the channel select module 30 can be configured to tune both the RF and LO frequencies for each channel.

[0028] The channel select module 30 can also be configured to control calibration of the receiver 100. The calibration can include DC offset calibration and In-phase (I) and
25 Quadrature (Q) signal balancing. For example, the channel select module 30 can control an RF switch within the receiver 100 and can initiate the DC offset calibration. In another embodiment, a calibration module within the receiver 100 can receive the channel select signals and the filter control signals and can initiate DC offset calibration, including
30 controlling the RF switch and filter bandwidths during the duration of the DC offset calibration.

[0029] A filter controller 40 can also be coupled to the mode select module 20. The filter controller 40 can be configured to provide the control signals to the receiver 100 that control

one or more filter bandwidths within the receiver 100. The filter controller 40 can be configured to set the filter bandwidths based on the channel selectivity required in the receiver 100, which can depend on the operating mode.

5 [0030] The filter controller 40 can also be in communication with the channel select module 30. The filter controller 40 can be configured to control the filters within the receiver 100 to predetermined bandwidths for a predetermined calibration duration following each channel change. For example, the filter controller 40 can be configured to tune the filters to a minimal bandwidth during DC offset calibration. Alternatively, a calibration module within the receiver 100 can be configured to control the filter bandwidths during the calibration
10 duration.

[0031] A processor 72 and associated memory 74 can be included within the system 10 and can be configured to perform one or more functions within each of the modules. For example, the memory 74 can include one or more processor 72 usable instructions in the form of software that can, when executed by the processor 72, perform some or all of the functions
15 of the various modules within the system 10.

[0032] Figure 2 is a simplified functional block diagram of an embodiment of a receiver 100 that can be implemented on one or more substrates of one or more integrated circuits (ICs). In some embodiments, it may be advantageous to integrate the entire receiver on a single IC. In other embodiments, it may be advantageous to integrate a portion of the
20 receiver 100 in a first IC or on a first substrate and integrate the remainder of the receiver 100 on a second IC or second substrate. The first and second substrates can be implemented in a single package or may be implemented in distinct packages. For example, a signal path within the receiver 100 can be implemented on a first substrate and one or more local oscillators can be implemented on a second substrate and couple to the first substrate through
25 one or more interconnects.

[0033] Although the signal interconnections shown in Figure 2 appear as single ended signal interconnects, it is generally understood that some or all of the interconnections can be implemented as differential connections. It may be advantageous to implement differential interconnections, for example, for the purposes of noise reduction.

30 [0034] Portions of the receiver 100 can be implemented digitally, and can be configured to operate on digital representations of the signal. The digital processing of the signals within the receiver 100, and embodiments of receivers 100 having digital portions, are not explicitly

illustrated in the receiver 100 to allow the description to focus on the functionality of the various blocks and modules.

[0035] The receiver 100 can be configured to provide significant harmonic rejection.

When the receiver 100 is configured to process signals over a wide input signal band, such as
5 in a television receiver application, the input frequency band may span multiple octaves. As
such, the input frequency band may have potentially numerous signals at harmonics of the
desired input signal. One or more of the signals at the harmonics of the desired input signal
may have substantial signal strength and may even be stronger than the desired input signal.

[0036] The signals at the harmonics of the desired input signal can appear as interferers.

10 Certain harmonic frequencies can be particularly troublesome interferers because signals at
these harmonic frequencies can frequency convert to the same frequencies as the desired
input signal. The receiver architectures and harmonic reject mixers disclosed herein can be
used to substantially reduce the effects of input signals at harmonics of the desired input
signal.

15 **[0037]** The receiver 100 can include an RF amplifier 102 that is configured to receive a
signal at the input to the receiver 100 and amplify it. The RF amplifier 102 can be configured
to receive a signal, for example, from an interconnect to an antenna or wired connection, such
as a single ended wireline, a differential wireline, a twisted pair, a coaxial cable, a
transmission line, a waveguide, an optical receiver configured to receive an optical signal
20 over an optical fiber, and the like, or some other signal medium.

[0038] The RF amplifier 102 can be configured in any of several different embodiments or
combination of embodiments, depending on the application. In one embodiment, the RF
amplifier 102 can be a Low Noise Amplifier (LNA). In another embodiment, the RF
amplifier 102 can be a variable gain amplifier, and the gain of the RF amplifier can be
25 selected by one or more control lines (not shown) to the receiver 100. In the embodiment
where the RF amplifier 102 is a variable gain amplifier, the gain of the RF amplifier 102 can
be part of a gain control loop, such as an automatic gain control (AGC) loop (not shown).
The RF amplifier 102 can be configured as a single amplifier stage or can include multiple
amplifier stages. Where multiple amplifier stages are used, the amplifier stages can include
30 serial, parallel, or a combination of serial and parallel amplifier configurations.

[0039] The output of the RF amplifier 102 can be coupled to a filter 104 that can be
configured as a programmable harmonic rejection filter. The filter 104 can be configured, for

example, as a programmable bandwidth lowpass filter, having a cutoff frequency that can be programmed to reduce undesired harmonic frequency components. As described below, the use of a harmonic reject frequency conversion stage can substantially reduce the constraints on the filter 104.

5 [0040] The output of the filter 104 can be coupled to inputs of first and second frequency conversion modules, here shown as a first mixer 112 and a second mixer 114. The first and second mixers 112 and 114 are shown as mixers, but can be any type of frequency conversion device exhibiting harmonic rejection. For example, the first and second mixers 112 and 114 can be double balanced mixers, double-quadrature mixers, interferometers, or some other
10 type of frequency conversion device configured to reject the harmonics of an input signal.

[0041] The first and second mixers 112 and 114 can be configured to generate in-phase (I) and quadrature (Q) frequency converted signal components. The first mixer 112 is described as part of the in-phase signal path and the second mixer 114 is described as part of the quadrature signal path for purposes of discussion.

15 [0042] An RF LO 120 can be configured to generate a local oscillator signal to frequency convert the received RF signal to a baseband signal or a low Intermediate Frequency (IF) signal. As used herein, the term baseband signal refers to baseband signals as well as to signals that are substantially baseband signals. A signal is substantially a baseband signal if the frequency conversion process to downconvert a signal is imperfect, for example, due to
20 LO offset errors or differences at the transmitter or receiver and errors or differences in the RF signal relative to a specified frequency of operation. For example, an RF signal may be different from a specified operating channel due to LO frequency shifts at the transmitter or Doppler shifts. Typically, the error or difference is a fraction of the baseband signal bandwidth.

25 [0043] A low IF signal can refer to an IF frequency that is less than twice the baseband signal bandwidth. However, in other embodiments, low IF can refer to less than 1.5, 2.5, 3, 4, 5, 10, or some other multiple of the baseband signal bandwidth. Typically, a low IF signal refers to a signal that is at a frequency sufficiently low to allow processing of the signal without additional frequency conversions.

30 [0044] The receiver 100 can be configured to operate using direct conversion to baseband in some operating modes while converting to a low IF in other operating modes. For example, the receiver 100 can operate in low-IF mode for analog TV applications, and

substantially zero-IF for digital applications. Using distinct frequency conversion modes for separate operating modes may be advantageous because the receiver 100 architecture can be optimized for signal characteristics.

5 [0045] Analog television standards such as NTSC or PAL require less channel selection and image rejection in its low-pass filtering, but are much more sensitive to DC offset which typically are present in a zero-IF implementation. This makes an analog television receiver 100 more suited for a low-IF implementation, which may suffer from poorer channel selectivity, but which also substantially eliminates the DC offset problems associated with zero-IF.

10 [0046] Digital TV (e.g. DVB-T) requires greater channel selection, but is less sensitive to DC offset that may be introduced by a zero-IF architecture. This makes digital TV well-suited for a zero-IF approach, which offers better channel selectivity and no image rejection limitations, but may introduce some DC offset to the signal.

15 [0047] The frequency of the RF LO 120 can be programmable, and the frequency can be programmed based in part on the frequency of the desired signal. In a direct conversion frequency conversion, the output of the RF LO 120 can be substantially equal to the center frequency of a double side band input signal. In other embodiments, the RF LO 120 can be tuned to a frequency that is a multiple of the desired input frequency, and the frequency divided to the desired LO frequency.

20 [0048] The output of the RF LO 120 can be coupled to a first phase shifter 122 that can be configured to generate at least two distinct versions of a LO signal that are substantially in quadrature. Because inaccuracies in the quadrature LO signals can contribute to undesired signal components in the recovered signal, it is desirable to generate accurate quadrature LO signals. In one embodiment, the first phase shifter 122 can include a phase shifted signal path and a direct signal path, where the phase shifted signal path results in a signal that is 25 substantially 90 degrees shifted relative to the signal from the direct signal path. In another embodiment, the first phase shifter 122 can include a polyphase filter that is configured to generate the two LO signals in quadrature.

30 [0049] The in-phase LO signal can be coupled to an in-phase LO buffer amplifier 116 that amplifies the in-phase LO signal and couples it to a LO input port of the first mixer 112. Similarly, the quadrature LO signal can be coupled to a quadrature LO buffer amplifier 118 that amplifies the quadrature LO signal and couples it to a LO port of the second mixer 114.

[0050] The output of the first mixer 112 can be an in-phase baseband signal that is coupled to an in-phase filter 132. The in-phase filter 132 can be programmable filter whose bandwidth can be selected based on one or more control signals (not shown) provided to the receiver 100. The bandwidth of the in-phase filter 132 can be selected, for example, based on
5 a communication standard or mode that the receiver 100 is configured to support. Therefore, where the receiver 100 is configured to support multiple standards having different channel bandwidths, the bandwidth of the in-phase filter 132 can be selected based in part on the presently supported mode.

[0051] When the signal is a baseband signal or a low IF signal, the in-phase filter 132 can
10 be configured as a low pass filter. Alternatively, the in-phase filter 132 can be configured as a bandpass filter if the low IF signal has sufficient bandwidth to make the use of a low pass filter undesirable.

[0052] The output of the in-phase filter 132 can be coupled to a third mixer 152 configured to frequency convert the in-phase signal to a desired output IF. In one embodiment, the
15 output of the in-phase filter 132 is a baseband signal and the third mixer is configured to upconvert the in-phase baseband signal to an output IF.

[0053] The third mixer 152 can be driven by a programmable LO that is generated in much the same manner that is used to generate the LO for the first and second mixers 112 and 114. The IF LO 140 can be programmable to allow the output IF to be selected based in part on
20 the mode supported by the receiver 100. For example, the receiver 100 can be configured to frequency convert the input signals to a predetermined IF that can depend on the manner in which the user configures the system having the receiver 100. For example, a set top box for television signals can be configured to generate an output signal at a predetermined IF, such as 70 MHz, or at a frequency corresponding to a television channel.

[0054] The output of the IF LO 140 can be coupled to a second phase shifter 142 that is
25 configured to generate substantially quadrature LO signals.. An in-phase LO output from the second phase shifter 142 can be coupled to an in-phase buffer amplifier 156 that amplifies the in-phase LO signal and couples it to the LO input of the third mixer 152. The output of the third mixer 152 is an in-phase IF signal that is coupled to a first input of a signal combiner
30 160.

[0055] The quadrature signal path is configured to be substantially identical to the in-phase signal path. The two signal paths are typically substantially matched to reduce undesirable signal components that can be generated due to I and Q mismatches.

5 [0056] The output of the second mixer 114 can be a baseband quadrature signal that is coupled to an input of a quadrature filter 134. The quadrature filter 134 can be configured as a programmable low pass filter having programmable bandwidth. Typically, the configuration and bandwidths of the in-phase and quadrature filters 132 and 134 are the same such that the in-phase and quadrature signal paths remain substantially matched.

10 [0057] The output of the quadrature filter 134 can be coupled to an input of a fourth mixer 154 that is configured to upconvert the quadrature signal to the output IF. The fourth mixer 154 is driven by an LO signal that is generated by the IF LO 140. The output of the IF LO 140 is coupled to a second phase shifter 142 that generates a quadrature LO signal. The quadrature LO signal is coupled to a quadrature buffer amplifier 158 which amplifies the quadrature LO signal and couples it to an LO input of the fourth mixer 154. The output of
15 the fourth mixer 154 can be a quadrature IF signal. The quadrature IF signal can be coupled to a second input of the signal combiner 160.

[0058] The signal combiner 160 can be configured to combine the in-phase and quadrature IF signals. The signal combiner 160 can be, for example, a signal summer that sums the in-phase IF signal with the quadrature IF signal. In one embodiment, the signal combiner 160
20 sums the two signals while maintaining their phases. In another embodiment, the signal combiner 160 can invert one of the phases and sum the two signals. In yet another embodiment, the signal combiner 160 can generate the sum of the two signals and can invert the output signal.

[0059] The output of the signal combiner 160 represents the output IF signal. The output
25 IF signal can be coupled to an output filter 170 that can be, for example, a low pass filter or bandpass filter that is configured to remove undesired signal products from the IF output signal. The output filter 170 can be configured as a fixed bandwidth filter or can be configured as a programmable bandwidth filter, where the bandwidth is determine, in part, based on a mode of the receiver 100.

30 [0060] The output of the output filter 170 can be coupled to an IF amplifier 172 that can be configured to amplify the output. The IF amplifier 172 can be a variable gain amplifier. The

gain of the IF amplifier 172 can be controlled using one or more control inputs (not shown) on the receiver 100. The output of the IF amplifier 172 can be the output of the receiver 100.

[0061] It may be advantageous to implement the entire receiver 100 on a single integrated circuit, such that the processes and conditions used to manufacture the in-phase and quadrature signal components are closely matched, resulting in more closely matched I and Q signal paths. Additionally, it may be advantageous to implement the components on a single IC to minimize path length distances or variations that contribute to mismatches. A single IC implementation can also result in a smaller receiver 100 package.

[0062] Figure 3 is a simplified functional block diagram of a harmonic reject receiver front end 300 configured to downconvert a desired signal to baseband or IF while substantially attenuating signals generated by the harmonics of the desired input signal. The receiver front end 300 can be used, for example, in the receiver embodiments shown in Figures 1 and 2.

[0063] The receiver front end 300 is configured to receive input signals via an antenna 301. Although the receiver front end 300 is described as receiving signals via an antenna 310, the receiver front end 300 can be configured to omit the antenna 310 and can receive signals via a wired link (not shown).

[0064] The output of the antenna 301 is coupled to an RF amplifier 102, such as a LNA. The RF amplifier 102 can be configured to amplify substantially the entire input frequency band. A receiver front end 300 configured to support processing of television signals may need to support an input frequency band spanning multiple octaves.

[0065] The output of the RF amplifier 102 is coupled to a programmable harmonic reject filter 140, which can be configured as a programmable bandwidth low pass filter. The cutoff frequency of the programmable harmonic reject filter 140 can be controlled to a frequency that is based at least in part on the frequency of the desired input signal. In some embodiments, the cutoff frequency is programmable over a wide frequency range that spans multiple octaves.

[0066] Harmonic rejection is typically achieved by applying large amounts of filtering prior to mixing. In RF applications where the signal band is narrow compared with the carrier frequency of the desired input signal, harmonic rejection is a natural byproduct of front-end filtering from band-select filters or the antenna 301. In a broadband application, harmonic interferers constitute a significant problem, and harmonic rejection low-pass filtering needs to

be programmable to allow the receiver to receive channels across the entire band while achieving the desired harmonic suppression. The implementation of the programmable harmonic reject filter 140 incurs a power and area penalty. Additionally, rejecting input harmonics with solely a programmable harmonic reject filter 140 may have limited effectiveness, and can also results in signal path losses and associated noise degradation in performance.

[0067] The embodiment of the receiver front end 300 illustrated in Figure 3 uses a harmonic rejection downconverter 310 to further suppress the response to higher harmonics of the desired fundamental. The harmonic reject downconverter 310 can relax the filter requirements imposed on the programmable harmonic reject filter 140, or can improve the harmonic reject performance by providing harmonic suppression in addition to that provided by the programmable harmonic reject filter 140. The harmonic rejection downconverter 310 is illustrated as a double quadrature mixer implementing harmonic reject mixers. The particular embodiment of the harmonic rejection downconverter 310 is described in further detail in association with Figure 6.

[0068] In the embodiment of the receiver front end 300 shown in Figure 3, the output of the programmable harmonic reject filter 140 is coupled to an input of the harmonic rejection downconverter 310. The harmonic reject downconverter 310 is configured to generate quadrature output signals. The output signals can be at baseband, a low IF, or an IF, depending on the frequencies of the desired input signal and the LO (not shown).

[0069] An in-phase filter 132 can be configured to filter the in-phase signal component and a quadrature filter 134 can be configured to filter the quadrature signal component. The outputs of the filters 132 and 134 can be coupled to additional stages for further processing, such as those shown in Figure 2.

[0070] Figure 4 is a simplified functional block diagram of an embodiment of a harmonic reject mixer 400. The harmonic reject mixer 400 can be used, for example, in the receiver of Figure 2 or the receiver front end of Figure 3 to provide rejection of undesired harmonics of the input signal.

[0071] The harmonic reject mixer 400 includes $(2n+1)$ switching mixers 410(0) - 410(2n). The RF input signal is coupled to an input of each of the switching mixers 410(0) - 410(2n). Each of the switching mixers 410(0) - 410(2n) is driven by a phase offset version of a Local Oscillator (LO) 420 output signal. The number of switching mixers 410(0) - 410(2n) should

be greater than one to achieve harmonic rejection. Each of the switching mixers 410(0) - 410(2n) can be, for example, a CMOS switching mixer.

[0072] The output from the LO 420 is coupled to (2n+1) phase shifters 430(0) - 430(2n). The phase shifters can be distinct phase shifters or distinct phase outputs of one or more
5 phase shifters having multiple outputs. Each of the phase shifters 430(0) - 430(2n) is configured to shift the phase of the LO 420 signal by a predetermined discrete phase. The LO 420 signal, phase shifted in discrete steps ($\phi_n - \phi_{-n}$), is used to drive the LO inputs of the switching mixers 410(0) - 410(2n).

[0073] In one embodiment, the phase shifters 430(0) - 430(2n) provide (2n+1) versions of
10 the LO signal equally spaced about a half cycle. For example, the phase shifters can be configured to provide LO phases equally spaced in the interval of -90 - +90 degrees. That is, each of the phase shifters 430(0) - 430(2n) can be configured to provide a discrete phase shift (in degrees) determined by the formula

$$\phi_n = (n/2) \times 360/[2(n+1)].$$

[0074] Each of the outputs from the switching mixers 410(0) - 410(2n) is coupled to a
15 corresponding amplifier 440(0) - 440(2n). The switching mixer output signals are scaled by their respective gains $G_n - G_{-n}$. In one embodiment, each of gains is configured to equalize the signal gain through each of the switching mixer amplifier paths. In another embodiment, all of the gains are substantially the same. In still another embodiment, each of the individual
20 gains can be set to a distinct value determined based on the phase shift provided by the corresponding phase shifter. For example, the gain of each amplifier can be based on $\cos(\phi_j)$.

[0075] The outputs of the amplifiers 440(0) - 440(2n) are coupled to a combiner 450, here shown as a signal summer. The combiner 450 combines the amplified switching mixer outputs into a single frequency converted output signal.

[0076] The harmonic rejection arises from the fact that the mixer 400 approximates a linear
25 mixer (ideal multiplication by a sinusoid) using shifted and scaled versions of the mixed RF signal. The LO 420 control the transitions of the various switching mixers 440(0) - 440(2n) based on the phase shifts. In one embodiment, there are (2n+1) switching mixer transitions in each LO period. For the case of n=0, the harmonic reject mixer is substantially identical to
30 the response of a single switching mixer.

[0077] The harmonic mixer 400 includes a plurality of switching mixers, each driven by a distinct phase of an LO signal. This accomplishes the dual purpose of permitting low-noise switching mixer designs driven by relatively simple LO circuits, while achieving high harmonic rejection across a wide range of harmonics.

5 [0078] Figure 5 is a simplified functional block diagram of an embodiment of a harmonic reject mixer 500 using three distinct phases. Thus, the embodiment of Figure 5 corresponds to the generalized harmonic reject mixer of Figure 4 with $n=1$.

[0079] Thus, the RF input signal is coupled to three switching mixers 410(0) -410(2). An output of a LO 420 is coupled to three distinct phase shifters 430(0) - 430(2). Using the
10 formula provided above, the three phase shifters 430(0)-430(2) provide phase shifts of +45, 0, and -45 degrees. The switching mixer 410(0) -410(2) outputs are coupled to corresponding amplifiers 440(0)-440(2). The corresponding amplifier gains are scaled by $(1/\sqrt{2})$, 1, and $(1/\sqrt{2})$, respectively. The outputs of the three amplifiers 440(0)-440(2) are coupled to an input of a signal summer 450 where they are summed to an output IF or baseband signal.

15 [0080] Figure 6 is a simplified functional block diagram of a downconverter 600 having harmonic reject mixers 620, 630, 640, and 650. Each of the harmonic mixers 620, 630, 640, and 650, can be configured as shown in Figures 4 or 5.

[0081] The downconverter 600 of Figure 6 is implemented as a double balanced quadrature mixer. The double balanced quadrature mixer configuration shown in Figure 6 provides
20 additional harmonic rejection of the 5th and 9th harmonics. The additional harmonic rejection provided by the double balanced quadrature configuration permits the use of more simple harmonic reject mixers 620, 630, 640, and 650 in the core. This may be advantageous from a standpoint of fabrication, area, gate count, complexity, or cost.

[0082] In the downconverter 600 configured as a double balanced quadrature mixer, an
25 input RF signal is coupled to a polyphase filter 610. The polyphase filter 610 generates multiple phase outputs from the input signal. In the embodiment shown in Figure 6, the polyphase filter 610 is configured to generate in-phase and quadrature signal outputs.

[0083] The quadrature signal outputs are coupled to first and second harmonic mixers 620 and 630. The in-phase signal outputs are coupled to third and fourth harmonic mixers 640
30 and 650.

[0084] The second and third harmonic mixers, 630 and 640, are driven with an in-phase LO signal. The first and fourth harmonic mixers, 620 and 650, are driven with a quadrature LO signal. The outputs of the first and third harmonic mixers, 620 and 640, are combined to generate the quadrature downconverted signal, while the outputs of the second and third
5 harmonic mixers 630 and 650 are combined to generate the in-phase downconverted signal.

[0085] Harmonic mixers, receivers using harmonic mixers, and methods of processing input signals to reduce the contribution of input harmonics have been described. A harmonic mixer can include a plurality of switching mixers, each driven with a distinct phase of a common LO. The outputs of the switching mixers can be combined or otherwise summed to a
10 single output signal. The output signal exhibits reduced contribution from input harmonics.

[0086] The steps of a method, process, or algorithm described in connection with the embodiments disclosed herein may be embodied directly in hardware, in a software module executed by a processor, or in a combination of the two. The various steps or acts in a method or process may be performed in the order shown, or may be performed in another order.

15 Additionally, one or more process or method steps may be omitted or one or more process or method steps may be added to the methods and processes. An additional step, block, or action may be added in the beginning, end, or intervening existing elements of the methods and processes.

[0087] The above description of the disclosed embodiments is provided to enable any
20 person of ordinary skill in the art to make or use the disclosure. Various modifications to these embodiments will be readily apparent to those of ordinary skill in the art, and the generic principles defined herein may be applied to other embodiments without departing from the spirit or scope of the disclosure.

THE EMBODIMENTS OF THE INVENTION IN WHICH AN EXCLUSIVE PROPERTY OR PRIVILEGE IS CLAIMED ARE DEFINED AS FOLLOWS:

1. A harmonic reject mixer comprising:

5

a plurality of mixers, each mixer having an input coupled to a common RF input;

10

a phase shifter having an input coupled to a common LO input and a having plurality of phase shifted outputs, the common LO input signal comprising a plurality of transitions during each period of a phase shifted output, the phase shifter being operable to generate the plurality of phase shifted outputs based on the plurality of transitions, wherein each distinct transition in the plurality of transitions corresponds to a phase shifted output in the plurality of phase shifted outputs and each of the phase shifted outputs is coupled to a LO input on a corresponding mixer; and

15

a combiner having a plurality of inputs, each input coupled to an output from an associated mixer, and configured to provide a combined output.

20

2. The mixer of claim 1, wherein each of the plurality of mixers comprises a switching mixer.

25

3. The mixer of claim 1, wherein each of the plurality of mixers comprises a CMOS switching mixer.

4. The mixer of claim 1, wherein the phase shifter comprises a plurality of distinct phase shifters, each configured to provide a distinct predetermined phase shift.

30

5. The mixer of claim 1, wherein the phase shifter is configured to generate a plurality of phase shifted outputs equally spaced about the span of **-90** to **+90** degrees.

6. The mixer of claim 1, wherein:

the plurality of mixers comprise three distinct mixers; and the plurality of phase shifted outputs comprise outputs shifted by -45, 0, and +45 degrees.

5

7. The mixer of claim 1, further comprising a plurality of amplifiers, each of the plurality of amplifiers coupled to a distinct one of the plurality of mixers and configured to amplify a mixer output by a gain based at least in part on an LO phase shift.

10

8. A method of harmonic rejection mixing, the method comprising:

generating a plurality of phases of a LO signal based on a control signal, wherein the control signal comprises a plurality of transitions during each period of the LO signal, and wherein each transition in the plurality of transitions corresponds to one of the plurality of phases of the LO signal;

15

mixing an input signal with each of the plurality of phases of the LO signal to generate a plurality of mixed output signals; and

20

combining the plurality of mixed output signals to provide a mixer output.

9. The method of claim 8, wherein mixing the input signal comprises:

25

coupling the input signal to a plurality of switching mixers; and

driving each of the plurality of switching mixers with a distinct one of the plurality of phase of the LO signal.

10. The method of claim 8, wherein generating the plurality of phases of the LO signal comprises phase shifting the LO signal using a plurality of distinct phase shifters, each of the plurality of distinct phase shifters providing a distinct phase shift.
- 5 11. The method of claim 8, wherein generating the plurality of phases of the LO signal comprises generating an odd number of distinct phases of the LO signal equally spaced about a span of -90 to +90 degrees.
12. The method of claim 8, wherein combining the plurality of mixed output signals comprises summing the plurality of mixed output signals.
- 10 13. The method of claim 8, further comprising amplifying each of the plurality of mixed output signals by a gain based on an LO phase shift.
14. The method of claim 8, wherein the input signal comprises an RF signal in a multi-
15 octave operating band.
15. The method of claim 8, wherein the input signal comprises a television signal.
16. A quadrature mixer comprising:
- 20 a plurality of harmonic reject mixers, each harmonic reject mixer having an input coupled to a common RF input signal, and each harmonic reject mixer having an input coupled to a different phase shifted LO signal in a plurality of phase shifted LO signals, wherein each phase shifted LO signal in the
25 plurality of phase shifted LO signals is generated according to a respective transition in a plurality of transitions of a control signal, and wherein the control signal comprises a plurality of transitions during each period of the LO signal;

a first combiner having inputs coupled to outputs from a first subset of the plurality of harmonic reject mixers, and an output configured to provide a quadrature output; and

5 a second combiner having inputs coupled to outputs from a second subset of the plurality of harmonic reject mixers, and an output configured to provide an in-phase output.

10 17. The quadrature mixer of claim 16, wherein each of the plurality of harmonic reject mixers comprises:

one or more switching mixers, each switching mixer having an input coupled to a common RF input.

15 18. The quadrature mixer of claim 16, further comprising a polyphase filter having an input and a plurality of outputs, each of the plurality of outputs configured to provide the plurality of phases of the input signal.

20 19. A method of quadrature mixing, the method comprising:

generating a plurality of phases shifted LO signals according to a control signal comprising a plurality of transitions during each period of an LO signal, wherein each phase shifted LO signal in the plurality of phase shifted LO signals corresponds to a respective transition in the plurality of transitions of the control signal;

25

mixing an input signal with a phase shifted LO signal from the plurality of phase shifted LO signals to generate a plurality of mixer outputs;

30 combining a first subset of mixer outputs to generate a quadrature mixer output; and

combining a second subset of mixer outputs to generate an in-phase mixer output.

5 **20.** A receiver comprising:

a filter having an input coupled to an RF input, and a filtered output; and

10 a harmonic reject down converter having an input coupled to the filtered output and a Local Oscillator (LO) input configured to receive an LO control signal, the LO control signal comprising a plurality of transitions during each period of a phase shifted LO signal, wherein the harmonic reject down converter generates a plurality of phase shifted LO signals according to the plurality of transitions of the control signal.

15 **21.** The receiver of claim **20**, wherein the filter comprises a programmable bandwidth filter.

20 **22.** The receiver of claim **20**, wherein the harmonic reject down converter comprises:

a plurality of switching mixers, each switching mixer having an input coupled to a common RF input and one of the plurality of phase shifted LO signals; and

25 a combiner having a plurality of inputs, each input coupled to an output from one of the plurality of switching mixers, and configured to provide a combined output.

23. The receiver of claim **20**, wherein the RF input signal comprises a television signal.

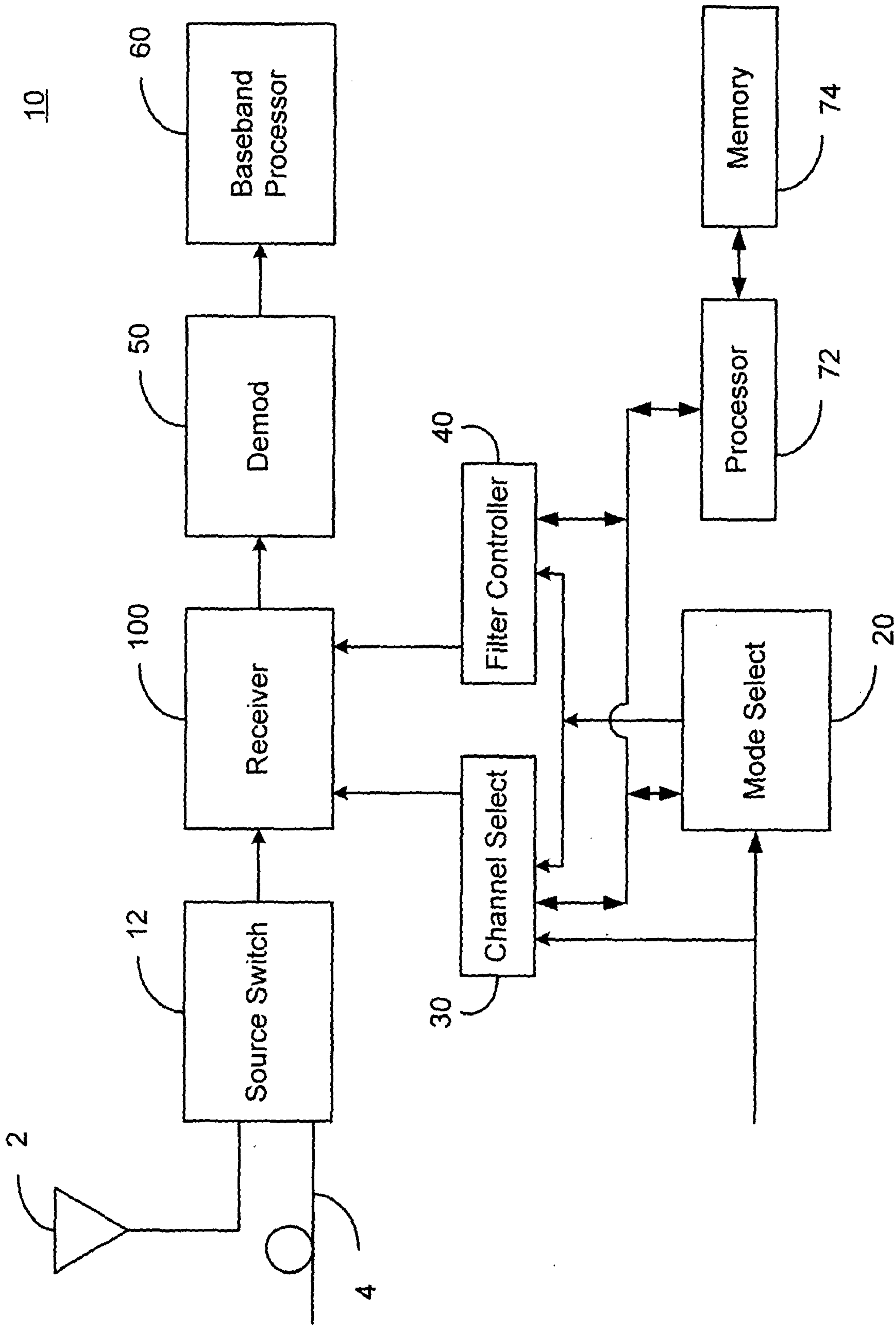

FIG. 1

100

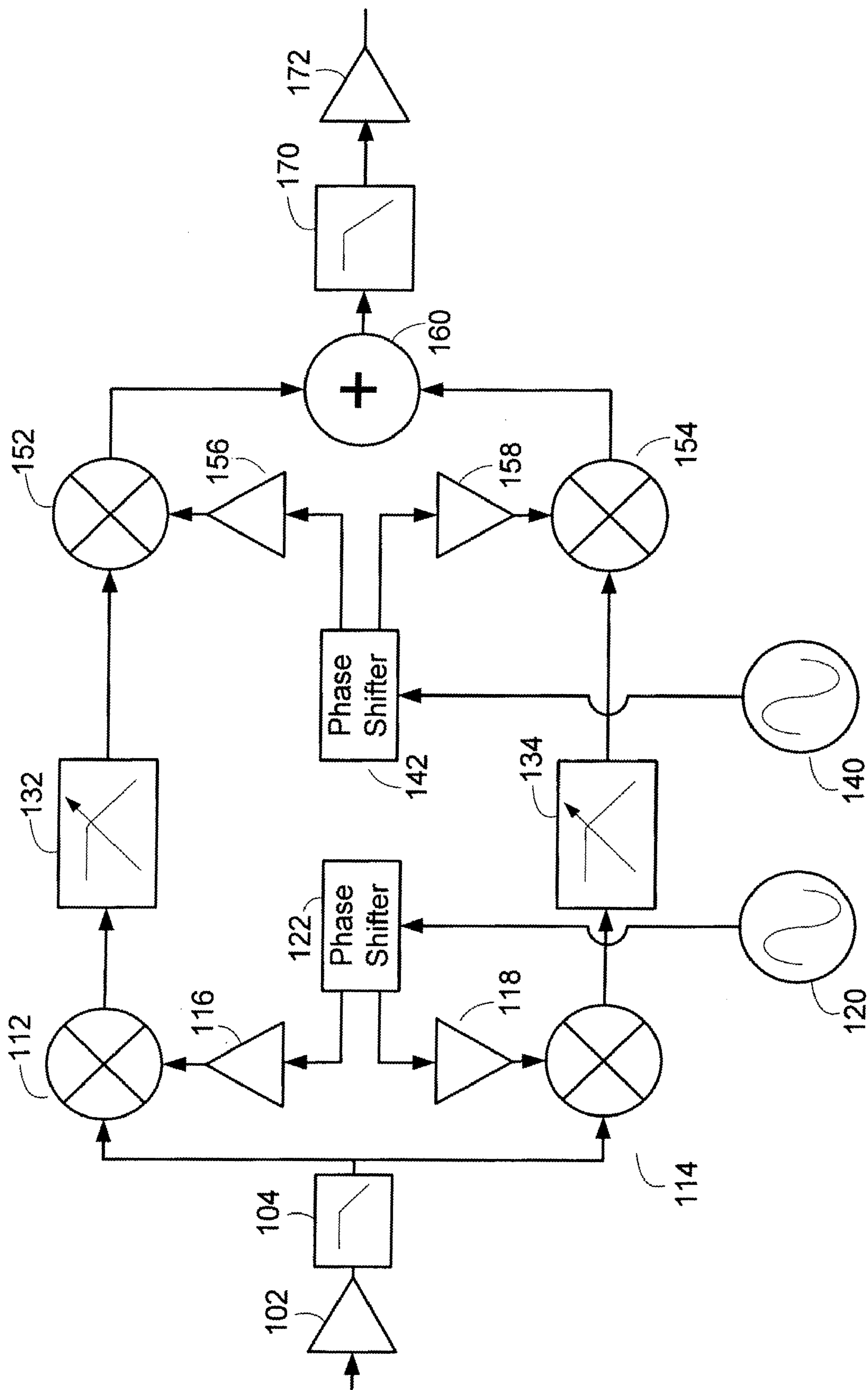

FIG. 2

300

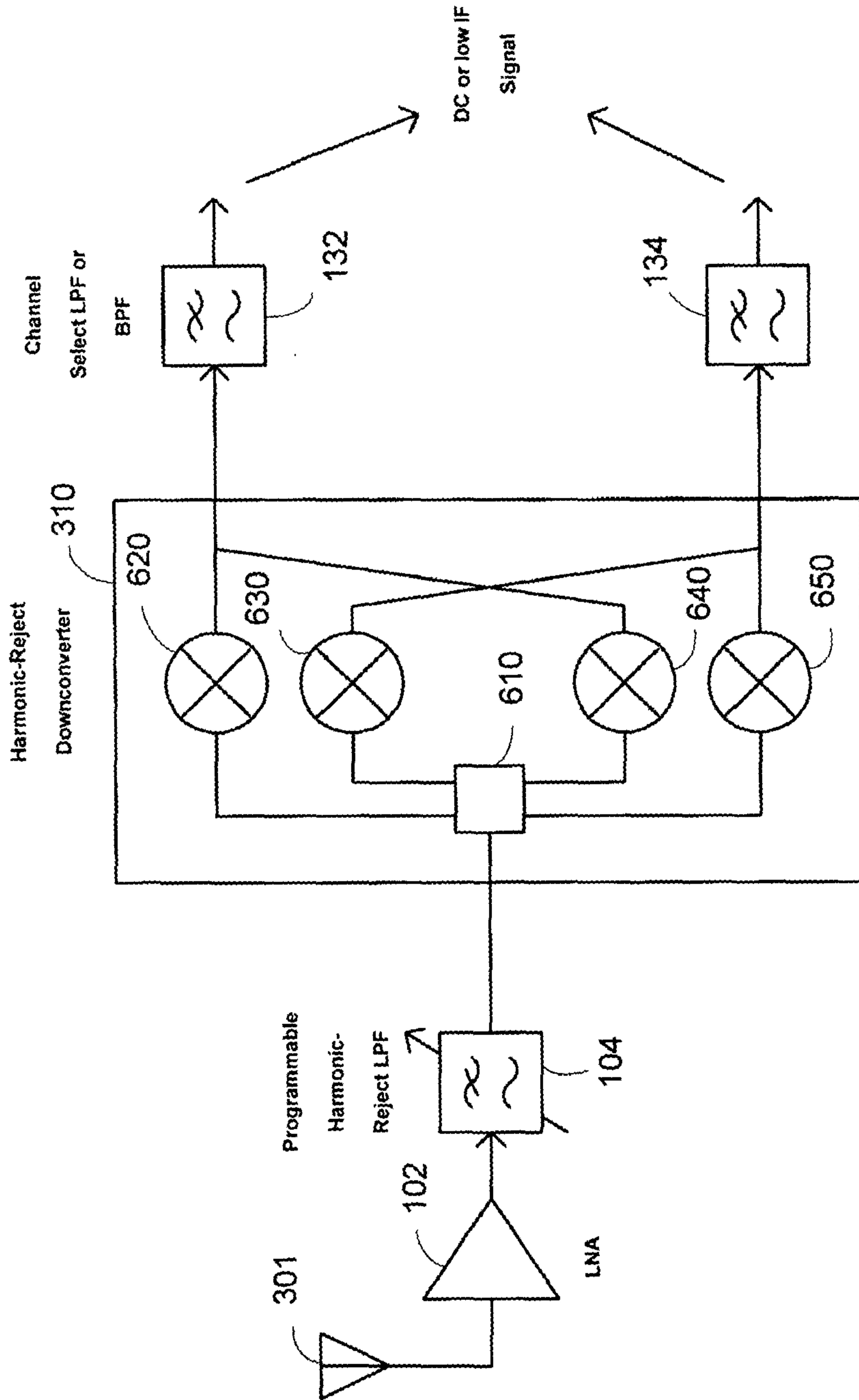

FIG. 3

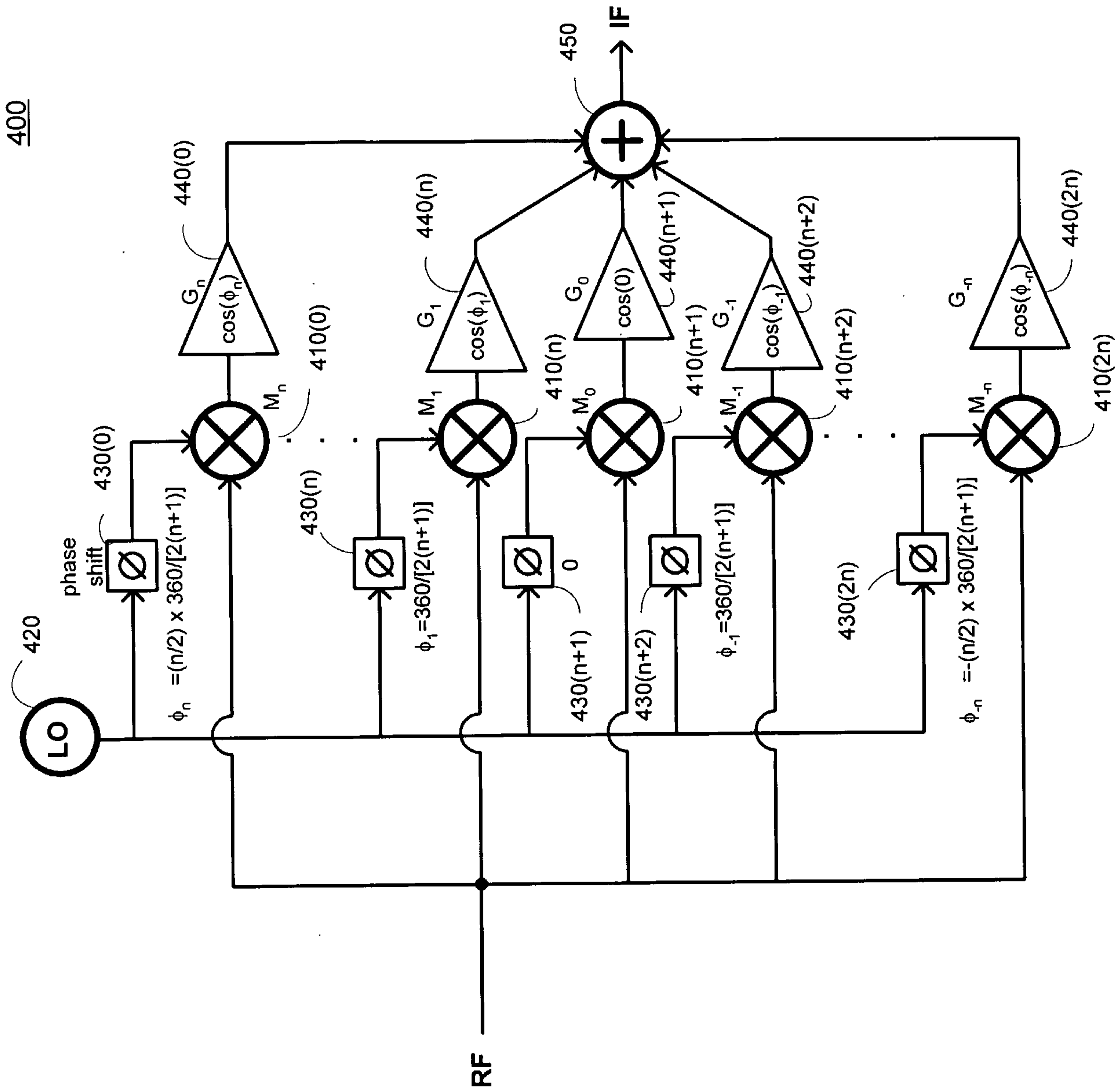

FIG. 4

500

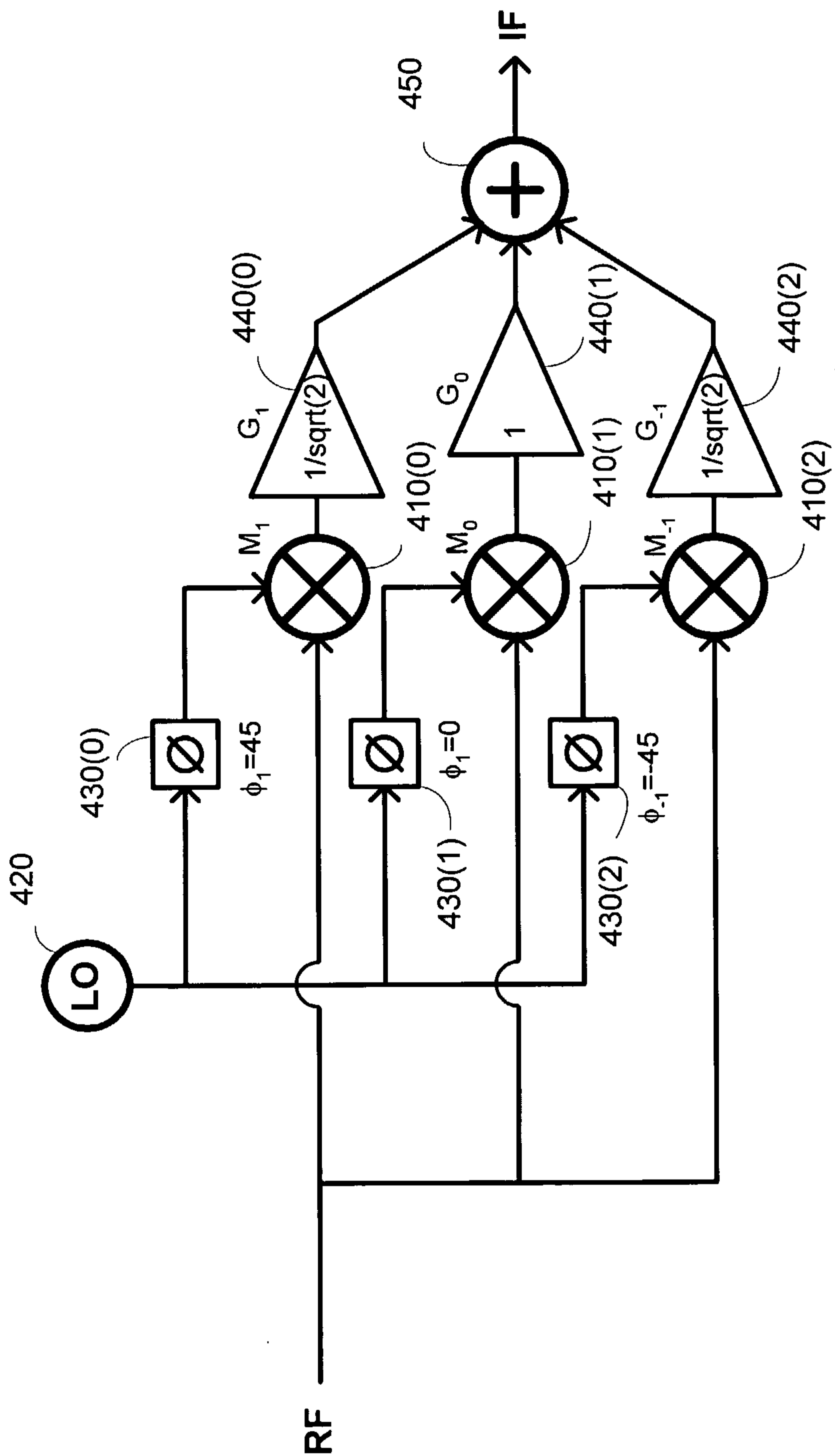

FIG. 5

600

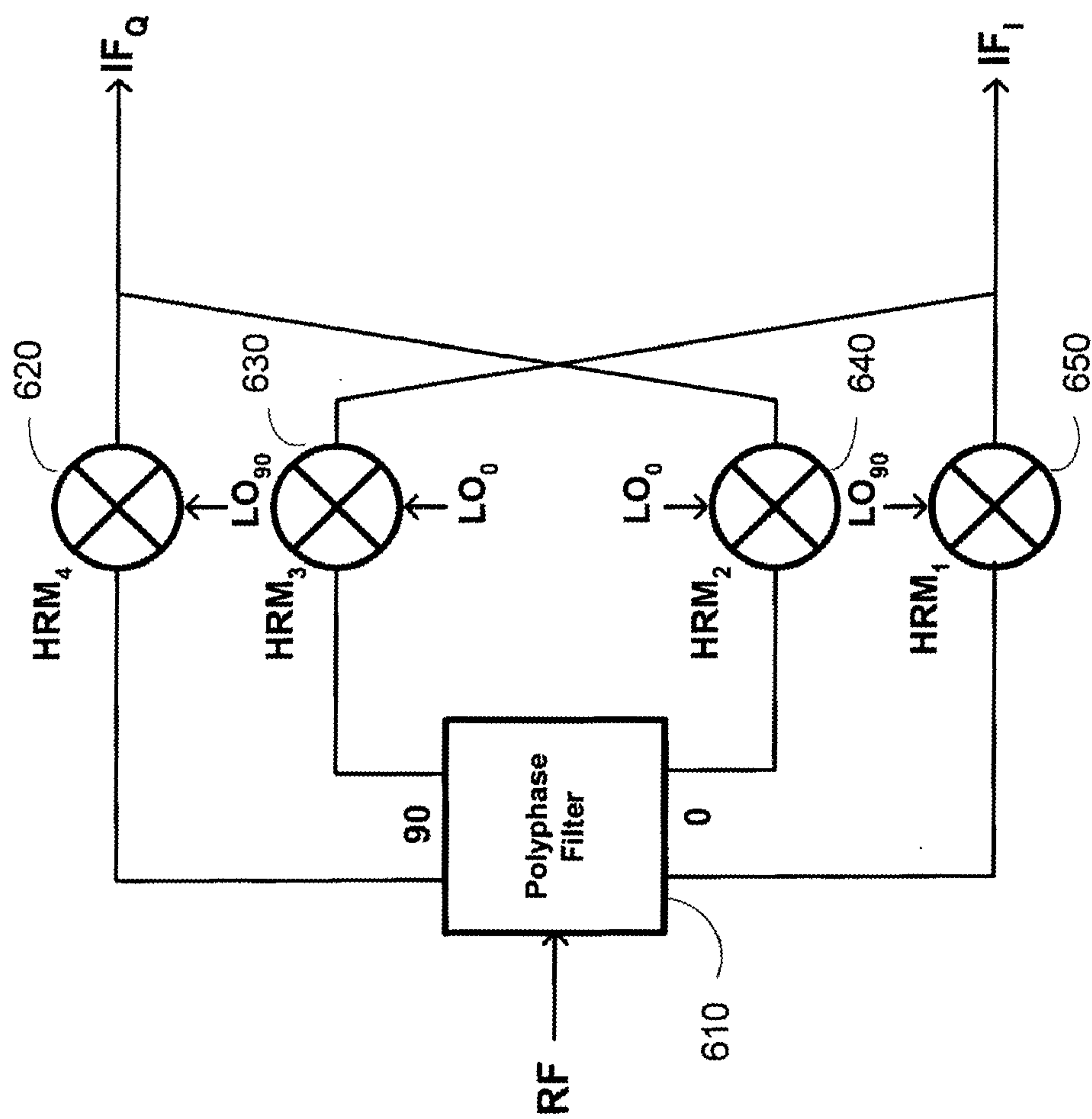

FIG. 6

