



US006224727B1

(12) **United States Patent**
Miyata et al.

(10) **Patent No.:** **US 6,224,727 B1**
(45) **Date of Patent:** **May 1, 2001**

(54) **NO_x SENSOR**

(75) Inventors: **Shigeru Miyata; Masashi Ando; Hiroshi Inagaki**, all of Aichi; **Noboru Ishida**, Gifu; **Takafumi Oshima**, Aichi, all of (JP)

(73) Assignee: **NGK Spark Plug Co., Ltd.**, Nagoya (JP)

(*) Notice: Subject to any disclaimer, the term of this patent is extended or adjusted under 35 U.S.C. 154(b) by 0 days.

(21) Appl. No.: **09/050,079**

(22) Filed: **Mar. 30, 1998**

(30) **Foreign Application Priority Data**

Mar. 28, 1997 (JP) 9-077680

(51) **Int. Cl.⁷** **G01N 27/26**

(52) **U.S. Cl.** **204/425; 204/426; 205/781**

(58) **Field of Search** **504/421-429**

(56) **References Cited**

U.S. PATENT DOCUMENTS

4,272,329	*	6/1981	Hetrick et al.	204/425
4,502,939	*	3/1985	Holfelder et al.	204/426
4,722,779	*	2/1988	Yamada et al.	204/425
4,836,906	*	6/1989	Yamada et al.	204/425
4,859,307	*	8/1989	Nishizawa et al.	204/426
5,288,375		2/1994	Logothetis et al.	
5,505,837		4/1996	Friese et al.	
5,672,811	*	9/1997	Kato et al.	204/426

FOREIGN PATENT DOCUMENTS

0 517 366	12/1992	(EP) .
0 678 740	10/1995	(EP) .

0 678 740 A1	10/1995	(EP) .
0 791 826	8/1997	(EP) .
0 810 430	12/1997	(EP) .
95/30146	11/1995	(WO) .

* cited by examiner

Primary Examiner—T. Tung

(74) *Attorney, Agent, or Firm*—Sughrue, Mion, Zinn, Macpeak & Seas, PLLC

(57) **ABSTRACT**

An NO_x sensor capable of accurately determining the concentration of NO_x contained in a gas to be analyzed (measurement gas) using a simple circuit. The NO_x sensor includes a first measurement space and a second measurement space. The first measurement space communicates with the measurement gas via a first diffusion controlling layer, and the second measurement space communicates with the first measurement space via a second diffusion controlling layer. A first pumping current I_{P1} is controlled such that an output from a Vs cell is used as a reference voltage V_{CO} to control the amount of oxygen flowing into the second measurement space at a constant level. A constant voltage is applied to the second pumping cell so as to decompose the NO_x component of the measurement gas contained in the second measurement space, and to pump out the resulting oxygen from the second measurement space. Accordingly, the concentration of NO_x contained in the measurement gas can be obtained from second pumping current I_{P2}. The electrode of the Vs cell located on the side of the first measurement space is formed around the periphery of or on a portion of the diffusion controlling layer of the Vs cell. As a result, the amount of oxygen flowing from the first measurement space into the second measurement space can be accurately determined by means of the Vs cell. Also, the NO_x concentration can be accurately determined without the need for compensation.

3 Claims, 7 Drawing Sheets

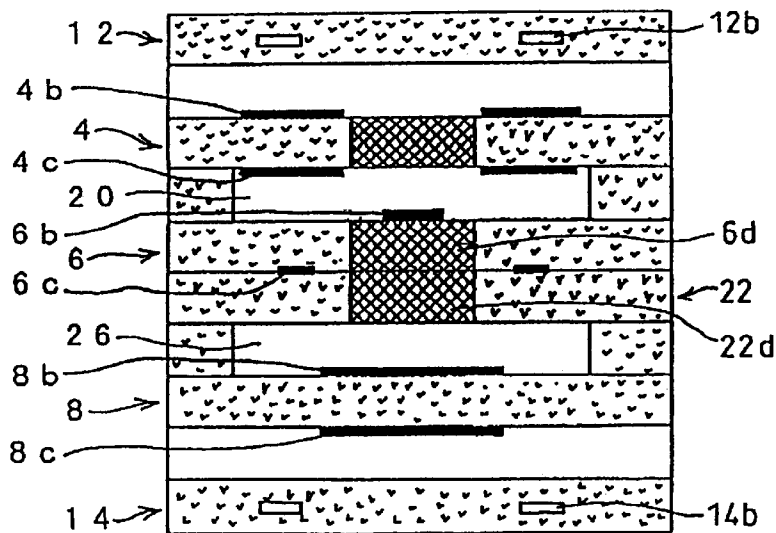

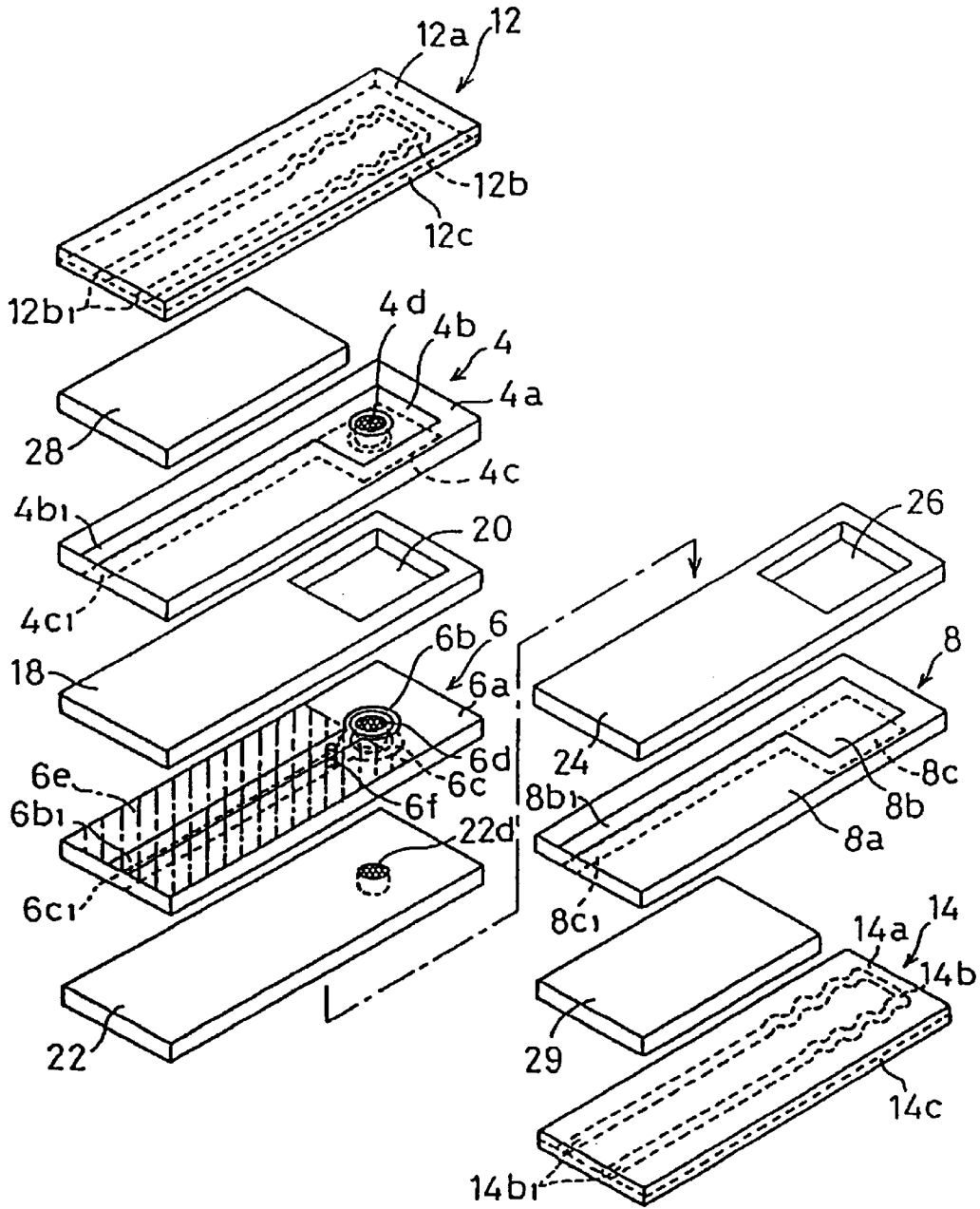

FIG. 1

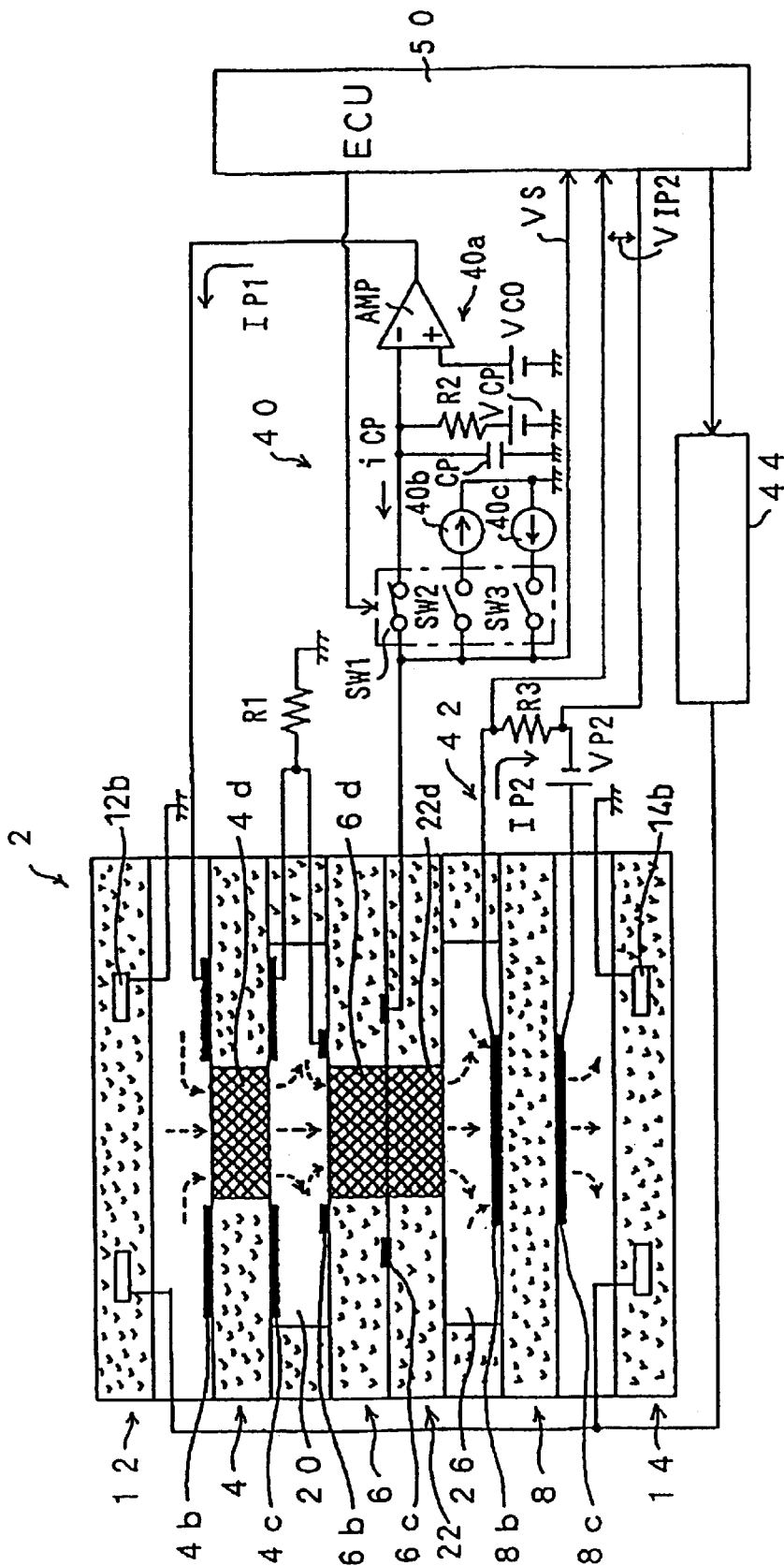

FIG. 2

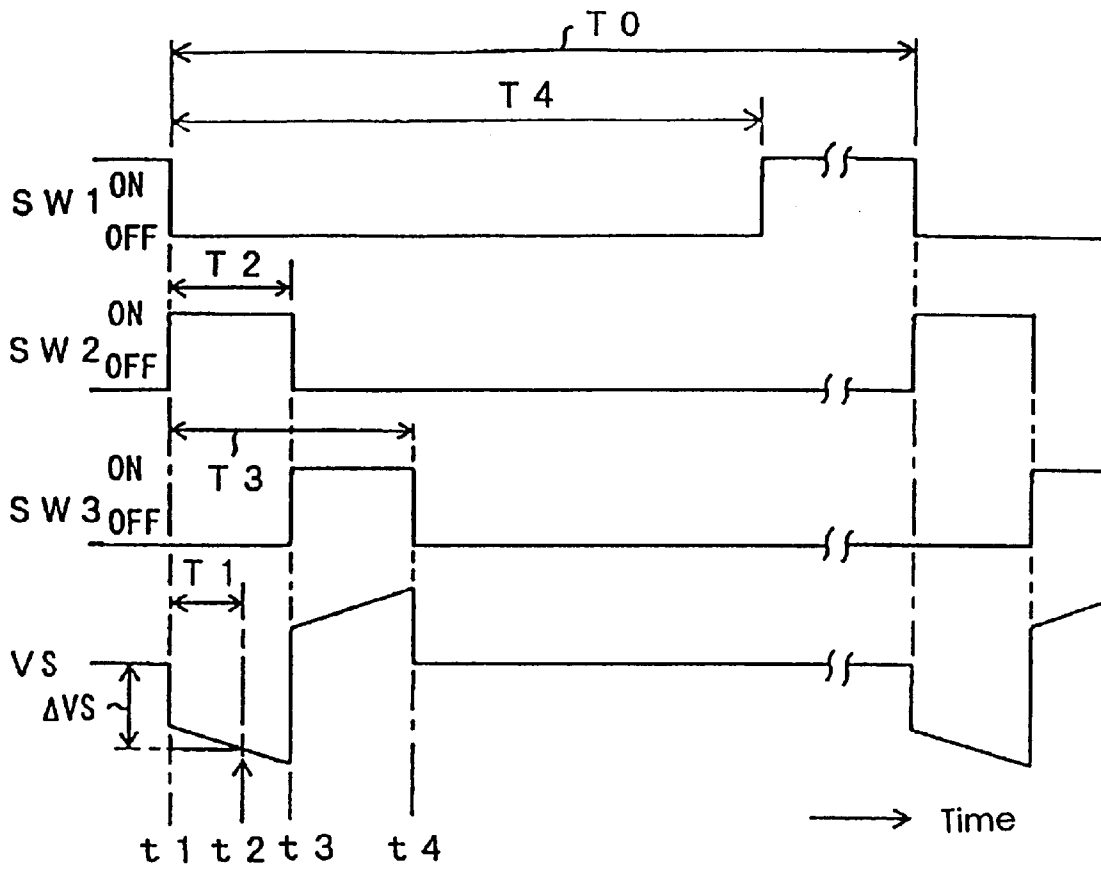

FIG. 3

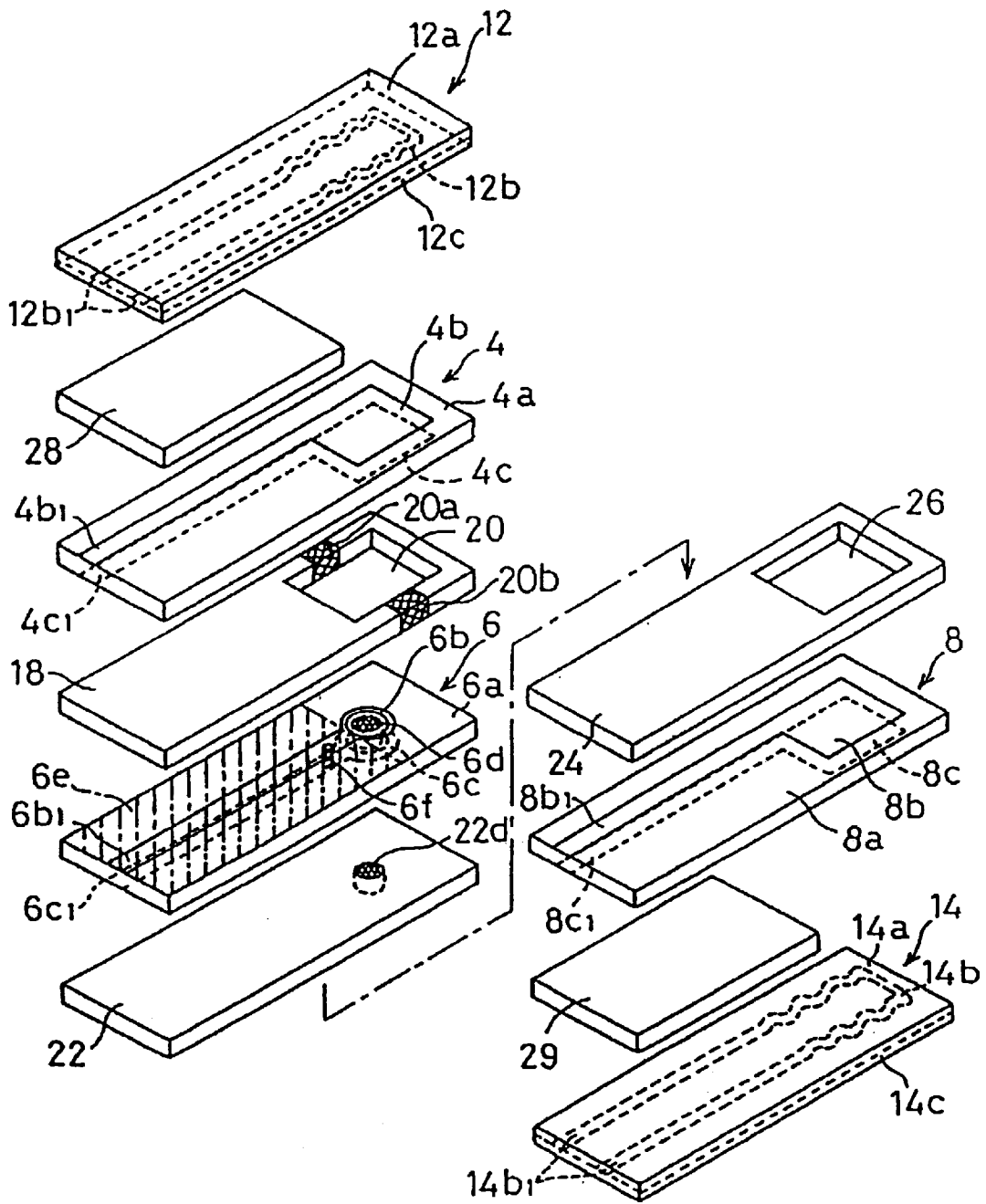

FIG. 4

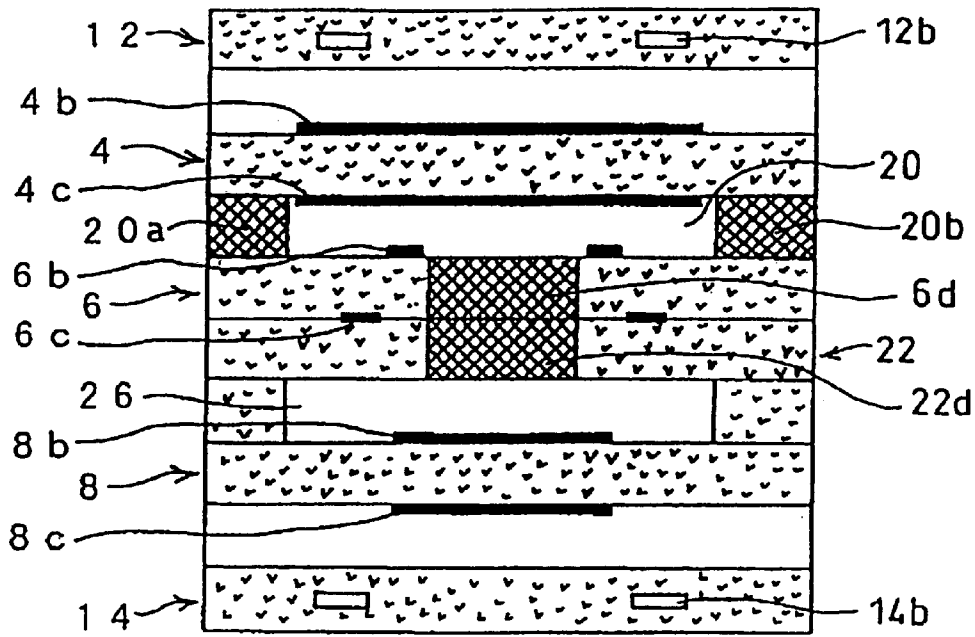

FIG. 5

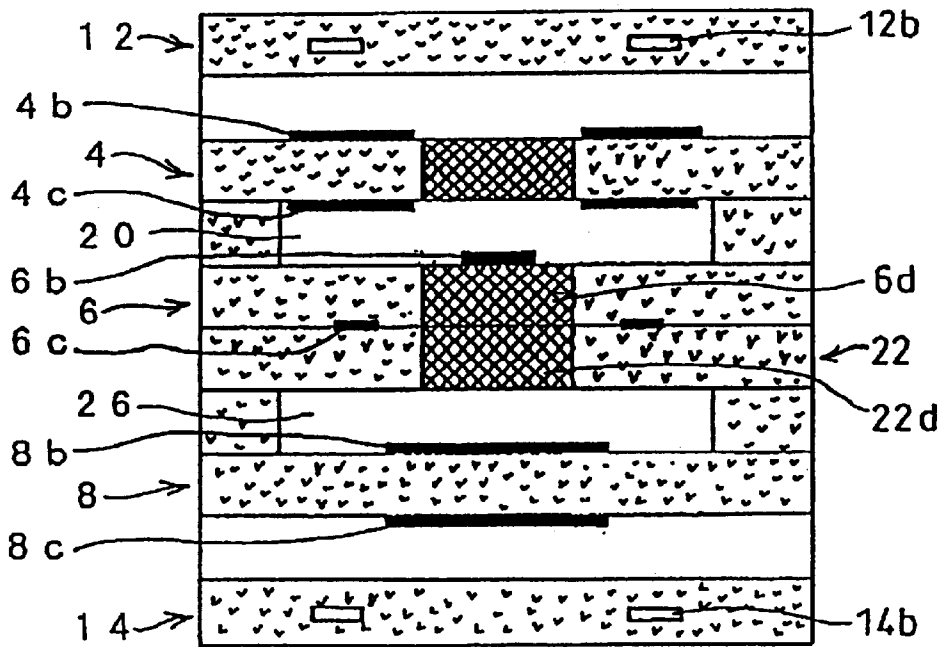

FIG. 6

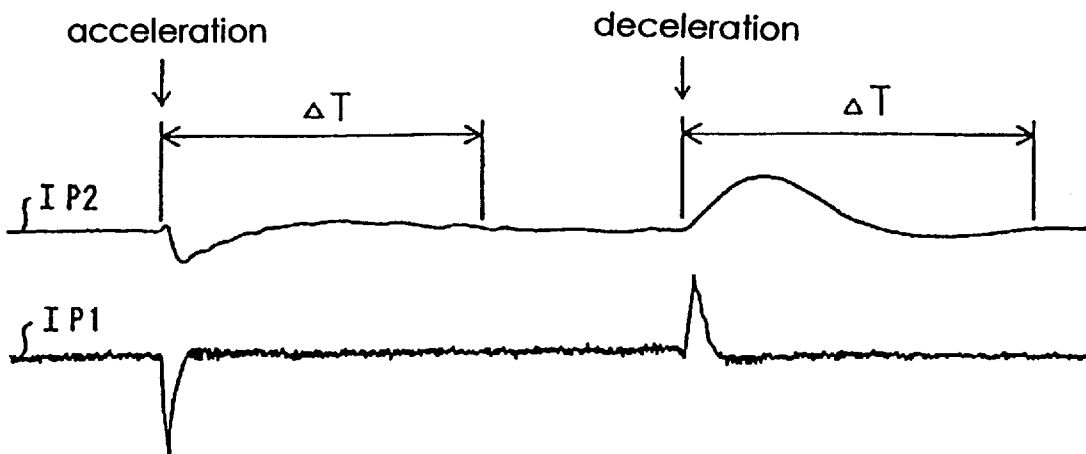

FIG. 7

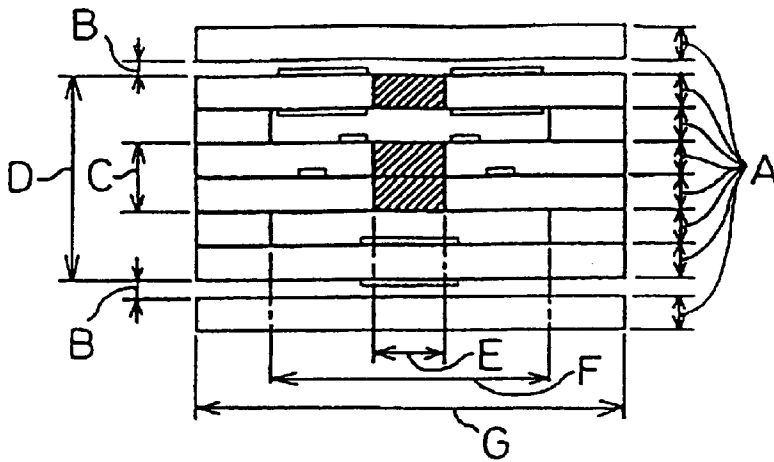

FIG. 8A

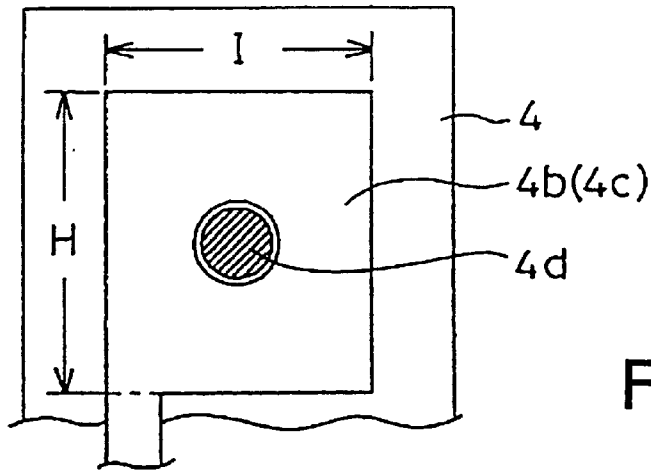

FIG. 8B

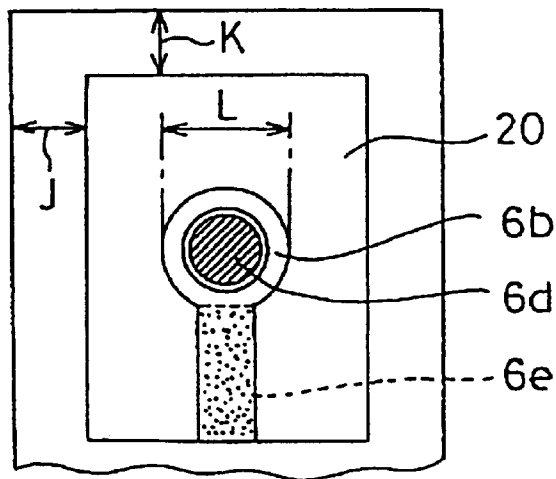

FIG. 8C

NO_x SENSOR

FIELD OF THE INVENTION

The present invention relates to an NO_x sensor for measuring the concentration of nitrogen oxides, or harmful emissions, contained in exhaust gases from various combustion apparatus, including internal combustion engines.

BACKGROUND OF THE INVENTION

NO_x sensors for measuring the concentration of nitrogen oxides (NO_x) contained in gases to be analyzed (hereinafter called "a measurement gas") are disclosed, for example, in European Patent Application Laid-Open No. 0678740A1 and SAE Paper No. 960334, pp. 137-142, 1996. Such conventional NO_x sensors are composed of oxygen ion conductive solid electrolyte layers that form a first measurement space and a second measurement space. The first measurement space communicates with a measurement gas via a first diffusion controlling layer, and the second measurement space communicates with the first measurement space via a second diffusion controlling layer. Furthermore, the solid electrolyte layer of the first measurement space is sandwiched between porous electrodes so as to form a first oxygen pumping cell and an oxygen concentration measuring cell. Also, the solid electrolyte layer of the second measurement space is sandwiched between porous electrodes so as to form a second oxygen pumping cell.

In the thus configured NO_x sensor, the first oxygen pumping cell is energized so that an output voltage from the oxygen concentration measuring cell achieves a predetermined value, to thereby pump out oxygen from the first measurement space and thus control the concentration of oxygen in the first measurement space to a constant level. At the same time, a constant voltage is applied to the second oxygen pumping cell to thereby pump out oxygen from the second measurement space. As a result, the NO_x concentration of the measurement gas can be obtained by measuring the current flowing through the second oxygen pumping cell (hereinafter referred to as "second pumping current").

A measurement gas, e.g., exhaust from an internal combustion engine or the like, contains gas components other than NO_x, such as oxygen, carbon monoxide and carbon dioxide. Thus, in the aforementioned NO_x sensor, current (hereinafter referred to as "first pumping current") is first applied to the first oxygen pumping cell to thereby pump out most of the oxygen from a measurement gas contained in the first measurement space. Then, in the second measurement space into which the oxygen-removed measurement gas flows, NO_x contained in the measurement gas is decomposed into nitrogen and oxygen by means of the catalyzing function of the second oxygen pumping cell. The thus generated oxygen is then pumped out from the second measurement space. Thus, the NO_x concentration of the measurement gas can be obtained by measuring the second pumping current without being affected by other gas components contained in the measurement gas.

In order to accurately measure the NO_x concentration using the above described NO_x sensor, the NO_x sensor must be heated to a predetermined activation temperature (for example, 800° C. or higher) so as to activate the pumping cells. Accordingly, the NO_x sensor is provided with a heater, and current applied to the heater is controlled so as to control the temperature of the NO_x sensor at a predetermined level.

However, in a conventional NO_x sensor, the NO_x concentration obtained from the second pumping current must be appropriately compensated in order to provide an accurate

measurement. This requires a complex signal processing system, with a resulting increase in the cost of the sensing apparatus. The above noted problems are described in detail below.

According to the design concept of a conventional NO_x sensor, oxygen is pumped out from the first measurement space using the first oxygen pumping cell so as to control the measurement gas contained in the first measurement space at a very low oxygen concentration level. As a result, the measurement gas flowing into the second measurement space contains substantially NO_x only. By decomposing the measurement gas into nitrogen and oxygen by means of the catalyzing function of the second oxygen pumping cell, the NO_x concentration can be obtained from the second pumping current flowing through the second oxygen pumping cell.

However, in actuality, if the first oxygen pumping cell is controlled so that the concentration of oxygen contained in the first measurement space becomes substantially zero (theoretically, a partial pressure of about 10⁻⁹ atm), the NO_x concentration cannot be obtained from the second pumping current. Thus, in order to measure the NO_x concentration at a relatively high detection sensitivity using a conventional NO_x sensor, the first oxygen pumping cell must be controlled such that the concentration of oxygen contained in the first measurement space becomes as low as about 1000 ppm.

A reason has been proposed as to why the NO_x concentration cannot be obtained at a good detection sensitivity when the concentration of oxygen in the first measurement space is controlled to be substantially zero. Namely, as a result of controlling the first pumping current, the NO_x component of a measurement gas contained in the first measurement space is decomposed. Consequently, the measurement gas flowing into the second measurement space does not contain NO_x in an amount that is the same as that contained in the actual measurement gas to be analyzed.

Accordingly, when the NO_x concentration is obtained from the second pumping current while the first oxygen pumping cell is controlled such that the concentration of oxygen contained in the first measurement space becomes as low as about 1000 ppm, the second pumping current varies in accordance with the NO_x concentration of the measurement gas. However, the second pumping current is also affected by the oxygen concentration of the measurement gas. This is because the measurement gas flowing from the first measurement space into the second measurement space contains not only NO_x but also oxygen. As a result, conventional NO_x sensors fail to indicate the actual NO_x concentration. This is because the NO_x concentration thus obtained is affected by the oxygen concentration of the measurement gas present around the NO_x sensor.

This problem can be solved, for example, by measuring the oxygen concentration of the measurement gas present around the NO_x sensor based on the first pumping current and compensating the NO_x concentration thus obtained in accordance with the measured oxygen concentration. That is, the first pumping current is controlled so that the concentration of oxygen contained in the first measurement space is maintained at a constant level. Also, the value of the first pumping current is proportional to the oxygen concentration of the measurement gas present around the NO_x sensor. Thus, by obtaining the oxygen concentration of the ambient atmosphere from the first pumping current and thereby compensating the measured NO_x concentration, an accurate NO_x concentration can be obtained.

However, in order to compensate the measured NO_x concentration by obtaining the oxygen concentration of the measurement gas as described above, additional compensation means are required which leads to an increase in the cost of the sensing apparatus. The present invention has been accomplished in view of the above described problems of the prior art.

SUMMARY OF THE INVENTION

It is thereof an object of the present invention to provide an NO_x sensor capable of accurately measuring the NO_x concentration of a measurement gas using a relatively simple circuit, and without the need for compensating the NO_x concentration obtained from the second pumping current in accordance with the oxygen concentration of the measurement gas.

The above objectives of the present invention have been achieved by providing an NO_x sensor for measuring the NO_x concentration of a measurement gas comprising a first measurement space and a second measurement space. The first measurement space includes a first oxygen pumping cell and an oxygen concentration measuring cell, and communicates with the measurement gas via a first diffusion controlling layer. The first oxygen pumping cell comprises an oxygen ion conductive solid electrolyte layer and porous electrodes disposed on opposite surfaces of the oxygen ion conductive solid electrolyte layer. The oxygen concentration measuring cell comprises an oxygen ion conductive solid electrolyte layer and porous electrodes disposed on opposite surfaces of the oxygen ion conductive solid electrolyte layer. The second measurement space includes a second oxygen pumping cell and communicates with the first measurement space via a second diffusion controlling layer. The second oxygen pumping cell comprises an oxygen ion conductive solid electrolyte layer and porous electrodes disposed on opposite surfaces of the oxygen ion conductive solid electrolyte layer. Oxygen is pumped out from the first measurement space by means of the first oxygen pumping cell such that an output voltage from the oxygen concentration measuring cell is maintained at a constant value. A constant voltage is applied to the second oxygen pumping cell in a polarity such that oxygen is pumped out from the second measurement space, whereby the concentration of NO_x contained in the measurement gas can be determined by measuring the current flowing through the second oxygen pumping cell. Preferably, the oxygen concentration measuring cell is disposed in a position such that the amount of oxygen contained in the measurement gas flowing from the first measurement space into the second measurement space via the second diffusion controlling layer can be determined without being affected by the distribution of oxygen within the first measurement space.

BRIEF DESCRIPTION OF THE DRAWINGS

FIG. 1 is an exploded perspective view showing the structure of an NO_x sensor according to an embodiment of the present invention;

FIG. 2 is a schematic diagram showing the entire configuration of an NO_x sensing apparatus employing the NO_x sensor according to an embodiment of the present invention;

FIG. 3 is a timing chart in accordance with the present invention showing a heater energizing control operation as carried out by an ECU (electronic control unit) for controlling the sensor temperature;

FIG. 4 is an exploded perspective view showing the structure of an NO_x sensor in which first diffusion controlling layers are provided at opposing side edges of the sensor;

FIG. 5 is a sectional view showing the electrode arrangement of the NO_x sensor of FIG. 4;

FIG. 6 is a sectional view showing the electrode arrangement of an NO_x sensor in which the electrode located on the side of a first measurement space constituting a Vs cell is formed on a second diffusion controlling layer;

FIG. 7 is a timing chart showing the variation in the measured NO_x concentration (second pumping current) in accordance with the transient fluctuation of a measurement gas; and

FIGS. 8A–8C are views showing the dimensional relationships of the NO_x sensors used in the Examples.

DESCRIPTION OF THE PREFERRED EMBODIMENTS

In the NO_x sensor of the present invention, the oxygen concentration measuring cell is preferably disposed in a position such that the amount of oxygen contained in the measurement gas flowing from the first measurement space into the second measurement space via the second diffusion controlling layer can be determined without being affected by the distribution of oxygen within the first measurement space. This configuration is employed for the reason described below.

In a conventional NO_x sensor, the oxygen concentration measuring cell is disposed so as to determine the concentration of oxygen contained in the first measurement space. By contrast, in the NO_x sensor of the present invention, the oxygen concentration measuring cell is disposed so as to determine the amount of oxygen flowing from the first measurement space into the second measurement space. Thus, the oxygen concentration of the measurement gas flowing into the second measurement space can be accurately determined. Accordingly, the first oxygen pumping cell can be controlled such that the oxygen concentration of the measurement gas flowing into the second measurement space becomes substantially zero.

As discussed above, in a conventional NO_x sensor, if the first oxygen pumping cell is controlled such that the concentration of oxygen contained in the first measurement space becomes substantially zero (theoretically, a partial pressure of about 10⁻⁹ atm), the NO_x concentration cannot be accurately determined from the second pumping current. Thus, the first oxygen pumping cell is controlled so that the concentration of oxygen contained in the first measurement space becomes as low as about 1000 ppm. The cause for this failure in the ability to accurately determine the NO_x concentration has been considered to be as follows. Namely, if the first oxygen pumping cell is controlled such that the concentration of oxygen contained in the first measurement space becomes substantially zero, the NO_x component of the measurement gas contained in the first measurement space is decomposed. Consequently, the measurement gas flowing into the second measurement space does not contain NO_x in the same amount as contained in the actual gas to be analyzed.

The present inventors studied the above described phenomena and discovered the following. In a conventional NO_x sensor, the electrode of the oxygen concentration measuring cell located on the side of the first measurement space has a relatively large size so as to detect the concentration of oxygen contained in the first measurement space by means of the oxygen concentration measuring cell. Consequently, the average concentration of oxygen contained in the first measurement space can be determined, but the concentration of oxygen contained in the measurement

gas flowing from the first measurement space into the second measurement space cannot be determined. That is, because an external measurement gas flows into the first measurement space via the first diffusion controlling layer and because oxygen is pumped out from the incoming measurement gas by means of the first oxygen pumping cell, the distribution of oxygen within the first measurement space becomes nonuniform. As a result, in a conventional NO_x sensor, the concentration of oxygen contained in the measurement gas flowing from the first measurement space into the second measurement space cannot be determined by the oxygen concentration measuring cell.

Thus, in the present invention, the oxygen concentration measuring cell is disposed so as to determine the amount of oxygen flowing from the first measurement space into the second measurement space rather than the concentration of oxygen contained in the first measurement space. As a result, the amount of oxygen flowing from the first measurement space to the second measurement space can be accurately determined by means of the oxygen concentration measuring cell.

According to the present invention, by controlling the current applied to the first oxygen pumping cell, the amount of oxygen flowing from the first measurement space into the second measurement space is controlled to substantially zero, so that the measurement gas contained in the second measurement space contains only an NO_x component in the same amount as contained in the external measurement gas. Thus, the NO_x concentration can be accurately determined from the second pumping current.

Because the NO_x concentration can be accurately determined from the second pumping current flowing through the second oxygen pumping cell, the thus obtained NO_x concentration does not need to be compensated in accordance with the concentration of oxygen contained in the measurement gas. Accordingly, the signal processing system for determining the NO_x concentration can be implemented in a simple configuration, and thus the sensing apparatus cost can be reduced.

As in the case of the aforementioned conventional NO_x sensor, the NO_x sensor of the present invention preferably includes heaters for heating the cells to a predetermined activation temperature in order to accurately measure the NO_x concentration.

When heaters for heating and temperature control are provided, the following structure is preferably employed. The first oxygen pumping cell, the oxygen concentration measuring cell and the second oxygen pumping cell are respectively formed of sheet-like solid electrolyte layers. The solid electrolyte layers are arranged in a laminate such that the solid electrolyte layer constituting the first oxygen pumping cell and the solid electrolyte layer constituting the second oxygen pumping cell are arranged as the outer layers of the laminate. A predetermined gap is provided between these outer solid electrolyte layers and the inner solid electrolyte layer or layers, to thereby define first and second measurement spaces. A sheet-like heater substrate having a heater is disposed on both sides of the solid electrolyte layers in the laminating direction such that a predetermined gap is provided between the heater substrate and the solid electrolyte layers. Furthermore, the first diffusion controlling layer is formed in the solid electrolyte layer having the first oxygen pumping cell at a position opposite a central portion of the heater formed in the heater substrate.

According to the NO_x sensor of the present invention as configured above, the solid electrolyte layer constituting the

oxygen concentration measuring cell is interposed between the solid electrolyte layer constituting the first oxygen pumping cell and the solid electrolyte layer constituting the second oxygen pumping cell, and the heater substrate is disposed on both sides of the layered solid electrolytes in the laminating direction. Accordingly, by controlling current applied to the heaters, the cells can be readily controlled to a predetermined temperature. Also, the measurement gas flowing into the first measurement space through the first diffusion controlling layer and flowing further into the second measurement space can be heated to a predetermined temperature. Thus, temperature variations among the cells are less likely to occur, and the cells are less sensitive to the temperature of the measurement gas. Therefore, the accuracy of the NO_x concentration measurement can be improved.

Preferably, the second diffusion controlling layer is formed so as to at least partially overlap the first diffusion controlling layer when the NO_x sensor is projected in the laminating direction. This enables more reliable temperature control of the measurement gas flowing from the first measurement space to the second measurement space to a target temperature. Thus, the accuracy of the NO_x concentration measurement can be improved.

Preferably, the oxygen concentration measuring cell is formed around the periphery of the second diffusion controlling layer. Alternatively, the second diffusion controlling layer is formed of a porous solid electrolyte layer capable of controlling the diffusion of the measurement gas, and the electrode of the oxygen concentration measuring cell located on the side of the first measurement space is formed on the second diffusion controlling layer. Thus, in this embodiment of the present invention, the oxygen concentration measuring cell is disposed in a position such that the amount of oxygen contained in the measurement gas flowing from the first measurement space into the second measurement space can be measured without being affected by the distribution of oxygen within the first measurement space. This enables accurate measurement of the amount of oxygen contained in the measurement gas flowing from the first measurement space into the second measurement space. Accordingly, the above described effects can be reliably achieved.

Various embodiments of the present invention are described below with reference to the drawings. However, the present invention should not be construed as being limited thereto.

FIG. 1 shows the structure of an NO_x sensor according to one embodiment of the present invention. FIG. 2 shows the entire configuration of an NO_x sensing apparatus employing the NO_x sensor.

As shown in FIG. 1, the NO_x sensor 2 includes a first oxygen pumping cell (hereinafter referred to as a first pumping cell) 4, an oxygen concentration measuring cell (hereinafter referred to as a Vs cell) 6, a second oxygen pumping cell (hereinafter referred to as a second pumping cell) 8, and a pair of heaters 12 and 14 for heating the cells.

The first pumping cell 4 includes a sheet-like solid electrolyte layer 4a and rectangular porous electrodes 4b and 4c formed on both sides of the solid electrolyte layer 4a. Lead portions 4b1 and 4c1 extend from the porous electrodes 4b and 4c, respectively. Furthermore, a round hole is formed in the solid electrolyte layer 4a in such manner as to penetrate the porous electrodes 4b and 4c at the central portions thereof. The thus formed round hole is filled with a porous filler comprising, for example, alumina to thereby form a diffusion controlling layer 4d.

The Vs cell 6 includes a sheet-like solid electrolyte layer 6a similar to the solid electrolyte layer 4a of the first pumping cell 4 and circular porous electrodes 6b and 6c formed on both sides of the solid electrolyte layer 6a. Lead portions 6b1 and 6c1 extend from the porous electrodes 6b and 6c, respectively. Furthermore, a round hole is formed in the solid electrolyte layer 6a in such manner as to penetrate the porous electrodes 6b and 6c at the central portions thereof. The thus formed round hole is filled with a porous filler comprising, for example, alumina to thereby form a diffusion controlling layer 6d.

The porous electrodes 4b and 4c of the first pumping cell 4 and the porous electrodes 6b and 6c of the Vs cell 6 are located on the solid electrolyte layers 4a and 6a, respectively, such that their centers are aligned with each other. Accordingly, when the first pumping cell 4 and the Vs cell 6 are arranged as a laminate, the diffusion controlling layers 4d and 6d face each other. The circular porous electrodes 6b and 6c of the Vs cell 6 are arranged around the diffusion controlling layer 6d and have a size smaller than that of the rectangular porous electrodes 4b and 4c of the first pumping cell 4. Particularly, the porous electrode 6b located on the side of the first pumping cell 4 is formed within a very narrow range around the periphery of the diffusion controlling layer 6d in order to accurately detect the amount of oxygen flowing into the diffusion controlling layer 6d.

An insulation film 6e comprising zirconia or the like is formed on both surfaces of the Vs cell 6 so as to cover the lead portions 6b1 and 6c1 from the outside in order to prevent current leakage from the lead portions 6b1 and 6c1 and to accurately detect the amount of oxygen flowing into the diffusion controlling layer 6d. Furthermore, a leakage resistance portion 6f is formed between the lead portions 6b1 and 6c1 in order to leak part of the pumped out oxygen from the side of the porous electrode 6c to the side of the porous electrode 6b.

The first pumping cell 4 and the Vs cell 6 are arranged in a laminate with a solid electrolyte layer 18 interposed therebetween. The solid electrolyte layer 18 has the same shape as that of the solid electrolyte layers 4a and 6a. The solid electrolyte layer 18 has a rectangular opening formed therein in a position corresponding to the porous electrodes 4c and 6b and has a size greater than that of the porous electrode 4c. The thus formed rectangular opening serves as a first measurement space 20.

Also, a solid electrolyte layer 22, which has the same shape as that of the solid electrolyte layers 4a and 6a, is disposed on the Vs cell 6 on the side of the porous electrode 6c. The solid electrolyte layer 22 has a round hole formed therein in a position corresponding to the diffusion controlling layer 6d of the Vs cell 6. The thus formed round hole is filled with a porous filler comprising alumina or the like to thereby form a diffusion controlling layer 22d.

As in the first pumping cell 4, the second pumping cell 8 includes a sheet-like solid electrolyte layer 8a and rectangular porous electrodes 8b and 8c formed on both sides of the solid electrolyte layer 8a. Lead portions 8b1 and 8c1 extend from the porous electrodes 8b and 8c, respectively. The second pumping cell 8 and the solid electrolyte layer 22 are arranged in layers with a solid electrolyte layer 24 interposed therebetween. The solid electrolyte layer 24 is formed in the same manner as the solid electrolyte layer 18. As a result, a rectangular opening formed in the solid electrolyte layer 24 serves as a second measurement space 26.

Heaters 12 and 14 are placed on opposite sides of the above described laminate of the first pumping cell 4, the Vs cell 6, and the second pumping cell 8, namely, outside the first pumping cell 4 and the second pumping cell 8, respectively, such that a predetermined gap is formed between each of the heaters 12 and 14 and the laminate via spacers 28 and 29.

The heater 12 (14) includes heater substrates 12a and 12c (14a and 14c) having a shape similar to that of the solid electrolyte layers 4a, 6a, . . . , a heater wiring 12b (14b), and a lead portion 12b1 (14b1) extending from the heater wiring 12b (14b). The heater wiring 12b (14b) and the lead portion 12b1 (14b1) are interposed between the heater substrates 12a and 12c (14a and 14c). The spacer 28 (29) is interposed between the heater 12 (14) and the first pumping cell 4 (second pumping cell 8) so that the heater 12 (14) faces the porous electrode 4b (8c) of the first pumping cell 4 (second pumping cell 8) with a gap formed therebetween.

Typical examples of the solid electrolyte constituting the solid electrolyte layers 4a, 6a, . . . include a solid solution of zirconia and yttria and a solid solution of zirconia and calcia. Other examples of the solid electrolyte include a solid solution of hafnia, a solid solution of a perovskite oxide, and a solid solution of a trivalent metal oxide. The porous electrodes provided on the surfaces of the solid electrolyte layers 4a, 6a, and 8a are preferably formed of platinum or rhodium having a catalytic function or alloys thereof. Known methods of forming such porous electrodes include a thick film forming method and a thermal spraying method. The thick film forming method includes the steps of: mixing platinum powder and powder of the same material as that of the solid electrolyte layers to obtain a paste; screen printing the paste onto a solid electrolyte layer; and sintering the solid electrolyte layer. The diffusion controlling layers 4d, 6d, and 22d are preferably formed of ceramics having fine through holes or porous ceramics.

The heater wirings 12b and 14b of the heaters 12 and 14, respectively, are preferably formed of a composite material of ceramics and platinum or a platinum alloy. The lead portions 12b1 and 14b1 are preferably formed of platinum or a platinum alloy in order to reduce an electric loss therein by reducing their resistance. The heater substrates 12a, 12b, 14a and 14c and the spacers 28 and 29 may be formed of alumina, spinel, forsterite, steatite, zirconia, or the like.

Particularly preferably, the heater substrates and spacers are formed of zirconia because the heaters and pumping cells can be concurrently united by sintering to thereby facilitate the manufacture of the NO_x sensor 2. In this case, an insulation layer (formed of alumina or the like) is interposed between the heater substrate 12a (12c) and the heater wiring 12b including the lead portion 12b1 and between the heater substrate 14a (14c) and the heater wiring 14b including the lead portion 14b1.

When the heater substrates are formed of alumina, the spacers are preferably formed of a porous material in order to prevent cracking which would otherwise occur during sintering of the heater substrates and the pumping cells due to differences in the respective coefficients of contraction or thermal expansion. Alternatively, the heaters and the pumping cells may be sintered separately, and then they may be bonded using cement or a like inorganic material serving as both a spacer and a bonding material.

As shown in FIG. 2, an NO_x sensing apparatus employing the NO_x sensor 2 having the above-described structure for measuring the NO_x concentration includes: a drive circuit 40 for applying current to the first pumping cell 4 and Vs cell

6 of the NO_x sensor 2 and for switching one current application path to the other; a sensing circuit 42 for detecting current (second pumping current) I_{P2} which flows to the second pumping cell 8 of the NO_x sensor 2 when a constant voltage is applied to the second pumping cell 8; a heater energizing circuit 44 for heating the cells 4, 6 and 8 by applying current to the heaters 12 and 14 of the NO_x sensor 2; and an electronic control unit (hereinafter referred to as an ECU) 50, which includes a microcomputer, for driving and controlling the drive circuit 40 and the heater energizing circuit 44, and for calculating the concentration of NO_x contained in a measurement gas based on a detection signal V_{IP2} issued from the sensing circuit 42.

As shown in FIG. 2, the porous electrode 4c of the first pumping cell 4 and the porous electrode 6b of the Vs cell 6, both of which are located on the side of the first measurement space 20, are grounded via a resistor R1. The other porous electrodes 4b and 6c are connected to the drive circuit 40.

The drive circuit 40 includes a control section 40a which, in turn, includes a resistor R2 and a differential amplifier AMP. A constant voltage V_{CP} is applied to one end of the resistor R2, and the other end of the resistor R2 is connected to the porous electrode 6c of the Vs cell 6 via a switch SW1. The negative input terminal of the differential amplifier AMP is connected to the porous electrode 6c of the Vs cell 6 via the switch SW1 and to one end of a capacitor Cp. A reference voltage V_{C0} is applied to the positive input terminal of the differential amplifier AMP. The output terminal of the differential amplifier AMP is connected to the porous electrode 4b of the first pumping cell 4. The other end of the capacitor Cp is grounded.

When the switch SW1 is in the ON state, the control section 40a operates in the following manner.

First, a constant small current i_{CP} is supplied to the Vs cell 6 via the resistor R2 to thereby pump out oxygen from the first measurement space 20 into the porous electrode 6c. Because the porous electrode 6c is blocked by the solid electrolyte layer 22 and communicates with the porous electrode 6b via the leakage resistance portion 6f, the concentration of oxygen contained in the blocked space of the porous electrode 6c is maintained at a constant level by applying the small current i_{CP} to the Vs cell 6. Thus, the blocked space serves as an internal reference oxygen source.

When the porous electrode 6c of the Vs cell serves as an internal reference oxygen source, an electromotive force is generated in the Vs cell 6 in accordance with the difference in oxygen concentration between the first measurement space 20 and the internal reference oxygen source. As a result, a voltage V_s generated on the side of the porous electrode 6c corresponds to the concentration of oxygen contained in the first measurement space 20. Because the voltage V_s is applied to the input of the differential amplifier AMP, the differential amplifier AMP outputs a voltage in accordance with the deviation of the input voltage from the reference voltage V_{C0} (V_{C0}—input voltage). The output voltage is applied to the porous electrode 4b of the first pumping cell 4.

As a result, a current I_{P1} (hereinafter referred to as first pumping current I_{P1}) flows to the first pumping cell 4. By controlling the first pumping current I_{P1}, a constant electromotive force is generated in the Vs cell 6. That is, the control section 40a controls the pumping out of oxygen from the first measurement space 20 such that a predetermined amount of oxygen is pumped out from the first measurement space 20 into the second measurement space 26 via the

diffusion controlling layers 6d and 22d serving as the second diffusion controlling layer.

The thus controlled amount of oxygen flowing from the first measurement space 20 into the second measurement space 26 is set to substantially zero (theoretically, a partial pressure of about 10⁻⁹ atm). The reference voltage V_{C0} which determines the amount of oxygen flowing from the first measurement space 20 into the second measurement space 26 is set at approximately 450 mV.

The drive circuit 40 further includes a constant current circuit 40b and a constant current circuit 40c. The constant current circuit 40b is connected to the porous electrode 6c of the Vs cell 6 via a switch SW2 and causes a constant current to flow between the porous electrodes 6b and 6c in a direction opposite that of the small current i_{CP}. The constant current circuit 40c is connected to the porous electrode 6c of the Vs cell 6 via a switch SW3 and causes a constant current to flow between the porous electrodes 6b and 6c in the same direction as that of the small current i_{CP}.

The constant current circuits 40b and 40c are adapted to detect the internal resistance R_{VS} of the Vs cell 6. To allow the ECU 50 to detect the internal resistance R_{VS} of the Vs cell 6 by supplying a constant current to the Vs cell 6, the voltage V_s generated on the side of the porous electrode 6c is input to the ECU 50. The constant current circuits 40b and 40c supply a constant current of the same value in opposite directions. The value of the constant current is greater than that of the small current i_{CP}, which is supplied to the Vs cell 6 via the resistor R2.

The switches SW1, SW2 and SW3 provided between the porous electrode 6c of the Vs cell 6 and the control section 40a and the constant current circuits 40b and 40c, respectively, are turned ON or OFF in accordance with a control signal issued by the ECU 50. In the normal mode where the NO_x concentration is determined by means of the control section 40a, only the switch SW1 is turned ON. Only when the internal resistance R_{VS} of the Vs cell 6 is to be detected, the switch SW1 is turned OFF, and the switches SW2 and SW3 are sequentially turned ON in this order.

A constant voltage V_{P2} is applied between the porous electrodes 8b and 8c of the second pumping cell 8 of the NO_x sensor 2 via a resistor R3, which is a component of the sensing circuit 42 and serves as a constant voltage application means. The constant voltage V_{P2} is applied to the second pumping cell 8 in a polarity such that the porous electrodes 8c and 8b become a positive electrode and a negative electrode, respectively. As a result, current flows from the porous electrode 8c to the porous electrode 8b to thereby pump out oxygen from the second measurement space 26. The constant voltage V_{P2} is set at a voltage, for example 450 mV, such that the NO_x component contained in the measurement gas flowing from the first measurement space 20 into the second measurement space via the diffusion controlling layers 6d and 22d is decomposed in the second measurement space, and the resulting oxygen component is pumped out from the measurement gas.

The resistor R3 is adapted to convert the second pumping current I_{P2} flowing through the second pumping cell 8 as a result of applying the constant voltage V_{P2} to a voltage V_{IP2}, and is adapted to input the voltage V_{IP2} to the ECU 50 as a detection signal corresponding to the second pumping current I_{P2}.

In the NO_x sensing apparatus having the above described configuration, by turning switch SW1 ON and switches SW2 and SW3 OFF, the control section 40a can control the amount of oxygen contained in the measurement gas at

substantially zero when the measurement gas flows from the first measurement space **20** into the second measurement space **26** via the diffusion controlling layers **6d** and **22d** (second diffusion controlling layer). The measurement gas initially flows into the first measurement space **20** via the diffusion controlling layer **4d** (first diffusion controlling layer). Accordingly, the second pumping current I_{P2} flowing through the second pumping cell **8** varies in accordance with the NO_x concentration, while the concentration of oxygen contained in an ambient measurement gas hardly affects the second pumping current I_{P2} . Thus, by reading the detection signal V_{IP2} corresponding to the second pumping current I_{P2} , and carrying out a predetermined computation based on the read signal, the ECU **50** can determine the concentration of NO_x contained in the measurement gas from the detection signal V_{IP2} (in other words, the second pumping current I_{P2}).

In order to accurately measure the NO_x concentration, the temperature of the cells **4**, **6** and **8**, and particularly the temperature of the Vs cell **6** adapted to detect the concentration of oxygen contained in the first measurement space **20**, is preferably controlled at a constant value. Thus, the amount of current applied to the heaters **12** and **14** by the heater energizing circuit **44** must be controlled such that the temperature of the Vs cell **6** achieves a target value. To attain this end, the ECU **50** carries out heater energizing control processing at predetermined intervals T0 as well as NO_x concentration measuring processing. In the NO_x concentration measuring processing, the ECU **50** turns the switch SW1 ON and the switches SW2 and SW3 OFF, and then reads the detection signal V_{IP2} corresponding to the second pumping current I_{P2} in order to measure the concentration of NO_x contained in the measurement gas. In the heater energizing control processing, the ECU **50** turns the switch SW1 OFF and the switches SW2 and SW3 ON/OFF in order to detect the sensor temperature based on the internal resistance R_{VS} of the Vs cell **6**, and controls the amount of current supplied from the heater energizing circuit **44** to the heaters **12** and **14** such that the detected sensor temperature achieves a target value (for example, 850°C).

That is, as shown in FIG. **3**, upon starting the heater energizing operation control processing (at time t1), the ECU **50** reads the voltage Vs generated by the porous electrode **6c** of the Vs cell **6** and turns the switch SW1 OFF and the switch SW2 ON, to thereby cause a constant current to flow in the Vs cell **6** in a direction opposite that of the small current i_{CP} . Subsequently, after the elapse of a predetermined time T1 (for example, $60\ \mu\text{sec}$), i.e., at time t2, the ECU **50** reads the voltage Vs again. After the elapse of a predetermined time T2 (for example, $100\ \mu\text{sec}$) of the control processing, i.e., at time t3, the ECU **50** turns the switch SW2 OFF and the switch SW3 ON, to thereby cause a constant current to flow in the Vs cell **6** in the same direction as that of the small current i_{CP} (i.e., in a direction pumping out oxygen from the first measurement space **20** into a blocked space). Then, after the elapse of a predetermined time T3 (for example, $200\ \mu\text{sec}$) of the control processing, i.e., at time t4, the ECU **50** turns the switch SW3 OFF. Furthermore, after the elapse of a predetermined time T4 (for example, $500\ \mu\text{sec}$) of the control processing, the ECU **50** turns the switch SW1 ON, thus returning to the NO_x concentration measuring processing.

During execution of the heater energizing operation control processing, the ECU **50** calculates the internal resistance R_{VS} of the Vs cell **6** from the differential voltage ΔV_s between the voltage Vs generated by the porous electrode **6c** as detected at time t1 and at time t2. The ECU **50** controls

the amount of current supplied from the heater energizing circuit **44** to the heaters **12** and **14** such that the calculated internal resistance R_{VS} achieves a target value. As a result, the amount of current supplied to the heaters **12** and **14** is controlled such that the internal resistance R_{VS} of the Vs cell **6** (i.e., the sensor temperature) is maintained at a constant value. Accordingly, the temperature of NO_x sensor **2** becomes constant.

As described above, in the NO_x sensing apparatus of the present embodiment, the porous electrode **6b** of the Vs cell **6** located on the side of the first pumping cell **4** is formed within a very narrow range along the periphery of the diffusion controlling layer **6d**. Accordingly, the amount of oxygen flowing from the first measurement space **20** into the second measurement space **26** can be accurately measured. Also, when the NO_x concentration is to be measured, the first pumping current I_{P1} is controlled such that an output voltage from the Vs sensor **6** becomes the reference voltage V_{CO} . As a result, the amount of oxygen flowing from the first measurement space **20** into the second measurement space **26** becomes substantially zero.

Thus, according to the present invention, the NO_x concentration can be accurately determined from the second pumping current I_{P2} without being affected by the concentration of oxygen contained in the measurement gas. Also, because there is no need to compensate the NO_x concentration as determined from the second pumping current I_{P2} in accordance with the concentration of oxygen contained in the measurement gas, the sensing apparatus can be simply configured.

In the above embodiment, the diffusion controlling layer (first diffusion controlling layer) **4d** is formed at the center of the electrodes **4b** and **4c** of the first pumping cell **4** so as to face the heater **12** (specifically, the center of the heater wiring **12b**). However, for example, as shown in FIGS. **4** and **5**, diffusion controlling layers **20a** and **20b** serving as the first diffusion controlling layer may be formed at the side portions of the solid electrode layer **18** which defines the first measurement space **20**, to thereby pump in the measurement gas through the side portions of the NO_x sensor **2**.

Also, in the above embodiment, the porous electrode **6b** of the Vs cell **6** located on the side of the first pumping cell **4** is formed around the periphery of the diffusion controlling layer **6d** in order to accurately detect the amount of oxygen flowing from the first measurement space **20** into the second measurement space **26**. However, for example, as shown in FIG. **6**, the porous electrode **6b** in a yet further preferred embodiment may be formed on the diffusion controlling layer **6d**. In this case, in order to generate a voltage between the electrodes **6b** and **6c** in accordance with the amount of oxygen flowing into the second measurement space **26**, the diffusion controlling layer **6d** must be formed of a porous solid electrolyte (zirconia or the like) capable of controlling diffusion of a measurement gas.

Except for the above-noted portions, the NO_x sensor shown in FIGS. **4-6** has a structure similar to that of the NO_x sensor **2** shown in FIGS. **1** and **2**. Thus, a detailed description of the NO_x sensor of FIGS. **4-6** is omitted.

EXAMPLES

Next, the degree of improvement in NO_x concentration measurement accuracy is shown below as a function of the location of the porous electrode **6b** of the Vs cell **6**, and specifically a location around the periphery of the diffusion controlling layer **6d** or on the diffusion controlling layer **6d**, by reference to the following experimental results. However,

the present invention should not be construed as being limited thereto.

The experiment involved two types of NO_x sensors, namely, the NO_x sensor of the first embodiment shown in FIGS. 1 and 2 (an NO_x sensor in which the first diffusion controlling layer faces the heater 12), and the NO_x sensor of the second embodiment shown in FIGS. 4 and 5 (an NO_x sensor in which the first diffusion controlling layer is located at the side edges of the NO_x sensor). For each type were manufactured an NO_x sensor including a porous electrode 6b having a diameter of 2 mm, an NO_x sensor including a porous electrode 6b having a diameter of 1 mm, and an NO_x sensor including a porous electrode 6b formed on the second diffusion controlling layer as shown in FIG. 6. The thus manufactured six kinds of NO_x sensors were attached to the exhaust pipe of an internal combustion engine. The average time ΔT that elapsed until the measured NO_x concentration (i.e., the measured second pumping current I_{P2}) became stable was measured during acceleration and deceleration of the internal combustion engine (FIG. 7).

As a result, as shown in Table 1, among the NO_x sensors in which the porous electrode 6b was formed around the periphery of the diffusion controlling layer 6d, the NO_x sensor having the smaller sized porous electrode 6b exhibited a shorter ΔT under transient conditions of the measurement gas (under transient conditions, both the temperature and oxygen concentration may vary). Also, the NO_x sensors in which the porous electrode 6b was formed on the diffusion controlling layer 6d exhibited a shorter ΔT as compared with the NO_x sensors in which the porous electrode 6b was formed around the periphery of the diffusion controlling layer 6d. This is because when the porous electrode 6b is located closer to the diffusion controlling layer 6d, the amount of oxygen flowing from the first measurement space 20 into the second measurement space 26 can be determined more accurately. As a result, the NO_x concentration measurement is less affected by variations in the concentration of oxygen contained in the measurement gas.

Also, as seen from Table 1, the NO_x sensors of the first embodiment, in which the first diffusion controlling layer faces the heater 12, exhibited a shorter ΔT under transient measurement gas conditions as compared with the NO_x sensors of the second embodiment, in which the first diffusion controlling layer was located at the side edges of the NO_x sensor. This is because by having the first diffusion controlling layer and the heater 12 face each other, the measurement gas flowing into the first measurement space 20 can be heated by the heater 12. As a result, the NO_x concentration measurement is less affected by variations in the temperature of the measurement gas.

TABLE 1

(Measurement of fluctuation time ΔT of I _{P2} under transient conditions)		
Porous electrode 6b	First embodiment	Second embodiment
Diameter: 2 mm	40 sec	65 sec
Diameter: 1 mm	20 sec	35 sec
Located on second diffusion controlling layer	12 sec	20 sec

As shown in FIG. 8A, the dimensions of the NO_x sensors of the first embodiment as used in the above experiment were as follows: The thickness A of the heaters 12 and 14 and the thickness A of the solid electrolyte layers 4a, 6a, 8a,

18, 22 and 24 that formed the first pumping cell 4, the Vs cell 6, the second pumping cell 8, the first measurement space 20, the diffusion controlling layer 22d and the second measurement space 26, respectively, were each 0.25 mm. The thickness B of the spacers 28 and 29 that determine the gap between the heater 12 and the first pumping cell 4 and between the heater 14 and the second pumping cell 8 was 0.1 mm. Accordingly, the thickness D of the NO_x sensor body excluding the heaters 12 and 14 was 1.5 mm. Also, the thickness C of the second diffusion controlling layer comprising the diffusion controlling layers 6d and 22d was 0.5 mm.

The diameter of the diffusion controlling layers 4d, 6d and 22d was 0.5 mm; the width F of the first and second measurement spaces 20 and 26, respectively, as measured in the lateral direction of the NO_x sensor was 2.5 mm; and the width G of the NO_x sensor was 3.5 mm. As shown in FIG. 8B, the width I of the porous electrodes 4b and 4c formed around the diffusion controlling layer (first diffusion controlling layer) was 2.4 mm; and the length H of the porous electrodes 4b and 4c as measured in the longitudinal direction of the NO_x sensor was 3.0 mm.

As shown in FIG. 8C, the rectangular hole serving as the first measurement space 20 was formed in the solid electrolyte layer 18 such that distance K from the top end of the NO_x sensor was 0.5 mm and the distance J from either side edge of the NO_x sensor was 0.5 mm. The porous electrode 6b formed around the periphery of the diffusion controlling layer 6d had a diameter L of 2 mm or 1 mm. The porous electrode 6b formed on the diffusion controlling layer 6d had a diameter of 0.4 mm.

The NO_x sensors of the second embodiment used in the experiment had dimensions identical to those of the NO_x sensors of the first embodiment except for the following dimensions. The diffusion controlling layers 20a and 20b (first diffusion controlling layer) formed at the side portions of the NO_x sensor had a length of 1 mm as measured in the longitudinal direction of the NO_x sensor. The porous electrodes 4b and 4c of the first pumping cell measured 2.4 mm×3.0 mm and were formed in a solid manner.

It should further be apparent to those skilled in the art that various changes in form and detail of the invention as shown and described above may be made. It is intended that such changes be included within the spirit and scope of the claims appended hereto.

What is claimed is:

1. An NO_x sensor for measuring the NO_x concentration of a measurement gas, comprising:
 - 50 solid electrolyte layers arranged in the form of a laminate having a laminating direction,
 - a first measurement space including a first oxygen pumping cell and an oxygen concentration measuring cell and communicating with the measurement gas via a first diffusion controlling layer, said first oxygen pumping cell comprising an oxygen ion conductive solid electrolyte and porous electrodes disposed on opposite surfaces of the oxygen ion conductive solid electrolyte layer, and said oxygen concentration measuring cell comprising an oxygen ion conductive solid electrolyte layer and porous electrodes disposed on opposite surfaces of the oxygen ion conductive solid electrolyte layer;
 - a second measurement space including a second oxygen pumping cell and communicating with said first measurement space via a second diffusion controlling layer, said second oxygen pumping cell comprising an oxy-

15

gen ion conductive solid electrolyte layer and porous electrodes disposed on opposite surfaces of the oxygen ion conductive solid electrolyte layer;

wherein the electrode layers are arranged in the form of a laminate having a laminating direction,

means for maintaining an output voltage of said oxygen concentration measuring cell at a constant value, which means comprises said first oxygen pumping cell for pumping cell for pumping oxygen from said first measurement space; and

means for applying a constant voltage to said second oxygen pumping cell for pumping oxygen from said second measurement space, whereby the concentration of NO_x contained in the measurement gas can be determined by measuring the current flowing through said second oxygen pumping cell; and

wherein said oxygen concentration measuring cell is disposed in a position such that the amount of oxygen contained in the measurement gas flowing from said first measurement space into said second measurement space via said second diffusion controlling layer can be determined without being affected by the distribution of oxygen within said first measurement space; and

wherein said second diffusion controlling layer comprises a porous solid electrolyte layer capable of controlling diffusion of the measurement gas, and the electrode of said oxygen concentration measuring cell located on the side of said first measurement space is formed on a portion of said second diffusion controlling layer; and

wherein said second diffusion controlling layer at least partially overlaps said first diffusion controlling layer in the laminating direction of said laminate.

2. An NO_x sensor for measuring the NO_x concentration of a measurement gas, comprising:

a first measurement space including a first oxygen pumping cell and an oxygen concentration measuring cell, said first measurement space communicating with the measurement gas via a first diffusion controlling layer, said first oxygen pumping cell comprising an oxygen ion conductive solid electrolyte layer and porous electrodes disposed on opposite surfaces of the oxygen ion conductive solid electrolyte layer, and said oxygen concentration measuring cell comprising an oxygen ion

16

conductive solid electrolyte layer and porous electrodes disposed on opposite surfaces of the oxygen ion conductive solid electrolyte layer; and

a second measurement space including a second oxygen pumping cell and communicating with said first measurement space via a second diffusion controlling layer of a solid electrolyte material, said oxygen pumping cell comprising an oxygen ion conductive solid electrolyte layer and porous electrodes disposed on opposite surfaces of the oxygen ion conductive solid electrolyte layer;

wherein the solid electrolyte layers are arranged in the form of a laminate having a laminating direction,

wherein the electrode of said oxygen concentration measuring cell located on the side of said first measurement space is formed on a portion of said second diffusion controlling layer; and

wherein said second diffusion controlling layer at least partially overlaps said first diffusion controlling layer in the laminating direction of said laminate.

3. The NO_x sensor as claimed in claim 2, wherein the solid electrolyte layers include at least one inner layer, the first measurement space is defined by a gap provided between the solid electrolyte layer constituting said first oxygen pumping cell and the at least one inner layer, and the second measurement space is defined by a gap provided between the solid electrolyte layer constituting said second oxygen pumping cell and the at least one inner layer; and

wherein said at least one inner solid electrolyte layer includes an inner layer having a third diffusion controlling layer formed therein arranged between the solid electrolyte layer constituting the oxygen concentration measuring cell and the solid electrolyte layer constituting the second oxygen pumping cell, and the second measurement space is defined by a gap provided between the solid electrolyte layer constituting said second oxygen pumping cell and said inner solid electrolyte layer having the third diffusion controlling layer; and

wherein said first, second and third diffusion controlling layers at least partially overlap each other in the laminating direction of said laminate.

* * * * *