

M. B. SMITH.

Car Coupling.

No. 111,985.

Patented Feb. 21, 1871.

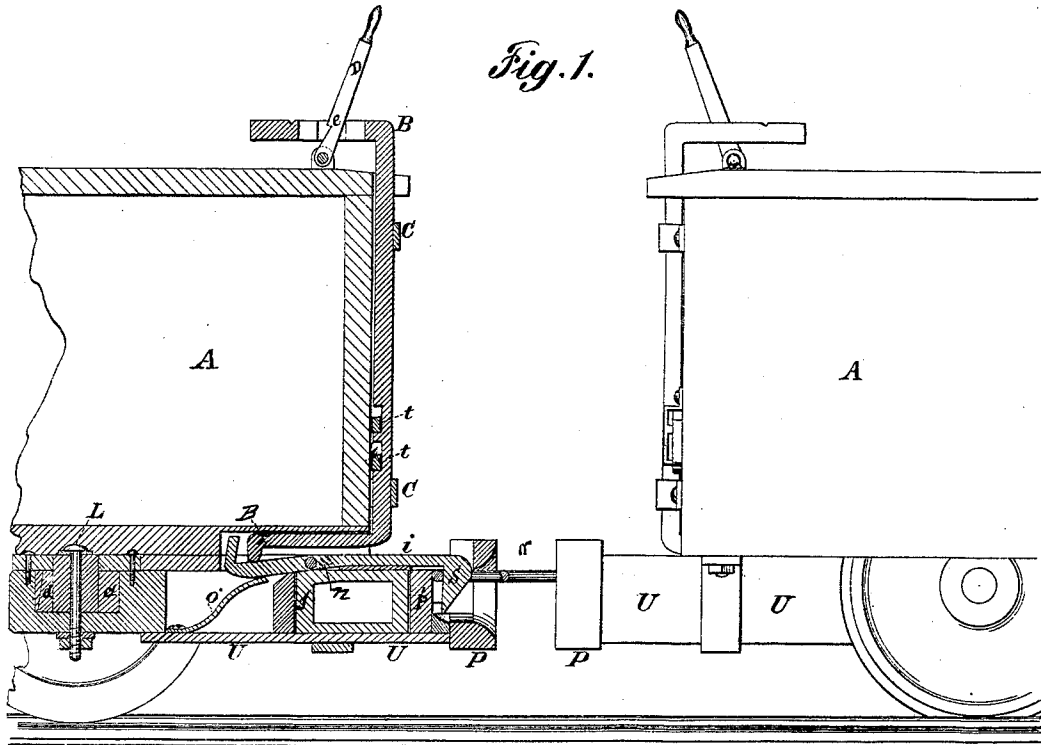

Fig. 1.

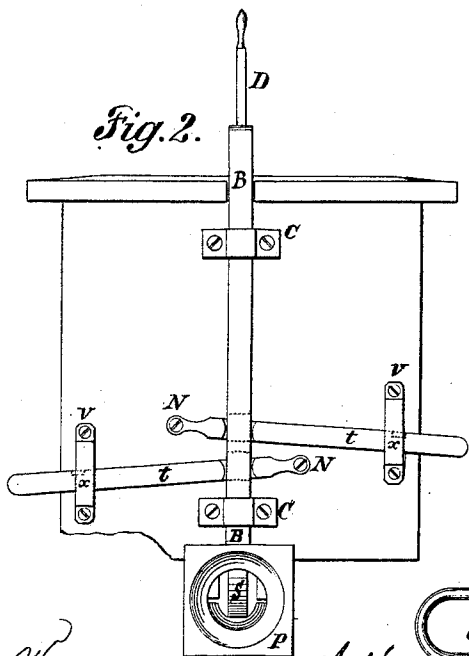

Fig. 2.

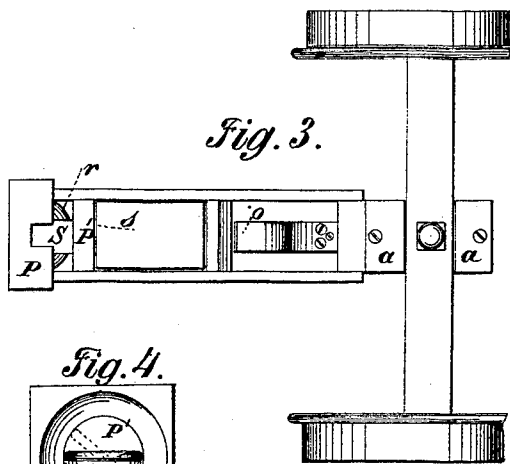

Fig. 3.

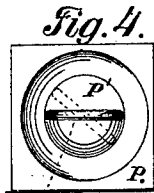

Fig. 4.



Fig. 5.

Inventor:
Marcus B. Smith

Witnesses: { Fred. Acto's
Thomas Taylor, Jr.

United States Patent Office.

MARCUS B. SMITH, OF MATTOON, ILLINOIS.

Letters Patent No. 111,985, dated February 21, 1871.

IMPROVEMENT IN RAILWAY-CAR COUPLINGS.

The Schedule referred to in these Letters Patent and making part of the same.

I, MARCUS B. SMITH, of Mattoon, in the county of Coles and State of Illinois, have invented certain Improvements in Car-Couplers, of which the following is a specification.

My invention relates to an improvement in car-couplers; and

It consists in a combination of three levers, secured in positions by clasps, and so arranged on the ends of a car that when one of them is pressed downward it will operate on a fourth lever, depressing its rear end, thereby unlocking the coupling-hook.

On the top of the car is a small upright lever, having a notch near its center, and is used to hold down the main lever, thereby rendering the coupling device inoperative when desired.

The locking device is attached to the draw-bar. It is a lever, the front end of which has a hook-head device. It is held in position by a pin or fulcrum passing through a point near its center. It is operated by the main lever depressing the rear end of it, which unhooks the head from the coupling-link.

A solid metal bumper is secured on the fore end of the draw-bar arrangement to receive the first shock of concussion; but the concussion is further modified by an arrangement of springs placed within a casing in connection with the draw-bar.

My car-coupling device will couple at any angle desired, and readily unhook one from the other by the action of a car turning over, thereby saving a whole train of cars.

In the accompanying drawing—

Figure 1 is a side longitudinal sectional view, showing the coupling-link secured by the hook-head.

Figure 2 is an end view of the car, showing the arrangement of the exterior working levers.

Figure 3 is a top interior view of the springs and bumpers.

Figure 4 is an end-view of the connecting-link and principal bumper.

Figure 5 is the connecting-link disengaged.

A A, fig. 1, the body of the car.

B B, the main central lever, supported in position by the metal clasps *c c*.

D is a lever used to hold the upright lever B B in position by means of the notch *e*.

t t are two levers which act in combination with lever B B.

i is a lever and hook-head combined. This lever is supported by fulcrum *n*.

S, the hook-head or coupler.

r, the connecting-link.

U U, the draw-bar case, which contains an arrangement of springs to deaden the shock of concussion.

L, a bolt, securing the draw-bar case to the bottom of the car.

o is a spring, the lower end of which is secured on the bottom of the draw-bar case, while its upper end supports the rear end of lever *i*, thereby depressing the hook-head device and locking the link *r*.

P is an exterior bumper, and

P' is an interior bumper.

s, a rubber or metallic spring.

a a, a spring, such as is usually employed on a draw-bar, and may be of metal or rubber.

D, fig. 2, the lever described.

B B, the central upright lever.

t t, the side levers, held in position by clasps V V and fulcrum N N.

P, the exterior bumper, and

S, the hook-head.

X X are catches attached to the clasps V V, one to each, and are used to hold down the levers *t t* when it is necessary to keep the couplers unhooked.

P, fig. 3, is a top view of the exterior bumper.

r, the coupling-ring.

S, the hook-head.

P', the interior bumper.

s, the rubber spring.

o, a spring, and

a a, the rear spring described.

P, fig. 4, is an end view of the bumper, and

r, an end view of the connecting-link.

P' is the interior bumper, which receives the concussion of the connecting-link on the shock of locking.

r, fig. 5, is a plane top view of the connecting-link.

In operation, when the two cars approach each other, one will have a link, *r*, secured in position by the hook-head S. On striking the hook-head with the link the former will rise by the action of the link on its wedge-shaped front, when the link will become locked by the falling of the hook-head, thus attaching the two cars together. When it is necessary to uncouple it is only necessary for the brakeman on the top of the car to press downward the lever B B with his foot, which in turn will raise the hook-head S by depressing the rear end of the lever *i*, and thereby relieve the link *r*. The levers *t t*, each of them, (fig. 2,) if pressed downward, will operate in like manner by acting on B B. Their usefulness is apparent, as one operates from each side.

When the cars approach each other to be hooked together, as has been described, they may strike with such force that the bumpers P P may come in contact end to end. In that case the force of concussion will be communicated to the rear-end spring *a a* in the usual manner.

When the link *r* strikes the bumper P' the spring *s* will receive the shock of concussion, which is very

great, and bumper P will receive a secondary shock, as has been described.

I do not claim as new self-locking car-couplers, so arranged that, when pushed against each other, they will become engaged.

I claim as my invention—

The combination of the lever B B, secured in position by plates c c, in combination with the levers t t, i, and D, and notch e, when combined in the manner

substantially as described, in combination with the bumper P, draw-bar U U, and spring s, to receive the shock of concussion from the link r, when operated in the manner and for the purposes as herein set forth and described.

MARCUS B. SMITH.

Witnesses:

WM. E. HENRY,
C. L. SMITH.