

(12) INTERNATIONAL APPLICATION PUBLISHED UNDER THE PATENT COOPERATION TREATY (PCT)

(19) World Intellectual Property
Organization
International Bureau



(10) International Publication Number
WO 2018/019761 A1

(43) International Publication Date
01 February 2018 (01.02.2018)

(51) International Patent Classification:

C07C 5/48 (2006.01) B01J 8/06 (2006.01)
C07C 11/04 (2006.01)

TR), OAPI (BF, BJ, CF, CG, CI, CM, GA, GN, GQ, GW,
KM, ML, MR, NE, SN, TD, TG).

(21) International Application Number:

PCT/EP2017/068615

Declarations under Rule 4.17:

— as to applicant's entitlement to apply for and be granted a patent (Rule 4.17(ii))

(22) International Filing Date:

24 July 2017 (24.07.2017)

Published:

— with international search report (Art. 21(3))

(25) Filing Language:

English

(26) Publication Language:

English

(30) Priority Data:

16181303.5 26 July 2016 (26.07.2016) EP

(71) Applicant (for all designated States except US): **SHELL INTERNATIONALE RESEARCH MAATSCHAPPIJ B.V.** [NL/NL]; Carel van Bylandtlaan 30, 2596 HR THE HAGUE (NL).

(71) Applicant (for US only): **SHELL OIL COMPANY** [US/US]; SHELL PLAZA 1, HOUSTON, Texas 77252-2463 (US).

(72) Inventors: **BOS, Alouisius, Nicolaas, Renée**; Grasweg 31, 1031HW Amsterdam (NL). **STEPHENS, Ryan, Mark**; 14115 Edinburg Court, Houston, Texas 77077 (US). **VAN ROSSUM, Guus**; Grasweg 31, 1031HW Amsterdam (NL).

(74) Agent: **MATTHEZING, Robert, Maarten**; Shell Internationale Research Maatschappij B.V., PO Box 384, 2501 CJ THE HAGUE (NL).

(81) Designated States (unless otherwise indicated, for every kind of national protection available): AE, AG, AL, AM, AO, AT, AU, AZ, BA, BB, BG, BH, BN, BR, BW, BY, BZ, CA, CH, CL, CN, CO, CR, CU, CZ, DE, DJ, DK, DM, DO, DZ, EC, EE, EG, ES, FI, GB, GD, GE, GH, GM, GT, HN, HR, HU, ID, IL, IN, IR, IS, JO, JP, KE, KG, KH, KN, KP, KR, KW, KZ, LA, LC, LK, LR, LS, LU, LY, MA, MD, ME, MG, MK, MN, MW, MX, MY, MZ, NA, NG, NI, NO, NZ, OM, PA, PE, PG, PH, PL, PT, QA, RO, RS, RU, RW, SA, SC, SD, SE, SG, SK, SL, SM, ST, SV, SY, TH, TJ, TM, TN, TR, TT, TZ, UA, UG, US, UZ, VC, VN, ZA, ZM, ZW.

(84) Designated States (unless otherwise indicated, for every kind of regional protection available): ARIPO (BW, GH, GM, KE, LR, LS, MW, MZ, NA, RW, SD, SL, ST, SZ, TZ, UG, ZM, ZW), Eurasian (AM, AZ, BY, KG, KZ, RU, TJ, TM), European (AL, AT, BE, BG, CH, CY, CZ, DE, DK, EE, ES, FI, FR, GB, GR, HR, HU, IE, IS, IT, LT, LU, LV, MC, MK, MT, NL, NO, PL, PT, RO, RS, SE, SI, SK, SM,

(54) Title: OXIDATIVE DEHYDROGENATION (ODH) OF ETHANE

(57) Abstract: Processes and associated reaction systems for the oxidative dehydrogenation of ethane are provided. In particular, a process is provided that comprises supplying a feed gas comprising ethane and oxygen to a multitubular fixed-bed reactor and allowing the ethane and oxygen to react in the presence of an oxidative dehydrogenation catalyst to yield a reactor effluent comprising ethylene; and supplying a coolant to an interior shell space of the multitubular fixed-bed reactor in a flow pattern that is co-current with the flow of the feed gas through reactor.



WO 2018/019761 A1

- 1 -

OXIDATIVE DEHYDROGENATION (ODH) OF ETHANE

Field of the Invention

The present invention relates to a process for the
5 oxidative dehydrogenation of ethane.

Background

It is known to oxidatively dehydrogenate ethane
resulting in ethylene, in an oxidative dehydrogenation
(oxydehydrogenation; ODH) process. Examples of ethane ODH
10 processes are for example disclosed in US7091377,
WO2003064035, US20040147393, WO2010096909 and US20100256432.
The oxidative dehydrogenation of ethane converts ethane into
ethylene. In this process, ethane is reacted with oxygen in
the presence of an ODH catalyst to produce a product stream
15 comprising predominately ethylene, along with unreacted
reactants (such as ethane and oxygen), and typically other
gases and/or by-products (such as carbon monoxide, carbon
dioxide, water).

In general, the yield of ethylene in an ODH process is
20 reduced by the undesirable combustion reactions of ethane and
ethylene, both of which are highly exothermic and generate
carbon dioxide and/or carbon monoxide. As is generally the
case in such exothermic processes, it is important to control
the reaction temperature within a certain range to maintain
25 effective and safe plant operation and also to extend the life
of the catalyst and inhibit undesirable side reactions. It is
known that a multitubular fixed-bed reactor may be used to
conduct such exothermic reactions, with the reactor employing
a plurality of tubes containing a fixed bed of catalyst
30 particulates, and a shell in which the tubes are contained
through which coolant circulates to facilitate the removal of
the reaction heat.

Typically, it is desirable to maintain isothermal
conditions on the coolant side of the reactor. This is usually

- 2 -

accomplished either by using a boiling medium (e.g. water/steam, kerosene) as the coolant, wherein the low-temperature incoming feed gas is preheated to the reaction temperature at the expense of the coolant which enters the shell at a higher temperature, or by circulating a coolant that is in counter-current flow with the flow of the reactants through the tubes at a sufficiently high circulation rate so as to rapidly remove heat. However, fixed bed reactors used in exothermic reactions may nevertheless have the propensity to develop one or more "hot spots" in various regions of the reactor.

In an attempt to avoid the undesirable formation of a so-called "hot-spot" (a localized temperature peak) in the catalyst bed, one commonly proposed solution is to reduce the diameter of the tubes in order to increase the heat transfer rate per unit volume of the catalyst. However, this typically increases the cost associated with building the reactor and also increases the amount of time required to load and unload the catalyst into the tubes. Similarly, it may also limit somewhat the size/shape of catalyst that can be used. Likewise, if the lengths of the tubes are significantly increased, the pressure drop across the reactor may also undesirably increase. Another commonly proposed solution is to operate at a lower productivity or lower conversion, for example by diluting the catalyst with an inert substance. However, this also has the disadvantage of increased cost and typically increases the difficulty of later recovering the spent catalyst from the reactor for regeneration, if desired.

Accordingly, the present inventors have sought to provide improved processes for the oxidative dehydrogenation of ethane. In particular, the present inventors have sought to provide ODH processes that utilize a multitubular fixed-bed reactor wherein the generation of hot-spots in the

- 3 -

catalyst bed is avoided or reduced, thereby preventing or minimizing the risk of a reactor runaway.

Summary

In one aspect, a process for the oxidative
5 dehydrogenation of ethane to ethylene is provided, the process comprising:

providing a multitubular fixed-bed reactor comprising a reactor inlet, an interior shell space, and a plurality of reactor tubes, wherein the plurality of reactor tubes
10 comprise a catalyst bed that comprises an oxidative dehydrogenation catalyst;

supplying a feed gas comprising ethane and oxygen to the reactor inlet and allowing the ethane and oxygen to react in the presence of the oxidative dehydrogenation catalyst to
15 yield a reactor effluent comprising ethylene; and

supplying a coolant to the interior shell space of the multitubular fixed-bed reactor in a flow pattern that is co-current with the flow of the feed gas through the plurality of reactor tubes.

20 Brief Description of the Drawings

Some specific example embodiments of the disclosure may be understood by referring, in part, to the following description and the accompanying drawing.

Figures 1 and 2 are schematic illustrations showing
25 exemplary embodiments of the present disclosure.

While the present disclosure is susceptible to various modifications and alternative forms, specific example embodiments have been shown in the figure and are herein described in more detail. It should be understood, however,
30 that the description of specific example embodiments is not intended to limit the invention to the particular forms disclosed, but on the contrary, this disclosure is to cover

- 4 -

all modifications and equivalents as illustrated, in part, by the appended claims.

Detailed Description

The present invention makes use of the observation that
5 in an ODH process utilizing a multitubular fixed-bed reactor, hot-spots nearly always occur in an upstream portion of the catalyst bed; hence a low coolant temperature would be best here. However, at such a lower coolant temperature, there is quite some room for an axial temperature increase along the
10 length of the reactor without the risk of a hot-spot forming in the downstream portion of the catalyst bed.

Accordingly, the present inventors have found that by utilizing the processes disclosed herein, it is possible to minimize or avoid the formation of hot-spots in an upstream
15 portion of the catalyst bed, while simultaneously achieving relatively high productivity throughout the entire catalyst bed, without the need to decrease tube diameter and/or increase tube length of the tubes. In particular, it has been found that these advantages may be achieved by supplying a
20 coolant to an interior shell space of a multitubular fixed-bed reactor in a flow pattern where, contrary to normal practice, the isothermicity of the coolant side is deliberately impaired by circulating a coolant that is in co-current flow with the flow of the reactants through the
25 plurality of reactor tubes at what would normally be considered an insufficient flow rate.

In general, coolant is supplied to the reactor at a flow rate that is sufficiently low enough to allow for an increase in the temperature of the coolant, for example an increase of
30 approximately 5 to 30 °C, during its flow through the interior shell space of the reactor (from an upstream coolant inlet positioned at or near the top of the reactor tubes to a downstream coolant outlet positioned at or near the bottom of

- 5 -

the reactor tubes), due to the removal of the reaction heat generated in the upstream portion of the catalyst bed. As such, the reactor is operated in a manner where the isothermicity of the coolant side is deliberately compromised
5 by utilizing co-current coolant flow, at what would generally be considered too low of a flow rate, which thereby conversely allows for the process side to become remarkably isothermal.

In accordance with the oxidative dehydrogenation
10 processes of the present disclosure, a feed gas comprising ethane and oxygen is supplied to the inlet of a multitubular fixed-bed reactor. As used herein, the term "feed gas" is understood to refer to the totality of the gaseous stream(s) at the inlet(s) of the reactor. Thus, as will be appreciated
15 by one skilled in the art, the feed gas is often comprised of a combination of one or more gaseous stream(s), such as an ethane stream, an oxygen-containing stream, a recycle gas stream, etc. Optionally, in addition to ethane and oxygen, the feed gas may further comprise other alkanes (e.g.
20 methane, propane), carbon monoxide, carbon dioxide, hydrogen, steam, an inert gas (such as nitrogen, helium and/or argon), and/or various by-products of the ODH reaction (e.g. acetylene, acetic acid).

In the processes disclosed herein, ethane and oxygen may
25 be added to the reactor as mixed feed, optionally comprising further components therein, at the same reactor inlet. Alternatively, the ethane and oxygen may be added in separate feeds, optionally comprising further components therein, to the reactor at the same reactor inlet or at separate reactor
30 inlets. Further, the order and manner in which the components of the feed gas are supplied to the reactor inlet is not particularly limited, and therefore, the components may be combined simultaneously or sequentially. Further, the

- 6 -

components of the feed gas may optionally be vaporized, preheated and mixed (if desired) prior to being supplied to the reactor inlet using means known to those skilled in the art. For example, preheat techniques may include, for
5 example, heat exchange from steam, a heat transfer fluid (e.g. coolant), reactor effluent, and/or a furnace.

Ethane in the feed gas may be from any suitable source, including natural gas, provided that impurities are sufficiently removed therefrom and may include fresh ethane,
10 a recycle of unreacted ethane from the reactor effluent, or a combination thereof. Similarly, the oxygen may originate from any suitable source, such as air or a high purity oxygen stream. Such high-purity oxygen may have a purity of greater than 90%, preferably greater than 95%, more preferably
15 greater than 99%, and most preferably greater than 99.4%.

In general, the molar ratio of molecular oxygen to ethane in the feed gas at the reactor inlet may be in the range of from 0.01 to 1, more suitably 0.05 to 0.5. Preferably, the feed gas comprises from 5 to 35 vol.% of
20 oxygen, relative to the total volume of the feed gas, more suitably 20 to 30 vol.% of oxygen, and 40 to 80 vol.% of ethane, more suitably 50 to 70 vol.% ethane, and less than 80 (0 to 80) vol.% of an inert gas, more suitably less than 50 (0 to 50) vol.% of an inert gas, more suitably 5 to 35 vol.%
25 of an inert gas, most suitably 10 to 20 vol.% of an inert gas. Suitably, the oxygen concentration in the feed gas should be less than the concentration of oxygen that would form a flammable mixture at either the reactor inlet or the reactor outlet at the prevailing operating conditions.

30 Multitubular fixed-bed reactors suitable for use in the present disclosure are not particularly limited and may include any of a variety known in the art. In general, a suitable multitubular fixed-bed reactor comprises a reactor

- 7 -

inlet, an interior shell space in fluid communication with an upstream coolant inlet and a downstream coolant outlet, and a plurality of reactor tubes, wherein the plurality of reactor tubes comprise a catalyst bed that comprises an oxidative
5 dehydrogenation catalyst. Optionally, in addition to the catalyst bed, the reactor tubes may further comprise a bed of an inert material.

Within the reactor, the upper ends of the reactor tubes are typically fixed in place by an upper tube plate and are
10 in fluid communication with the reactor inlet. Similarly, the lower ends of the reactor tubes are typically fixed in place by a lower tube plate and are in fluid communication with the reactor outlet. Preferably, the reactor tubes are arranged within the reactor in a substantially vertical manner such
15 that they are no more than 5° from vertical, and the upper and lower tube plates are positioned within the reactor in a substantially horizontal manner such that they are no more than 3° from horizontal.

While the size and number of reactor tubes within a
20 multitubular fixed-bed reactor may vary widely from reactor to reactor, a reactor tube used in a commercial reactor may generally have a length of from 1 to 25 meters and an internal tube diameter of from 10 to 80 millimeters. Further, the number of reactor tubes can vary and may range in the
25 thousands, for example up to 50,000.

As previously mentioned, in accordance with the ODH processes of the present disclosure, ethane and oxygen are allowed to react in the presence of an oxidative
dehydrogenation catalyst to yield a reactor effluent
30 comprising ethylene. In general, various ODH processes are known and described in the art and the ODH processes of the present disclosure are not limited in that regard. Thus, the person skilled in the art may conveniently employ any of such

- 8 -

processes in accordance with the ODH processes of the present disclosure. For example, suitable ODH processes, including catalysts and other process conditions, include those described in above-mentioned US7091377, WO2003064035, 5 US20040147393, WO2010096909 and US20100256432, which are herein incorporated by reference.

Suitably, the temperature in the plurality of reactor tubes is in the range of from 100 to 600 °C, preferably in the range of from 200 to 500 °C. Further, the pressure in the 10 plurality of reactor tubes is in the range of from 1 to 30 bara (i.e. "bar absolute"), or from 1 to 20 bara, or from 1 to 15 bara, or from 2 to 10 bara, or from 3 to 10 bara.

Oxidative dehydrogenation catalysts suitable for use in the present disclosure are not particularly limited and may 15 include any ethane oxidative dehydrogenation catalyst. The amount of such catalyst is not essential. Preferably, a catalytically effective amount of the catalyst is used, that is to say an amount sufficient to promote the ethane oxydehydrogenation reaction.

20 Examples of suitable oxidative dehydrogenation catalyst include, but are not necessarily limited to, one or more mixed metal oxide catalyst comprising molybdenum, vanadium, niobium and optionally tellurium as the metals and may have the following formula:

25 $Mo_1V_aTe_bNb_cO_n$

wherein:

a, b, c and n represent the ratio of the molar amount of the element in question to the molar amount of molybdenum (Mo);

30 a (for V) is from 0.01 to 1, preferably 0.05 to 0.60, more preferably 0.10 to 0.40, more preferably 0.20 to 0.35, most preferably 0.25 to 0.30;

b (for Te) is 0 or from >0 to 1, preferably 0.01 to

- 9 -

0.40, more preferably 0.05 to 0.30, more preferably 0.05 to 0.20, most preferably 0.09 to 0.15;

c (for Nb) is from >0 to 1, preferably 0.01 to 0.40, more preferably 0.05 to 0.30, more preferably 0.10 to 0.25,
5 most preferably 0.14 to 0.20; and

n (for O) is a number which is determined by the valency and frequency of elements other than oxygen.

Optionally, a catalyst bed may comprise more than one oxidative dehydrogenation catalyst. For example, in one
10 embodiment, a catalyst bed may comprise a plurality of oxidative dehydrogenation catalysts having varied activity levels (e.g. so as to vary the activity level along the length of the reactor tube). Further, if desired, the catalyst bed may further comprise inert material (e.g. to
15 dilute and/or reduce the activity of the catalyst bed).

Preferably, the oxidative dehydrogenation catalyst is heterogeneous and in the form of particles. Further, preferably, said heterogeneous catalyst is porous, specifically a porous, particulate catalyst.

20 In the processes of the present disclosure, coolant is supplied to the interior shell space of the multitubular fixed-bed reactor in a flow pattern that is co-current with the flow of the feed gas through the plurality of reactor tubes. The coolant may be any fluid suitable for heat
25 transfer, for example, a molten salt or an organic material suitable for heat exchange (e.g. oil, kerosene, etc.). Preferably, cooling in the present process is performed under non-boiling conditions. In particular, it is preferred that in the present process the coolant does not boil.

30 Coolant is supplied to the interior shell space of the reactor at or near the top of the reactor tubes via an upstream coolant inlet. Similarly, coolant is preferably removed from the interior shell space of the reactor at or

- 10 -

near the bottom of the reactor tubes via a downstream coolant outlet. In general, coolant may be supplied to, and removed from, the interior shell space of the reactor in any suitable manner so long as the flow of the coolant is co-current with
5 the flow of the feed gas. Typically, coolant is supplied to the interior shell space of the reactor via a coolant circuit, which optionally comprises one or more cooling apparatus (e.g. heat exchanger, steam drum, etc.) and one or more circulation pumps.

10 Optionally, the interior shell space of the reactor may be divided into two separate regions, an upstream region and a downstream region, by a perforated partition extending transverse to the plurality of reactor tubes. In general, the perforated partition is a plate having a plurality of holes
15 through which the reactor tubes can pass and may be of any suitable material, such as metal (e.g. carbon steel). The perforated partition is typically arranged such that the upstream region is at least 10% of the reactor tube length, or at least 15%, or at least 20%, or at least 25%, on the
20 same basis, and at most 30% of the reactor tube length, or at most 25%, or at most 20%, or at most 15%, on the same basis, or from 10% to 30% of the reactor tube length, or from 10% to 25%, or from 10% to 20%, or from 10% to 15%, or from 15% to 30%, or from 15% to 25%, or from 15% to 20%, on the same
25 basis. Advantageously, by dividing the interior shell space into two separate regions, it may be possible to improve the distribution of the coolant in the reactor, thereby providing more control over the temperature.

In those embodiments where the reactor comprises a
30 perforated partition, the flow of coolant through the interior shell space of the reactor is such that coolant is supplied to the upstream region of the interior shell space of the reactor via the upstream coolant inlet and is removed

- 11 -

from the upstream region at or near the bottom of the upstream region via an upstream coolant outlet. In addition, coolant is supplied to the downstream region of the reactor at or near the top of the downstream region via a downstream
5 coolant inlet, which is fluidly connected to the upstream coolant outlet, and is removed from the downstream region via the downstream coolant outlet.

In accordance with the processes of the present disclosure, coolant is preferably supplied to the interior
10 shell space of the reactor via the upstream coolant inlet at a flow rate that is sufficiently low enough so that the downstream outlet coolant temperature (i.e. the temperature of the coolant as measured at the downstream coolant outlet) exceeds that of the upstream inlet coolant temperature (i.e.
15 the temperature of the coolant as measured at the upstream coolant inlet) by 5 to 30 °C, or 5 to 20 °C. As such, the reactor is operated in a manner where the isothermicity of the coolant side is deliberately compromised by utilizing co-current coolant flow, thereby conversely allowing for the
20 process side to become remarkably isothermal.

In particular, in view of the above, in the present process it is preferred that the coolant is supplied to the interior shell space via an upstream coolant inlet at an upstream inlet coolant temperature and is withdrawn from the
25 interior shell space via a downstream coolant outlet at a downstream outlet coolant temperature, and that said downstream outlet coolant temperature exceeds said upstream inlet coolant temperature by 5°C to 30°C, preferably 5°C to 20°C, most preferably 10°C to 15°C. Preferably, the difference
30 between said downstream outlet coolant temperature and said upstream inlet coolant temperature is at least 5°C, more preferably at least 10°C, most preferably at least 15°C. Further, preferably, the difference between said downstream

- 12 -

outlet coolant temperature and said upstream inlet coolant temperature is at most 30°C, more preferably at most 25°C, more preferably at most 20°C, most preferably at most 15°C.

As will be appreciated by one skilled in the art, suitable coolant flow rates may vary widely depending, at least in part, on the specific configuration of the multitubular fixed-bed reactor (e.g. the length and internal diameter of the tubes within the reactor, the presence of a partition plate), process conditions, the activity level of the ODH catalyst employed, the size and/or shape of the catalyst employed, as well as the particular heat capacity of the coolant. It is within the ability of one skilled in the art to select a suitable coolant flow rate, taking into consideration, for example, the above-mentioned parameters. Suitably, if desired, simulation models can be used to determine the appropriate coolant flow rate needed in order to achieve the desired coolant temperature differential. Reference is made to, for example, A. Soria Lopez, et al., "Parametric Sensitivity of a Fixed Bed Catalytic Reactor", Chemical Engineering Science, Volume 36 (1981), pp. 285-291 for further discussion relating to the effects of temperature variation in a co-current coolant on the operation of a fixed bed reactor.

Suitably, the upstream inlet coolant temperature is typically at least 250° C, or at least 275° C, or at least 300° C, or at least 310° C, or at least 320° C, and typically at most 500° C, or at most 450° C, or at most 425° C, or at most 400° C, or at most 380° C, or from 250° C to 500° C, or from 250° C to 400° C, or from 300° C to 400° C, or from 320° C to 380° C.

Optionally, the heat that is removed from the reactor may be used to heat the feed gas and/or the coolant that is supplied to the reactor. Further, if desired, the removed

- 13 -

heat may also be used for steam generation (or boiler feed water preheat) for use as an energy source, including as steam itself or further transformed into power.

Reference is now made to FIGS. 1 and 2, which are
5 schematic views of reaction systems for the oxidative dehydrogenation of ethane, according to certain embodiments of the present disclosure. It will be clear to the skilled person, that as a schematic diagram these figures do not show all necessary inputs, outputs, recycle streams, etc. that may
10 be present in the reaction system. Furthermore, in the figures, as will be appreciated, elements can be added, exchanged, and/or eliminated so as to provide any number of additional embodiments. In addition, as will be appreciated, the proportion and the relative scale of the elements
15 provided in the figures are intended to illustrate the embodiments of the present disclosure, and should not be taken in a limiting sense.

It should additionally be appreciated that the orientation/configuration shown in FIGS. 1 and 2 are not
20 intended to be limiting or exhaustive of all possible orientations/configurations, but rather are intended to be merely examples provided to illustrate the spirit of the invention. For example, in FIG. 1, the inlet of the reactor is illustrated as being positioned at the top of the reactor
25 with the flow of reactants proceeding downward towards the outlet of the reactor positioned at the bottom; however, it should be understood that the orientation may vary from that depicted. For example, the reactor orientation may be inverted from that shown such that the inlet of the reactor
30 is positioned, for example, at the bottom of the reactor with the flow of reactants proceeding upward towards an outlet positioned at the top of the reactor.

- 14 -

Multitubular fixed-bed reactor (1) comprises reactor inlet (2), reactor shell (3) and a plurality of open-ended reactor tubes (4) positioned substantially parallel to the central longitudinal axis (5) of reactor (1). The upper ends (6) of the reactor tubes (4) are connected to a substantially horizontal upper tube plate (7) and the lower ends (8) of the reactor tubes (4) are connected to a substantially horizontal lower tube plate (9). The upper tube plate (7) and the lower tube plate (9) are supported by the inner wall of reactor (1).

As shown in FIG. 1, reactor tubes (4) contain a catalyst bed (10) comprising an oxidative dehydrogenation catalyst (11). In addition to catalyst bed (10), reactor tubes (4) may optionally further comprise a bed of inert material, such as inert bed (12) comprising inert material (13). Typically, catalyst bed (10) is supported in the reactor tubes (4) by a catalyst support means (not shown) arranged in the lower ends (8) of the reactor tubes (4).

In accordance with the processes of the present disclosure, a feed gas (14) comprising ethane and oxygen is supplied to reactor (1) via one or more inlets, such as reactor inlet (2) which is in fluid communication with the upper ends (6) of the reactor tubes (4). In reactor tubes (4), feed gas (14) contacts oxidative dehydrogenation catalyst (11). Contact of the feed gas in the presence of oxidative dehydrogenation catalyst (11) at appropriate reaction conditions, as described above, converts at least a portion of the ethane to ethylene, water and reaction byproducts, if any. Reactor effluent (15) exits the reactor (1) via one or more outlets, such as reactor outlet (16) which is in fluid communication with the lower ends (8) of the reactor tubes (4).

- 15 -

As shown in FIG. 1, coolant is supplied to interior shell space (17) of reactor (1) via one or more upstream coolant inlets, such as upstream coolant inlet (19), and is removed from interior shell space (17) via one or more downstream coolant outlets, such as downstream coolant outlet (18). Suitably, a cooling apparatus (not shown) may be used to remove heat from the coolant before it is re-supplied to interior shell space (17). Optionally, interior shell space (17) may be provided with baffles (not shown) to guide coolant.

Optionally, as shown in FIG. 2, reactor (1) may comprise perforated partition (20), which divides interior shell space (17) of reactor (1) into two separate regions, upstream region (21) and downstream region (22). Coolant is supplied to upstream region (21) via upstream coolant inlet (19) and is removed from upstream region (21) via upstream coolant outlet (23). Further, coolant is supplied to downstream region (22) via downstream coolant inlet (25), which is fluidly connected to upstream coolant outlet (23) via coolant circuit (24), and is removed from downstream region (22) via downstream coolant outlet (18). Suitably, a cooling apparatus (not shown) may be used to remove heat from the coolant before it is re-supplied to interior shell space (17). Optionally, interior shell space (17) may be provided with baffles (not shown) to guide coolant.

As previously mentioned, coolant is supplied to interior shell space (17) in a flow pattern that is co-current with the flow of the feed gas through the reactor tubes (4). Further, coolant is preferably supplied to interior shell space (17) of reactor (1) at a flow rate that is sufficiently low enough so that the temperature of the coolant as measured at downstream coolant outlet (18) will exceed the temperature

- 16 -

of the coolant as measured at upstream coolant inlet (19) by 5 to 30 °C.

The present invention is also applicable to a process for oxidative dehydrogenation of alkanes having a higher carbon number than ethane, in particular alkanes having a
5 carbon number of from 3 to 6 carbon atoms, including propane, butane, pentane and hexane, more specifically propane and butane, most specifically propane.

The invention is further illustrated by the following
10 Examples.

Examples

In the present Examples, a process for the oxidative dehydrogenation (ODH) of ethane to ethylene is carried out in a multitubular fixed-bed reactor comprising a reactor inlet,
15 an interior shell space, and a plurality of reactor tubes, wherein the reactor tubes comprise a catalyst bed that comprises an oxidative dehydrogenation catalyst. The length of each tube is 6 metres. The inner diameter of each tube is 0.75 inch (1.91 cm).

20 A feed gas comprising ethane and oxygen is supplied to the reactor inlet. The temperature of the feed gas at said inlet is 160 °C. The ethane and oxygen are allowed to react in the presence of the above-mentioned catalyst to yield a reactor effluent comprising ethylene. Further, a molten-salt
25 coolant is supplied to the interior shell space of the reactor in a flow pattern that is co-current with the flow of the feed gas through the reactor tubes. Furthermore, the above-mentioned coolant is supplied to the interior shell space via an upstream coolant inlet at an upstream inlet
30 coolant temperature and is withdrawn from the interior shell space via a downstream coolant outlet at a downstream outlet coolant temperature. A set-up for performing the present Examples is shown in Figure 1.

- 17 -

In the upstream part of the reactor, the temperature of the process stream comprising reactants and/or products (hereinafter referred to as "process temperature") increases as a consequence of the exothermic ethane ODH reaction taking place. Said process temperature equals the catalyst temperature. Moving along the reactor length starting from the upstream reactor inlet, said process temperature increases to a certain maximum (peak) temperature, after which the process temperature would decrease because the ethane concentration decreases resulting in less heat production. A relatively high peak temperature for the process stream, as compared to the average process stream temperature, is disadvantageous in that this increases the risk of a reactor runaway.

In the present Examples, the effect of the difference between the downstream outlet coolant temperature and the upstream inlet coolant temperature on the difference between peak process temperature and average process temperature is assessed. Generally, the greater the latter difference the greater the likelihood of a reactor runaway is. The temperature data (in °C) in relation to a variety of cases are shown in Table 1 below.

Further, in the present Examples, the space-time-yield (STY) is set at 700 g of ethylene per liter of catalyst per hour. Further, the ethane conversion is set at 55% and the ethylene selectivity at 91%. Said STY and ethane conversion are kept constant at said levels by adjustment of catalyst activity. The total and partial pressures of ethane (C_2H_6) and oxygen (O_2) at the upstream reactor inlet are kept constant: $P_{total} = 3 \text{ bar}$; $p_{C_2H_6} = 2.1 \text{ bar}$; $p_{O_2} = 0.9 \text{ bar}$. The gas hourly space velocity (GHSV) is 1950 hr^{-1} .

Table 1

	Example 1	Example 2	Example 3
T_{Co}	355	360	370
T_{Ci}	355	355	355
$\Delta[T_{Co}-T_{Ci}]$	0	5	15
$\Delta[T_{Pp}-T_{Pa}]$	28	17	2

T_{Co} = outlet coolant temperature; T_{Ci} = inlet coolant temperature

T_{Pp} = peak process temperature; T_{Pa} = average process temperature

5 Surprisingly, it appears from the results in Table 1
above that by ensuring that the downstream outlet coolant
temperature exceeds the upstream inlet coolant temperature by
5°C or more, the difference between peak process temperature
and average process temperature can advantageously be kept
10 relatively small, thereby preventing or minimizing the above-
mentioned risk of a reactor runaway. By letting the
downstream outlet coolant temperature exceed the upstream
inlet coolant temperature by only 5 °C (Example 2), already a
substantial reduction of the difference between peak process
15 temperature and average process temperature is advantageously
achieved, from 28 °C (Example 1) to 17 °C (Example 2). By
further increasing the difference between the downstream
outlet coolant temperature and the upstream inlet coolant
temperature to only 15 °C (Example 3), the difference between
20 peak process temperature and average process temperature
advantageously approaches zero (2 °C in Example 3).

- 19 -

C L A I M S

1. A process for the oxidative dehydrogenation of ethane to ethylene comprising:
 - providing a multitubular fixed-bed reactor comprising a reactor inlet, an interior shell space, and a plurality of reactor tubes, wherein the plurality of reactor tubes comprise a catalyst bed that comprises an oxidative
 - 5 dehydrogenation catalyst;
 - supplying a feed gas comprising ethane and oxygen to the reactor inlet and allowing the ethane and oxygen to react in the presence of the oxidative dehydrogenation catalyst to yield a reactor effluent comprising ethylene; and
 - 10 supplying a coolant to the interior shell space of the multitubular fixed-bed reactor in a flow pattern that is co-current with the flow of the feed gas through the plurality of reactor tubes.
2. The process of claim 1, wherein the coolant is supplied to the interior shell space via an upstream coolant inlet at an upstream inlet coolant temperature of from 250°C to 500°C.
3. The process of claim 1, wherein the coolant is supplied to the interior shell space via an upstream coolant inlet at an upstream inlet coolant temperature of from 250°C to 400°C.
4. The process of claim 1, wherein the coolant is supplied to the interior shell space via an upstream coolant inlet at an upstream inlet coolant temperature of from 300°C to 400°C.
5. The process of any one of claims 1-4, wherein the coolant is supplied to the interior shell space via an upstream coolant inlet at an upstream inlet coolant temperature and is withdrawn from the interior shell space via a downstream coolant outlet at a downstream outlet coolant temperature, and wherein the downstream outlet coolant temperature exceeds the upstream inlet coolant temperature by 5°C to 30°C.

- 20 -

6. The process of any one of claims 1-4, wherein the coolant is supplied to the interior shell space via an upstream coolant inlet at an upstream inlet coolant temperature and is withdrawn from the interior shell space via a downstream coolant outlet at a downstream outlet coolant temperature, and wherein the downstream outlet coolant temperature exceeds the upstream inlet coolant temperature by 5°C to 20°C.

7. The process of any one of claims 1-6, wherein the multitubular fixed-bed reactor further comprises a perforated partition that divides the interior shell space into an upstream region and a downstream region.

8. The process of claim 7, wherein the upstream region is from 10% to 20% of the length of the reactor tubes.

9. The process of claim 7 or claim 8, wherein the coolant is supplied to the upstream region via the upstream coolant inlet, is withdrawn from the upstream region via an upstream coolant outlet, is supplied to the downstream region via a downstream coolant inlet that is in fluid communication with the upstream coolant outlet, and is withdrawn from the downstream region via the downstream coolant outlet.

10. The process of any one of claims 1-9, wherein the oxidative dehydrogenation catalyst in the catalyst bed has the following formula:

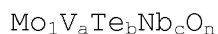

wherein:

a, b, c and n represent the ratio of the molar amount of the element in question to the molar amount of molybdenum;

5 a is from 0.01 to 1;

b is 0 or from >0 to 1;

c is from >0 to 1; and

n is a number which is determined by the valency and frequency of elements other than oxygen.

1/2

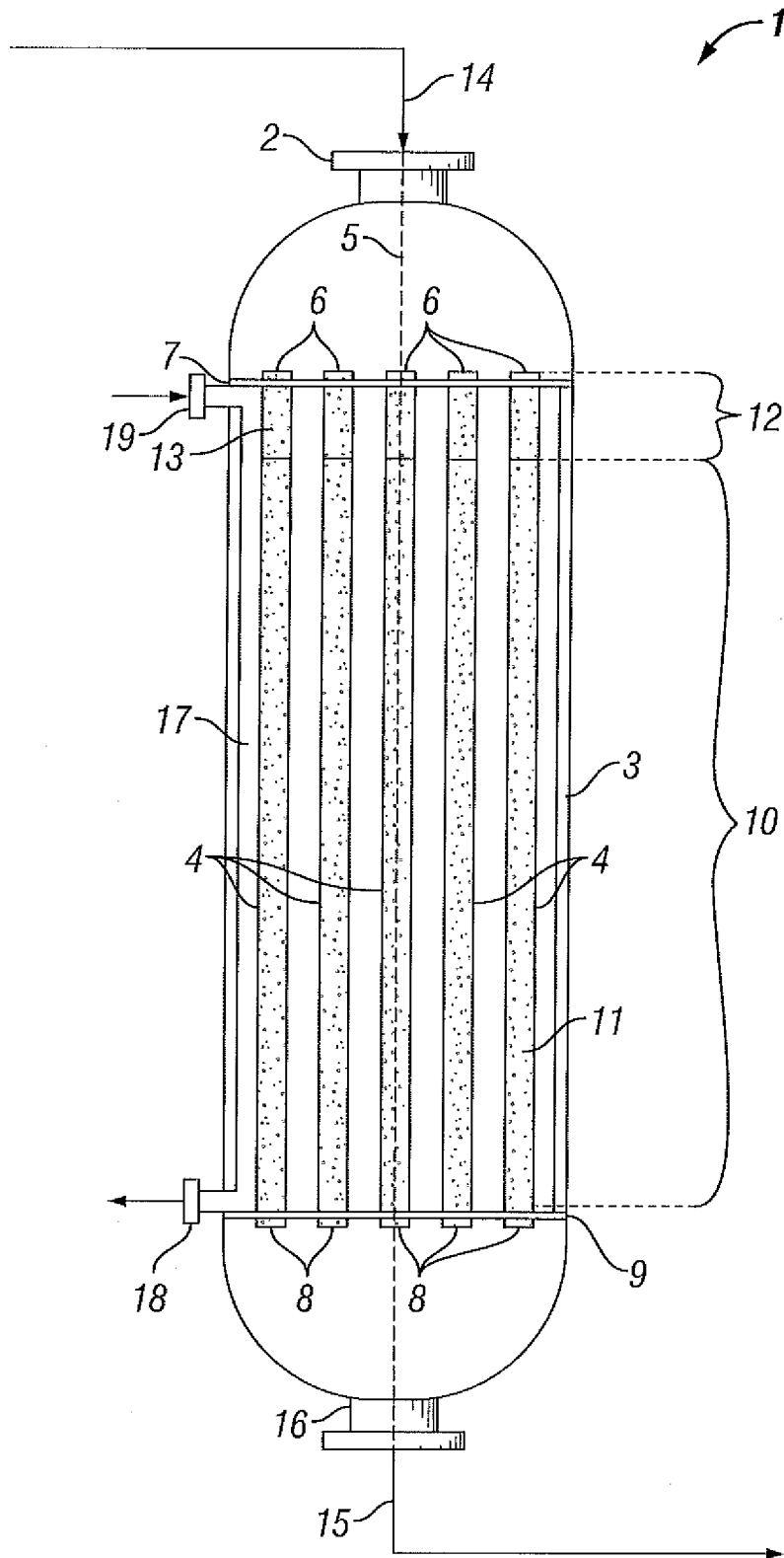

FIG. 1

2/2

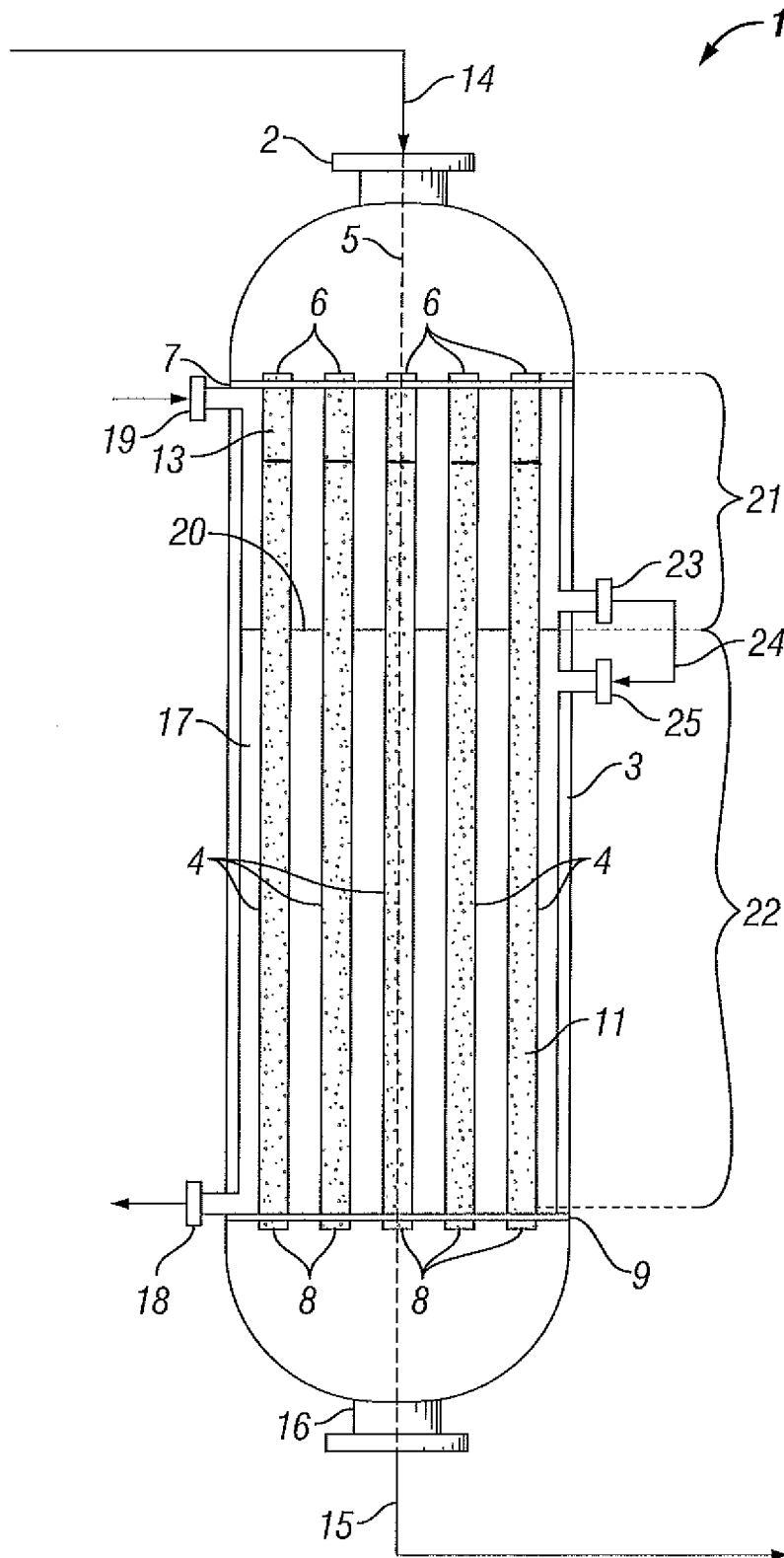

FIG. 2

INTERNATIONAL SEARCH REPORT

International application No
PCT/EP2017/068615

A. CLASSIFICATION OF SUBJECT MATTER
INV. C07C5/48 C07C11/04 B01J8/06
ADD.
According to International Patent Classification (IPC) or to both national classification and IPC

B. FIELDS SEARCHED
Minimum documentation searched (classification system followed by classification symbols)
C07C B01J
Documentation searched other than minimum documentation to the extent that such documents are included in the fields searched

Electronic data base consulted during the international search (name of data base and, where practicable, search terms used)
EPO-Internal, WPI Data

C. DOCUMENTS CONSIDERED TO BE RELEVANT		
Category*	Citation of document, with indication, where appropriate, of the relevant passages	Relevant to claim No.
X	EP 2 716 622 A1 (LINDE AG [DE]) 9 April 2014 (2014-04-09)	1-4,10
Y	claims	7-9
A	paragraphs [0030], [0034]; figure 4; example 1	5,6
Y	----- WO 01/85333 A2 (SAUDI BASIC IND CORP [SA]; ADRIS ALAA ELDIN MOSTAFA [SA]; AL SHEREHY F) 15 November 2001 (2001-11-15) page 10, lines 1-18; figure 4 page 15, line 011 -----	7-9

Further documents are listed in the continuation of Box C.

See patent family annex.

* Special categories of cited documents :

- "A" document defining the general state of the art which is not considered to be of particular relevance
- "E" earlier application or patent but published on or after the international filing date
- "L" document which may throw doubts on priority claim(s) or which is cited to establish the publication date of another citation or other special reason (as specified)
- "O" document referring to an oral disclosure, use, exhibition or other means
- "P" document published prior to the international filing date but later than the priority date claimed

- "T" later document published after the international filing date or priority date and not in conflict with the application but cited to understand the principle or theory underlying the invention
- "X" document of particular relevance; the claimed invention cannot be considered novel or cannot be considered to involve an inventive step when the document is taken alone
- "Y" document of particular relevance; the claimed invention cannot be considered to involve an inventive step when the document is combined with one or more other such documents, such combination being obvious to a person skilled in the art
- "&" document member of the same patent family

Date of the actual completion of the international search 9 October 2017	Date of mailing of the international search report 16/10/2017
Name and mailing address of the ISA/ European Patent Office, P.B. 5818 Patentlaan 2 NL - 2280 HV Rijswijk Tel. (+31-70) 340-2040, Fax: (+31-70) 340-3016	Authorized officer Kardinal, Siegmar

INTERNATIONAL SEARCH REPORT

Information on patent family members

International application No

PCT/EP2017/068615

Patent document cited in search report	Publication date	Patent family member(s)	Publication date
EP 2716622	A1	09-04-2014	NONE

WO 0185333	A2	15-11-2001	AT 468914 T 15-06-2010
		AU 5807901 A	20-11-2001
		EP 1284815 A2	26-02-2003
		EP 1541226 A2	15-06-2005
		ES 2345535 T3	27-09-2010
		GC 0000225 A	29-03-2006
		KR 20030022116 A	15-03-2003
		US 6977064 B1	20-12-2005
		US 2006003402 A1	05-01-2006
		WO 0185333 A2	15-11-2001
