

No. 754,594.

PATENTED MAR. 15, 1904.

T. L. McKEEN.
FRICTION DRAFT GEAR FOR RAILWAY CARS.

APPLICATION FILED AUG. 28, 1903.

NO MODEL.

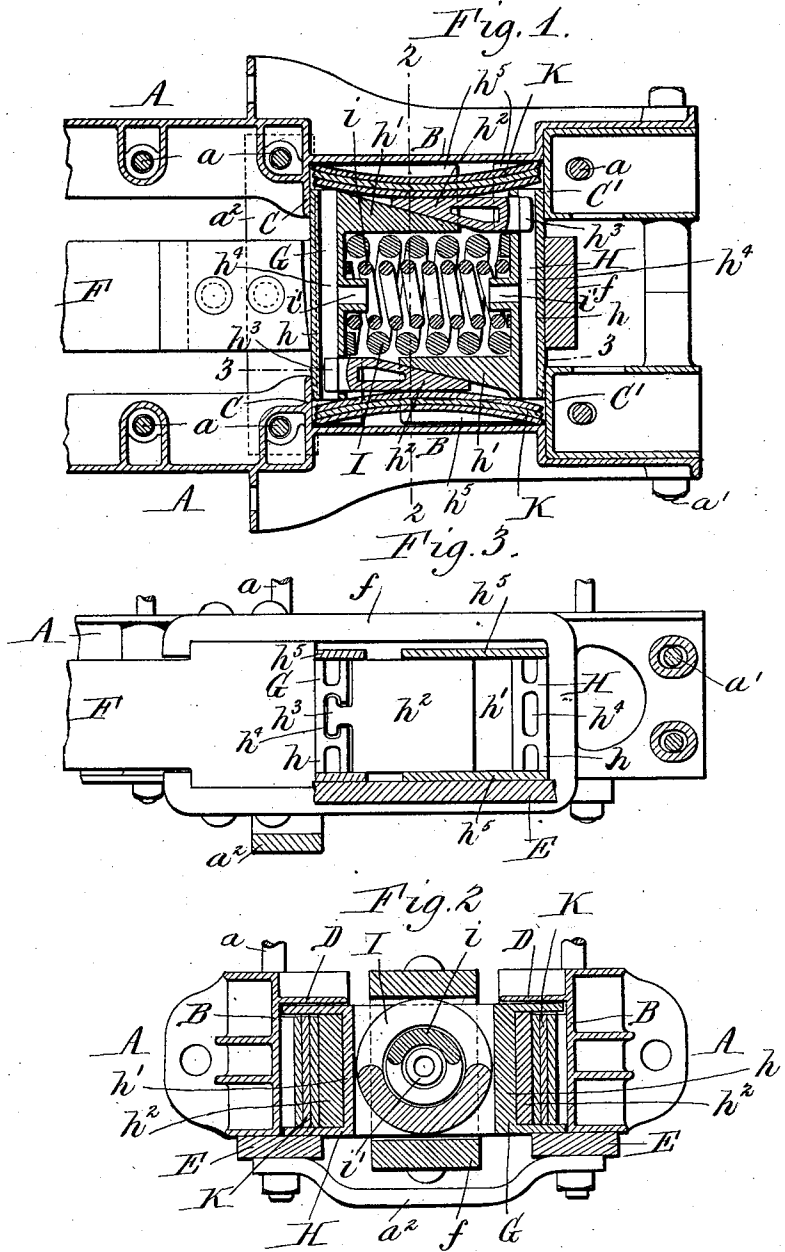

Witnesses:
J. M. Snyder, Jr.
J. W. Pinner.

Thos. L. McKeen Inventor.
By Wilhelm St. Pomeroy
Attorneys.

UNITED STATES PATENT OFFICE.

THOMAS L. McKEEN, OF EASTON, PENNSYLVANIA.

FRICION DRAFT-GEAR FOR RAILWAY-CARS.

SPECIFICATION forming part of Letters Patent No. 754,594, dated March 15, 1904.

Application filed August 28, 1903. Serial No. 171,075. (No model.)

To all whom it may concern:

Be it known that I, THOMAS L. McKEEN, a citizen of the United States, residing at Easton, in the county of Northampton and State of Pennsylvania, have invented new and useful Improvements in Friction Draft-Gear for Railway-Cars, of which the following is a specification.

This invention relates to a friction draft and buffing gear for railway-cars comprising followers movable with the draw-bar and springs which are compressed or strained by parts carried by the followers and caused to move laterally by the longitudinal movements of the draw-bar in drawing and buffing.

The object of the invention is to provide a strong, compact, and practical friction draft-gear of simple and inexpensive construction which has great capacity in buffing and starting cars.

In the accompanying drawings, Figure 1 is a fragmentary horizontal section, partly in plan, of a draft and buffing gear embodying the invention. Fig. 2 is a transverse vertical sectional elevation thereof in line 2 2, Fig. 1. Fig. 3 is a sectional elevation thereof in line 3 3, Fig. 1.

Like letters of reference refer to like parts in the several figures.

A represents oppositely-arranged supporting and guiding members which are constructed and secured to the car in proper relation in any suitable manner. In the construction shown the supporting members are in the form of draft-arms secured beneath the car-sills (not shown) by suitable vertical bolts a , passing through bolt-holes in the draft-arms. The latter are connected and held from spreading by a transverse bolt a' , passing through their rear portions, and a cross-tie bar a'' , which is arranged below the draft-arms and is connected to the latter by the vertical securing-bolts. Each draft-arm is provided between its ends with a longitudinal vertical side plate or portion B and vertical front and rear stop faces or shoulders C C', which are suitably braced by longitudinal strengthening ribs or flanges on the draft-arms. Between the vertical front and rear stop faces or shoulders the draft-arm is provided near its top

with an inwardly-projecting guide rib or flange D.

E represents horizontal carrying irons or bars which are secured longitudinally beneath the draft-arms by the vertical securing-bolts for the latter and project inwardly beyond the vertical side plates of the draft-arms and constitute supports for the movable followers.

F represents the rear portion of the draw-bar or coupler-stem, which is preferably provided with the usual strap or yoke f , extending rearwardly therefrom.

G and H represent, respectively, oppositely-arranged front and rear followers which are movable horizontally forwardly and rearwardly between the draft-arms, being supported and guided between the horizontal carrying-irons and the inwardly-projecting horizontal guide-flanges of the draft-arms. The followers pass loosely through the draw-bar yoke, the front follower bearing against the rear end of the draw-bar, while the rear follower bears against the rear end of the yoke.

In their normal position the front and rear followers bear, respectively, against the front and rear stop-faces C C' on the draft-arms. The two followers are alike and interchangeable.

Each follower consists of a transverse vertical plate or portion h , having at one side thereof a fixed wing or wedge h' and at the other side a laterally-movable wing or wedge h'' , both of which extend toward the other follower. The fixed and movable wings of one follower respectively overlap and bear with sliding contact against the movable and fixed wings of the other follower, as shown, and the contacting faces of both the fixed and movable wings are inclined. In the construction shown in the drawings the movable wing of each follower is provided with a headed shank h^3 , which slides laterally in an undercut groove or slot h^4 in the transverse plate of its follower. The movable wing can be slidably connected with its follower in any other suitable manner.

When the followers are moved toward each other, the engagement of the inclined faces of the fixed and movable wings act to spread or separate laterally the two loose wings. At opposite sides the followers are preferably provided with horizontal flanges h^5 , which

project outwardly from the upper and lower ends of the followers.

I *i* represent outer and inner coil draft and buffing springs arranged longitudinally between the followers and confined between the wings of the followers. The latter are preferably provided with central bosses *i'*, which prevent the displacement of the springs.

Instead of the draw-bar yoke the followers can be connected by the ordinary draw-bar bolt or stem passing through the coil-springs and through central holes in the followers.

K represents flat spring-plates or leaf-springs, a set of which is arranged between the vertical side plate or portion of each draft-arm and the outer face of the adjacent movable follower-wing. The spring-plates are bowed inwardly, and the central portion of the inner plate of each set bears against the straight or flat outer face of the adjacent movable wing. The spring-plates are confined vertically between the outwardly-projecting horizontal flanges of the wings of the followers and are adapted to abut at their ends against the vertical front and rear stop-faces of the draft-arms, which stop-faces are separated a distance sufficient to permit the spring-plates to be straightened out more or less.

When the draw-bar or coupler-stem is pulled forwardly in starting or drawing the car, the front follower is held stationary against its stop-faces and the rear follower is moved forwardly, causing the beveled or inclined faces of its fixed and movable wings to slide on the inclined faces of the movable and fixed wings, respectively, of the other follower. As the transverse follower-plates and the fixed wings are held from lateral movement by the draft-arms, the movable wings are forced or spread apart, thereby straining or straightening the spring-plates or leaf-springs of both sets and producing friction between the fixed and movable wings of the followers and between the movable wings and spring-plates. The followers at the same time compress the coil draft and buffing springs. In buffing the front follower is moved rearwardly by the engagement therewith of the rear end of the draw-bar, while the rear follower is held stationary by the rear stop-faces of the draft-arms. The rearward movement of the front follower acts to spread or separate the movable wings of the two followers in the same manner as the forward movement of the rear follower, thereby straining the spring-plates or leaf-springs and producing friction between the same and the movable wings and between the fixed and movable wings of the followers. The coil-springs are compressed by the movement of either follower and return the parts to the initial position. The movable wings of the followers bear at all times on the spring-plates at or near their central portion, thus insuring the best spring action of the plates and caus-

ing the resistance of the spring-plates against the movement of the followers to increase from the commencement of the movement of the latter.

The draft-arms shown in the drawings can be replaced by ordinary cheek-plates or supporting and guide members constructed and secured in any suitable manner.

I claim as my invention—

1. The combination of supporting members, a draw-bar, two followers each of which is movable in one direction with the draw-bar, stops for limiting the movements of said followers in the opposite direction, each of said followers having a fixed wing, and a laterally-movable wing which is moved laterally by the longitudinal movement of the fixed wing of the other follower, and springs which are strained by the lateral movement of said movable wings, substantially as set forth.

2. The combination of supporting members, a draw-bar, two followers each of which is movable in one direction with said draw-bar, stops for limiting the movement of said followers in the opposite direction, each of said followers having a fixed wing provided with an inclined face and a laterally-movable wing engaging the inclined face of the fixed wing of the other follower, and springs which are strained by said laterally-movable wings, substantially as set forth.

3. The combination of supporting members, a draw-bar, two followers each of which is movable in one direction with said draw-bar, stops for limiting the movement of said followers in the opposite direction, each of said followers having a fixed wing, and a laterally-movable wing provided with an inclined face engaging the fixed wing of the other follower, and springs which are strained by said laterally-movable wings, substantially as set forth.

4. The combination of supporting members, a draw-bar, two followers, each of which is movable in one direction with the draw-bar, stops for limiting the movement of said followers in the opposite direction, each of said followers having a fixed wing provided with an outer inclined face, and a laterally-movable wing which engages the inclined face of the fixed wing of the other follower, and springs arranged between said movable wings and said supporting members, substantially as set forth.

5. The combination of supporting members, a draw-bar, two followers, each of which is movable in one direction with the draw-bar, stops for limiting the movement of said followers in the opposite direction, each of said followers having a fixed wing provided with an outer inclined face, and a laterally-movable wing which engages the inclined face of the fixed wing of the other follower, and spring-plates arranged between said movable wings and said supporting members, substantially as set forth.

6. The combination of supporting members,
a draw-bar, two followers, each of which is
movable in one direction with the draw-bar,
stops for limiting the movement of said fol-
5 lowers in the opposite direction, each of said
followers having a fixed wing provided with
an outer inclined face, a laterally-movable
wing which engages the inclined face of the
fixed wing of the other follower, spring-plates

arranged between said movable wings and said 10
supporting members, and a coil-spring be-
tween said followers, substantially as set forth.

Witness my hand this 5th day of August,
1903.

THOMAS L. McKEEN.

Witnesses:

JNO. J. BONNER,
CHAS. W. PARKER.