

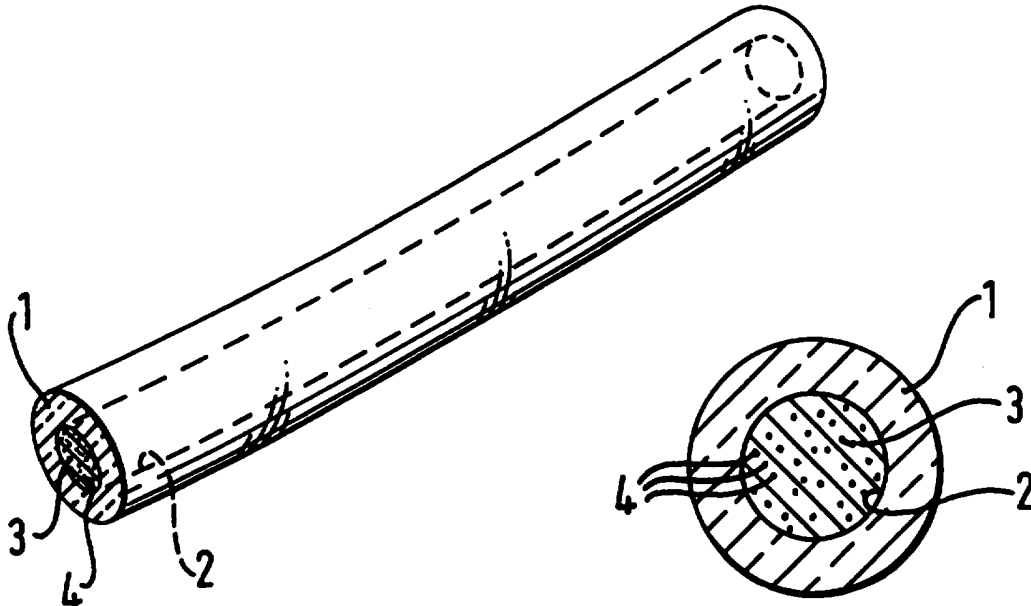

## INTERNATIONAL APPLICATION PUBLISHED UNDER THE PATENT COOPERATION TREATY (PCT)

<p>(51) International Patent Classification <sup>6</sup> : H01S 3/19, 3/06, G02B 6/20, G02F 1/35</p>	<p>A1</p>	<p>(11) International Publication Number: <b>WO 96/10282</b> (43) International Publication Date: 4 April 1996 (04.04.96)</p>
<p>(21) International Application Number: PCT/GB95/02322 (22) International Filing Date: 29 September 1995 (29.09.95) (30) Priority Data: 94307113.4 29 September 1994 (29.09.94) EP (34) Countries for which the regional or international application was filed: GB et al. (71) Applicant (for all designated States except US): BRITISH TELECOMMUNICATIONS PUBLIC LIMITED COMPANY [GB/GB]; 81 Newgate Street, London EC1A 7AJ (GB). (72) Inventor; and (75) Inventor/Applicant (for US only): BURT, Michael, Graham [GB/GB]; Glebe Corner, Kingston Road, Woodbridge, Suffolk IP12 4AY (GB). (74) Agents: WOODWARD, John, Calvin et al.; Venner, Shipley &amp; Co., 20 Little Britain, London EC1A 7DH (GB).</p>		<p>(81) Designated States: CA, JP, KR, US, European patent (AT, BE, CH, DE, DK, ES, FR, GB, GR, IE, IT, LU, MC, NL, PT, SE).  <b>Published</b> <i>With international search report.</i></p>

(54) Title: OPTICAL FIBRE WITH QUANTUM DOTS



## (57) Abstract

An optical fibre comprises a tubular glass cladding (1) with a central opening (2), filled with a colloidal solution of quantum dots (4) in a support medium (3). The quantum dots may be caused to produce luminescence in response to input optical radiation, for example to produce optical amplification or laser radiation. A waveguide with an active medium comprising colloidal quantum dots is claimed.

**FOR THE PURPOSES OF INFORMATION ONLY**

Codes used to identify States party to the PCT on the front pages of pamphlets publishing international applications under the PCT.

AT	Austria	GB	United Kingdom	MR	Mauritania
AU	Australia	GE	Georgia	MW	Malawi
BB	Barbados	GN	Guinea	NE	Niger
BE	Belgium	GR	Greece	NL	Netherlands
BF	Burkina Faso	HU	Hungary	NO	Norway
BG	Bulgaria	IE	Ireland	NZ	New Zealand
BJ	Benin	IT	Italy	PL	Poland
BR	Brazil	JP	Japan	PT	Portugal
BY	Belarus	KE	Kenya	RO	Romania
CA	Canada	KG	Kyrgystan	RU	Russian Federation
CF	Central African Republic	KP	Democratic People's Republic of Korea	SD	Sudan
CG	Congo	KR	Republic of Korea	SE	Sweden
CH	Switzerland	KZ	Kazakhstan	SI	Slovenia
CI	Côte d'Ivoire	LI	Liechtenstein	SK	Slovakia
CM	Cameroon	LK	Sri Lanka	SN	Senegal
CN	China	LU	Luxembourg	TD	Chad
CS	Czechoslovakia	LV	Latvia	TG	Togo
CZ	Czech Republic	MC	Monaco	TJ	Tajikistan
DE	Germany	MD	Republic of Moldova	TT	Trinidad and Tobago
DK	Denmark	MG	Madagascar	UA	Ukraine
ES	Spain	ML	Mali	US	United States of America
FI	Finland	MN	Mongolia	UZ	Uzbekistan
FR	France			VN	Viet Nam
GA	Gabon				

## OPTICAL FIBRE WITH QUANTUM DOTS

This invention relates to an optical fibre and has particular but not exclusive application to use as an optical amplifier.

5

### Background of the Invention

It is known that erbium doped fibres can be used as optical amplifiers. However, they suffer from a number of disadvantages. For example, a long length of fibre is required in order to achieve a significant level of amplification, e.g. 10m. Also, erbium is a toxic substance so manufacture of the doped fibre is complex and requires strict pollution control measures.

Recently, it has been shown that very small particles, fabricated on the nanometre scale, give rise to specific optical effects, such as electroluminescence. A review is given in Colloidal Semi-conductor Q-Particles; Chemistry in the Transition Region Between Solid State and Molecules, M. Weller: Angew, Chem. Int. Ed. Engl. 1993, 32,41-53. These nanometre scale particles are known as quantum dots.

A laser making use of quantum dots is described in US Patent No. 5 260 957. In this arrangement, a host material such as PMMA contains quantum dots. The laser may be in the form of a channel waveguide device, the host material being arranged in a cavity formed in a channel machined in a substrate, the substrate having a lower refractive index than the host. The laser is pumped by an external light source in order to provide a laser output. The use of polymeric material is said to be advantageous.

An optical fibre with non-linear optical characteristics is known from JP-A-4-195028, in which the interior of a tubular glass sheath is coated with materials that, on subsequent heating, form particulate material disposed in a glass core of the fibre.

30

- 2 -

The present invention is concerned with the production of an optical fibre with improved amplification or wavelength conversion characteristics.

In accordance with the present invention, there is provided an optical fibre  
5 with a colloid of quantum dots therein.

The fibre may include a core and a cladding, with the colloid of quantum dots forming at least part of the core.

10 The colloid of quantum dots may include a non-vitreous support medium in which the dots are dispersed, e.g. dichlorobenzene, toluene, benzene, nitrobenzene, pyridene or carbontetrachloride.

The dot density in the medium and the diameter distribution for the dots are  
15 selected depending on the application of the fibre. Similarly, the materials from which the dots are made are selected depending on the intended use. For example, when used as an optical amplifier, the quantum dots may comprise lead sulphide (PbS) with a diameter range of 5-10 nm.

20 The fibre according to the invention has particular application as an amplifier, when pumped by an external source, so that input light, e.g. light pulses, can be amplified. The arrangement may be similar to that used for a conventional erbium doped fibre, but with the advantage that the amplification is more efficient and so a much shorter length of fibre can be used. The fibre however  
25 has other uses, e.g. as a wavelength converter.

### **Brief Description of the Drawings**

In order that the invention may be more fully understood, an embodiment thereof and a method of making the same will now be described by way of  
30 example with reference to the accompanying drawings, in which:

Figure 1 is a schematic perspective view of an optical fibre in accordance with the invention;

- 3 -

Figure 2 is a transverse cross section of the fibre shown in Figure 1;  
Figure 3 shows a method of making the fibre shown in Figure 1; and  
Figure 4 illustrates the fibre, used in an optical amplifier.

#### Detailed Description

5 Referring to Figure 1, this shows an example of optical fibre in accordance  
with the invention which consists of a tubular glass sheath 1 that has an  
elongated central opening 2 running the length thereof. Such a hollow fibre  
can be made and filled with a liquid in the manner demonstrated by Kashyap  
and Finlayson in Optics Letters 17 pp 405-407 (1992). The central opening 2  
10 is filled with a colloid of quantum dots, namely a support medium 3 that  
contains quantum dots 4. This can be seen clearly from Figure 2.

The colloid of quantum dots (3,4) forms the core of the fibre and the glass  
sheath 1 forms its cladding. The refractive index of the support medium 3 is  
15 selected to be somewhat greater than the refractive index of the glass sheath 1  
so that the refractive index difference  $\Delta n$  will cause light incident at one end  
of the fibre to be propagated along the length of the core, in a manner well  
known per se for optical fibres. Thus, light transmitted along the fibre is  
incident on the quantum dots 4 held in the support medium 3.

20 The quantum dots 4 are selected to produce photoluminescence. An  
appropriate selection is to use a material that luminesces efficiently in the bulk  
e.g. a direct gap semiconductor or insulator such as a III-V, II-VI or I-VII  
material or some alloy of these. However, other material should not be  
25 excluded, because selection rules that prevent a material luminescing efficiently  
in the bulk are relaxed to some extent in quantum dots. Also the surface  
treatment of the quantum dots may introduce new electronic transitions that  
may lead to efficient luminescence that is not related to the bulk electronic  
structure.

30 Suitable materials for the support medium are liquids with a refractive index  
larger than that for the glass of which the fibre is composed. Examples of

- 4 -

such liquids are toluene, benzene and nitrobenzene.

As described by Weller, hitherto, much research has been carried out on colloidal samples for CdS, CdSe, PbSe and PbS, although reports on the synthesis of other particles include ZnS, ZnO, TiO<sub>2</sub>, AgI, AgBr, HgI<sub>2</sub>, ZnTe, CdTe, In<sub>2</sub>S<sub>3</sub>, In<sub>2</sub>Se<sub>3</sub>, Cd<sub>3</sub>P<sub>2</sub>, Cd<sub>3</sub>As<sub>2</sub> and also GaAs. The sulphides, selenides, tellurides, and phosphides can be prepared by precipitation by H<sub>2</sub>S, H<sub>2</sub>Se, H<sub>2</sub>Te or PH<sub>3</sub> or their alkaline metal salts, from a solution containing the metal ion. Either AsH<sub>3</sub> or As(CH<sub>3</sub>)<sub>3</sub> is used for the preparation of arsenides. The oxides are prepared, for example by the hydrolysis of the alkoxy compounds. Stable colloidal solutions are obtained by the addition of stabilisers (tensides, organic or inorganic polymers).

A much used method for the preparation of quantum dots is the precipitation in the presence of sodium polyphosphate as a stabiliser. The polyphosphate is well suited for the stabilisation of quantum dots, because the chain is strongly bound by metal ions to the particle surface. It causes electrostatic repulsion between particles because of its charge and also keeps them apart sterically because of its chain length. By means of the methods described by Weller it is possible to grow a colloidal solution containing for example CdSe particles of average diameter 1.3-2nm.

A wide range of quantum dot diameters may be used. For example, quantum dots within a diameter range of 1-50nm may produce useful results. Dots with a smaller diameter will produce more pronounced fluorescence so a range of 1-20 nm may be preferred.

As shown in Figure 3, the colloidal solution may be caused to enter the tubular glass sheath 1 by capillary action. One end of the sheath 1 is inserted into a reservoir 5 containing the colloidal material 3, 4 which then fills the central opening 2 of the sheath by capillary action. If necessary, negative pressure can be applied to the other end of the sheath to aid the filling

- 5 -

process. Positive pressure may be applied to the surface of the colloidal material in the reservoir 5.

Figure 4 shows an example of the fibre according to the invention in an optical amplifier. One end of the fibre 1 is spliced at region 6 to a  
5 conventional silica optical fibre 7 which itself is fused to a further fibre 8 in a coupling region 9. Optical signals from a source 10 are directed into the fibre 1. Additionally, the fibre is pumped by, for example, a semiconductor laser 11, in order to promote an electron from one of the low energy states  
10 (normally occupied in the absence of the pump or signal beams) in the quantum dot into one of the high energy states (normally unoccupied in the absence of the pump or signal beams). The electron can then amplify a light signal from the source 10 by making a transition back from one of the high energy states to one of the low energy states and thereby emitting a photon,  
15 provided the energy lost by the electron in making the transition matches the energy of the photons in the signal beam.

The invention has the advantage that the amplification efficiency of the fibre, as shown in Figure 4, is much greater than that of a conventional erbium  
20 doped fibre so that the length of fibre needed to achieve the appropriate amplification level is significantly reduced. Also, the power levels from the laser 11 may be reduced significantly. Furthermore, the materials used are less toxic which greatly simplifies manufacture.

25 A great advantage of a quantum dot amplifier is the ease with which it is possible to engineer the gain spectrum so that it is reasonably flat over the entire window of the fibre thereby allowing all wavelengths in a wave division multiplex transmission system to benefit equally from amplification. This can be achieved by ensuring that there is a suitable spread in the sizes of  
30 the quantum dots. If this cannot be done in one preparation, it can be achieved by mixing quantum dots from different preparations containing quantum dots of different mean sizes.

- 6 -

Whilst the arrangement of Figure 4 produces amplification, it will be appreciated that by an appropriate choice of the quantum dots, wavelength conversion can also be achieved. In order to achieve this, the sources 10 and 11 may be selected to stimulate different wavelength transitions associated with the quantum dots. The source 10 may be modulated at a given bit rate, whereas the source 11 acts as a target wavelength, with the result that the optical radiation from the source 11 becomes modulated in the fibre at the bit rate of the source 10, thereby effecting wavelength conversion.

The manufacture of a specific example of an optical fibre for use as an amplifier will now be described.

#### Example

A hollow preform of sodalime glass was drawn into an elongate sheath with an inner diameter of  $5\mu\text{m}$  for its central opening and an outer diameter of  $125\mu\text{m}$ , and cut to a length of 15cm. The sheath had a refractive index of 1.45. The central opening was filled with a colloidal solution of quantum dots of PbS material with a mean diameter of 5-10nm in a support medium of toluene. The filling was achieved by capillary action and negative pressure, as previously described. The ends of the central opening were left open, as the colloidal solution is held in place by capillary action. However, the ends can be filled with an optically transparent plugging material, if required. The mean concentration of the quantum dots in the support medium was approximately 1% by volume. The colloidal solution containing the quantum dots exhibited a refractive index of 1.50. The quantum dots exhibited band gaps over a range of 0.8 - 1.0 eV as a function of diameter, which permitted broadband luminescence over a range 1.3 - 1.5  $\mu\text{m}$  for light fed into the fibre, when pumped at a wavelength of  $1.06\mu\text{m}$  so as to provide broadband amplification in the two wavelength ranges often used for optical telecommunications.

The resulting fibre tends to support a single transmission mode, but if the



- 7 -

diameter of the central opening is increased, multi-mode operation may be achieved.

The PbS quantum dots were formed by precipitation from an aqueous  
5 solution of a soluble lead salt e.g.  $\text{Pb}(\text{NO}_3)_2$  or  $\text{Pb}(\text{OCOCH}_3)_2$ , using  $\text{H}_2\text{S}$  as the precipitating agent, in the presence of sodium polyphosphate as a stabiliser. The resulting quantum dots were then dried so as to form a powder which was then dispersed in toluene in order to produce the colloidal solution to be used as the filler material for the glass sheath.

10

In order to aid luminescence, it is desirable to saturate the bonds which hang free at the surface of the quantum dots. This can be done by arresting the growth of the dots by adding  $\text{Pb}(\text{OH})_2$  so that the bonds which hang free are saturated with hydroxyl radicals. Alternatively, a so called "hard boiled egg"  
15 structure can be formed in which another semiconductor material is grown on the surface of the quantum dots. For example, for PbS dots, the yellow of the egg is PbS and the white may be a layer of CdS grown subsequently. Alternatively "eggs" with a yellow of PbSe and a white of CdSe can be formed. An example of this type of structure has been reported by A. Mews  
20 et al, Journal of Physical Chemistry (1994) 98, p934.

Other modifications fall within the scope of the invention. For example, the cladding material may not have its opening disposed centrally. Furthermore, the cladding may surround a solid core having a refractive index greater than  
25 that of the cladding, the core having an opening therein that receives the colloidal solution of quantum dots. This would reduce the restriction on the refractive index of the colloidal solution of quantum dots, and it may be possible to use a colloidal solution of quantum dots with a refractive index the same as or possibly a little lower than the refractive index of the cladding,  
30 with the refractive index of the core being higher than that of the cladding.

Also, the cladding may include more than one opening that receives the

- 8 -

colloidal solution of quantum dots, e.g. in the manner of a multi-core optical fibre.

Whilst the colloid described in the examples comprises quantum dots  
5 dispersed in a liquid support medium, other states of support medium could be used, e.g. solids and gases.

In any or all of these constructions, the fibre may be formed from a non-silica  
glass such as a fluoride glass, or even a non-vitreous material such as a plastics  
10 material e.g. PMMA.

The optical amplifier described herein can be used in a resonant cavity to  
provide a laser. For example, the fibre as shown in Figure 4 can be provided  
with semi-refractive surfaces at the splice 6 and at the free end, to provide a  
15 Fabry-Perot resonant cavity. If desired, a pigtail fibre with refractive index  
grating may be attached to the free end of the fibre 1 to tune the cavity.

In another modification, the colloid of quantum dots may be used in a  
waveguide structure, which may itself be included in a resonant cavity e.g. to  
20 provide a laser, in which the waveguide is not a fibre defined by a cladding,  
but instead a channel formed in a substrate or some other non-fibre  
confirming structure.

As used herein, the term "optical" includes both visible and non-visible optical  
25 radiation, such as ultra violet and infrared.

## Claims

1. An optical fibre with a light guiding region characterised by a colloid of quantum dots (3,4) therein.
- 5 2. An optical fibre according to claim 1 wherein the material of the quantum dots (4) is a III-V, II-VI or I-VII material or an alloy thereof.
3. An optical fibre according to claim 1 or 2 wherein the material of the  
10 quantum dots (4) is selected from CdS, CdSe, PbS, ZnS, ZnO, TiO<sub>2</sub>, AgI, AgBr, HgI<sub>2</sub>, PbSe, ZnTe, CdTe, In<sub>2</sub>S<sub>3</sub>, In<sub>2</sub>Se<sub>3</sub>, Cd<sub>3</sub>P<sub>2</sub>, Cd<sub>3</sub>As<sub>2</sub> and GaAs.
4. An optical fibre according to any preceding claim wherein the dots have a diameter range of 1-50 nm.
- 15 5. An optical fibre according to any preceding claim wherein the dots have a diameter range of 1-20 nm.
6. An optical fibre according to any preceding claim wherein the  
20 quantum dots have a diameter range of 1.3-2.0 nm.
7. An optical fibre according to claim 1 wherein the quantum dots have a diameter range of 5-10 nm and are formed of PbS material.
- 25 8. An optical fibre according to any preceding claim wherein the colloid includes a non-vitreous support medium in which the dots are dispersed.
9. An optical fibre according to claim 9 wherein the support medium comprises an organic liquid.
- 30 10. An optical fibre according to any preceding claim wherein the support medium is selected from dichlorobenzene, toluene, benzene, nitrobenzene,

- 10 -

pyridene and carbon tetrachloride.

11. An optical fibre according to any preceding claim wherein the quantum dots are formed from a first semiconductor material coated with a second different semiconductor material.
12. An optical fibre according to any preceding claim incorporated in an optical amplifier.
13. An optical fibre according to any one of claims 1 to 12 including pumping means (11) for optically pumping the fibre, and input means (10) for applying input signals to be amplified to the fibre.
14. An optical fibre according to any preceding claim and operative as a wavelength converter.
15. An optical fibre according to any preceding claim wherein the fibre includes a core and a cladding (1), and the colloid of quantum dots (3,4) forms at least a part of the core.
16. An optical fibre according to claim 15 wherein the cladding is made of glass.
17. An optical fibre according to claim 15 wherein the cladding is tubular and includes an opening (2) filled with the colloid.
18. A method of making an optical fibre according to claim 16 or 17 including causing the colloid of quantum dots to enter the opening at least in part by capillary action.
19. A method according to claim 18 including applying negative pressure to one end of the fibre to assist in drawing the colloid therein.

- 11 -

20. A method of making an optical fibre according any one of claims 1 to 17 wherein the quantum dots are formed initially by precipitation from a salt solution.
- 5 21. A method according to claim 20 wherein the precipitated dots are dried and then dispersed in the support medium.
22. A waveguide that includes an optical active component that comprises a colloid of quantum dots (4).
- 10 23. A waveguide according to claim 21 included in a laser resonant cavity.
24. A waveguide according to claim 21 or 22 including a channel in a substrate that contains said colloid of quantum dots.
- 15 25. An optical fibre characterised by a colloid of quantum dots therein.

1/1

FIG. 1

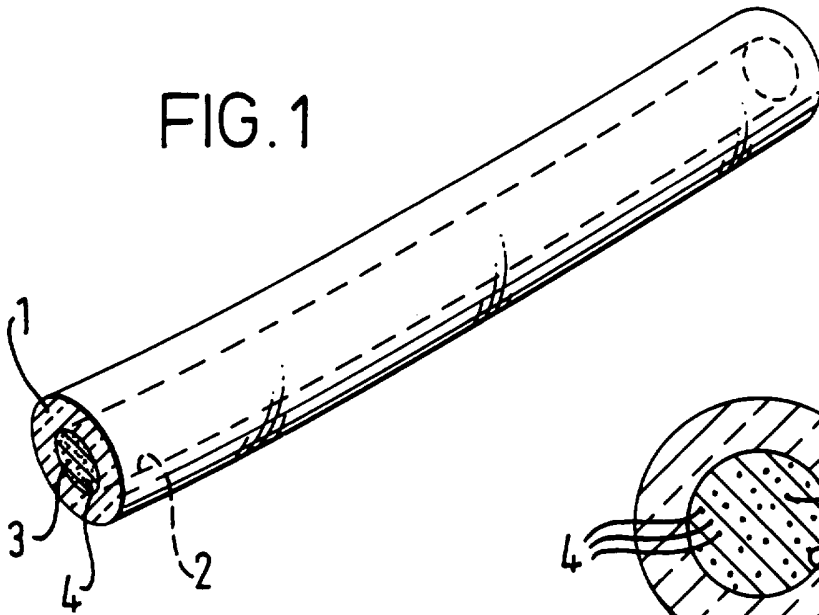

FIG. 2

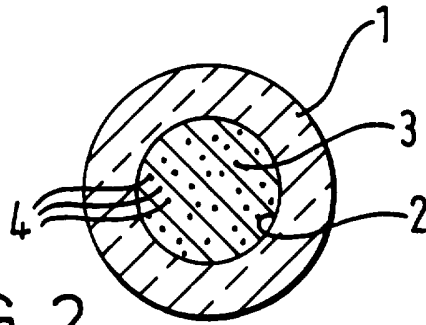

FIG. 3

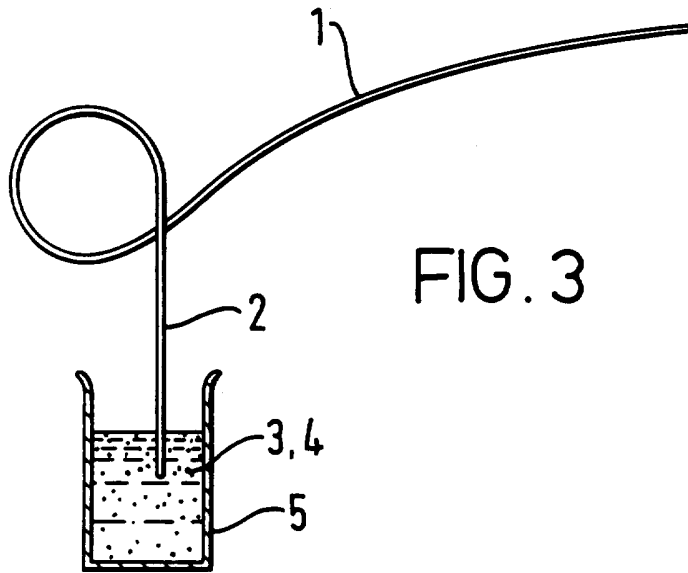
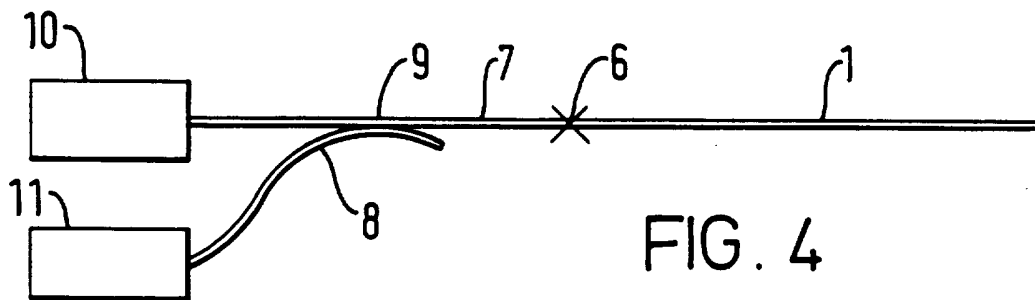

FIG. 4



**INTERNATIONAL SEARCH REPORT**

International Application No  
PCT/GB 95/02322

**A. CLASSIFICATION OF SUBJECT MATTER**  
IPC 6 H01S3/19 H01S3/06 G02B6/20 G02F1/35

According to International Patent Classification (IPC) or to both national classification and IPC

**B. FIELDS SEARCHED**  
Minimum documentation searched (classification system followed by classification symbols)  
IPC 6 H01S G02B H01L G02F C03C

Documentation searched other than minimum documentation to the extent that such documents are included in the fields searched

Electronic data base consulted during the international search (name of data base and, where practical, search terms used)

**C. DOCUMENTS CONSIDERED TO BE RELEVANT**

Category *	Citation of document, with indication, where appropriate, of the relevant passages	Relevant to claim No.
Y	EP,A,0 328 202 (PHILIPS ELECTRONIC AND ASSOCIATED IND. ET AL.) 16 August 1989 see column 4, line 5 - line 56	1-9, 15-18,25
A	see column 9, line 5 - column 10, line 26 ---	21-24
Y	DATABASE WPI Section Ch, Week 9235 Derwent Publications Ltd., London, GB; Class L01, AN 92-287166 & JP,A,04 195 028 (FURUKAWA ELECTRIC CO LTD) , 15 July 1992 cited in the application see abstract ---	1-9, 15-18,25
	-/--	

Further documents are listed in the continuation of box C.       Patent family members are listed in annex.

\* Special categories of cited documents :

- \*A\* document defining the general state of the art which is not considered to be of particular relevance
- \*E\* earlier document but published on or after the international filing date
- \*L\* document which may throw doubts on priority claim(s) or which is cited to establish the publication date of another citation or other special reason (as specified)
- \*O\* document referring to an oral disclosure, use, exhibition or other means
- \*P\* document published prior to the international filing date but later than the priority date claimed
- \*T\* later document published after the international filing date or priority date and not in conflict with the application but cited to understand the principle or theory underlying the invention
- \*X\* document of particular relevance; the claimed invention cannot be considered novel or cannot be considered to involve an inventive step when the document is taken alone
- \*Y\* document of particular relevance; the claimed invention cannot be considered to involve an inventive step when the document is combined with one or more other such documents, such combination being obvious to a person skilled in the art.
- \*&\* document member of the same patent family

Date of the actual completion of the international search  18 December 1995	Date of mailing of the international search report  10. 01. 96
---	--

Name and mailing address of the ISA European Patent Office, P.B. 5818 Patentlaan 2 NL - 2280 HV Rijswijk Tel. (+ 31-70) 340-2040, Tx. 31 651 epo nl, Fax (+ 31-70) 340-3016	Authorized officer  von Moers, F
---	--

INTERNATIONAL SEARCH REPORT

International Application No  
PCT/GB 95/02322

C.(Continuation) DOCUMENTS CONSIDERED TO BE RELEVANT

Category	Citation of document, with indication, where appropriate, of the relevant passages	Relevant to claim No.
A	<p>FIBER OPTIC AND LASER SENSORS IX, BOSTON, MA, USA, 3-5 SEPT. 1991, vol. 1584, ISSN 0277-786X, PROCEEDINGS OF THE SPIE - THE INTERNATIONAL SOCIETY FOR OPTICAL ENGINEERING, 1991, USA, pages 435-447, GHATAK K P 'The thermoelectric power in fiber optic and laser materials under cross field configuration' see page 441, paragraph 2</p>	1,25
A	<p>JOURNAL OF PHYSICAL CHEMISTRY, vol. 98, no. 3, 20 January 1994 USA, pages 934-941, A.MEWS ET AL. 'Preparation, characterization, and photophysics of the quantum dot quantum well system CdS/HgS/CdS' cited in the application see page 935</p>	11
X	<p>US,A,5 260 957 (HAKIMI ET AL) 9 November 1993 cited in the application see column 2, line 41 - column 3, line 30; figures 1-5</p>	22-24
A	<p>OPTICAL FIBER COMMUNICATION CONFERENCE '92, TECHNICAL DIGEST, vol. 5, 2 February 1992 SAN JOSE, US, page 71 TAUBER ET AL. see page 71; figure 1</p>	12,13
A	<p>WO,A,93 08500 (INTELLECTUAL PROPERTY DEVELOPEMENT ASSOCIATES OF CONNETICUT) 29 April 1993 see abstract</p>	14
A	<p>JOURNAL OF PHYSICAL CHEMISTRY, vol. 97, no. 46, 1993 USA, pages 11999-12003, T RAJH ET AL. 'Synthesis and characterization of surface-modified colloidal CdTe quantum dots' see page 11999</p>	1,22,25
A	<p>PROC. OF THE SPIE, vol. 1337, 1990 pages 132-141, SCHWERZEL ET AL. 'Nonlinear optical properties of colloidal "quantum-dot" composite materials with tailored organic coatings' see abstract</p>	1,22,25
	-/--	

1



**INTERNATIONAL SEARCH REPORT**

International Application No  
**PCT/GB 95/02322**

**C.(Continuation) DOCUMENTS CONSIDERED TO BE RELEVANT**

Category	Citation of document, with indication, where appropriate, of the relevant passages	Relevant to claim No.
P,A	PATENT ABSTRACTS OF JAPAN vol. 95 no. 1,28 February 1995 & JP,A,06 301071 (MITSUI TOATSU CHEM.) 28 October 1994, see abstract <p align="center">-----</p>	1-7,25

# INTERNATIONAL SEARCH REPORT

Information on patent family members

International Application No

PCT/GB 95/02322

Patent document cited in search report	Publication date	Patent family member(s)	Publication date
EP-A-328202	16-08-89	GB-A- 2215122	13-09-89
		JP-A- 1244611	29-09-89
-----			
US-A-5260957	09-11-93	NONE	
-----			
WO-A-9308500	29-04-93	US-A- 5253258	12-10-93
		AU-B- 662766	14-09-95
		AU-A- 2870692	21-05-93
		GB-A- 2276731	05-10-94
		GB-A- 2289159	08-11-95
		GB-A- 2289137	08-11-95
		US-A- 5383038	17-01-95
-----			