



US00RE47172E

(19) **United States**  
(12) **Reissued Patent**  
**Tannoury et al.**

(10) **Patent Number:** **US RE47,172 E**  
(45) **Date of Reissued Patent:** **Dec. 25, 2018**

(54) **SPINAL DISC PREPARATION TOOL**  
(71) Applicant: **DePuy Synthes Products, Inc.**,  
Raynham, MA (US)  
(72) Inventors: **Tony Tannoury**, Andover, MA (US);  
**Michael O'Neil**, Mansfield, MA (US);  
**Hassan A. Serhan**, South Easton, MA  
(US); **Anwar M. Upal**, Fall River, MA  
(US); **Michael A. Slivka**, Taunton, MA  
(US); **John Riley Hawkins**,  
Cumberland, RI (US)

4,043,343 A \* 8/1977 Williams ..... 606/207  
4,314,565 A \* 2/1982 Lee ..... A61B 10/0283  
600/566  
4,369,788 A 1/1983 Goald  
4,446,989 A \* 5/1984 Brannen ..... B67B 7/26  
222/108  
4,522,206 A \* 6/1985 Whipple et al. .... 606/174  
4,573,448 A 3/1986 Kambin  
5,275,609 A \* 1/1994 Pingleton et al. .... 606/170  
(Continued)

(73) Assignee: **DePuy Synthes Products, Inc.**,  
Raynham, MA (US)

EP 0 463 798 A1 1/1992  
EP 0 538 984 A2 4/1993  
(Continued)

(21) Appl. No.: **14/737,233**

(22) Filed: **Jun. 11, 2015**

**FOREIGN PATENT DOCUMENTS**

**Related U.S. Patent Documents**

Reissue of:

(64) Patent No.: **8,936,598**  
Issued: **Jan. 20, 2015**  
Appl. No.: **12/353,677**  
Filed: **Jan. 14, 2009**

**OTHER PUBLICATIONS**

\*\*International Search Report, PCT/US2010/020722, dated Mar.  
22, 2010 (4 pages).

(Continued)

(51) **Int. Cl.**  
**A61B 17/32** (2006.01)  
**A61B 17/00** (2006.01)

*Primary Examiner* — Cary E Wehner

(74) *Attorney, Agent, or Firm* — Nutter McClennen &  
Fish LLP

(52) **U.S. Cl.**  
CPC .... **A61B 17/32** (2013.01); **A61B 2017/00261**  
(2013.01); **A61B 2017/320064** (2013.01)

(57) **ABSTRACT**

(58) **Field of Classification Search**  
CPC ..... **A61B 2017/320064**; **A61B 2017/32008**  
USPC ..... **606/79, 83-85, 160, 170, 175, 181;**  
**600/564-566, 570, 571**  
See application file for complete search history.

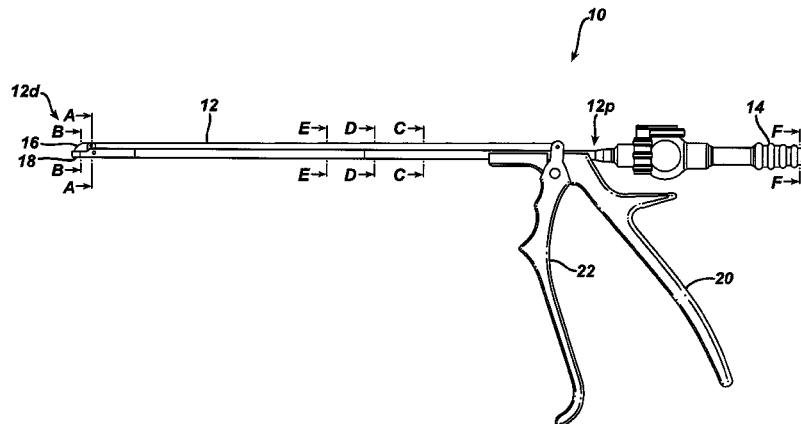
A spinal disc preparation tool is provided that includes an elongate shaft having an inner lumen extending therethrough along a longitudinal axis between proximal and distal ends thereof. A lower jaw is located on a distal end of the elongate shaft for receiving tissue and delivering tissue to the inner lumen, and an upper jaw is pivotally movable relative to the lower jaw. The tool can include various features to facilitate removal and/or collection of tissue.

(56) **References Cited**

**U.S. PATENT DOCUMENTS**

2,600,803 A \* 6/1952 Prather ..... 433/146  
2,994,321 A \* 8/1961 Tischler ..... A61B 10/02  
600/564

**46 Claims, 21 Drawing Sheets**



(56)

References Cited

U.S. PATENT DOCUMENTS

5,286,255 A 2/1994 Weber  
 5,354,311 A 10/1994 Kambin et al.  
 5,395,317 A 3/1995 Kambin  
 5,433,725 A 7/1995 Christian et al.  
 5,439,464 A 8/1995 Shapiro  
 5,562,695 A \* 10/1996 Obenchain ..... A61B 17/32001  
 606/167  
 5,601,586 A \* 2/1997 Fucci ..... A61B 17/32002  
 138/122  
 5,618,294 A \* 4/1997 Aust et al. .... 606/170  
 5,620,415 A 4/1997 Lucey et al.  
 5,653,713 A \* 8/1997 Michelson ..... 606/83  
 5,683,359 A 11/1997 Farkas et al.  
 5,702,420 A 12/1997 Sterling et al.  
 5,785,647 A 7/1998 Tompkins et al.  
 5,797,927 A \* 8/1998 Yoon ..... A61B 17/0469  
 606/139  
 5,797,939 A 8/1998 Yoon  
 5,797,958 A 8/1998 Yoon  
 5,810,826 A \* 9/1998 Åkerfeldt et al. .... 606/80  
 5,810,883 A \* 9/1998 Lang ..... A61B 17/1608  
 600/564  
 5,851,214 A \* 12/1998 Larsen et al. .... 606/170  
 5,893,863 A 4/1999 Yoon  
 5,904,647 A \* 5/1999 Ouchi ..... 600/104  
 5,919,202 A 7/1999 Yoon  
 5,919,206 A \* 7/1999 Gengler ..... A61B 17/295  
 606/170  
 5,922,001 A 7/1999 Yoon  
 5,922,002 A 7/1999 Yoon  
 5,984,938 A 11/1999 Yoon  
 5,984,939 A \* 11/1999 Yoon ..... 606/170  
 5,997,896 A \* 12/1999 Carr et al. .... 424/426  
 6,007,496 A 12/1999 Brannon  
 6,083,150 A \* 7/2000 Aznoian et al. .... 600/564  
 6,709,445 B2 \* 3/2004 Boebel ..... A61B 17/29  
 600/564  
 6,939,351 B2 9/2005 Eckman  
 7,204,811 B2 4/2007 Kortenbach et al.  
 7,375,325 B2 5/2008 Burkhardt et al.  
 7,641,667 B2 \* 1/2010 Sample ..... A61B 17/32002  
 407/112  
 8,679,133 B2 \* 3/2014 Peterson ..... A61B 17/32070  
 606/131  
 8,936,598 B2 1/2015 Tannoury et al.  
 2002/0107457 A1 \* 8/2002 Francese et al. .... 600/564  
 2002/0133148 A1 \* 9/2002 Daniel et al. .... 606/34  
 2003/0135218 A1 7/2003 Eckman

2004/0243157 A1 \* 12/2004 Connor et al. .... 606/159  
 2004/0260198 A1 \* 12/2004 Rothberg et al. .... 600/564  
 2005/0038439 A1 2/2005 Eckman  
 2005/0216019 A1 9/2005 Eckman  
 2005/0222600 A1 \* 10/2005 Yamaguchi ..... A61B 17/1608  
 606/184  
 2005/0267503 A1 \* 12/2005 Hunstad ..... 606/170  
 2005/0273084 A1 12/2005 Hinman et al.  
 2006/0167450 A1 \* 7/2006 Johnson et al. .... 606/48  
 2006/0167461 A1 \* 7/2006 Hawkins et al. .... 606/90  
 2006/0224160 A1 10/2006 Trieu et al.  
 2006/0247668 A1 \* 11/2006 Park ..... 606/160  
 2006/0258954 A1 \* 11/2006 Timberlake ..... A61B 10/06  
 600/564  
 2007/0055215 A1 \* 3/2007 Tran ..... A61B 10/0275  
 604/540  
 2007/0055264 A1 \* 3/2007 Parmigiani ..... A61B 17/1635  
 606/84  
 2007/0088362 A1 4/2007 Bonutti et al.  
 2007/0191857 A1 8/2007 Allard et al.  
 2007/0265633 A1 \* 11/2007 Moon et al. .... 606/83  
 2008/0058850 A1 \* 3/2008 Feiler ..... A61B 17/3203  
 606/184  
 2010/0179578 A1 7/2010 Tannoury et al.

FOREIGN PATENT DOCUMENTS

EP 0 541 377 A1 5/1993  
 EP 0 614 647 A2 9/1994  
 WO 92/07516 A1 5/1992  
 WO 95/19145 A1 7/1995  
 WO 96/22056 A1 7/1996  
 WO 99/58066 A1 11/1999  
 WO 02/089722 A1 11/2002

OTHER PUBLICATIONS

\*\*International Preliminary Report on Patentability for Application No. PCT/US2010/020722, dated Jul. 28, 2011 (9 pages).  
 \*\*Pfeiffer, M., et al., Arch Orthop Trauma Surg. (1990) 109:211-216, "Automated percutaneous lumbar discectomy with and without chymopapain pretreatment versus non-automated, discoscopy-monitored percutaneous lumbar discectomy."  
 International Search Report, PCT/US2010/020722, dated Mar. 22, 2010.  
 Kambin and Savitz, The Mount Sinai Journal of Medicine, vol. 67, No. 4, Sep. 2000, "Arthroscopic MicroDiscectomy: An Alternative to Open Disc Surgery", p. 283-287.  
 Kambin and Schaffer, "Kambin Arthroscopic Microdiscectomy System", Smith & Nephew Spine, Feb. 1994.

\* cited by examiner

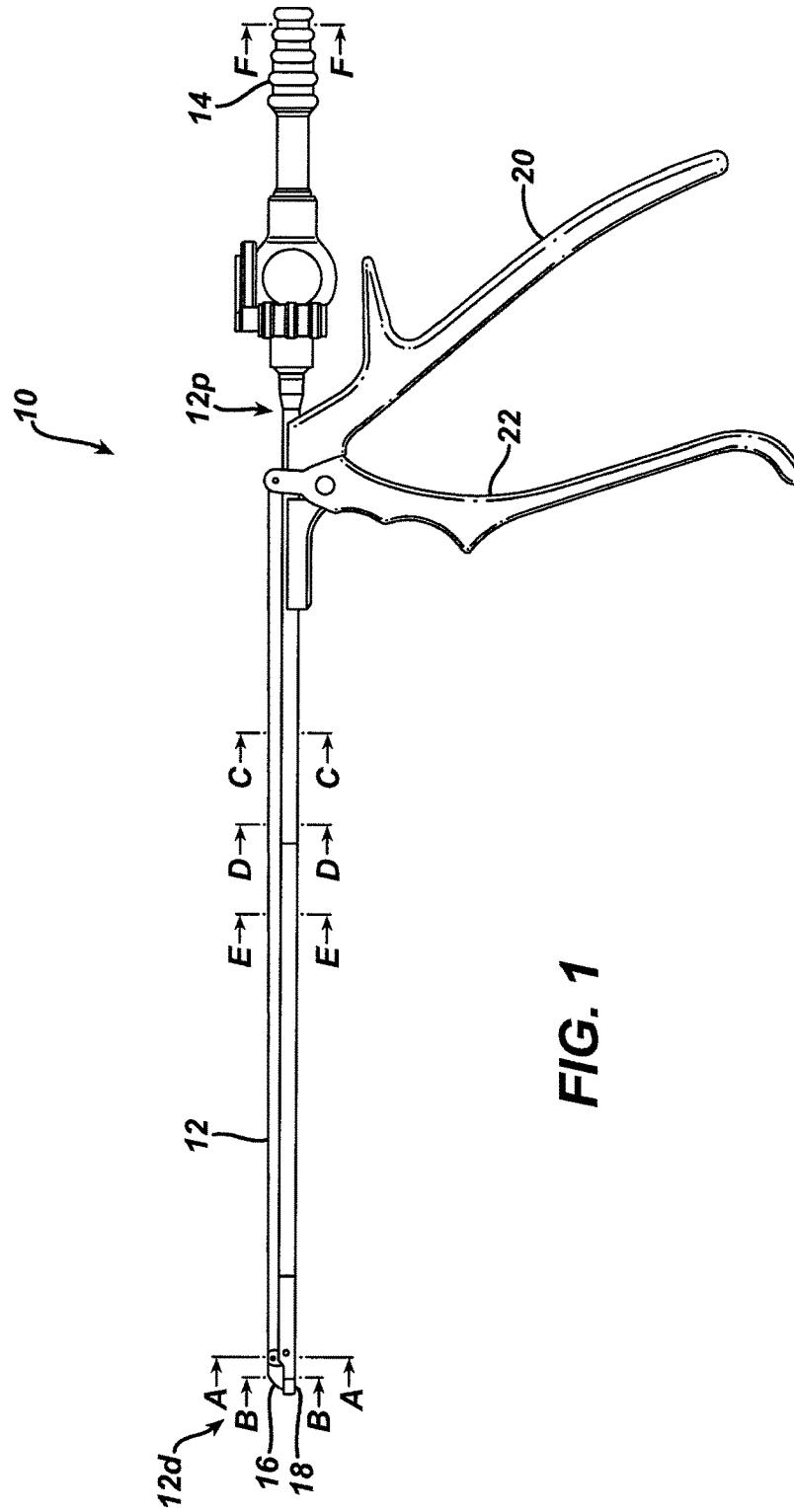


FIG. 1

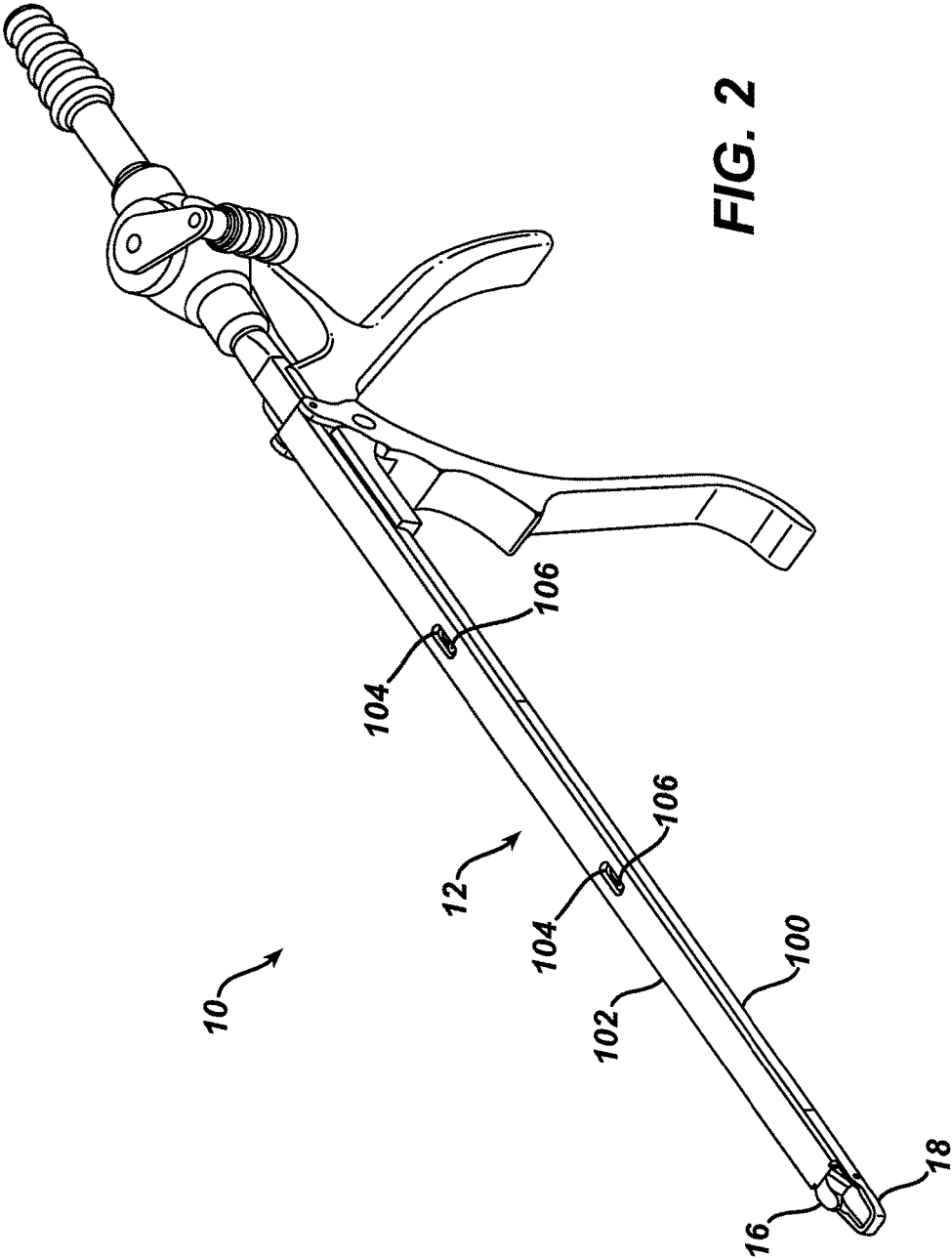


FIG. 2

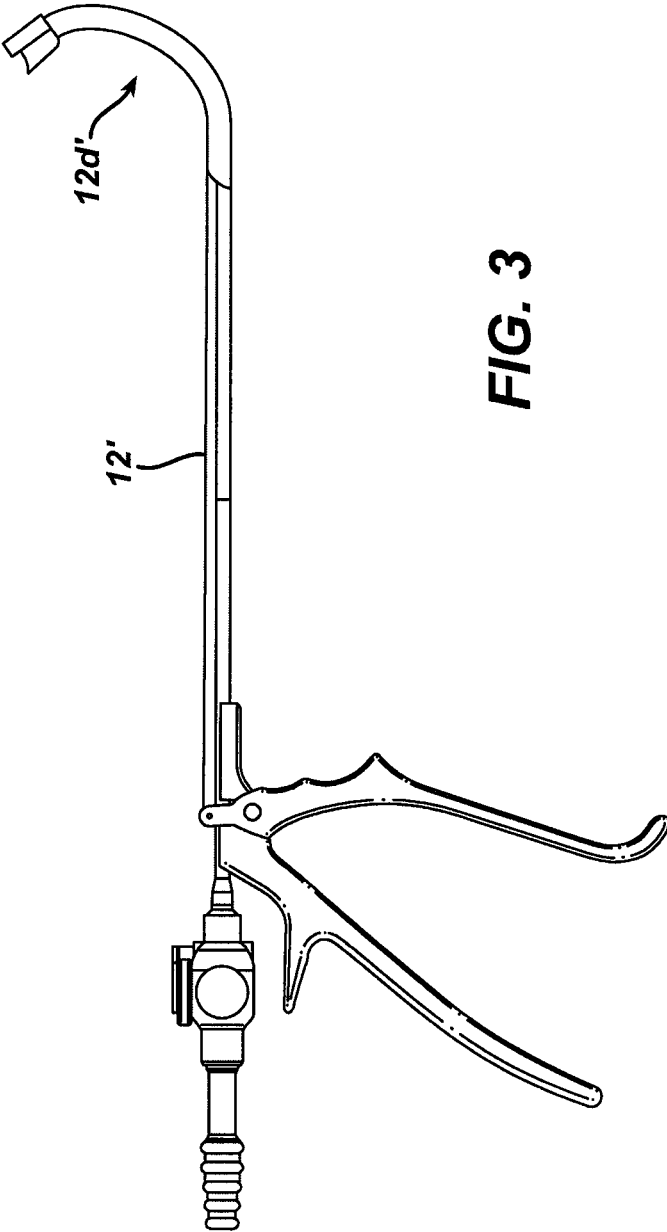
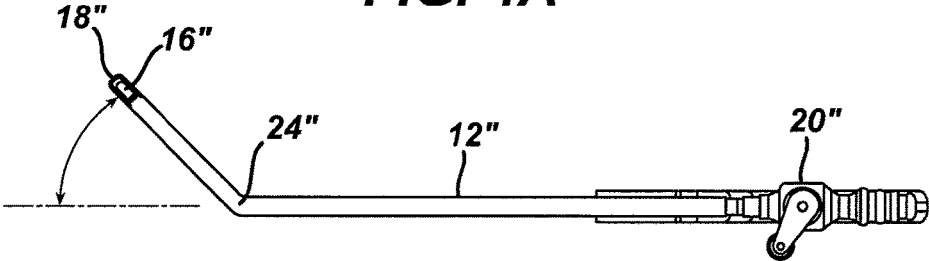
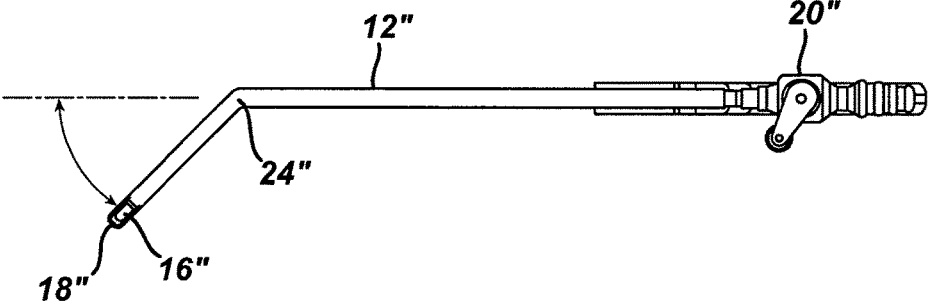


FIG. 3

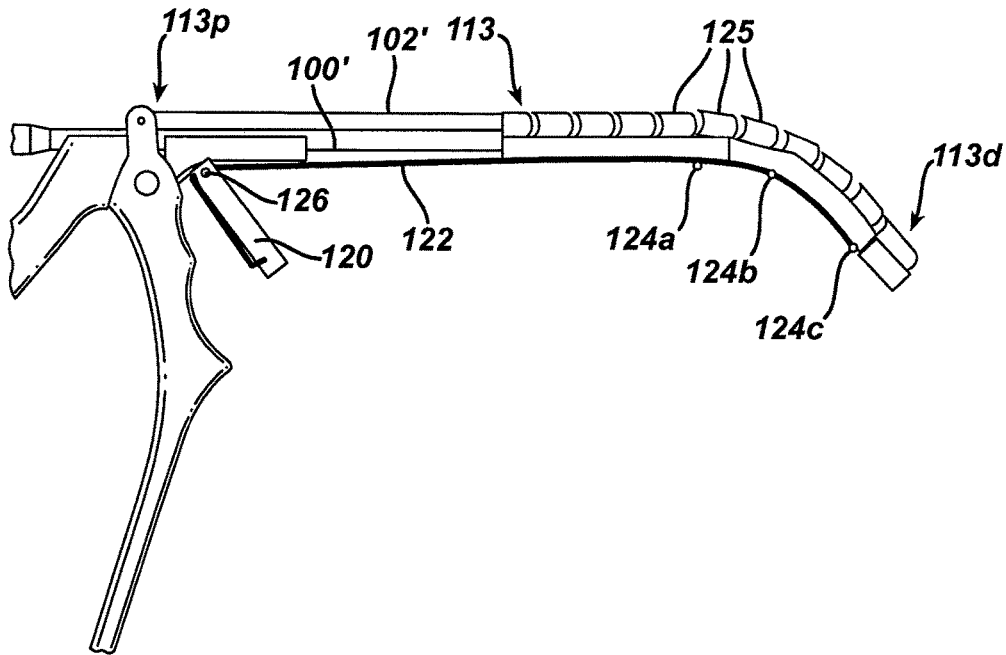
**FIG. 4A**



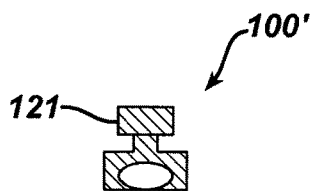
**FIG. 4B**



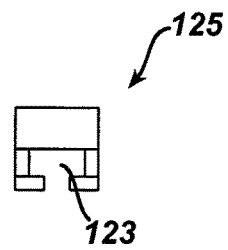
**FIG. 5A**



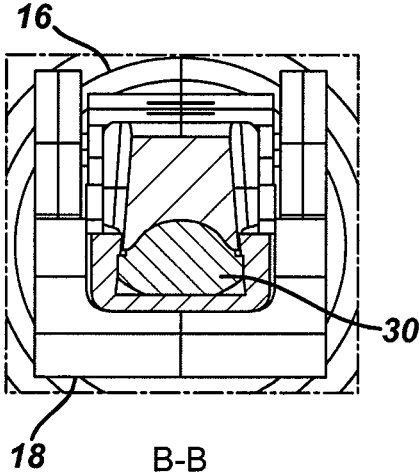
**FIG. 5B**



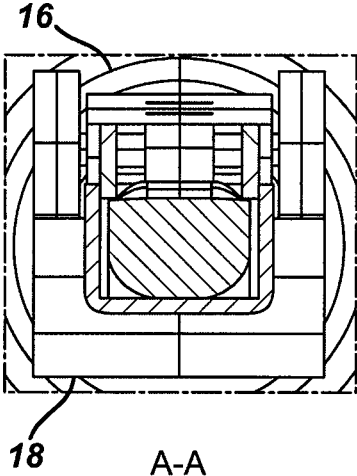
**FIG. 5C**



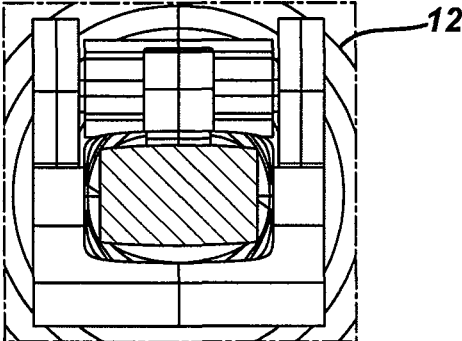
**FIG. 6A**



**FIG. 6B**

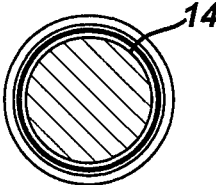


**FIG. 6C**



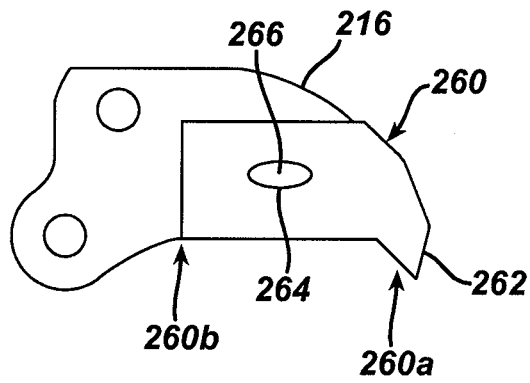
C-C thru E-E

**FIG. 6D**

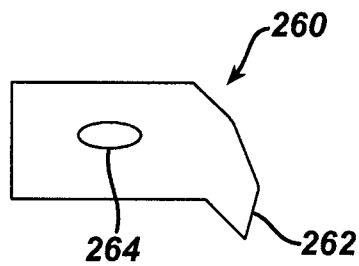


F-F

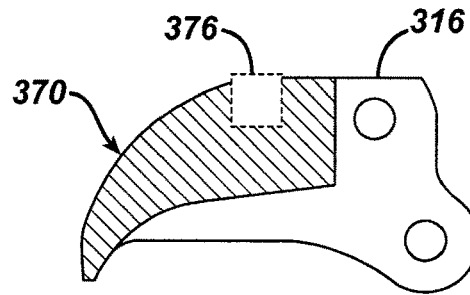
**FIG. 7A**



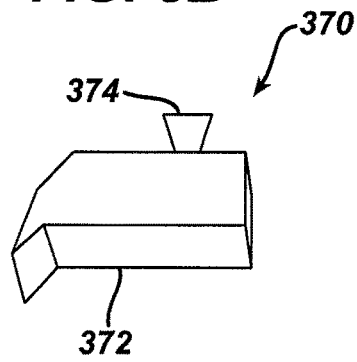
**FIG. 7B**



**FIG. 8A**



**FIG. 8B**



**FIG. 8C**

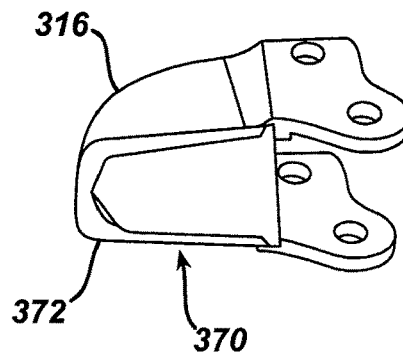
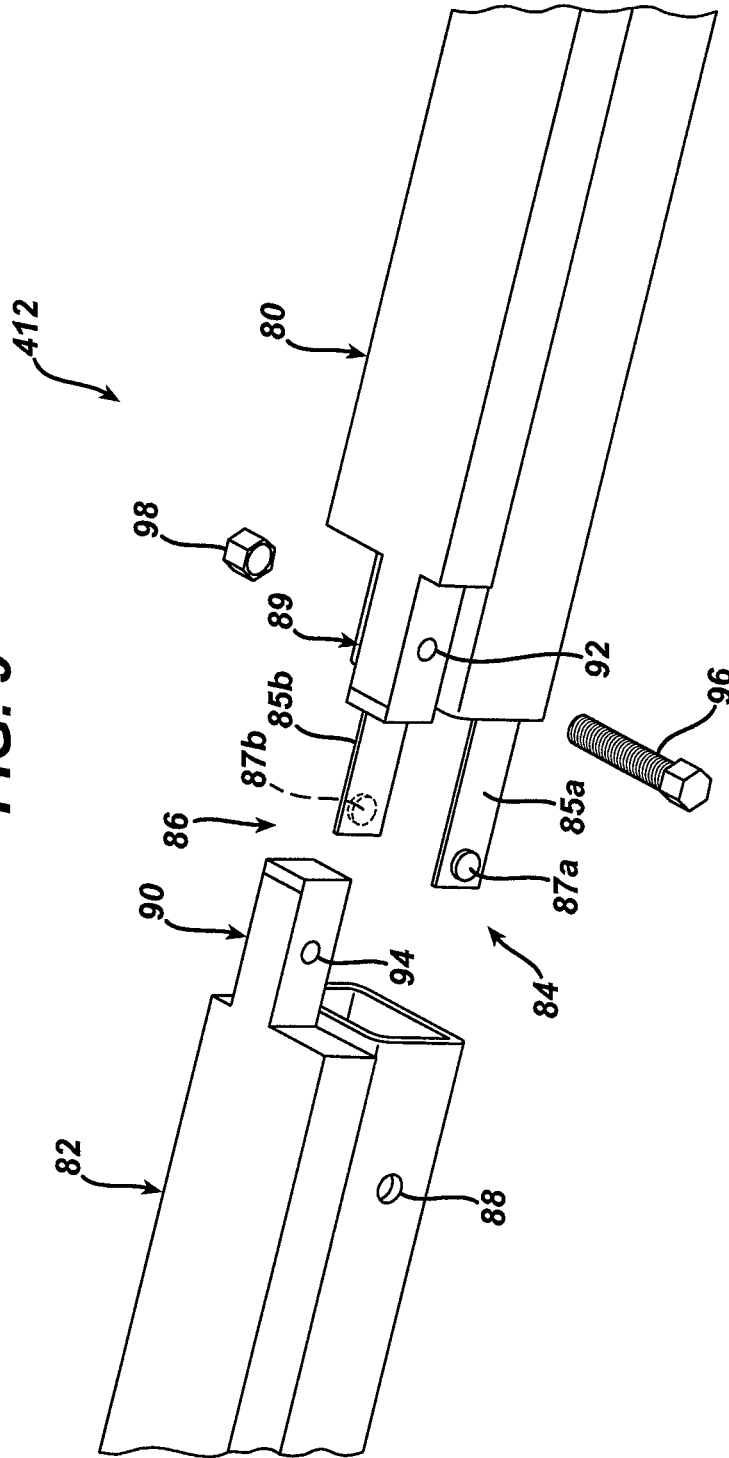
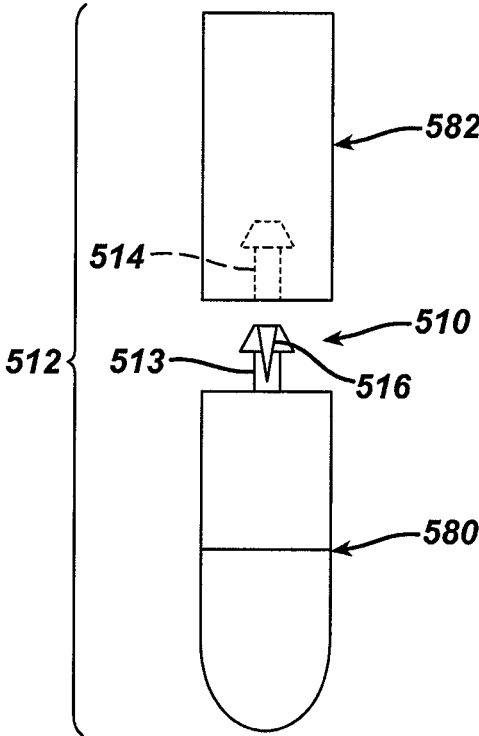


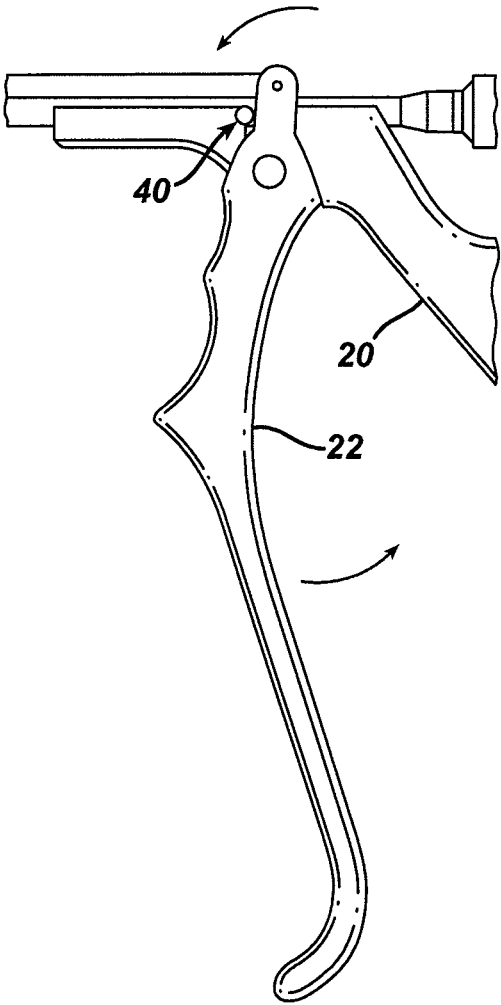
FIG. 9



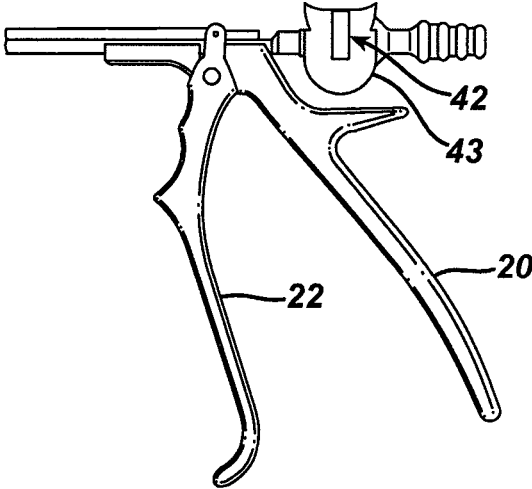
**FIG. 10**



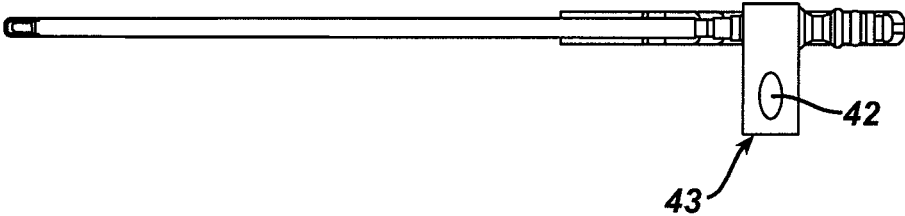
**FIG. 11**



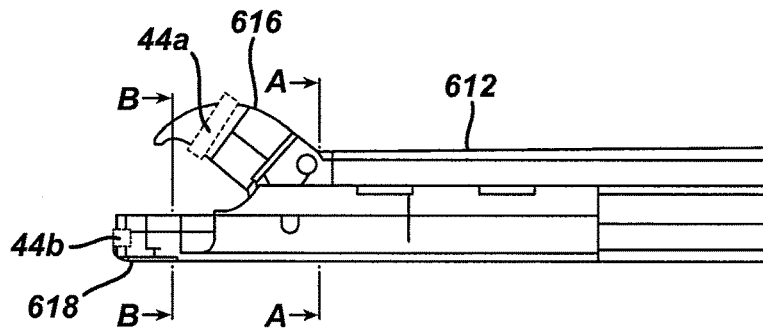
**FIG. 12A**



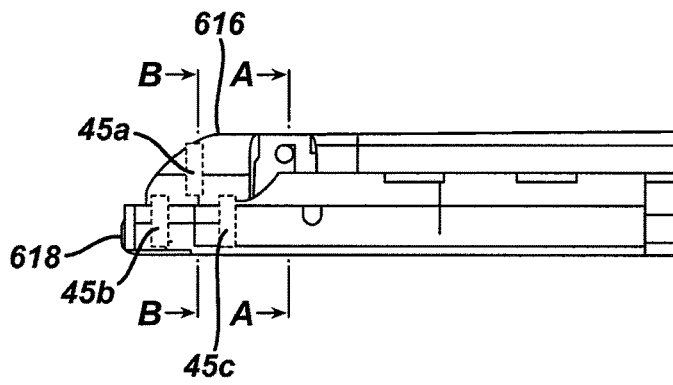
**FIG. 12B**



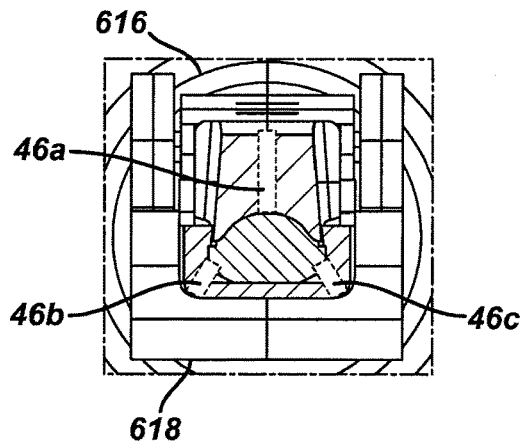
**FIG. 13**



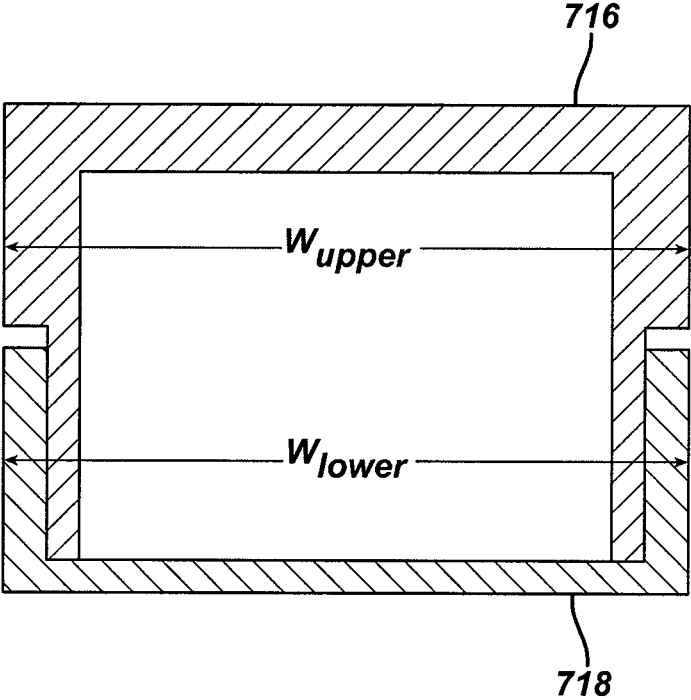
**FIG. 14A**



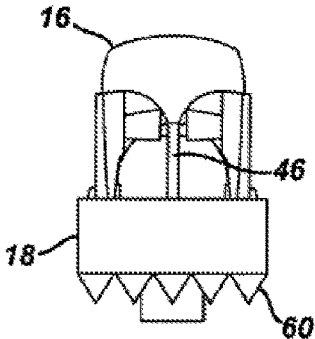
**FIG. 14B**



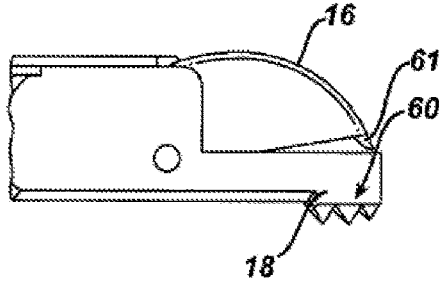
**FIG. 15**



**FIG. 16A**

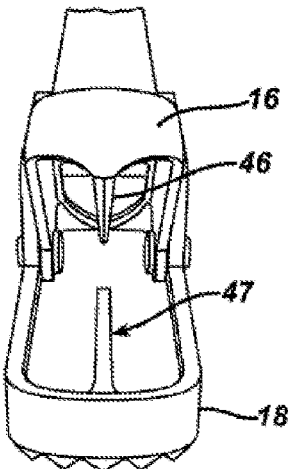


**FIG. 16B**

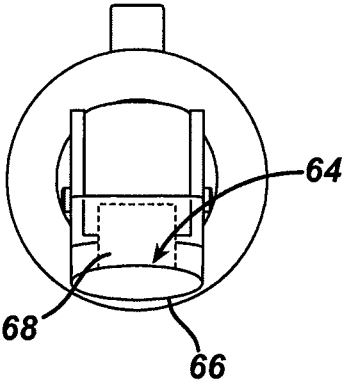


Amended

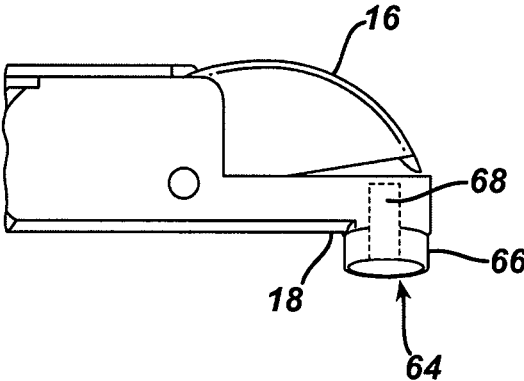
**FIG. 16C**



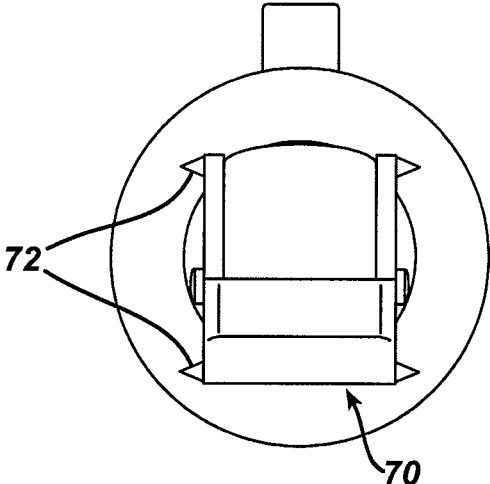
**FIG. 17A**



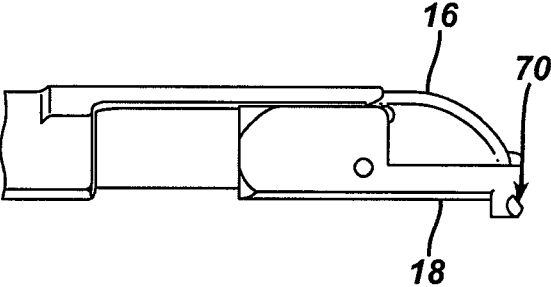
**FIG. 17B**



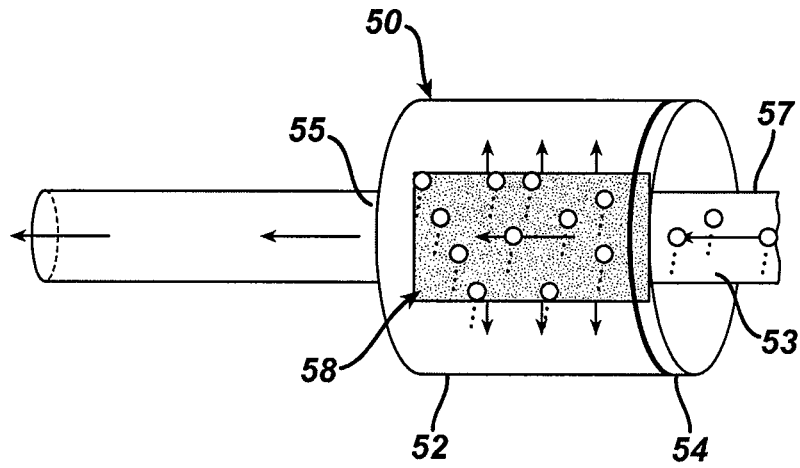
**FIG. 18A**



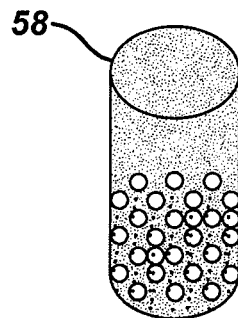
**FIG. 18B**



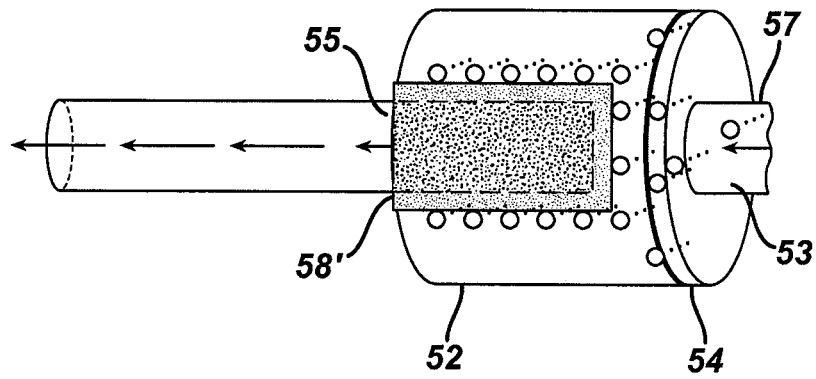
**FIG. 19A**



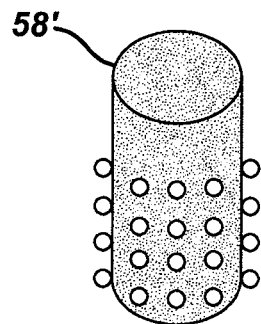
**FIG. 19B**



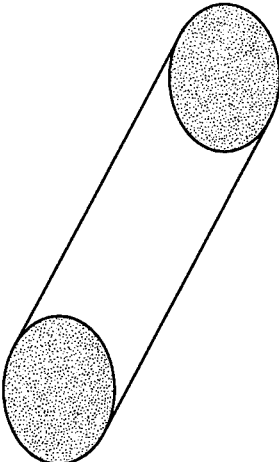
**FIG. 20A**



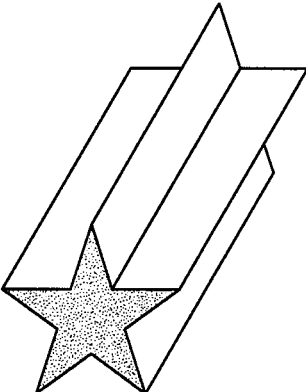
**FIG. 20B**



**FIG. 21**



**FIG. 22**



## SPINAL DISC PREPARATION TOOL

**Matter enclosed in heavy brackets [ ] appears in the original patent but forms no part of this reissue specification; matter printed in italics indicates the additions made by reissue; a claim printed with strikethrough indicates that the claim was canceled, disclaimed, or held invalid by a prior post-patent action or proceeding.**

*This application is a broadening reissue of U.S. Pat. No. 8,936,598.*

## FIELD OF THE INVENTION

The present invention relates to devices and methods for preparing adjacent vertebrae for a disc replacement.

## BACKGROUND OF THE INVENTION

Various physical conditions can manifest themselves in the form of damage or degeneration of an intervertebral disc, the result of which is mild to severe chronic back pain. Intervertebral discs serve as "shock" absorbers for the spinal column, absorbing pressure delivered to the spinal column. Additionally, they maintain the proper anatomical separation between two adjacent vertebra. This separation is necessary for allowing both the afferent and efferent nerves to exit and enter, respectively, the spinal column.

Treatment for a diseased or damaged disc can involve partial or complete removal of the affected disc and implantation of a spinal disc replacement for fusion or non-fusion purposes. A discectomy to remove a spinal disc can involve multiple passes into an out of the disc space between vertebrae, and each one of these passes to remove the disc tissue can increase the risk of nerve injury and contamination of the disc space. In addition, each pass becomes time consuming for the surgeon as there must be a focus with each pass on proper entry into the disc space, removing a portion of tissue, and manually clearing the device of the removed tissue to prepare the device for the subsequent pass into the disc space. During these procedures, it can also be advantageous to prepare the vertebral endplates for the implantation of a disc implant, which is routinely achieved using a separate tool.

Accordingly, there is a need for improved methods and devices for preparing an intervertebral disc space.

## SUMMARY OF THE INVENTION

The present invention provides various devices and methods for preparing an intervertebral disc space. In one embodiment, a spinal disc preparation tool is provided and includes an elongate shaft having an inner lumen extending therethrough along a longitudinal axis between proximal and distal ends thereof. A lower jaw is located on a distal end of the elongate shaft for receiving tissue and delivering tissue to the inner lumen, and an upper jaw is pivotally movable relative to the lower jaw. The upper and lower jaws define a tissue-receiving cavity having a maximum cross-sectional area taken transverse to the longitudinal axis that is less than a cross-sectional area of the inner lumen of the elongate shaft taken transverse to the longitudinal axis at a distal opening of the inner lumen. For example, the cross-sectional area of the tissue-receiving cavity can be about 50% less than the cross-sectional area of the inner lumen at the distal

opening of the inner lumen. In one exemplary embodiment, the inner lumen has a cross-sectional area taken transverse to the longitudinal axis that increases from the distal opening to a proximal end of the inner lumen, and for example, the cross-sectional area at the proximal end of the inner lumen can be about twice the cross-sectional area at the distal opening of the inner lumen. In another exemplary embodiment, the upper and lower jaws can be removably and replaceably coupled to the elongate shaft.

The upper and lower jaws can also include features to facilitate aspiration of the tissue. In one embodiment, at least one of the jaws includes one or more holes formed therein for allowing gas and/or fluid to pass therethrough to aid in aspiration of cut tissue through the inner lumen. At least one of the jaws can also include an inner surface having a coating for aiding in aspiration of cut tissue through the inner lumen. For example, the coating can be hydrophilic and provide a lubricated surface within at least one of the jaws, or the coating can be hydrophobic such that the coating repels fluid and prevents adhesion of cut tissue to the upper jaw and/or lower jaw. In another embodiment, a septum can be formed in the lower jaw and it can be configured to separate cut tissue into two portions. In other aspects, the lower jaw can be removably and replaceably coupled to the elongate shaft. The upper and lower jaws can also include features to prepare the area surrounding the spinal disc, such as at least one bone cutting element that can be formed on at least one of the upper and lower jaws. In another embodiment, the upper jaw can have a width that is equal or greater to a width of the lower jaw.

In other embodiments, the tool can include a handle coupled to a proximal end of the elongate shaft and having an actuator operatively associated with the upper jaw for pivoting the upper jaw relative to the lower jaw. An aspiration hole can be formed in the handle and it can be in fluid communication with the inner lumen. In one embodiment, the aspiration hole is positioned such that the aspiration hole is blocked by the actuator when the actuator is actuated. The tool can also include a tissue collection chamber in fluid communication with the inner lumen and configured to separate cut tissue from fluid. The tool can include other features as well, such as an articulation joint formed in the shaft for allowing angular orientation of the distal end of the shaft.

In another embodiment, a spinal disc preparation tool is provided and includes an elongate shaft having an inner lumen extending therethrough along a longitudinal axis between proximal and distal ends thereof, and upper and lower jaws disposed on a distal end of the elongate shaft. The upper jaw is movable relative to the lower jaw to cut tissue therebetween and deliver tissue to the inner lumen of the elongate shaft. At least one of the upper and lower jaws is removably and replaceably coupled to the elongate shaft. In one embodiment, the upper jaw can include a removable hood or a removable insert having a blade thereon for cutting tissue. In another exemplary embodiment, the upper and lower jaws can be coupled to a distal portion of the elongate shaft, and the distal portion of the elongate shaft can be removably coupled to a proximal portion of the elongate shaft such that the distal portion of the elongate shaft and the upper and lower jaws are removable and replaceable.

In another embodiment, a spinal disc preparation tool is provided and includes an elongate shaft having an inner lumen extending therethrough between proximal and distal ends thereof, and upper and lower jaws located on the distal end and movable relative to one another for cutting tissue. A tissue collector is coupled to the proximal end of the

elongate shaft and is in fluid communication with the inner lumen such that the tissue collector is effective to collect tissue cut by the upper and lower jaws. In one exemplary embodiment, the tissue collector can include a housing having a collecting module disposed therein and configured to separate cut tissue from fluid. The collecting module can include indicia to measure the amount of cut tissue. The collecting module can have a variety of configurations, and it can be configured to collect cut tissue therein, or to collect cut tissue on an external surface thereof. In one embodiment, the collecting module can be a mesh bag. The tissue collector can be removably coupled to the elongate shaft. The upper and lower jaws can also include additional features. For example, at least one aspirating hole in fluid communication with the inner lumen can be formed in at least one of the upper jaw, the lower jaw, and the elongate shaft. At least one tissue cutting surface feature can also be formed on at least one of the upper and lower jaws.

In another embodiment, a spinal disc preparation tool is provided and includes an elongate shaft having an inner lumen extending therethrough between proximal and distal ends thereof, and a lower jaw associated with a distal end of the elongate shaft. An upper jaw is movably coupled to the distal end of the elongate shaft and it is adapted to move relative to the lower jaw to cut tissue. At least one tissue cutting surface feature is formed on at least one of the upper and lower jaws. The tissue cutting surface feature can be configured in a variety of ways, such as to remove tissue along a surface of a vertebral endplate or to cut into a surface of an endplate. The surface feature can also be formed in a number of ways. For example, the at least one tissue cutting surface feature can be in the form of a rasp formed on an exterior surface of the lower jaw, a curette formed on an exterior surface of the lower jaw, a tooth formed on opposed sides of the upper and lower jaws, or a protrusion formed on an exterior surface of the lower jaw and having a concavity for scraping tissue.

Methods for cutting tissue are also provided, and in one embodiment the method can include inserting a distal end of an elongate shaft of a spinal disc preparation tool between adjacent vertebrae, and actuating an upper jaw on the distal end of the elongate shaft to move the upper jaw relative to a lower jaw on the distal end of the elongate shaft to cut tissue between the adjacent vertebrae. The cut tissue is aspirated through an inner lumen extending through the elongate shaft, and the tissue is separated from fluid and collected by a tissue collector in fluid communication with the inner lumen.

#### BRIEF DESCRIPTION OF THE DRAWINGS

The invention will be more fully understood from the following detailed description taken in conjunction with the accompanying drawings, in which:

FIG. 1 is a side view of a spinal disc preparation tool having a distal end with upper and lower jaws for cutting tissue;

FIG. 2 is a perspective view of the spinal disc preparation tool of FIG. 1 showing an upper pusher coupled to the upper jaw and a lower tube coupled to the lower jaw;

FIG. 3 is a side view of another embodiment of a spinal disc preparation tool having an elongate shaft with a pre-bent distal end;

FIG. 4A is a side view of another embodiment of a spinal disc preparation tool having an elongate shaft with a distal portion that articulates;

FIG. 4B is a side view of another embodiment of a spinal disc preparation tool having an elongate shaft with a distal portion that articulates;

FIG. 5A is a side view of another embodiment of a spinal disc preparation tool having an elongate shaft with a distal portion that is flexible;

FIG. 5B is a cross-sectional view of a lower tube of the elongate shaft of FIG. 5A;

FIG. 5C is a side view of a pusher member of an upper pusher of the elongate shaft of FIG. 5A;

FIG. 6A is a cross-sectional view taken along line B-B of the distal end of a tissue-receiving cavity defined by the upper and lower jaws shown in FIG. 1;

FIG. 6B is a cross-sectional view taken along line A-A of the distal opening of an inner lumen defined by an elongate shaft of the tool shown in FIG. 1;

FIG. 6C is a cross-sectional view taken along lines C-C, D-D, and E-E of the inner lumen of the elongate shaft shown in FIG. 1;

FIG. 6D is a cross-sectional view taken along line F-F of a proximal opening of the inner lumen of the elongate shaft shown in FIG. 1;

FIG. 7A is a side view of another embodiment of an upper jaw for use with a spinal disc preparation tool, the jaw having a removable and replaceable hood with a blade coupled to an outer surface thereof;

FIG. 7B is a side view of the hood of FIG. 7A;

FIG. 8A is a side view of another embodiment of an upper jaw for use with a spinal disc preparation tool, the jaw having a removable and replaceable insert with a blade coupled to an inner surface thereof;

FIG. 8B is a side view of the insert of FIG. 8A;

FIG. 8C is a perspective view of the insert positioned within the upper jaw of FIG. 8A;

FIG. 9 is a perspective view of one embodiment of a portion of an elongate shaft for use with a spinal disc preparation tool having a removable and replaceable distal end showing upper and lower attachment means to couple proximal and distal portions of the upper pusher and the lower tube together;

FIG. 10 is a top view of another embodiment of a portion of an elongate shaft for use with a spinal disc preparation tool showing a removable and replaceable distal end;

FIG. 11 is a side view of a portion of a handle of the tool of FIG. 1 having one embodiment of an aspiration hole formed therein;

FIG. 12A is a side view of a portion of a handle of the tool of FIG. 1 showing another embodiment of an aspiration hole formed therein;

FIG. 12B is a top view of the tool of FIG. 12A showing the aspiration hole formed therein;

FIG. 13 is a side view of upper and lower jaws of the tool of FIG. 1 with a single aspiration hole in each of the upper and lower jaws;

FIG. 14A is a side view of upper and lower jaws of the tool of FIG. 1 with a single aspiration hole in the upper jaw and multiple aspiration holes in the lower jaw;

FIG. 14B is a cross-sectional view of another embodiment upper and lower jaws of the tool of FIG. 1 having multiple aspiration holes formed therein;

FIG. 15 is a cross-sectional view of another embodiment of upper and lower jaws for use with a spinal disc preparation tool showing the upper jaw having an increased width to minimize cutting of bone surrounding the tissue being cut by the upper and lower jaws;

5

FIG. 16A is a front view of one embodiment of upper and lower jaws having a septum disposed in the lower jaw for dissecting cut tissue;

FIG. 16B is a side view of a rasp formed on the lower jaw of FIG. 16A for preparing a vertebral endplate;

FIG. 16C is a perspective view of the upper and lower jaws of FIG. 16A having the septum and a septum receiver for cutting tissue;

FIG. 17A is a front view of one embodiment of upper and lower jaws including a curette for preparing a vertebral endplate;

FIG. 17B is a side view of the jaws and curette of FIG. 17A;

FIG. 18A is a front view of another embodiment of upper and lower jaws including a protrusion and end abraders for preparing a vertebral endplate;

FIG. 18B is a side view of the jaws, protrusion, and end abraders of FIG. 18A;

FIG. 19A is a side view of one embodiment of a tissue collector adapted to couple to a spinal disc preparation tool and having a collector module adapted to collect cut tissue therein;

FIG. 19B is a perspective view of the collector module of FIG. 19A including indicia thereon for measuring an amount of cut tissue;

FIG. 20A is a side view of another embodiment of a tissue collector adapted to couple to a spinal disc preparation tool and having a collector module adapted to collect cut tissue on an external surface thereof;

FIG. 20B is a perspective view of the collector module of FIG. 20A including indicia thereon for measuring an amount of cut tissue collected on the outside of the collector module;

FIG. 21 is a perspective view of one embodiment of a collector module for use with a tissue collector; and

FIG. 22 is a perspective view of another embodiment of a collector module for use with a tissue collector.

#### DETAILED DESCRIPTION OF THE INVENTION

Certain exemplary embodiments will now be described to provide an overall understanding of the principles of the structure, function, manufacture, and use of the devices and methods disclosed herein. One or more examples of these embodiments are illustrated in the accompanying drawings. Those of ordinary skill in the art will understand that the devices and methods specifically described herein and illustrated in the accompanying drawings are non-limiting exemplary embodiments and that the scope of the present invention is defined solely by the claims. The features illustrated or described in connection with one exemplary embodiment may be combined with the features of other embodiments. Such modifications and variations are intended to be included within the scope of the present invention.

The present invention provides various methods and devices for preparing an intervertebral disc space. A person skilled in the art will appreciate that the methods and devices described herein can also be used for the removal of soft tissue, muscle, fascia, or ligaments prior to entering the disc space. In general, a spinal disc preparation tool is provided that is adapted to cut tissue between an upper and lower jaw at a distal end of the tool. FIG. 1 illustrates one exemplary embodiment of a spinal disc preparation tool 10 that generally includes an elongate shaft 12 having an inner lumen extending therethrough along a longitudinal axis between a proximal end 12p and a distal end 12d of the elongate shaft 12. The elongate shaft 12 includes upper and lower jaws 16,

6

18 associated with the distal end 12d thereof, and a port 14 associated with the proximal end 12p thereof that is adapted to facilitate aspiration of tissue through the inner lumen of the elongate shaft 12. In one embodiment, the lower jaw 18 can be located on or formed in the distal end 12d of the elongate shaft 12, and the upper jaw 16 can be movably coupled to the distal end 12d of the elongate shaft 12 to allow the upper jaw 16 to move relative to the lower jaw 18 to cut tissue therebetween, for example, with a shearing motion. The upper and lower jaws 16, 18 can define a tissue-receiving cavity therebetween for receiving the cut tissue.

The elongate shaft 12 can have a variety of configurations, and it can be rigid or flexible depending on the intended use. In an exemplary embodiment, the elongate shaft 12 is adapted to be positioned within a body cavity and thus can have a length sufficient to allow the distal end 12d of the shaft 12 to be positioned within the body while the proximal end 12p remains external to the body to allow a user to grasp a handle 20 and operate an actuator 22 extending from the proximal end 12p of the elongate shaft 12. While the elongate shaft 12 can be formed from a single shaft having the inner lumen disposed therethrough, the elongate shaft 12 can also optionally be formed from a lower tube 100 having an inner lumen disposed therethrough and the lower jaw 18 disposed on a distal end thereof, and an upper pusher 102 having the upper jaw 16 disposed on a distal end thereof. The upper pusher 102 can be configured to move back and forth longitudinally along the lower tube 100 to open and close the upper jaw 18 to cut tissue. The lower tube 100 and the upper pusher 102 can be coupled in a variety of ways. For example, the upper pusher 102 can include a plurality of slots 104 formed therein that receive a plurality of pins 106 formed on the lower tube. In the illustrated embodiment shown in FIG. 2, the upper pusher 102 and the lower tube 100 include two slots 104 and two pins 106, respectively. The pins 106 are configured to sit within the slots 104 to couple the upper pusher 102 and the lower tube 100 together, but the pins 106 can also slide longitudinally within the slots 104 to allow the upper pusher 102 to move relative to the lower tube 100 to cause the upper jaw 18 to pivot relative to the lower jaw 18 in order to cut tissue, as will be discussed in more detail below. One skilled in the art will appreciate that the elongate shaft 12 can be made from a variety of biocompatible materials that have properties sufficient to enable the shaft 12 to be inserted and moved within the body.

The elongate shaft 12 can optionally include features to allow a distal portion of the elongate shaft 12 to reach a contralateral side of the vertebral disc space. In one embodiment, the distal end 12d of the elongate shaft 12' can be pre-bent to form an arc, as shown in FIG. 3. The distal end 12d' of the elongate shaft 12' can be arced in a variety of directions, but in the illustrated embodiment the distal end 12d' is arced such that it resides in substantially the same plane as the handle 20 of the tool 10. In another embodiment, the elongate shaft can include features to allow a distal portion of the elongate shaft to articulate to redirect the distal portion of the elongate shaft. In one exemplary embodiment as shown in FIGS. 4A-4B, the elongate shaft 12" can include an articulation joint 24" formed therein at a location proximal to the upper and lower jaws 16", 18". The articulation joint 24" can allow the portion of the elongate shaft 12" distal to the joint 24" to pivot side-to-side along a single plane, or in other embodiments along multiple planes, relative to the portion of the elongate shaft 12" proximal to the joint 24". Articulation can be controlled by a trigger, knob, or other actuation mechanism on the handle 20", or

actuation can be passively controlled by applying a force to the distal portion, e.g., with tissue. A person skilled in the art will appreciate that various articulation mechanisms known in the art can be used to allow articulation of the distal portion of the elongate shaft. While not shown, the elongate shaft can also optionally be configured to rotate relative to the handle, and various rotation mechanisms known in the art can be used.

In another exemplary embodiment shown in FIGS. 5A-5C, the distal portion of the elongate shaft can be flexible. For example, the lower tube 100' of the elongate shaft 113 can include a plurality of male connectors 121 configured to couple to a plurality of female connectors 123 formed on the upper pusher 102'. The upper pusher 102' can be formed from a plurality of individual pusher members 125 with each pusher member 125 having a single female connector 123 formed thereon to connect to the male connectors 121 of the lower tube 100'. The use of individual pusher members 125 allows the upper pusher 102' to bend during articulation as gaps can form between the individual pusher members 125. The articulation of the distal portion 113d of the elongate shaft 113 can be controlled by an actuation member disposed on the proximal end 113p of the elongate shaft 113, such as a lever 120 shown in FIG. 5A. A person skilled in the art will appreciate that the actuation member can have any configuration or shape that is capable of controlling the articulation of the distal portion 113d of the elongate shaft 113. In one exemplary embodiment, one or more guidewires 122 can extend from attachment portions on the distal portion of the elongate shaft 113 to the lever 120. In the illustrated embodiment shown in FIG. 5A, there are three attachment points 124a, 124b, 124c that attach the guidewire 122 to the distal portion of the elongate shaft 113. The lever 120 can pivot about a pivot pin 126 disposed through the lever 120, causing tensioning and/or relaxing of the guidewire 122 to articulate the distal portion of the elongate shaft 113.

The upper and lower jaws 16, 18 associated with the distal end 12d of the elongate shaft 12 can also have a variety of configurations. In the illustrated embodiment, the lower jaw 18 has a generally elongate shape that extends distally from the distal end 12d of the elongate shaft 12. The lower jaw 18 can be formed from a concavity formed in the elongate shaft 12 that is adapted to receive cut tissue, or the lower jaw 18 can be a separate component that is fixedly or removably attached to the distal end 12d of the elongate shaft 12. A person skilled in the art will appreciate that the lower jaw 18 can be attached to the elongate shaft 12 in any manner that allows the lower jaw 18 to remain fixed relative to the elongate shaft 12 during cutting of tissue. In other embodiments, the upper and/or lower jaws 16, 18 can be removable and replaceable to allow jaws having various configurations to be selectively attached to the tool 10, as will be discussed in more detail below.

The upper jaw 16 can be pivotally coupled to the distal end 12d of the elongate shaft 12 and/or to the lower jaw 18, and it can be adapted to pivot relative to the lower jaw 18 and the elongate shaft 12 in order to cut tissue. The upper jaw 16 can have a variety of configurations, but in the illustrated embodiment the upper jaw 16 has a generally elongate shape with a concavity formed therein for receiving the cut tissue. The concave configuration of the upper and lower jaws 16, 18 together can form a tissue-receiving cavity that is configured to receive the cut tissue. The tissue-receiving cavity can have a variety of configurations, but in the illustrated embodiment is generally in the form of an oval-shaped cavity between the upper and lower jaws 16, 18.

One exemplary embodiment of a tissue-receiving cavity 30 defined between the upper and lower jaws 16, 18 is illustrated in FIG. 6A. The cross-sectional area of the tissue-receiving cavity 30 can be chosen in order to improve the aspiration of the cut tissue. In one exemplary embodiment, as shown in FIG. 6A, the tissue-receiving cavity 30 can have a maximum cross-sectional area that is less than a cross-sectional area of the inner lumen of the elongate shaft 12, at least at the distal opening of the inner lumen shown in FIG. 6B. The reduced cross-sectional area of the tissue-receiving cavity can control the size of the cut tissue therein and thus the size of the tissue that passes into the inner lumen. Such a configuration can thus improve aspiration by ensuring that the cut tissue has a size that is less than the size of the inner lumen to allow the tissue to easily fit within the inner lumen. In certain exemplary embodiments, the cross-sectional area of the tissue-receiving cavity 30 can be about 50% less than the cross-sectional area of the inner lumen at the distal opening of the inner lumen. A person skilled in the art will appreciate, however, that the cross-sectional area of the tissue-receiving cavity 30 can be any amount less than the cross-sectional area of the inner lumen to improve aspiration of the cut tissue. Additionally, the cross-sectional area of the inner lumen can increase from the distal end to the proximal end of the inner lumen, as shown in FIG. 6C, to also improve aspiration of the cut tissue by increasing the size of the inner lumen as the tissue moves proximally through the tool 10. For example, the cross-sectional area at the proximal end of the inner lumen can be about twice the cross-sectional area of the distal end of the inner lumen. A person skilled in the art will appreciate, however, that any increase in the cross-sectional area of the inner lumen from the distal end to the proximal end thereof will act to increase the effectiveness of the aspiration of the cut tissue through the inner lumen. FIG. 6D illustrates the cross-sectional area of the proximal end of the tool, which is preferably large enough to accommodate the cut tissue received from the inner lumen of the elongate shaft 12.

As discussed above, the upper and lower jaws 16, 18 can also be removable and replaceable to facilitate cutting tissue therebetween. For example, the upper jaw 16 and/or the lower jaw 18 can include removable and/or disposable cutting blades such that the blades can be removed from the upper jaw 16 and/or lower jaw 18 and replaced after multiple uses have dulled the sharpness of the blades to facilitate cutting tissue. In one exemplary embodiment, shown in FIGS. 7A-7B, the upper jaw 216 includes a removable hood 260 that has an elongate concave shape that is sized and shaped to fit around an outer surface of the upper jaw 216. The hood 260 includes a blade 262 formed on a first end 260a thereof that is adapted to cut tissue. The hood 260 can be configured to couple to the upper jaw 216 in a variety of ways, but in the illustrated embodiment the hood 260 includes first and second openings 264 formed on opposed sides of a second end 260b of the hood 260 that correspond to first and second protrusions 266 formed on opposed sides of the upper jaw 216. The first and second openings 264 are configured to removably receive the first and second protrusions 266 of the upper jaw 216 to removably couple the hood 260 to the upper jaw 216. A person skilled in the art will appreciate, however, that the hood 260 can be coupled to the outer surface of the jaw using any technique known in the art. Moreover, a person skilled in the art will appreciate that the lower jaw can also include a removable hood with a cutting blade configured to fit around an outer surface of the lower jaw, used alone or in combination with the hood 260 on the upper jaw 216.

In another exemplary embodiment, shown in FIGS. 8A-8C, the upper jaw 316 can include a removable insert 370 that has an elongate concave shape that is sized and shaped to fit in an inner surface of the upper jaw 316. The insert 370 includes a blade 372 formed along a lower edge thereof that is configured to cut tissue. The insert 370 can be configured to couple to the inner surface of the upper jaw 316 in a variety of ways, but in the illustrated embodiment the insert 370 includes a protrusion 374 that is configured to fit within an opening 376 formed in the inner surface of the upper jaw 316. The protrusion 374 and the opening 376 can couple together in a variety of ways. For example, the protrusion 374 can be tapered such that the end of the protrusion 374 that is attached to the insert 370 is narrower than the end that is inserted into the opening 376 in the upper jaw 316. The protrusion 374 can be press-fit into the opening 376 such that the protrusion 374 deforms upon insertion into the opening 376, and then once fully inserted returns to its original state whereby the protrusion 374 extends into the opening 376 and the wider end of the tapered protrusion 374 holds the protrusion 374 within the opening 376. A person having ordinary skill in the art will appreciate that a variety of mechanisms can be used to secure the protrusion 374 of the insert 370 within the opening 376 formed in the upper jaw 316, and that any number of corresponding protrusions and openings can be used. Moreover, a person skilled in the art will appreciate that the lower jaw can also include a removable insert with a cutting blade configured to fit in an inner surface of the lower jaw, used alone or in combination with the insert 370 in the inner surface of the upper jaw 316.

In yet another exemplary embodiment, shown in FIG. 9, a distal portion of the elongate shaft 412 and the upper and lower jaws can be removable and replaceable. While the removable distal portion 80 of the elongate shaft 412 can be coupled to the proximal portion 82 of the elongate shaft 412 in a variety of ways, in the illustrated embodiment a lower attachment means 84 is configured to couple the proximal and distal portions 80, 82 of the lower tube of the elongate shaft 12, and an upper attachment means 86 is configured to couple the proximal and distal portions 80, 82 of the upper pusher of the elongate shaft 412. The lower and upper attachment means 84, 86 can have various configurations, but in the embodiment shown in FIG. 9, the lower attachment means 84 is in the form of first and second arms 85a, 85b extending from the proximal end of the distal portion 80 of the lower tube along the longitudinal axis thereof. The arms 85a, 85b include first and second protrusions 87a, 87b formed on the outer surfaces of the arms 85a, 85b. The proximal portion 82 of the lower tube includes first and second holes 88 formed in opposed lateral sides thereof that are configured to receive the protrusions 87a, 87b of the arms 85a, 85b of the distal portion 80 of the lower tube. The holes 88 are positioned along the proximal portion of the lower tube such that the proximal end of the distal portion of the lower tube abuts the distal end of the proximal portion of the lower tube when the protrusions 87a, 87b of the arms 85a, 85b are inserted into the holes 88. To couple the portions of the lower tube, the arms 85a, 85b are pressed towards one another and inserted into the distal end of the proximal portion of the lower tube. The arms 85a, 85b of the distal portion of the lower tube are pushed into the proximal portion of the lower tube until the protrusions 87a, 87b reach and move into the holes 88, thus temporarily locking the portions of the lower tube together. To remove the distal portion of the lower tube, the protrusions 87a, 87b are pressed into the holes 88 and the distal portion of the lower tube is moved distally until the arms 85a, 85b are free from

the proximal portion of the lower tube. The upper attachment means 86 is in the form of a first arm 89 extending from the distal portion of the upper pusher and a second arm 90 extending from the proximal portion of the upper pusher. The first and second arms 89, 90 each have a bore 92, 94 formed therethrough such that when the first and second arms 89, 90 are lined up adjacent one another, the bores 92, 94 line up to form a single bore through both the first and second arms 89, 90. A locking mechanism, such as a screw 96, can be inserted through the bores 92, 94 and locked to the first and second arms 89, 90 using a locking nut 98. To remove the distal portion of the upper pusher, the locking nut 98 is unscrewed from the locking mechanism and the locking mechanism is removed from the bores 92, 94 of the first and second arms 89, 90 to allow the first and second arms 89, 90 to be separated.

In another exemplary embodiment shown in FIG. 10, the upper and lower attachment means can be in the form of connectors 510 configured to couple the proximal and distal portions 580, 582 of the elongate shaft 512. In the illustrated embodiment, the distal portion 580 includes a connector 513 in the form of an elongate protrusion extending from a proximal end of the distal portion 580 and having an enlarged head on a proximal end thereof. The connector 513 can be removably disposed within a corresponding bore 514 formed in the proximal portion 582 of the elongate shaft 512. The bore 514 can have a shape that corresponds to the shape of the connector 513 to allow the connector 513 to be inserted to and removably couple thereto. The connector 513 can have a slot or cut-out 516 formed therein that allows the connector 513 to deform upon insertion into the bore 514 and to expand once fully inserted to engage the bore 514. To remove the connector 513 from the bore 514, tension or rotation can be applied to overcome the snap-fit between the connector 513 and the bore 514. A person skilled in the art will appreciate, however, that any type of removable connection between the proximal and distal portions of the elongate shaft can be used to removably and replaceably mate the distal portion to the proximal portion.

Referring back to FIGS. 1 and 2, as indicated above, the proximal end 12p of the elongate shaft 12 can include a handle 20 coupled thereto. The handle 20 can have any shape and size, but it is preferably adapted to facilitate grasping and manipulation of the tool 10. The handle 20 can include an actuator coupled thereto that can have a variety of configurations to control movement of the upper jaw 16 relative to the lower jaw 18. In one embodiment, the actuator 22 is a trigger that is pivotally coupled to the housing 20 and that is operatively connected to a proximal end of the upper pusher 102. A distal end of the upper pusher 102 is coupled to a proximal end of the upper jaw 16, for example, using one or more pivot pins to couple the upper jaw 16 and the upper pusher 102 together to allow the upper jaw 16 is to pivot relative to the upper pusher 102 and the lower tube 100. In the illustrated embodiment, the actuator 22 pivots about a pivot point toward and away from the handle 20 to move the upper pusher 102 proximally and distally. Movement of the actuator 22 towards the handle 20 causes the upper pusher 102 to move distally and push the upper jaw 16 distally, causing the upper jaw 16 to pivot relative to the lower jaw 18 and cut tissue therebetween. Releasing the actuator 22 causes the upper pusher 102 to move proximally and pull the upper jaw 16 proximally, causing the upper jaw 16 to pivot away from the lower jaw 18. A person skilled in the art will appreciate that the actuator 22 can be operatively associated with the upper jaw 16 in any form that facilitates the movement of the upper jaw 16. While the illustrated

11

embodiment shows the actuator **22** in the form of a trigger, a person skilled in the art will appreciate the actuator **22** can have a variety of configurations, including but not limited to a button, a knob, a switch, or any other member that can be adapted to facilitate movement of the upper jaw **16**. While not shown, a spring can optionally be used to bias the actuator **22**, either toward and or away from the handle **20**. For example, movement of the actuator **22** can cause a spring disposed in the handle **20** to compress and move the upper pusher **102** distally to move the upper jaw **16** towards the lower jaw **18** by pushing the upper jaw **16** distally. Releasing the actuator **22** can cause the spring to release and move the upper pusher **102** proximally to move the upper jaw **16** away from the lower jaw **18** by pulling the upper jaw **16** proximally and pivoting the upper jaw **16** away from the lower jaw **18**.

The tool **10** can include various additional features to aid in the aspiration of the cut tissue. In one exemplary embodiment, the handle **20** can include one or more aspiration holes formed therein and in fluid communication with the inner lumen of the elongate shaft **12**. The aspiration hole can aid in aspiration of the tissue through the inner lumen of the elongate shaft **12** by helping to facilitate the formation of a vacuum within the inner lumen and thus increase the effectiveness of the aspiration when the aspiration hole is blocked. The aspiration hole can be located in a variety of positions on the handle **20**. In one exemplary embodiment shown in FIG. **11**, the aspiration hole **40** can be located on the handle **20** such that when the actuator **22** is unactivated the hole remains open, and when the actuator **22** is activated the hole is blocked. For example, in the illustrated embodiment the aspiration hole **40** is positioned on the handle **20** at a location just distal to a proximal end of the actuator **22**. As the actuator **22** is actuated, the proximal end of the actuator **22** will move distally to block the aspiration hole **40**. In another exemplary embodiment, shown in FIGS. **12A-12B**, an aspiration hole **42** can be located on the handle **20** in a position that allows the user to block the aspiration hole **42** manually, for example, with a portion of the user's hand, such as a finger. For example, the aspiration hole **42** can be located on a housing **43** in communication with the inner lumen and formed on the tool **10** at a location adjacent to the handle **20** to allow the hole **42** to be covered manually while grasping the handle **20**. While FIGS. **11-12B** illustrate a single aspiration hole **40**, **42**, a person skilled in the art will appreciate that any number of aspiration holes can be formed in the handle **20** or anywhere along the length of the tool **10** as long as they can be blocked with a component of the tool **10** or manually by the user. In addition, a person skilled in the art will also appreciate that the tool **10** can include multiple aspiration holes and the aspiration hole(s) can have any size and shape as long as it can be blocked with a component of the tool **10** or manually by the user.

Additional features to facilitate aspiration of the cut tissue can be formed on the upper and lower jaws. In one exemplary embodiment, one or more aspiration holes, shown in FIGS. **13-14B**, can be formed in either or both of the upper and lower jaws **616**, **618**. The one or more aspiration holes can allow ambient gases and/or fluid to flow therethrough to aid in removing the tissue from the tissue-receiving cavity **630** and into the inner lumen of the elongate shaft **612**. The aspiration holes can be formed in various locations on the upper and lower jaws **616**, **618**. FIG. **13** illustrates one embodiment of upper and lower jaws **616**, **618** including a single aspiration hole **44a** formed in a middle portion of the upper jaw **616**, and single aspiration hole **44b** formed in the distal end of the lower jaw **618**. FIG. **14A** illustrates another

12

exemplary embodiment in which the upper jaw **616** includes a single aspiration hole **45a** formed in a middle portion of the upper jaw **616**, however the lower jaw **618** includes a first aspiration hole **45b** formed in a distal portion of the lower jaw **618** and a second aspiration hole **45c** formed in a proximal portion of the lower jaw **618**. FIG. **14B** illustrates yet another embodiment in which the upper jaw **616** includes a single aspiration hole **46a** formed in a middle portion of the upper jaw **616**, and the lower jaw **618** includes first and second aspiration holes **46b**, **46c** formed therein. In this embodiment, the aspiration holes **46b**, **46c** in the lower jaw **618** are formed in opposed lateral sides thereof and they extend at an angle relative to one another. A person skilled in the art will appreciate, however, that any number of holes can be found in either or both of the upper and lower jaws **616**, **618** to aid in aspiration.

In another exemplary embodiment, the upper jaw **716** can have a size and shape that is configured to minimize the amount of bone that is scraped by the upper and lower jaws **716**, **718** during cutting of the tissue as the bone can clog the tissue-receiving cavity and inner lumen of the elongate shaft. While the upper jaw **716** can have many configurations, in the embodiment illustrated in FIG. **15**, an upper portion of the upper jaw **716** has an increased width  $W_{upper}$  such that a maximum width of the upper jaw **716** is equal to a maximum width  $W_{lower}$  of the lower jaw **718** to minimize scraping of bone surrounding the upper and lower jaws **716**, **718**. For example, when the upper and lower jaws **716**, **718** are used to remove tissue along a surface of a vertebral endplate, the width of the upper jaw **716** can hold the vertebral endplates apart by a distance that is equal to the width of the lower jaw **718**. As a result, the risk of scraping the endplates while opening and closing the jaws will be prevented or decreased. A person skilled in the art will appreciate that the upper jaw **716** can have any size and shape that can prevent cutting and scraping of bone as tissue is being cut.

In another exemplary embodiment, either of the upper and lower jaws **16**, **18** can include features to decrease the size of the cut tissue to allow for easier passage from the tissue-receiving cavity to the inner lumen of the elongate shaft **12**. While this feature can have many configurations, in the embodiment illustrated in FIG. **16A**, a septum **46** can be formed in the upper jaw **16** and it can be configured to dissect the cut tissue to facilitate aspiration. The septum **46** can be in the form of an elongate wall or divider extending downwards from the inner surface of the upper jaw **16** and positioned substantially at a midpoint of the upper jaw **16** to facilitate the dissection of the tissue. A person skilled in the art will appreciate that the upper jaw **16** can include more than one elongate wall or divider in order to cut the tissue into even smaller pieces. In another exemplary embodiment, the lower jaw **18** can include a septum receiver **47** for use with the septum **46** to cut tissue. The septum receiver **47** can have a variety of configurations, but in the embodiment illustrated in FIG. **16C**, the septum receiver **47** is in the form of an elongate projection extending longitudinally along a midpoint of the inner surface of the lower jaw **18**. The septum **46** and the septum receiver **47** are positioned opposite one another such that the two components abut, or the septum **46** is received within a groove or channel in the septum receiver **47**, to cut tissue therebetween when the upper jaw **16** is moved toward the lower jaw **18**. As shown in FIG. **16B**, the upper jaw **16** can include a tip **61**.

In yet another exemplary embodiment, either or both of the upper and lower jaws **16**, **18** can include a coating, laminate, sheath, or other covering formed on an inner

13

surface thereof for aiding in the aspiration of cut tissue through the inner lumen. The coating can be formed from a variety of materials, including but not limited to hydrophilic coatings to lubricate the upper and/or lower jaws **16, 18** and hydrophobic coatings such that the coating repels fluid and prevents adhesion of the cut tissue to the inner surface of the upper and/or lower jaws **16, 18**. A person skilled in the art will appreciate that any coating, laminate, or sheath can suffice that can facilitate movement of the cut tissue out of the upper and lower jaws **16, 18** and into the inner lumen of the elongate shaft **12**. A person skilled in the art will also appreciate that any of the aspiration aides described above can be used in any combination to aid in the aspiration of cut tissue into and through the inner lumen of the elongate shaft **12**.

The upper and lower jaws **16, 18** can also include tissue cutting surface features that can be configured to prepare a vertebral endplate for insertion of an implant between adjacent vertebrae after the removal of the cut tissue. For example, the tissue cutting surface features can be configured to remove tissue along a surface of a vertebral endplate, or they can be adapted to cut into the surface of the vertebral endplate. The tissue cutting surface features can be formed on either or both of the upper and lower jaws **16, 18** and on any location of the jaws **16, 18** in order to facilitate preparation of the endplate. The tissue cutting surface features can also have a variety of configurations. In one exemplary embodiment shown in FIGS. **16A-16B**, the tissue cutting surface features are in the form of a rasp **60**. The rasp **60** can include a plurality of teeth adapted to remove tissue and cut into the surface of the vertebral endplate. The rasp **60** can include any number of teeth, and the teeth can be formed on any location of the lower jaw **18**, although in the illustrated embodiment the teeth are formed on an exterior lower surface thereof. In another exemplary embodiment shown in FIGS. **17A-17B**, the tissue cutting surface features are in the form of a curette **64** formed on an exterior surface of the lower jaw **18**. The curette **64** is in the form of a cylindrical protrusion **66** formed on the lower jaw **18** that is adapted to cut and/or scrape tissue from vertebral endplates. The protrusion **66** can include an opening **68** therethrough that is in fluid communication with the tissue-receiving cavity formed by the upper and lower jaws **16, 18** to allow the tissue that is cut and/or scraped from the endplate to be aspirated through the tissue-receiving cavity and into the inner lumen of the elongate shaft **12**. In another exemplary embodiment, the tissue cutting surface features can be in the form of a protrusion formed on an exterior surface of the lower jaw **18** and adapted to push or pull tissue on the vertebral endplate depending on the shape and angle of the protrusion, as shown in FIGS. **18A-18B**. The protrusion **70** is angled away from the distal end of the lower jaw **18** and can thus also scoop the tissue scraped off the vertebral endplate. The upper and lower jaws **16, 18** can also include additional tissue cutting surface features formed at any location thereon. For example, as shown in FIG. **18A**, the upper and lower jaws **16, 18** can include one or more **72** edge abraders formed on opposed lateral sides of the upper and lower jaws **16, 18**. A person skilled in the art will appreciate that any type of tissue cutting surface features can be formed on the upper and/or lower jaws **16, 18** at any location thereon for preparing vertebral endplates.

In use, the tool **10** can be connected to an aspiration device, for example, by connecting the port **14** to a vacuum that can be activated manually or automatically controlled to aspirate the cut tissue from the tissue-receiving cavity through the inner lumen and out the proximal end of the tool

14

**10**. A person skilled in the art will appreciate, however, that the cut tissue can also be passed through the inner lumen without an aspiration device. For example, subsequently cut tissue can push previously cut tissue out of the tissue-receiving cavity and into the inner lumen. The movement of the tissue from the tissue-receiving cavity between the upper and lower jaws through the inner lumen of the elongate shaft can be facilitated by the use of a reduced cross-sectional area in the tissue-receiving cavity, as well as with the additional optional features described above to improve aspiration of the tissue.

The tool **10** can also optionally include features to aid in the collection of the tissue cut by the upper and lower jaws **16, 18**. In one exemplary embodiment, the tool **10** can include a tissue collector **50** that can be coupled to the proximal end of the elongate shaft **12** and that can be in fluid communication with the inner lumen of the elongate shaft **12** such that the tissue collector **50** is effective to collect tissue that is cut by the upper and lower jaws **16, 18**. The tissue collector **50** can have a variety of configurations, but in one embodiment shown in FIGS. **19A** and **20A** it can include a housing **52** adapted to couple to the proximal end **12p** of the elongate shaft **12**. The housing **52** can include an inlet **53** to allow for fluid communication with the inner lumen of the elongate shaft **12**, and an outlet **55** to allow for fluid collected in the tissue collector **50** to exit the housing **52**. The tissue collector **50** can be coupled to the elongate shaft in a variety of ways. For example, the tissue collector **50** can be removably coupled to the elongate shaft **12**, or the tissue collector can be unitary with the elongate shaft **12**. While the illustrated embodiment shows a tissue collector **50** configured to couple to the shaft **12** with an in-line configuration, the tissue collector **50** can be located at numerous locations, including separate from the elongate shaft **12** as long as the tissue collector **50** remains in fluid communication with the inner lumen of the elongate shaft **12**. In the illustrated embodiment, the tissue collector **50** includes an elongate member **57** that is configured to interlock with an exit port on the inner lumen of the tool **10**. The housing **52** can be removably mated to a cap **54** on the elongate member **57** having an o-ring therein. The elongate member **57** can be part of the tool **10**, for example, by being formed on the proximal end **12p** of the elongate shaft **12**, or the elongate member **57** can be a separate component that is removably matable to the elongate shaft **12** and/or the housing **52**.

The housing **52** can also include a collecting module **58** disposed therein for collecting the cut tissue and separating the cut tissue from other material, such as fluid, that may pass through the inner lumen of the elongate shaft **12**. The collector module **58** can be configured to collect tissue in various configurations. In one exemplary embodiment, the collector module **58** can be configured to collect cut tissue therein, as illustrated in FIGS. **19A** and **19B**. The collector module **58** can thus be configured to be in fluid communication with the inner lumen of the elongate shaft to allow the tissue to travel through the inner lumen and into the collector module **58** through the open end of the collector module **52**. The fluid can pass from the collector module **58** into the housing **52** to separate the fluid from the cut tissue, and can exit the housing **52** through the outlet. In another exemplary embodiment, a collector module **58'** can be configured to collect tissue on an external surface thereof, as illustrated in FIGS. **20A** and **20B**. The collector module **58'** can thus be configured such that the housing **52** is in fluid communication with the inner lumen of the elongate shaft **12** and receives cut tissue and fluid therefrom. The tissue will collect on the outside of the collector module **58'** while the

15

fluid will pass from the housing **52** into the collector module **58'** to separate the fluid from the cut tissue, and can then exit the collector module **58'** through the outlet formed in the housing **52**. Various techniques can be employed to collect the cut tissue. For example, the cut tissue can be collected by removing it from the outside of the collector module **58'** or the cut tissue can be collected by inverting the collector module **58'** to contain the cut tissue therein.

The collecting module **58** can have any shape and size adapted to fit inside the housing **52** and collect tissue, and it can be made from any material that facilitates collection of the cut tissue while allowing any fluid to be separated therefrom. For example, the collecting module **58** can be in the form of a mesh bag having an open end with the mesh including holes therein that are sized and shaped to allow fluid but not the cut tissue to pass therethrough. In order to increase the surface area of the collecting module **58** to increase the amount of tissue that can be collected therein or thereon, the collecting module **58** can have a variety of cross-sectional shapes. FIGS. **21-22** illustrate various examples of cross sections of the collecting module **58** that can be used to increase the surface area across which fluid can flow, including an angled cross section shown in FIG. **21**, or a star-shaped cross-section shown in FIG. **22**. A person skilled in the art will appreciate that the collecting module can have any cross section that can facilitate passage of fluid therethrough, including but not limited to pleats or flutes.

The collecting modules **58** and **58'** can also include features adapted to measure the amount of cut tissue collected therein. For example, the collecting modules **58** can include indicia for measuring the amount of tissue collected therein, as shown in FIG. **19B**, or for measuring the amount of tissue collected on an external surface of the collecting module **58'**, as shown in FIG. **20B**.

The present invention also provides methods for cutting tissue. In one exemplary embodiment, the distal end of the elongate shaft **12** of the tool **10** can be inserted into the disc space between adjacent vertebrae for cutting the tissue therebetween, for example, a spinal disc which can be removed to be replaced with a spinal disc implant. The distal end of the elongate shaft can be positioned adjacent to the tissue to be cut such that the upper and lower jaws **16, 18** are placed adjacent the tissue. A distal portion of the elongate shaft **12** can also be articulated to help facilitate positioning of the upper and lower jaws **16, 18** relative to the tissue. The actuator **22** pivotally coupled to the handle **20** of the tool **10** can be actuated to cause the upper jaw **16** to move and pivot relative to the lower jaw **18** to cut tissue therebetween. Either using an aspiration device coupled to the tool **10**, the force of previously cut tissue pushing subsequently cut tissue, or both, the cut tissue is moved from the tissue-receiving cavity formed between the upper and lower jaws **16, 18** into the inner lumen of the elongate shaft **12**. The cut tissue moves proximally through the inner lumen until it either exits the proximal end of the tool **10** or is collected in the tissue collector **50** associated with a proximal end of the elongate shaft **12** and in fluid communication with the inner lumen. The cut tissue can be collected either inside or on the outside of the collector module housed inside the housing of the tissue collector, and can be measured if the collector module includes indicia thereon. As the tissue is being cut and removed, for example from the disc space between adjacent vertebrae, one or more tissue cutting surface features formed on the upper and/or lower jaws **16, 18** can be utilized to cut the vertebral endplates or scrape tissue

16

therefrom to prepare the endplates for insertion of a spinal disc implant into the disc space between the adjacent vertebrae.

One skilled in the art will appreciate further features and advantages of the invention based on the above-described embodiments. Accordingly, the invention is not to be limited by what has been particularly shown and described, except as indicated by the appended claims. All publications and references cited herein are expressly incorporated herein by reference in their entirety.

What is claimed is:

1. A spinal disc preparation tool, comprising:

an elongate shaft having an inner lumen extending there-through along a longitudinal axis between proximal and distal ends thereof;

a lower jaw located on a distal end of the elongate shaft for receiving tissue and delivering tissue to the inner lumen;

an upper jaw pivotally movable relative to the lower jaw; and

a handle coupled to a proximal end of the elongate shaft, the handle having formed therein an aspiration hole in fluid communication with the inner lumen;

wherein the aspiration hole is positioned such that the aspiration hole is blocked by a portion of a monolithic actuator handle when the actuator handle is actuated, the actuator handle being pivotally coupled to an actuator shaft coupled to the upper jaw for pivoting the upper jaw relative to the lower jaw; and

wherein the upper jaw includes one or more holes formed in a top surface thereof and the lower jaw includes one or more holes formed in a bottom surface thereof, the holes in the upper and lower jaws allowing gas to pass therethrough to aid in aspiration of cut tissue through the inner lumen.

2. The tool of claim 1, wherein the upper and lower jaws define a tissue receiving cavity having a maximum cross-sectional area taken transverse to the longitudinal axis that is less than a cross-sectional area of the inner lumen of the elongate shaft taken transverse to the longitudinal axis at a distal opening of the inner lumen, the cross-sectional area of the tissue-receiving cavity being about 50% less than the cross-sectional area of the inner lumen at the distal opening of the inner lumen.

3. The tool of claim 2, wherein the inner lumen has a cross-sectional area taken transverse to the longitudinal axis that increases from the distal opening to a proximal end of the inner lumen.

4. The tool of claim 3, wherein the cross-sectional area at the proximal end of the inner lumen is about twice the cross-sectional area at the distal opening of the inner lumen.

5. The tool of claim 1, wherein at least one of the upper jaw and lower jaw include an inner surface having a coating for aiding in aspiration of cut tissue through the inner lumen.

6. The tool of claim 5, wherein the coating is hydrophilic and provides a lubricated surface within at least one of the upper jaw and lower jaw.

7. The tool of claim 5, wherein the coating is hydrophobic such that the coating repels fluid and prevents adhesion of cut tissue to the upper jaw and lower jaw.

8. The tool of claim 1, wherein the actuator shaft extends along an external surface of the elongate shaft.

9. The tool of claim 1, further comprising a tissue collection housing coupled to the proximal end of the elongate shaft and in fluid communication with the inner lumen, the tissue collection housing having a tissue collector disposed therein and configured to separate cut tissue from fluid.

17

10. The tool of claim 1, further comprising at least one bone cutting element formed on at least one of the upper and lower jaws.

11. The tool of claim 1, further comprising a cutting septum formed in the upper jaw and configured to cut and separate cut tissue into two portions.

12. The tool of claim 1, wherein the elongate shaft includes an articulating joint formed therein for allowing angular articulation of the distal end of the shaft.

13. The tool of claim 1, wherein at least one of the upper and lower jaws has a first portion that is pivotally coupled to the elongate shaft or to the actuator shaft, and a second portion that is removably and replaceably coupled to the first portion, the second portion having a cutting blade formed thereon.

14. The tool of claim 1, wherein the upper jaw has a width that is equal to or greater than a width of the lower jaw.

15. The tool of claim 1, further comprising a tissue collection housing coupled to the proximal end of the elongate shaft and in fluid communication with the inner lumen, the tissue collection housing having a tissue collecting module disposed therein and effective to collect tissue cut by the upper and lower jaws, the tissue collection housing including indicia to measure the amount of cut tissue.

16. The tool of claim 1, further comprising a tissue collection housing coupled to the proximal end of the elongate shaft and in fluid communication with the inner lumen, the tissue collection housing having a tissue collecting module disposed therein and effective to collect tissue cut by the upper and lower jaws, the tissue collecting module comprising a mesh bag configured to collect cut tissue therein.

17. The tool of claim 1, further comprising a tissue collection housing coupled to the proximal end of the elongate shaft and in fluid communication with the inner lumen, the tissue collection housing having a tissue collecting module disposed therein and effective to collect tissue cut by the upper and lower jaws, the tissue collecting module comprising a mesh bag configured to collect cut tissue on an external surface thereof.

18. The tool of claim 1, further comprising a tissue collection housing coupled to the proximal end of the elongate shaft and in fluid communication with the inner lumen, the tissue collection housing having a tissue collecting module disposed therein and effective to collect tissue cut by the upper and lower jaws, the tissue collection housing being removably coupled to the elongate shaft.

19. The tool of claim 1, further comprising at least one tissue cutting surface feature formed on at least one of the upper and lower jaws.

20. A spinal disc preparation tool, comprising:

an elongate shaft having an inner lumen extending there-through along a longitudinal axis between proximal and distal ends thereof;

a lower jaw disposed on the distal end of the elongate shaft;

an actuator shaft extending along an external surface of the elongate shaft and coupled to an upper jaw for pivoting the upper jaw relative to the lower jaw, the upper jaw being movable relative to the lower jaw to cut tissue therebetween and deliver tissue to the inner lumen of the elongate shaft; and

a handle coupled to a proximal end of the actuator shaft, the handle having formed therein an aspiration hole in fluid communication with the inner lumen;

18

wherein the aspiration hole is positioned such that the aspiration hole is blocked by a portion of a monolithic actuator handle when the actuator handle is actuated, the actuator handle being pivotally coupled to the actuator shaft; and

wherein at least one of the upper and lower jaws has a proximal portion that is pivotally coupled to the elongate shaft or to the actuator shaft, and a distal portion that is removably and replaceably coupled to the proximal portion, the distal portion having a cutting blade formed thereon.

21. The tool of claim 20, wherein the distal portion comprises a removable hood having the cutting blade formed thereon for cutting tissue.

22. The tool of claim 20, wherein the distal portion comprises a removable insert having the cutting blade formed thereon for cutting tissue.

23. The tool of claim 20, wherein the proximal portion includes a mating element formed thereon for mating with a complementary mating element formed on the distal portion.

24. *The tool of claim 1, wherein the upper jaw includes a single aspiration hole formed in a middle portion thereof and wherein the lower jaw includes a first aspiration hole formed in a distal portion thereof and a second aspiration hole formed in a proximal portion thereof.*

25. *A spinal disc preparation tool, comprising:*

*an elongate shaft having an inner lumen extending there-through along a longitudinal axis between proximal and distal ends thereof;*

*a lower jaw located on a distal end of the elongate shaft for receiving tissue and delivering tissue to the inner lumen;*

*an upper jaw pivotally movable relative to the lower jaw; and*

*a handle coupled to a proximal end of the elongate shaft, the handle having formed therein an aspiration hole in fluid communication with the inner lumen;*

*wherein the aspiration hole is positioned such that the aspiration hole is blocked by a portion of a monolithic actuator handle when the actuator handle is actuated, the actuator handle being pivotally coupled to an actuator shaft coupled to the upper jaw for pivoting the upper jaw relative to the lower jaw; and*

*wherein the upper jaw includes one or more holes formed therein and the lower jaw includes one or more holes formed therein, the holes in the upper and lower jaws allowing gas to pass therethrough to aid in aspiration of cut tissue through the inner lumen.*

26. *A spinal disc preparation tool, comprising:*

*an elongate shaft having an inner lumen extending there-through along a longitudinal axis between proximal and distal ends thereof;*

*at least one aspiration hole in fluid communication with the inner lumen and formed in the elongate shaft; and*

*a tissue receiving cavity disposed at the distal end of the tool and in fluid communication with the inner lumen, an upper surface of the cavity having a pointed projection formed at a center thereof, the projection having a downward-facing surface that faces the cavity,*

*wherein a distal-facing exterior wall of the tool has concave surfaces that taper to a narrowed tip, the narrowed tip protruding downward from the downward-facing surface of the projection, the narrowed tip being configured to cut tissue.*

27. *The tool of claim 26, wherein the projection is formed at a terminal, distal-most end of the tool.*

## 19

28. The tool of claim 26, wherein the projection is adjacent to an inlet of the inner lumen.

29. The tool of claim 26, further comprising a vacuum coupled to a proximal end of the elongate shaft to aspirate tissue through the inner lumen.

30. The tool of claim 26, further comprising a tissue collector coupled to the proximal end of the elongate shaft and in fluid communication with the inner lumen.

31. The tool of claim 26, wherein the elongate shaft includes a bent portion at the distal end thereof.

32. The tool of claim 26, wherein at least a portion of the projection extends proximally towards the inner lumen.

33. A spinal disc preparation tool, comprising:

an elongate shaft having an inner lumen extending there-through along a longitudinal axis between proximal and distal ends thereof;

a lower jaw formed integrally with the elongate shaft, the lower jaw extending distally from the elongate shaft, the lower jaw having a cutting feature at an outer periphery of the lower jaw configured to cut tissue by proximal and distal translating movement of the shaft; and

a projection extending from a midpoint of the inner surface of the lower jaw, the projection being configured to cut tissue.

34. The tool of claim 33, further comprising an upper jaw pivotally coupled to the elongate shaft.

35. The tool of claim 33, wherein the projection is formed at a terminal, distal-most end of the lower jaw.

36. The tool of claim 33, wherein the projection is adjacent to an inlet of the inner lumen.

37. The tool of claim 33, further comprising a vacuum coupled to a proximal end of the elongate shaft to aspirate tissue through the inner lumen.

## 20

38. The tool of claim 33, further comprising a tissue collector coupled to the proximal end of the elongate shaft and in fluid communication with the inner lumen.

39. The tool of claim 33, wherein the distal end of the elongate shaft is arced.

40. The tool of claim 33, wherein at least a portion of the projection extends proximally towards the inner lumen.

41. A spinal disc preparation tool, comprising:

an elongate shaft having an inner lumen extending there-through along a longitudinal axis between proximal and distal ends thereof; and

a tissue receiving opening disposed at the distal end of the tool and in fluid communication with the inner lumen, wherein a distal-facing exterior wall of the tool disposed at a distal-most end of the tool has concave surfaces that taper to a narrowed tip at the center of said exterior wall, the narrowed tip being configured to cut tissue; and

wherein the narrowed tip extends inwardly from an inner surface of a projection formed on the elongate shaft, the inner surface of the projection facing the tissue-receiving opening.

42. The tool of claim 41, wherein the narrowed tip is formed in an upper jaw pivotally coupled to the elongate shaft.

43. The tool of claim 41, wherein the narrowed tip is adjacent to an inlet of the inner lumen.

44. The tool of claim 41, further comprising a vacuum coupled to the proximal end of the elongate shaft to aspirate tissue through the inner lumen.

45. The tool of claim 41, further comprising a tissue collector coupled to the proximal end of the elongate shaft and in fluid communication with the inner lumen.

46. The tool of claim 41, wherein the distal end of the elongate shaft is curved.

\* \* \* \* \*