

(19) World Intellectual Property Organization  
International Bureau



(43) International Publication Date  
6 April 2006 (06.04.2006)

PCT

(10) International Publication Number  
**WO 2006/036948 A2**

- (51) International Patent Classification:  
A63F 9/24 (2006.01)
- (21) International Application Number:  
PCT/US2005/034550
- (22) International Filing Date:  
27 September 2005 (27.09.2005)
- (25) Filing Language: English
- (26) Publication Language: English
- (30) Priority Data:  
60/613,859 28 September 2004 (28.09.2004) US
- (71) Applicant (for all designated States except US): **WMS GAMING INC.** [US/US]; 800 South Northpoint Blvd, Waukegan, IL 60085 (US).

(81) Designated States (unless otherwise indicated, for every kind of national protection available): AE, AG, AL, AM, AT, AU, AZ, BA, BB, BG, BR, BW, BY, BZ, CA, CH, CN, CO, CR, CU, CZ, DE, DK, DM, DZ, EC, EE, EG, ES, FI, GB, GD, GE, GH, GM, HR, HU, ID, IL, IN, IS, JP, KE, KG, KM, KP, KR, KZ, LC, LK, LR, LS, LT, LU, LV, LY, MA, MD, MG, MK, MN, MW, MX, MZ, NA, NG, NI, NO, NZ, OM, PG, PH, PL, PT, RO, RU, SC, SD, SE, SG, SK, SL, SM, SY, TJ, TM, TN, TR, TT, TZ, UA, UG, US, UZ, VC, VN, YU, ZA, ZM, ZW.

(84) Designated States (unless otherwise indicated, for every kind of regional protection available): ARIPO (BW, GH, GM, KE, LS, MW, MZ, NA, SD, SL, SZ, TZ, UG, ZM, ZW), Eurasian (AM, AZ, BY, KG, KZ, MD, RU, TJ, TM), European (AT, BE, BG, CH, CY, CZ, DE, DK, EE, ES, FI, FR, GB, GR, HU, IE, IS, IT, LT, LU, LV, MC, NL, PL, PT, RO, SE, SI, SK, TR), OAPI (BF, BJ, CF, CG, CI, CM, GA, GN, GQ, GW, ML, MR, NE, SN, TD, TG).

- (72) Inventors; and
- (75) Inventors/Applicants (for US only): **RASMUSSEN, James, M.** [US/US]; 5552 N. Mason Ave., Chicago, IL 60630 (US). **THOMAS, Alfred** [US/US]; 2385 E. Windmill #247, Las Vegas, NV 89123 (US).
- (74) Agents: **STEFFEY, Charles, E.** et al.; Schwegman, Lundberg, Woessner & Kluth, P.A., P.O. Box 2938, Minneapolis, MN 55402 (US).

**Published:**  
— without international search report and to be republished upon receipt of that report

For two-letter codes and other abbreviations, refer to the "Guidance Notes on Codes and Abbreviations" appearing at the beginning of each regular issue of the PCT Gazette.

(54) Title: TRANSMISSIVE LCD DISPLAY SYSTEM FOR GAMING MACHINE

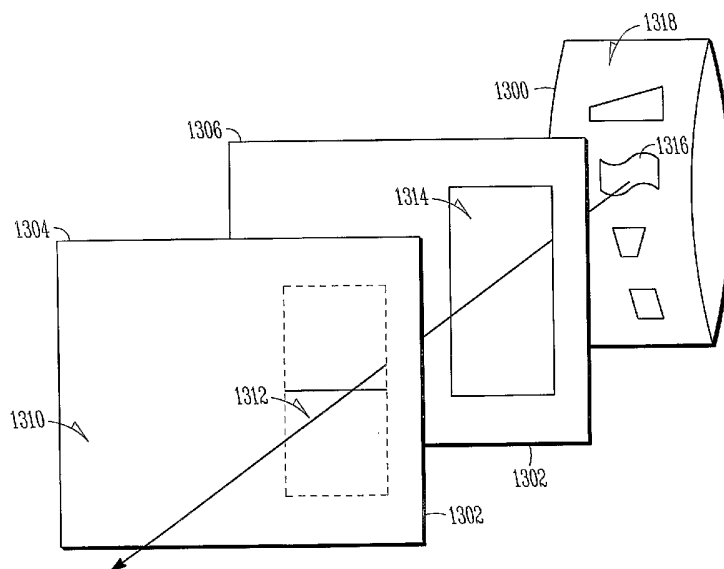

(57) Abstract: An embodiment of a gaming machine has a primary game display operable to display the outcome of a game, and a secondary display overlaying the primary game display. The secondary display may have a stand alone transmissive LCD display and at least one backlight assembly, the backlight assembly spaced apart from the transmissive LCD display and located between the transmissive LCD display and the primary game display. With the backlight assembly spaced apart from the transmissive LCD display, the backlight assembly may be removed from or inserted into the gaming machine. This permits different games to be installed in the gaming machine during manufacture or as a retrofit.

WO 2006/036948 A2

**TRANSMISSIVE LCD DISPLAY SYSTEM FOR GAMING MACHINE**

5

**Related Application(s)**

This application claims the priority benefit of U.S. Provisional Application Serial No. 60/613 859, filed 28 September 2004, the contents of which are incorporated herein by reference.

10

**Field**

The present invention relates generally to gaming machines and, more particularly, to a gaming machine with a video image superimposed over a primary display of the machine.

15

**Copyright Notice/Permission**

A portion of the disclosure of this patent document contains material that is subject to copyright protection. The copyright owner has no objection to the facsimile reproduction by anyone of the patent document or the patent disclosure as it appears in the Patent and Trademark Office patent file or records, but otherwise reserves all copyright rights whatsoever. The following notice applies to the software and data as described below and in the drawings hereto:  
Copyright © 2001-2003, WMS Gaming, Inc. All Rights Reserved.

25

**Background**

A reel spinning slot machine generally comprises a plurality of mechanical rotatable reels controlled by a processor. In response to a wager, the processor randomly selects an outcome from a plurality of possible outcomes and then causes the reels to be rotated and stopped to display the selected outcome. The selected outcome is represented by certain symbols on the reels being in visual association with a display area. If the selected outcome corresponds to a winning outcome identified on a pay table, the processor instructs a payoff mechanism to award a payoff for that winning outcome to the player in the form of coins or credits.

Heretofore, the display area of reel spinning slot machines has been fairly mundane. Any proposals for changing the appearance of the display area have been fairly minor and limited in capability. For example, in U.S. Patent No. 6,056,642 to Bennett, reel symbols are colored by backlighting the symbols with colored light bulbs or similar means. In U.S. Patent No. 6,027,115 to Griswold et al., the reels themselves contain electroluminescent elements that define one or more reel symbols, such as cherries, bars, a number "7," etc. If multiple electroluminescent elements are provided for a particular symbol, that symbol may be displayed in multiple formats. Although the above proposals change the appearance of the display area to some extent, a need exists for a structure capable of effecting more extravagant changes to the appearance of the display area.

Furthermore, in the manufacture of gaming machines it is difficult and expensive to change type of game in a game machine. It is also very difficult to retrofit a gaming machine with a new type of game.

As a result, there is a need in the art for an improved gaming machine.

### Summary

The above-mentioned shortcomings, disadvantages and problems are addressed by embodiments of the present method and apparatus, which will be understood by reading and studying the following specification.

Accordingly, an embodiment of a gaming machine has a primary game display, such as a reel, operable to display the outcome of a game, and a secondary display overlaying the primary game display. The secondary display may have a stand alone transmissive LCD display and at least one backlight assembly, the backlight assembly spaced apart from the transmissive LCD display and located between the transmissive LCD display and the primary game display. With the backlight assembly spaced apart from the transmissive LCD display, the backlight assembly may be removed from or inserted into the gaming machine. This permits different games to be installed in the gaming machine during manufacture or as a retrofit.

The present invention describes systems, clients, servers, methods, and computer-readable media of varying scope. In addition to the aspects and

advantages of the present invention described in this summary, further aspects and advantages of the invention will become apparent by reference to the drawings and by reading the detailed description that follows.

5

### **Brief Description Of The Drawings**

The foregoing and other advantages of the invention will become apparent upon reading the following detailed description and upon reference to the drawings.

10 FIG. 1a is a perspective view of a gaming machine embodying the present invention.

FIG. 1b is a side view of a game display according to embodiments of the invention.

15 FIG. 1c is an isometric view of a spinning reel slot machine embodying the present invention.

FIG. 1d is a side view of a gaming machine according to alternative embodiments of the invention.

20 FIG. 2a is a side view of a slot machine embodiment with portions broken away to reveal internal structure in accordance with embodiments of the present invention.

FIG. 2b is a side view of a slot machine embodiment with portions broken away to reveal internal structure in accordance with alternative embodiments of the present invention.

25 FIGS. 3 through 11 are front views of a display area of the slot machine with various video images superimposed on the mechanical reels.

FIG. 12 is a block diagram of a control system suitable for operating the gaming machine.

FIG. 13 depicts an embodiment of a gaming machine that has a primary game display 1300, which is a reel, operable to display the outcome of a game.

30 FIG. 14 depicts an embodiment of a gaming machine that has a primary game display 1400, such as a reel, operable to display the outcome of a game, and a secondary display 1402 overlaying the primary game display 1400.

FIGs. 15-20 depict different backlight assemblies 1500, 1600, 1700, 1800, 1900, 2000 that may have different configurations of windows (clear, that is non-lit areas) or cutouts 1502, 1602, 1702, 1802, 1902, 2002 for use with different games.

5 FIGs. 21-23 depict different embodiments of the backlight assembly.

FIG. 24 depicts a back lit reel 2400 for use in an embodiment where a light source 2402 is positioned within the reel 2400.

FIG. 25 depicts an embodiment of the primary game display 2500 that may have at least one result region 2502.

10 FIG. 26 depicts an embodiment of the primary game display 2600 in which the primary game display 2600 is a fiber optic bundle display device.

FIGs. 27 and 28 depict an embodiment in which the backlight assembly 2700 may be used with a curved LCD display 2702 with mechanical segmented barrier.

15 FIG. 29 depicts an embodiment of the primary game display 2900 in which the primary game display 2900 is a persistence of vision display device.

FIG. 30 depicts an embodiment of a method for producing a gaming machine.

20 FIG. 31 depicts an embodiment for a method for retrofitting a gaming machine.

While the invention is susceptible to various modifications and alternative forms, specific embodiments have been shown by way of example in the drawings and will be described in detail herein. It should be understood, however, that the invention is not intended to be limited to the particular forms disclosed. Rather, the invention is to cover all modifications, equivalents, and alternatives falling within the spirit and scope of the invention as defined by the  
25 appended claims.

### **Detailed Description**

30 In the following detailed description of exemplary embodiments of the invention, reference is made to the accompanying drawings which form a part hereof, and in which is shown by way of illustration specific exemplary embodiments in which the invention may be practiced. These embodiments are

described in sufficient detail to enable those skilled in the art to practice the invention, and it is to be understood that other embodiments may be utilized and that logical, mechanical, electrical and other changes may be made without departing from the scope of the present invention.

5           Some portions of the detailed descriptions that follow are presented in terms of algorithms and symbolic representations of operations on data bits within a computer memory. These algorithmic descriptions and representations are the ways used by those skilled in the data processing arts to most effectively convey the substance of their work to others skilled in the art. An algorithm is  
10 here, and generally, conceived to be a self-consistent sequence of steps leading to a desired result. The steps are those requiring physical manipulations of physical quantities. Usually, though not necessarily, these quantities take the form of electrical or magnetic signals capable of being stored, transferred,  
15 times, principally for reasons of common usage, to refer to these signals as bits, values, elements, symbols, characters, terms, numbers, or the like. It should be borne in mind, however, that all of these and similar terms are to be associated with the appropriate physical quantities and are merely convenient labels applied to these quantities. Unless specifically stated otherwise as apparent from the  
20 following discussions, terms such as “processing” or “computing” or “calculating” or “determining” or “displaying” or the like, refer to the action and processes of a computer system, or similar computing device, that manipulates and transforms data represented as physical (e.g., electronic) quantities within the computer system’s registers and memories into other data similarly  
25 represented as physical quantities within the computer system memories or registers or other such information storage, transmission or display devices.

In the Figures, the same reference number is used throughout to refer to an identical component which appears in multiple Figures. Signals and connections may be referred to by the same reference number or label, and the  
30 actual meaning will be clear from its use in the context of the description.

The following detailed description is, therefore, not to be taken in a limiting sense, and the scope of the present invention is defined only by the appended claims.

FIG. 1a illustrates an exemplary gaming machine 100 in which  
embodiments of the invention may be implemented. In some embodiments,  
gaming machine 100 is operable to conduct a wagering game. These wagering  
games may include reel based wagering games such as mechanical or video  
5 slots, card based games such as video poker, or other types of wagering games  
such as video keno, video bingo or a video dice game (e.g. a Yahtzee<sup>®</sup> like dice  
game). If based in video, the gaming machine 100 includes a video display 112  
such as a cathode ray tube (CRT), liquid crystal display (LCD), plasma, or other  
type of video display known in the art. In the illustrated embodiment, the  
10 gaming machine 100 is an "upright" version in which the display 112 is oriented  
vertically relative to a player. Alternatively, the gaming machine may be a  
"slant-top" version in which the display 112 is slanted at about a thirty-degree  
angle toward the player.

The gaming machine 100 includes a plurality of possible credit receiving  
15 mechanisms 114 for receiving credits to be used for placing wagers in the game.  
The credit receiving mechanisms 114 may, for example, include a coin acceptor,  
a bill acceptor, a ticket reader, and a card reader. The bill acceptor and the ticket  
reader may be combined into a single unit. The card reader may, for example,  
accept magnetic cards and smart (chip) cards coded with money or designating  
20 an account containing money.

In some embodiments, the gaming machine 100 includes a user interface  
comprising a plurality of push-buttons 116, and other possible devices. The  
plurality of push-buttons 116 may, for example, include one or more "bet"  
buttons for wagering, a "play" button for commencing play, a "collect" button  
25 for cashing out, a "help" button for viewing a help screen, a "pay table" button for  
viewing the pay table(s), and a "call attendant" button for calling an attendant.  
Additional game specific buttons may be provided to facilitate play of the  
specific game executed on the machine. A touch screen may define touch keys  
for implementing many of the same functions as the push-buttons. Additionally,  
30 in the case of video poker, the touch screen may implement a card identification  
function to indicate which cards a player desires to keep for the next round.  
Other possible user interface devices include a keyboard and a pointing device  
such as a mouse or trackball.

In some embodiments, gaming machine 100 includes a top box 40. Top box 40 may contain a video display, a mechanical display, or a diorama display that supplements display 112. For example, the display in top box 40 may be a wheel such as a rotating wheel, mechanical dice, a board for a board game, or  
5 other such display.

A processor controls operation of the gaming machine 100. In response to receiving a wager and a command to initiate play, the processor randomly selects a game outcome from a plurality of possible outcomes and causes the display 112 to depict indicia representative of the selected game outcome. In the  
10 case of slots for example mechanical or simulated slot reels are rotated and stopped to place symbols on the reels in visual association with one or more pay lines. If the selected outcome is one of the winning outcomes defined by a pay table, the CPU awards the player with a number of credits associated with the winning outcome.

In some embodiments, gaming machine 100 may include signage 120. Signage 120 may be a transmissive LCD device capable of displaying advertising, gaming information (e.g. type of game, denomination of game etc.) or other information to a player or potential player. Because portions of a transmissive LCD may be transparent or semi-transparent, the signage need not  
20 fully obstruct views beyond the gaming machine 100.

FIG. 1b is a side view of a game display according to embodiments of the invention and illustrates further details of the display 112. In some embodiments, display 112 includes a primary game display 120, and a secondary game display 122. In some embodiments, primary game display 120 may be a  
25 mechanical display, such as a plurality of reels for a slot machine (described further below), a wheel, including a roulette wheel, one or more dice, a pachinko board, or other board game. No embodiment of the invention is limited to any particular mechanical display. In alternative embodiments, primary game display may be a video based display such as a CRT or LCD. In further  
30 alternative embodiments, primary game display 120 may be a diorama presenting a three-dimensional model for a game environment. In some implementations the diorama may be stationary, while in other implementations the diorama may slide or move in one or more dimensions.



Secondary game display 122 is positioned over primary game display 120. In some embodiments, secondary game display 122 provides a video image that may be selectively made transparent or semi-transparent (opaque), thus allowing the display of images on secondary game display 122 while allowing selective portions of the primary game display 120 to be seen through secondary game display 122. In some embodiments, secondary display 122 is a transmissive liquid crystal display (LCD). Line of sight indicator 130 shows the viewing direction, wherein images on primary display 120 pass through transparent or semi-transparent portions of secondary game display 122 to a player.

Additionally, some embodiments of the invention include touch screen 124 mounted on secondary game display 122.

It should be noted that a secondary game display comprising a transmissive display may be positioned over top box display 40.

FIG. 1c is a side view illustrating a gaming machine 140 according to alternative embodiments of the invention. In some embodiments, a gaming machine cabinet 142 houses components of a gaming machine such as a processor and memory that control the operation of the gaming machine. A game display 144 is coupled to the processor of the gaming machine, and may be rotatably mounted to game machine cabinet 142. In some embodiments, game display 144 is placed in a substantially horizontal position when not in use, and is rotated to a non-horizontal position when a player desires to play a wagering game. Game display 144 may be a transmissive LCD device, thereby allowing a player to see through transparent or semi-transparent portions of the display.

FIG. 1d illustrates an embodiment of the invention where the primary game display comprises a spinning reel slot machine 10 that includes a plurality of mechanical rotatable reels 12a, 12b, 12c and a video display (see FIGS. 2a and 2b). In response to a wager, the reels 12a, 12b, 12c are rotated and stopped to randomly place symbols on the reels in visual association with a display area 16. Payouts are awarded based on combinations and arrangements of the symbols appearing in the display area 16. The video display provides a video image 18 occupying the display area 16 and superimposed on the reels 12a, 12b, 12c. The video image 18 may be interactive with the reels 12a, 12b, 12c, may be

static or dynamic, and may include such graphics as payout values, a pay table, pay lines, bonus game features, special effects, thematic scenery, and instructional information. In the illustrated embodiment, the slot machine 10 is an "upright" version in which the display area 16 is oriented vertically relative to the player. Alternatively, the slot machine 10 may be a "slant-top" version in which the display area 16 is slanted at about a thirty degree angle toward the player of the slot machine 10.

Referring to FIGS. 2a and 2b, the video image 18 in the display area 16 may be either a direct image (FIG. 2a) or a virtual image (FIG. 2b). If the video image 18 is a direct image, as in FIG. 2a, the direct image is preferably generated by a flat panel transmissive video display 14a positioned in front of the reels 12a, 12b, 12c. The transmissive display 14a may, for example, be a transmissive liquid crystal display (LCD) commercially available from LG Phillips LCD Co., Ltd., of Seoul, Korea. The transmissive display 14a may be outfitted with a touch screen mounted to a front surface of the display 14a. The touch screen contains soft touch keys denoted by the image on the underlying display 14a and used to operate the slot machine 10.

If the video image 18 is a virtual image, as in FIG. 2b, the virtual image is preferably generated by a projection arrangement including a video display 14b and a partially reflective mirror 20. The video display 14b and the partially reflective mirror 20 are relatively positioned to project the virtual image in front of the reels 12a, 12b, 12c between the reels and a player. The video display 14b is preferably mounted below the reels 12a, 12b, 12c and is generally perpendicular to the display area 16. The mirror 20 is preferably mounted in front of the reels 12a, 12b, 12c and is oriented at approximately a forty-five degree angle relative to both the video display 14b and the display area 16. The virtual image is generally parallel to the display area 16 and may, in fact, occupy the display area 16. Also, the virtual image may be three dimensional. In the embodiment of FIG. 2b, the display area 16 includes a glass cover/window. This cover is optionally outfitted with a touch screen that contains soft touch keys denoted by the virtual image and used to operate the slot machine 10.

The video display 14b in FIG. 2b may be a CRT, LCD, dot matrix, LED, electro-luminescent, or other type of video display known in the art. Also,

instead of mounting the video display 14b below the reels 12a, 12b, 12c, the display 14b may be mounted above the reels with the mirror 20 still oriented at approximately a forty-five degree angle relative to both the video display 14b and the display area 16.

5 Referring back to FIG. 1d, the slot machine 10 is operable to play a basic slot game with the three mechanical spinning reels 12a, 12b, 12c and a bonus game triggered by a start-bonus outcome in the basic game. The number of mechanical reels may vary, for example, to include one or more additional reels. The mechanical reels may be mounted to a horizontal axis to spin vertically as  
10 shown or may, alternatively, be mounted to a vertical axis to spin horizontally. Also, instead of each column of symbols being associated with a single reel, each individual symbol may be associated with a single reel such that a symbol array of nine symbols is associated with nine distinct reels. As shown in FIG. 12, in some embodiments of the invention, superimposed video image 18 may be  
15 used to provide one or more video reels 1102 that may be included in a wagering game along with the physical reels. The rotational motion of a video reel may be synchronized with that of physical reels 12 a-c. Additionally, in some embodiments, one or more physical reels may be removed from a wagering game by generating a superimposed video image 18 that blocks or  
20 obscures the desired reels from the view of the player.

Each of five pay lines 22a, 22b, 22c, 22d, 22e extends through one symbol on each of the three mechanical reels (and may extend through video reels 1102 in some embodiments). The number of pay lines may be more or less than five and may have various configurations. In some embodiments, one or  
25 more pay lines may be displayed on the superimposed video image 18. In addition, pay lines may be modified or skewed by the superimposed video image 18 such that the pay line passes through at least one different symbol than it did prior to the modification or skewing. A pay line may be modified or skewed at random times, predetermined times, or upon selection by a player. For example,  
30 a straight pay line may be skewed such that the pay line is no longer a straight line, but passes through symbols not in a straight line. Additional pay lines may be generated at random or at predetermined intervals during game play to

provide additional opportunities for winning combinations from those pay lines initially presented to a player.

Generally, game play is initiated by inserting a number of coins or playing a number of credits, causing a central processing unit to activate a number of pay lines corresponding to the number of coins or credits played. As shown in FIG. 3, the superimposed video image 18 may depict instructional information prompting the player to insert coins or play credits. The player selects the number of pay lines (between one and five) to play by pressing a "Select Lines" key on a button panel 24. In alternative embodiments, a player may select particular pay lines displayed on the superimposed video image using the touch screen. The player then chooses the number of coins or credits to bet on the selected pay lines by pressing a "Bet Per Line" key on the button panel 24. As shown in FIG. 4, the superimposed video image 18 may depict the activated pay lines and the number of wagered credits per pay line.

After activation of the pay lines, the reels 12a, 12b, 12c may be set in motion by touching a "Spin Reels" key on the button panel 24 or, if the player wishes to bet the maximum amount per line, by using a "Max Bet Spin" key on the button panel 24. Alternatively, other mechanisms such as, for example, a lever may be used to set the reels in motion. The central processing unit uses a random number generator to select a game outcome (e.g., "basic" game outcome) corresponding to a particular set of reel "stop positions." The central processing unit then causes each of the mechanical reels to stop at the appropriate stop position. Symbols are printed on the reels to graphically illustrate the reel stop positions and indicate whether the stop positions of the reels represent a winning game outcome.

Winning basic game outcomes (e.g., symbol combinations resulting in payment of coins or credits) are identifiable to the player by a pay table. The pay table may change over time, for example if play changes from a base wagering game to a bonus game. The superimposed video image 18 may be used to display the changed pay table.

As shown in FIG. 5, the superimposed video image 18 may depict the pay table in response to a command by the player (e.g., by pressing a "Pay Table" key on the button panel 24). A winning basic game outcome occurs when

the symbols appearing on the reels 12a, 12b, 12c along an active pay line correspond to one of the winning combinations on the pay table. A winning combination, for example, could be three matching symbols along an active pay line. If the displayed symbols stop in a winning combination, the game credits the player an amount corresponding to the award in the pay table for that combination multiplied by the amount of credits bet on the winning pay line.

As shown in FIG. 6a, the superimposed video image 18 may highlight the winning combination(s) (e.g., "7," "7," "7") and its associated pay line (e.g., pay line 22c) and depict the award for that winning combination. Alternatively, as shown in FIG. 6b, the video image 18 may obscure all symbols not appearing on an active pay line or not part of a winning outcome. The video image 18 may further include special effects such as flashing the winning pay line(s) and/or the award and providing explosions. The winning pay line(s) may flash, be accompanied by exploding flashes, and display a portion of the pay table. The player may collect the amount of accumulated credits by pressing a "Collect" key on the button panel 24. In one implementation, the winning combinations start from the first reel 12a (left to right) and span adjacent reels. In an alternative implementation, the winning combinations start from either the first reel 12a (left to right) or the third reel 12c (right to left) and span adjacent reels.

In addition, some embodiments of the invention provide supplemental game display on superimposed video image 18. For example, in some implementations, an animated or live character may interact with the game. For example, a character may be used to identify an outcome (e.g. by pointing) or the outcome may be a winning outcome because the character is pointing at it.

In some embodiments, superimposed video image 18, along with a touch screen may be used to implement side betting. For example, a player may select a symbol from the primary game display and make a side bet as to whether or not the symbol will appear during the wagering game. The side bet information may be displayed on superimposed video 18. Such a side bet is independent of the outcome of the wagering game itself. Further details on side bets used in some embodiments are disclosed in United States Patent application serial no. 10/428,516 filed May 1, 2003 and entitled "Gaming Machine with Interactive Pop-up Windows," which is hereby incorporated by reference herein.

In some embodiments, superimposed video image 18 may display a multiplier at random or predetermined intervals. The multiplier may then cause any winning outcome to be multiplied by the indicated multiplier.

5 In addition, in some embodiments, superimposed video image 18 may provide a foreground image that interacts with a background image on the primary display. For example, in some implementations, the background is a pachinko game comprising a plurality of pins and one or more lanes representing winning outcomes. The foreground image on superimposed video image 18 may comprise a simulated pachinko ball where the path through the pins is randomly  
10 generated to simulate an actual pachinko game. Similarly, the background image may comprise a roulette wheel and the foreground image on superimposed video image may be a roulette ball that “moves” around the roulette wheel and stops over a randomly selected position of the wheel. Additionally, the background may comprise a backlit board, and the foreground  
15 image may provide one or more tokens or markers that are moved to positions on the game board. In some implementations, the backlit board may comprise a ladder (i.e. a vertical strip) divided into positions having values. The foreground image may display an indicator or character (possibly animated) that points to a winning position on the ladder. Further, the background may comprise a  
20 diorama, and the foreground image may comprise one or more tokens or markers that are moved over positions in the diorama.

In some embodiments of the invention, superimposed video image 18 may be used to provide additional games instead of or in addition to interacting with a wagering game display on a primary game display 120. In one  
25 embodiment of the invention, an additional game played using superimposed video image 18 is a bank symbols game. In general, a bank symbols game operates by identifying certain symbols as “bankable” symbols. When these symbols appear on a reel or other game display, the symbol is collected in a bank symbolically displayed on superimposed video image 18. At some point during  
30 game play, if a predetermined symbol (sometimes referred to as a “break the bank” symbol) appears, the banked symbols may be redeemed for credit. Further details concerning the bank symbols game are disclosed in United States Patent 6,159,098 entitled “Dual-Award Bonus Game for a Gaming Machine,”

which is hereby incorporated by reference herein. In an alternative implementation, the banked symbols may be used to play a second game, for example tic-tac-toe.

Other additional games that may be implemented include but are not limited to horse racing and other animated games, and video bingo, keno, slots etc. that may be displayed on superimposed video image 18.

If the display area 16 includes a touch screen mounted to either the transmissive display 14a in the direct image embodiment of FIG. 2a or the glass cover in the virtual image embodiment of FIG. 2b, the video image 18 may duplicate some or all of the aforementioned keys on the button panel 24 as touch keys 26 as shown in various Figures. A player can then enable a desired function either by touching the touch screen at an appropriate touch key 26 denoted by the video image 18 or by pressing an appropriate key on the button panel 24. Touch keys 26 may also be used to implement buttons in addition to those appearing on button panel 24. For example, one or more touch keys 26 may be used to select a denomination for the wagering game, call an attendant, solicit help in playing the game, request food or drink, or request "comps."

In reel based implementations, one or more touch keys 26 may be used to implement a "skill stop" function. In these implementations, upon pressing a "skill stop" touch key, the reel or reels associated with the skill stop touch key stop rotating.

Additionally, in implementations having a diorama as a primary game display, the touch screen may be used to indicate one or more elements of the diorama that a player desires to select. The superimposed video image may be used to highlight selected elements, for example by displaying a highlighted box around the selected element.

In some embodiments of the invention, the gaming machine may be capable of providing a number of different wagering games or variations on a wagering game. In such embodiments, the superimposed video 18 may be used to provide a menu of available games and/or game variations, and a user may use the touch screen to select a desired game or game variation.

Included among the plurality of basic game outcomes is a start-bonus outcome for triggering play of a bonus game. A start-bonus outcome may be

defined in a number of ways. For example, a start-bonus outcome may occur when a special start-bonus symbol or a special combination of symbols appears on one or more of the reels 12a, 12b, 12c. The start-bonus outcome may require the combination of symbols to appear along an active pay line or may,  
5 alternatively, require that the combination of symbols appear anywhere on the display, regardless of whether the symbols are along an active pay line. The appearance of a start-bonus outcome causes the central processing unit to shift operation from the basic slot game to the bonus game.

As shown in FIG. 7, the video image 18 may depict the bonus game and  
10 any bonuses resulting therefrom. The bonus game may, for example, include free spins of a new set of video reels included in the video image 18. Winning combinations on the video reels may be defined by the same pay table as used for the mechanical reels or a different pay table altogether. The bonus game may be interactive and require a player to select one or more selectable elements 28  
15 to earn bonuses. Also, the bonus game may depict one or more animated events and award bonuses based on an outcome of the animated events. Furthermore, the bonus game may be depicted by the video image 18 alone or in conjunction with a video image depicted on an optional top box video display 40 (see FIG. 1d). The two video images may be linked to appear like one unified image. Upon  
20 completion of the bonus game, the central processing unit shifts operation back to the basic slot game.

In some embodiments, a bonus game may implement a shuffle feature. In these implementations, symbols on a reel may be converted to a number. The numbers are then displayed on superimposed video 18, and during the bonus  
25 game the numbers are shuffled. The resulting shuffled number represents the outcome of the bonus game. Further details on the shuffle feature may be found in United States Patent 6,589,114 entitled "Shuffle Feature for a Game of  
Chance" which is hereby incorporated by reference herein.

In alternative embodiments, a bonus game may be played on the primary  
30 game display, and the superimposed video image 18 may be used to highlight symbols on the primary game display to indicate that a bonus game (and not a wagering game) is being played. For instance, in a reel based wagering game, the appearance of the reels or the symbols on the reels may be changed during



bonus games. Examples of such appearance changes include changing the color, border highlighting, or shape of the reel or symbol using superimposed video 18 to indicate a bonus game is being played.

Any number of bonus games can be played, at least in part, on the  
5 superimposed video image, such as those bonus games disclosed in United States Patents 6,607,437; 6,592,457; 6,589,114; 6,561,904; 6,554,704; 6,551,187; 6,517,432; 6,506,114; 6,443,837; 6,428,412; 6,364,766; 6,358,147; 6,347,996; 6,315,660; 6,270,411; 6,234,897; 6,203,429; 6,190,255; 6,159,098; 6,159,097; 6,155,925; and 6,004,207, which are hereby incorporated by  
10 reference herein.

As shown in FIGS. 8a-c, 9a-c, and 10a-c, the video image 18 may be used to modify one or more symbols printed on one or more of the stopped mechanical reels 12a, 12b, 12c. For example, in response to a predetermined random or non-random event, the video image 18 may transform a reel symbol  
15 into a different symbol, such as a symbol needed to complete a winning combination. The different symbol is generated by the video image 18. In FIGS. 8a-c, the video image 18 depicts an animation transforming (e.g., "morphing") a blank symbol on mechanical reel 12b into a BELL symbol to form a winning combination of three BELL symbols along pay line 22c.

20 In addition, referring to FIGS. 9a-c, in response to a predetermined random or non-random event, the video image 18 may depict an animation in which a video indicator 29 is moved from a periphery of the display area (e.g., a corner of the display area away from the mechanical reels) to one or more of the symbols on the reels. The moving indicator 29 may identify the reel symbols to  
25 which it moves as a special symbol to be evaluated as, for example, a wild symbol or a scatter pay symbol. In further implementations, the moving indicator may comprise a window that moves over symbols.

In FIGS. 10a-c, a video indicator 29 has moved to a CHERRY symbol on mechanical reel 12c. If the CHERRY symbol is thereby designated a wild  
30 symbol, the displayed symbol array includes a winning combination of three MELON symbols along pay line 22c where one of the three MELON symbols is formed by the wild symbol. Further, in FIGS. 10a-c, the video image 18 depicts an animation transforming a BELL symbol on reel 12c into a SEVEN symbol to

form a winning combination of three SEVEN symbols along pay line 22c. The replacement SEVEN symbol generated by the video image 18 is sufficiently opaque or translucent to substantially cover the BELL symbol printed on mechanical reel 12c.

5           In some embodiments, the symbols display on a primary game display may be either blank or generic, and the superimposed video image 18 may be used to differentiate the symbols by adding supplemental indicia. For example, a generic reel based gaming machine may comprise reels having blank or generic symbols, and the superimposed video image may be used to provide a  
10           theme for the wagering game. Further, the symbols may be blank and the supplemental indicia may add a value to the symbol. In some embodiments, the supplemental indicia may add a rank and/or suit to symbols representing playing cards. In some embodiments, the video image 18 may be synchronized with the movement of the reels. In further implementations, a live video or generated  
15           animation may be displayed over one or more symbols on a mechanical reel.

          While symbols on reels have been described above, it should be noted that any type of symbol display mechanism may be used. For example, the symbols may appear on a “flipper” comprising a series of tabs arranged on a hub. Two of the tabs, a top and bottom tab are exposed to the player and present  
20           a symbol. As the hub rotates, the next tab “flips” over, thereby exposing a new top and bottom tab. A video image may be superimposed over such a top and bottom tab in the same manner as discussed above with respect to symbols on reels. The invention is not limited to any particular mechanism for displaying a symbol or symbol space.

25           The slot machine is preferably designed to adjust the appearance of the video image 18 in terms of transparency, translucency, or opacity depending on the purpose of the video image 18. On the one hand, to permit clear viewing of the mechanical reels 12a, 12b, 12c underlying the video image 18, the portion of the video image 18 directly overlying the reels is made more transparent.

30           On the other hand, to facilitate viewing of the video image 18 without visual interference from the underlying mechanical reels, the video image 18 is made more opaque through proper selection of colors and their level of brightness. Also, to accentuate the video image 18 relative to the underlying

reels following a reel spin, any lamps illuminating the reels during a reel spin may be turned off or dimmed following the reel spin. In addition, if the reels include blank symbols (e.g., solid white areas), any video graphics over such blank symbols will be readily visible. Similarly, any video graphics alongside, just above, or just below the underlying reels will be readily visible.

Further, in the direct image embodiment of FIG. 2a, the transmissive video display 14a may be backed by an extendable opaque shade during the bonus game. The shade is retracted from the display area 16 during the basic slot game. When the central processing unit shifts operation from the basic slot game to the bonus game, the shade extends through the display area to separate the transmissive video display 14a from the underlying reels and thereby completely shield the underlying reels.

Superimposed video image 18 may be used to display non-gaming images. For example, in some implementations, superimposed video image 18 may display advertising. Further, in attract mode, a superimposed video image 18 may be used to display images designed to entice a player to keep playing, or a potential player to start playing the wagering game.

In some embodiments of the invention, superimposed video image 18 may be used to provide an administrative interface to a gaming machine. For example, the superimposed video image 18 may provide a diagnostic interface or a setup interface for the gaming machine. In the case of a diagnostic interface, color may be used to include the status of various components within the gaming machine.

In further embodiments of the invention, superimposed video image 18 may be used to provide a live broadcast stream to a player. For example, a player may wish to view a sporting event being broadcast over public airwaves or cable channels. The superimposed video image 18 may be used to display such broadcasts while the player is playing the wagering game.

It should be noted that in nearly all cases, the images supplied by superimposed video image 18 may change over time. For example, the theme of symbols, reels or advertising may be changed based on the time of day, the day of the week, or in accordance with a holiday. Further details concerning time-based changes are disclosed in United States Patent Application Publication

2002/0039919 entitled "Gaming Machine With Video and Audio Indicia Changed Over Time," which is hereby incorporated by referenced herein.

Further, the images supplied by superimposed video image 18 may be personalized if the identity of a player is known. For example, if it is known that a player enjoys sports, the symbols, reels and other images supplied by video image 18 may be personalized with a sports theme.

FIG. 12 is a block diagram of a control system suitable for operating the gaming machine. The control system includes a central processing unit with a microcontroller 30 and system memory 32. The memory 32 preferably comprises a separate read-only memory (ROM) and battery-backed random-access memory (RAM). It will be appreciated, however, that the system memory 32 may be implemented on any of several alternative types of memory structures or may be implemented on a single memory structure. For example, the read-only memory may be replaced or supplemented with a mass storage unit such as a removable flash memory or a hard drive. The system memory may be used to store game-related data associated with the chance games played on the gaming machine. The game-related data may, for example, include game code, math tables, a random number generator, audio resources, and video resources. The player may select an amount to wager and other game play functions via the touch screen keys 26 (if provided) or button panel 24. The wager amount is signaled to the microcontroller 30 by a coin/credit detector 34. In response to the wager, the microcontroller 30 executes the game code which generates a randomly based outcome. In the case of slots, the microcontroller 30, based on the randomly generated outcome, rotates and stops the mechanical reels 12a, 12b, 12c at the selected outcome. Also, the microcontroller 30 selectively accesses the video resources to be included in the video image 18 provided by the video display 14a (FIG. 2a) or 14b (FIG. 2b) and the audio resources to be played through one or more audio speakers 36 mounted to a housing of the slot machine. If the outcome corresponds to a winning outcome identified on the pay table, the microcontroller 30 instructs a payoff mechanism 38 to award a payoff for that winning outcome to the player in the form of coins or credits.

Liquid crystal displays (LCDs) are categorized as non-emissive display devices since they do not produce any form of light. LCDs either pass or block

light that is reflected from an external light source or provided by a backlight lighting system. There are two modes of operation for LCDs during the absence of an electric field (applied power); a mode describes the transmittance state of the liquid crystal elements. Normal white mode means the display is white or clear and allows light to pass through. Normal black mode means the display is dark and all light is diffused.

Typically, in a dot matrix LCD a twisted nematic (TN) LCD has two polarizers, two pieces of glass, some form of switching element or electrode to define pixels, and driver integrated circuits (ICs) to address the rows and columns of pixels. To define a pixel (or subpixel element for a color display), a rectangle is constructed out of Indium Tin Oxide (ITO), which is a semi-transparent metal oxide, and charge is applied to this area in order to change the orientation of the liquid crystal material (change from a white pixel to a dark pixel).

Polarizers are an integral part of a LCD, possessing the unique property of only passing light if it is oriented in a specific (oriented) direction. To utilize this phenomenon in TN LCD, the bottom polarizer orients incoming light in one direction. The oriented light passes through the liquid crystal display material and is either unaltered or "bent" 90 degrees. Depending on the orientation of the top polarizer, this light will either pass through or be diffused. If the light is diffused, it will appear as a dark area.

Polarizers are also one of the major reasons that LC displays require bright back lighting. The polarizers and liquid crystal materials absorb more than 50% of the incident light.

After final assembly in known LCDs, excess glass is cut and driver ICs are mounted. The finished display is mounted onto a backlight assembly and encased in metal. There are a number of methods for backlighting a LCD. Some displays usually have a side, top, or bottom lighting system. In a side-lit display one or two fluorescent tubes are located at the left and or right edges of the display. A fluorescent tube, normally 4 mm in diameter, is used.

Also in known LCDs a plastic plate around the entire area of the display disperses light from the fluorescent tubes. A dispersion plate may look like a white sheet with small holes, each of the holes providing a small point of light.

On top of the dispersion plate, a diffuser may be placed. A diffuser takes the numerous points of light and uniformly spreads it out over the entire area of the display. The net effect is providing a backlighting source around 4 or 5 mm thick.

5 An organic light emitting diode (OLED) is an electronic device made by placing a series of organic thin films between two conductors. When electrical current is applied, a bright light is emitted. This process is called electrophosphorescence. Even with a layered system, these systems are very thin, usually less than 500 nm (0.5 thousandths of a millimeter).

10 When used to produce displays, OLED technology produces self-luminous displays that do not require backlighting. These properties result in thin, very compact displays. The displays also have a wide viewing angle, up to 160 degrees and require very little power, only 2-10 volts.

FIG. 13 depicts an embodiment of a gaming machine that has a primary  
15 game display 1300, which is a reel, operable to display the outcome of a game. A secondary display 1302 overlays the primary game display 1300 and may have a stand alone transmissive LCD display 1304 and at least one backlight assembly 1306, the backlight assembly 1306 spaced apart from the transmissive LCD display 1304 and located between the transmissive LCD display 1304 and  
20 the primary game display 1300. In an embodiment the stand alone transmissive LCD display 1304 may have at least one non-transmissive display area 1310, and at least one transmissive display area 1312.

A window or cutout 1314 in the backlight assembly 1306 is in alignment with the transmissive area 1312 in the transmissive LCD display 1304 so that an  
25 image may be formed on the transmissive area 1312 over the item 1316 on the reel 1300. The primary game display 1300 may also have a white area 1318, for example, that when aligned with the window or cutout 1314 allows only the image in the transmissive area 1312 to be viewed.

As described above the primary game display may be operable to display  
30 a sequence of symbols in a symbol array having at least one row and a plurality of columns, the sequence defining a first award. The bonus game may encompass a reordering of the sequence of symbols in the symbol array. The primary game display may be operable to display a sequence of symbols in a

symbol array having at least one row and a plurality of columns, the sequence defining a first award. In this embodiment the secondary game display may be operable to change the appearance of at least one symbol in the primary game display. Also, as described above, the stand-alone transmissive LCD display  
5 may also have a touch screen.

In an embodiment the secondary game display may be operable to highlight an area around at least one of the plurality of columns. In another embodiment the secondary game display may be operable to change the appearance, such as a color, of at least one symbol in the primary game display.

10 In a further embodiment the primary game display may be operable to display a sequence of symbols in a symbol array having at least one column and a plurality of rows, the sequence defining a first award. The secondary game may be operable to copy at least one symbol from the primary game display to a saved collection of symbols displayed on the secondary game display.

15 The secondary game may be a wagering game played in response to a second wager. For example, the secondary game may be one of a sports based game, a horse racing, an animated game, and a game selected from a group consisting of keno, bingo, video slots, and roulette.

FIG. 14 depicts an embodiment of a gaming machine that has a primary  
20 game display 1400, such as a reel, operable to display the outcome of a game, and a secondary display 1402 overlaying the primary game display 1400. The secondary display 1402 may have a stand alone transmissive LCD display 1404 and at least one backlight assembly 1406, the backlight assembly 1406 spaced apart from the transmissive LCD display 1404 and located between the  
25 transmissive LCD display 1404 and the primary game display 1400. With the backlight assembly 1406 spaced apart from the transmissive LCD display 1404, the backlight assembly 1406 may be removed from or inserted into the gaming machine (as indicated by arrow 1408). This permits different games to be  
30 installed in the gaming machine during manufacture or as a retrofit as described below.

In further embodiments of the gaming machine, the primary display 1400 may be at least one of a plurality of reels, a plurality of scrolling devices, a curved LCD display with mechanical segmented barrier, a fiber optic reel

simulation, and volumetric displays (such as, persistence of vision devices). The secondary display 1402 may be a secondary game display operable to display the results of a secondary game, such as a bonus game.

For example, the transmissive LCD display 1404 may be programmed to display a variety of different images or effects for different games. Selected areas of the transmissive portion of the transmissive LCD display 1404 may be used for different games by using different backlight assemblies 1406.

FIGs. 15-20 depict different backlight assemblies 1500, 1600, 1700, 1800, 1900, 2000 that may have different configurations of windows (clear, that is non-lit areas) or cutouts 1502, 1602, 1702, 1802, 1902, 2002 for use with different games. For example, the backlight assemblies 1500, 1600, 1700, 1800 may be used with rotating reels. The backlight assembly 1900 may be used with a curved LCD display with mechanical segmented barrier. The backlight assembly 2000 may used with a pair of dice images. Other configurations are possible.

FIGs. 21-23 depict different embodiments of the backlight assembly. The backlight assembly 2100, 2200, 2300 may be one of an edge lit panel 2102, a surface LED (light emitting diode) panel 2202, and a surface OLED (organic light emitting diode) panel 2302. The edge lit panel 2102 in FIG. 21 may be illuminated in this embodiment by two fluorescent light sources 2104, 2106. A diffuser 2108 provides even lighting over the edge lit panel 2102. The diffuser 2108 does not cover window areas 2110.

In FIG. 22 a plurality of LEDs 2202 are distributed over the panel 2200. The number of LEDs 2202 are such that substantially even lighting is created. Similarly, in FIG. 23 a plurality of OLEDs 2302 are distributed over the panel 2300.

An organic light emitting diode is an electronic device made by placing a series of organic thin films between two conductors. When electrical current is applied, a bright light is emitted. This process is called electrophosphorescence. Even with a layered system, these systems are very thin, usually less than 500 nm (0.5 thousandths of a millimeter).

When used to produce displays, OLED technology produces self-luminous displays that do not require backlighting. These properties result in



thin, very compact displays. The displays also have a wide viewing angle, up to 160 degrees and require very little power, only 2-10 volts.

As described above, in some embodiments each reel of a plurality of reels may have a substantially white area. Similarly, each scrolling device of the plurality of scrolling devices may have a substantially white area. These white areas may be lit from the front or rear, and when lit provide a backlight for the transmissive display area of the transmissive LCD display.

FIG. 24 depicts a back lit reel 2400 for use in an embodiment where a light source 2402 is positioned within the reel 2400. The backlight assembly 2404 may then have at least one cutout 2406 in visual association with a transmissive area 2408 of the transmissive LCD display 2410.

FIG. 25 depicts an embodiment of the primary game display 2500 that may have at least one result region 2502. The backlight assembly 2504 may then have at least one cutout 2506 in visual association with the result region 2502 of the primary game display 2500. The cutout 2506 may then have a perimeter with light cups 2508 that illuminate the result region 2502 of the primary game display 2500. The transmissive LCD display 2510 displays an image in transmissive area 2512.

FIG. 26 depicts an embodiment of the primary game display 2600 in which the primary game display 2600 is a fiber optic bundle display device 2602, such as disclosed in U.S. Patent Application Publication 2003/0157980.

FIGs. 27 and 28 depict an embodiment in which the backlight assembly 2700 may be used with a curved LCD display 2702 with mechanical segmented barrier 2704. Segmented light source 2706 may supply backlight for the curved LCD display 2702.

FIG. 29 depicts an embodiment of the primary game display 2900 in which the primary game display 2900 is a persistence of vision display device 2902, such as disclosed in U.S. Patent Application Publication 2003/0176214.

Thus in general, some embodiments of the primary game display may have at least one result region, and the backlight assembly may have at least one light source, and a diffuser. The backlight assembly may then have at least one non-diffused area in visual association with the result region of the primary game display. The primary game display may have a source of illumination for

the result region. In another embodiment the gaming machine may have a primary game display operable to display the outcome of a wagering game in response to a wager. A secondary display may overlay the primary game display. This secondary display may have a stand alone transmissive LCD display and a plurality of interchangeable backlight assemblies. An installed backlight assembly of the plurality of backlight assemblies may be spaced apart from the transmissive LCD display and may be located between the transmissive LCD display and the primary game display. Each backlight assembly of the plurality of backlight assemblies may be associated respectively with at least one of a predetermined display of a plurality of displays and a predetermined game of a plurality of games.

FIG. 30 depicts an embodiment of a method for producing a gaming machine. In this embodiment the method may include: providing a primary game display that displays an outcome of a wagering game (3001); overlapping the primary game display with a stand alone transmissive LCD display (3002); providing a plurality of interchangeable backlight assemblies, each backlight assembly of the plurality of interchangeable backlight assemblies associated respectively with at least one of a predetermined display of a plurality of displays and a predetermined game of a plurality of games (3003); selecting a backlight assembly from the plurality of backlight assemblies (3004); and installing the selected backlight assembly of the plurality of backlight assemblies between the transmissive LCD display and the primary game display and spacing the selected backlight assembly of the plurality of backlight assemblies apart from the transmissive LCD display (3005).

FIG. 31 depicts an embodiment for a method for retrofitting a gaming machine. In this embodiment the method may include: providing a primary game display that displays an outcome of a wagering game (3101); overlapping the primary game display with a stand alone transmissive LCD display (3102); providing a plurality of interchangeable backlight assemblies, each backlight assembly of the plurality of interchangeable backlight assemblies associated respectively with at least one of a predetermined display of a plurality of displays and a predetermined game of a plurality of games (3103); selecting a backlight assembly from the plurality of backlight assemblies (3104); removing

an existing backlight assembly from between the transmissive LCD display and the primary game display (3105); and installing the selected backlight assembly of the plurality of backlight assemblies between the transmissive LCD display and the primary game display and spacing the selected backlight assembly of the  
5 plurality of backlight assemblies apart from the transmissive LCD display (3106).

While the present invention has been described with reference to one or more particular embodiments, those skilled in the art will recognize that many changes may be made thereto without departing from the spirit and scope of the  
10 present invention.

#### Conclusion

Various embodiments of a gaming machine with a superimposed video image have been disclosed. Although specific embodiments have been  
15 illustrated and described herein, it will be appreciated by those of ordinary skill in the art that any arrangement, which is calculated to achieve the same purpose, may be substituted for the specific embodiments shown. This application is intended to cover any adaptations or variations of the present invention.

The terminology used in this application is meant to include all of these  
20 environments. It is to be understood that the above description is intended to be illustrative, and not restrictive. Many other embodiments will be apparent to those of skill in the art upon reviewing the above description. Therefore, it is manifestly intended that this invention be limited only by the following claims and equivalents thereof.

We claim:

1. A gaming machine comprising:
  - a primary game display operable to display the outcome of a game;
  - a secondary display overlaying the primary game display; and
  - the secondary display having a stand alone transmissive LCD display and at least one backlight assembly, the backlight assembly spaced apart from the transmissive LCD display and located between the transmissive LCD display and the primary game display.
2. The gaming machine of claim 1, wherein the primary game display has a mechanical portion.
3. The gaming machine claim 1, wherein the secondary display is a secondary game display operable to display the results of a secondary game.
4. The gaming machine of claim 3, wherein the secondary game comprises a bonus game.
5. The gaming machine of claim 4, wherein the primary game display is operable to display a sequence of symbols in a symbol array having at least one column and a plurality of rows, the sequence defining a first award, and further wherein the bonus game comprises a reordering of the sequence of symbols in the symbol array.
6. The gaming machine of claim 4, wherein the primary game display is operable to display a sequence of symbols in a symbol array having at least one column and a plurality of rows, the sequence defining a first award, and further wherein the secondary game display is operable to change the appearance of at least one symbol in the primary game display.
7. The gaming machine of claim 6, wherein the secondary game display is operable to highlight an area around at least one of the plurality of rows.

8. The gaming machine of claim 6, wherein the secondary game display is operable to change the color of at least one symbol in the primary game display.
9. The gaming machine of claim 3, wherein the primary game display is operable to display a sequence of symbols in a symbol array having at least one column and a plurality of rows, the sequence defining a first award, and further wherein the secondary game is operable to copy at least one symbol from the primary game display to a saved collection of symbols displayed on the secondary game display.
10. The gaming machine of claim 3, wherein the secondary game comprises a wagering game played in response to a second wager.
11. The gaming machine of claim 10, wherein the secondary game comprises one of a sports based game, a horse racing, an animated game, and a game selected from a group consisting of keno, bingo, video slots, and roulette.
12. The gaming machine of claim 1, wherein the stand alone transmissive LCD display has a touch screen.
13. The gaming machine of claim 1, wherein the stand alone transmissive LCD display has at least one non-transmissive display area, and at least one transmissive display area.
14. The gaming machine of claim 1, wherein the at least one backlight assembly is interchangeable with another backlight assembly.
15. The gaming machine of claim 1, wherein the primary display is at least one of a plurality of reels, a plurality of scrolling devices, a curved LCD display with segmented barrier, a fiber optic reel simulation, a paltronic display, and volumetric display.

16. The gaming machine of claim 15, wherein each reel of the plurality of reels has a substantially white area.
17. The gaming machine of claim 15, wherein each scrolling device of the plurality of scrolling devices has a substantially white area.
18. The gaming machine of claim 1, wherein the backlight assembly is one of an edge lit panel, a surface LED panel, a surface OLED (organic light emitting diode) panel.
19. The gaming machine of claim 1, wherein the backlight assembly has at least one light source, a dispersion plate, and a diffuser.
20. The gaming machine of claim 1, wherein the backlight assembly has at least one light source, and a diffuser.
21. The gaming machine of claim 1, wherein the primary game display has at least one result region, and wherein the backlight assembly has at least one cutout in visual association with the result region of the primary game display.
22. The gaming machine of claim 1, wherein the primary game display has at least one result region, and wherein the backlight assembly has at least one cutout in visual association with the result region of the primary game display, and wherein the cutout has a perimeter with light cups that illuminate the result region of the primary game display.
23. The gaming machine of claim 1, wherein the primary game display has at least one result region, wherein the backlight assembly has at least one light source, and a diffuser, and wherein the backlight assembly has at least one non-diffused area in visual association with the result region of the primary game display.

24. The gaming machine of claim 1, wherein the primary game display has at least one result region, wherein the backlight assembly has at least one light source, and a diffuser, wherein the backlight assembly has at least one of a non-diffused area and a cutout in visual association with the result region of the primary game display, and wherein the primary game display has a source of illumination for the result region.

25. A gaming machine comprising:  
a primary game display operable to display the outcome of a wagering game in response to a wager;  
a secondary display overlaying the primary game display;  
the secondary display having a stand alone transmissive LCD display and a plurality of interchangeable backlight assemblies, an installed backlight assembly of the plurality of backlight assemblies spaced apart from the transmissive LCD display and located between the transmissive LCD display and the primary game display; and  
each backlight assembly of the plurality of backlight assemblies associated respectively with at least one of a predetermined display of a plurality of displays and a predetermined game of a plurality of games.

26. The gaming machine of claim 25, wherein the primary game display has a mechanical portion.

27. The gaming machine claim 25, wherein the secondary display is a secondary game display operable to display the results of a secondary game.

28. The gaming machine of claim 27, wherein the secondary game comprises a bonus game.

29. The gaming machine of claim 28, wherein the primary game display is operable to display a sequence of symbols in a symbol array having at least one column and a plurality of rows, the sequence defining a first award, and further wherein the bonus game comprises a reordering of the sequence of symbols in the symbol array.

30. The gaming machine of claim 28, wherein the primary game display is operable to display a sequence of symbols in a symbol array having at least one column and a plurality of rows, the sequence defining a first award, and further wherein the secondary game display is operable to change the appearance of at least one symbol in the primary game display.

31. The gaming machine of claim 30, wherein the secondary game display is operable to highlight an area around at least one of the plurality of rows.

32. The gaming machine of claim 30, wherein the secondary game display is operable to change the color of at least one symbol in the primary game display.

33. The gaming machine of claim 28, wherein the primary game display is operable to display a sequence of symbols in a symbol array having at least one column and a plurality of rows, the sequence defining a first award, and further wherein the secondary game is operable to copy at least one symbol from the primary game display to a saved collection of symbols displayed on the secondary game display.

34. The gaming machine of claim 28, wherein the secondary game comprises a wagering game played in response to a second wager.

35. The gaming machine of claim 34, wherein the secondary game comprises one of a sports based game, a horse racing, an animated game, and a game selected from a group consisting of keno, bingo, video slots, and roulette.



36. The gaming machine of claim 25, wherein the stand alone transmissive LCD display has a touch screen.
37. The gaming machine of claim 25, wherein the stand alone transmissive LCD display has at least one non-transmissive display area, and at least one transmissive display area.
38. The gaming machine of claim 25, wherein the primary display is at least one of a plurality of reels, a plurality of scrolling devices, a curved LCD display with segmented barrier, a fiber optic reel simulation, and volumetric display.
39. The gaming machine of claim 38, wherein each reel of the plurality of reels has a substantially white area.
40. The gaming machine of claim 38, wherein each scrolling device of the plurality of scrolling devices has a substantially white area.
41. The gaming machine of claim 25, wherein the backlight assembly is one of an edge lit panel, a surface LED panel, a surface OLED (organic light emitting diode) panel.
42. The gaming machine of claim 25, wherein the backlight assembly has at least one light source, a dispersion plate, and a diffuser.
43. The gaming machine of claim 25, wherein the backlight assembly has at least one light source, and a diffuser.
44. The gaming machine of claim 25, wherein the primary game display has at least one result region, and wherein the backlight assembly has at least one cutout in visual association with the result region of the primary game display.

45. The gaming machine of claim 25, wherein the primary game display has at least one result region, and wherein the backlight assembly has at least one cutout in visual association with the result region of the primary game display, and wherein the cutout has a perimeter with light cups that illuminate the result region of the primary game display.

46. The gaming machine of claim 25, wherein the primary game display has at least one result region, wherein the backlight assembly has at least one light source, and a diffuser, and wherein the backlight assembly has at least one non-diffused area in visual association with the result region of the primary game display.

47. The gaming machine of claim 25, wherein the primary game display has at least one result region, wherein the backlight assembly has at least one light source, and a diffuser, wherein the backlight assembly has at least one of a non-diffused area and a cutout in visual association with the result region of the primary game display, and wherein the primary game display has a source of illumination for the result region.

48. A method for producing a gaming machine, comprising the steps of:  
providing a primary game display that displays an outcome of a wagering game;  
overlapping the primary game display with a stand alone transmissive LCD display;  
providing a plurality of interchangeable backlight assemblies, each backlight assembly of the plurality of interchangeable backlight assemblies associated respectively with at least one of a predetermined display of a plurality of displays and a predetermined game of a plurality of games;  
selecting a backlight assembly from the plurality of backlight assemblies;  
and

installing the selected backlight assembly of the plurality of backlight assemblies between the transmissive LCD display and the primary game display and spacing the selected backlight assembly of the plurality of backlight assemblies apart from the transmissive LCD display.

49. The gaming machine of claim 48, wherein the primary game display has a mechanical portion.
50. The gaming machine of claim 48, wherein the primary game display has at least one result region, wherein the backlight assembly has at least one light source, and a diffuser, and wherein the backlight assembly has at least one non-diffused area in visual association with the result region of the primary game display.
51. The gaming machine of claim 48, wherein the primary game display has at least one result region, wherein the backlight assembly has at least one light source, and a diffuser, wherein the backlight assembly has at least one of a non-diffused area and a cutout in visual association with the result region of the primary game display, and wherein the primary game display has a source of illumination for the result region.
52. A method for retrofitting a gaming machine, comprising the steps of:  
providing a primary game display that displays an outcome of a wagering game;  
overlapping the primary game display with a stand alone transmissive LCD display;  
providing a plurality of interchangeable backlight assemblies, each backlight assembly of the plurality of interchangeable backlight assemblies associated respectively with at least one of a predetermined display of a plurality of displays and a predetermined game of a plurality of games;  
selecting a backlight assembly from the plurality of backlight assemblies;  
removing an existing backlight assembly from between the transmissive LCD display and the primary game display; and

installing the selected backlight assembly of the plurality of backlight assemblies between the transmissive LCD display and the primary game display and spacing the selected backlight assembly of the plurality of backlight assemblies apart from the transmissive LCD display.

53. The gaming machine of claim 52, wherein the primary game display has a mechanical portion.

54. The gaming machine of claim 52, wherein the primary game display has at least one result region, wherein the backlight assembly has at least one light source, and a diffuser, and wherein the backlight assembly has at least one non-diffused area in visual association with the result region of the primary game display.

55. The gaming machine of claim 52, wherein the primary game display has at least one result region, wherein the backlight assembly has at least one light source, and a diffuser, wherein the backlight assembly has at least one of a non-diffused area and a cutout in visual association with the result region of the primary game display, and wherein the primary game display has a source of illumination for the result region.

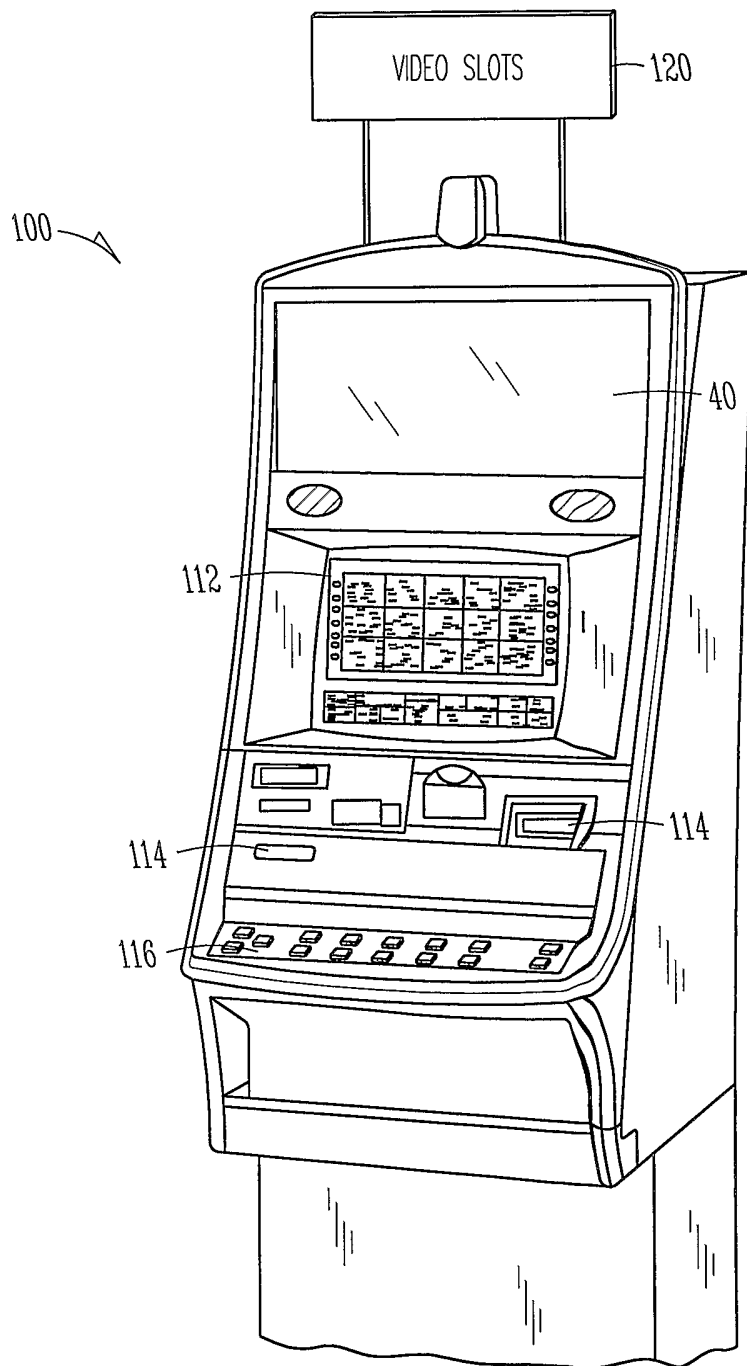

FIG. 1A

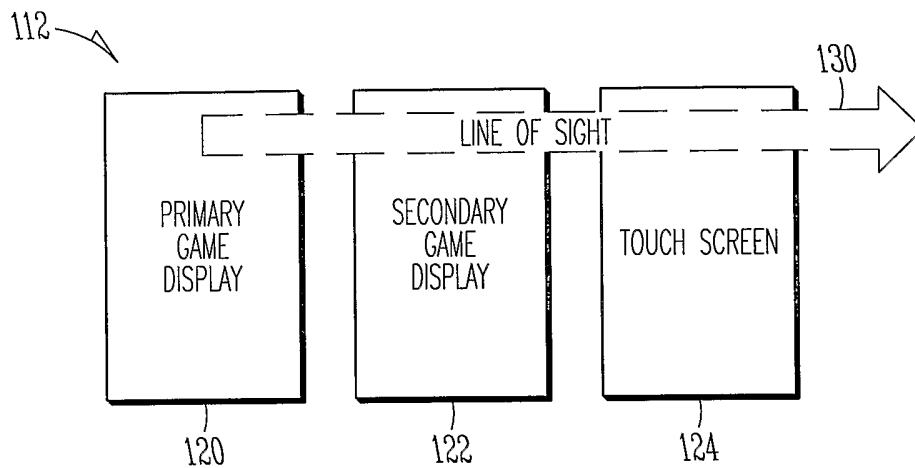

FIG. 1B

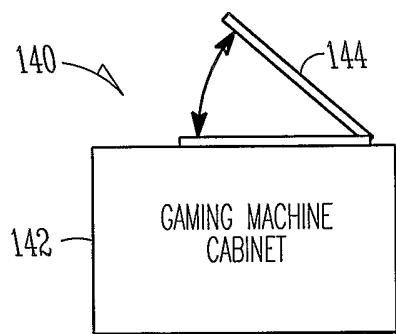
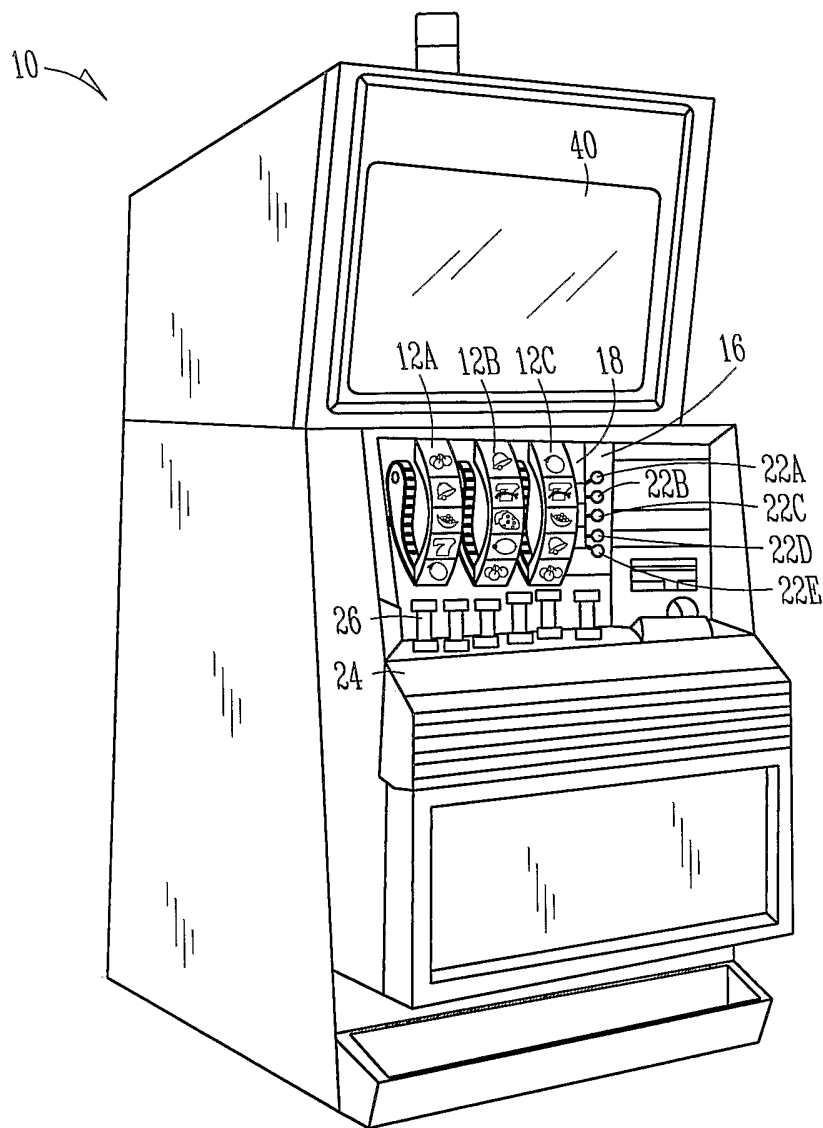
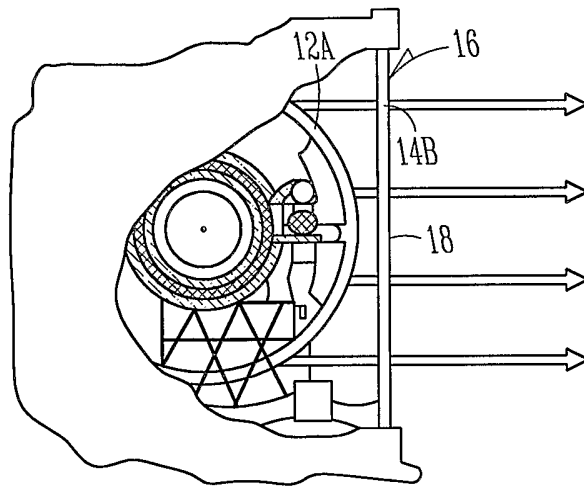

FIG. 1C

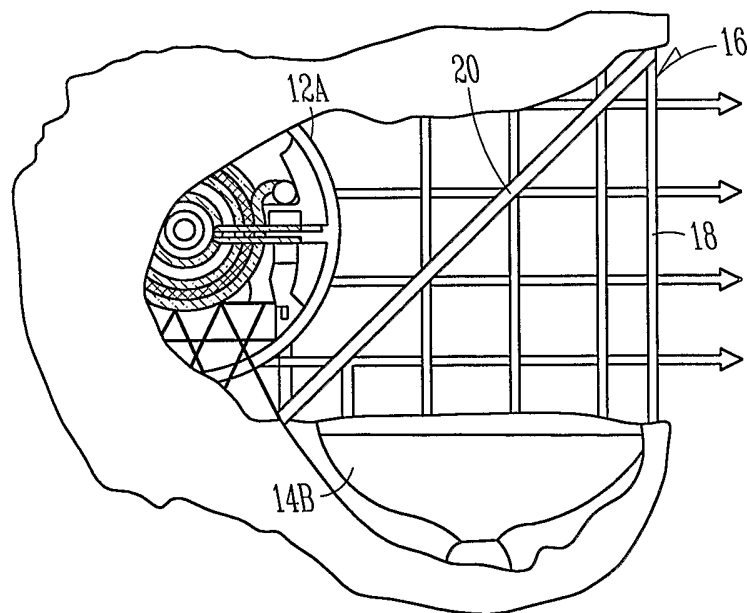

*FIG. 1D*

4/28



*FIG. 2A*



*FIG. 2B*



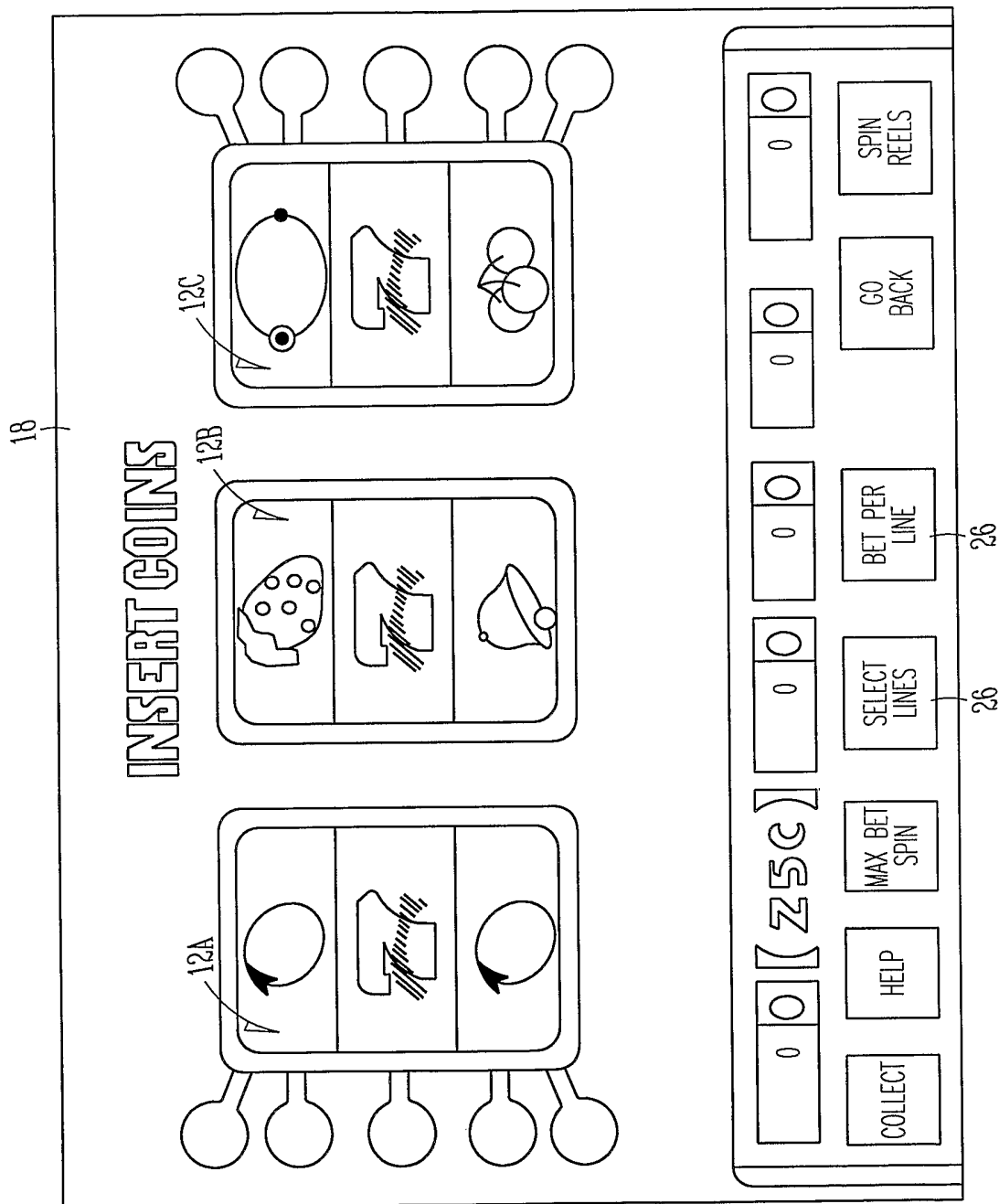

FIG. 3

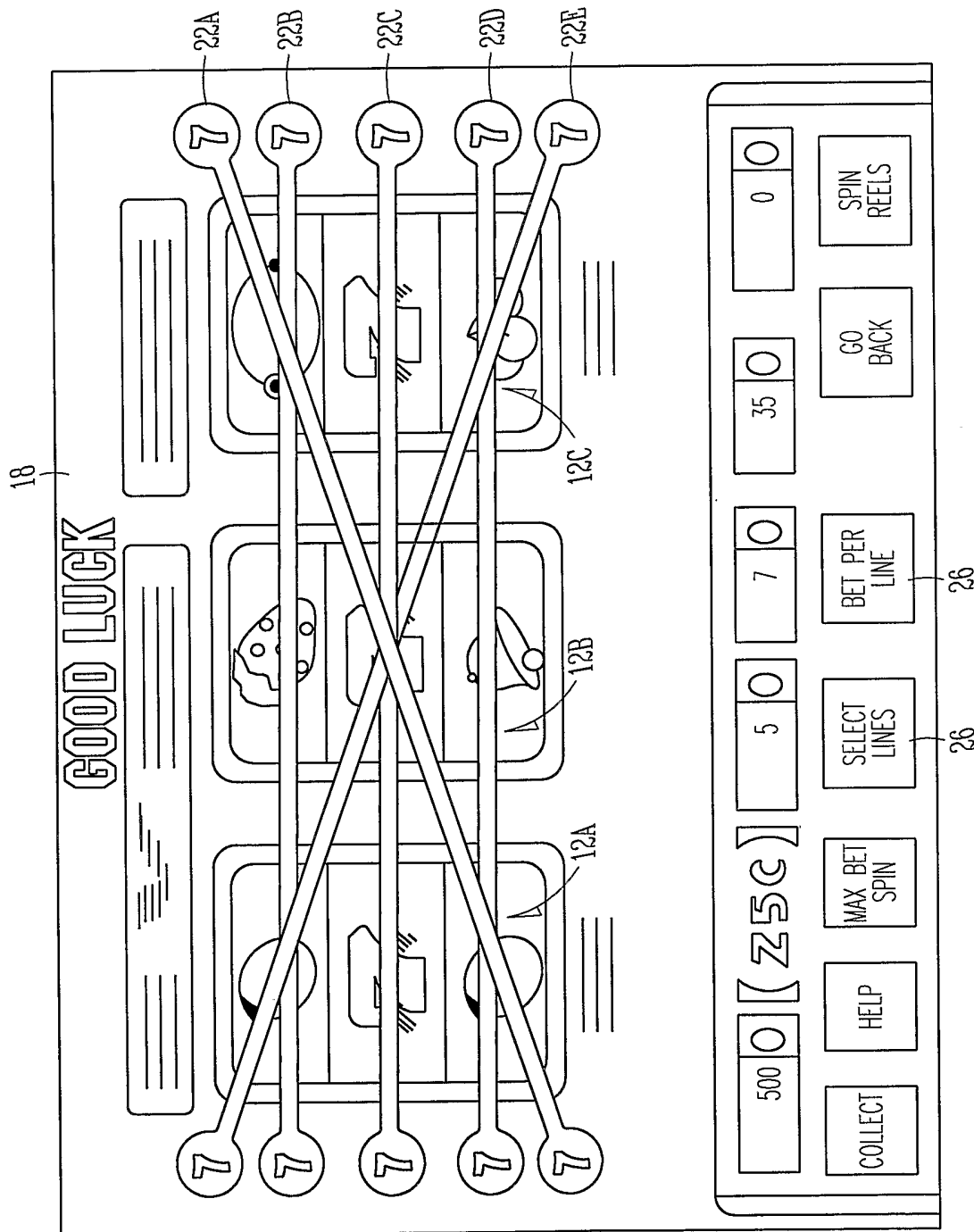

FIG. 4

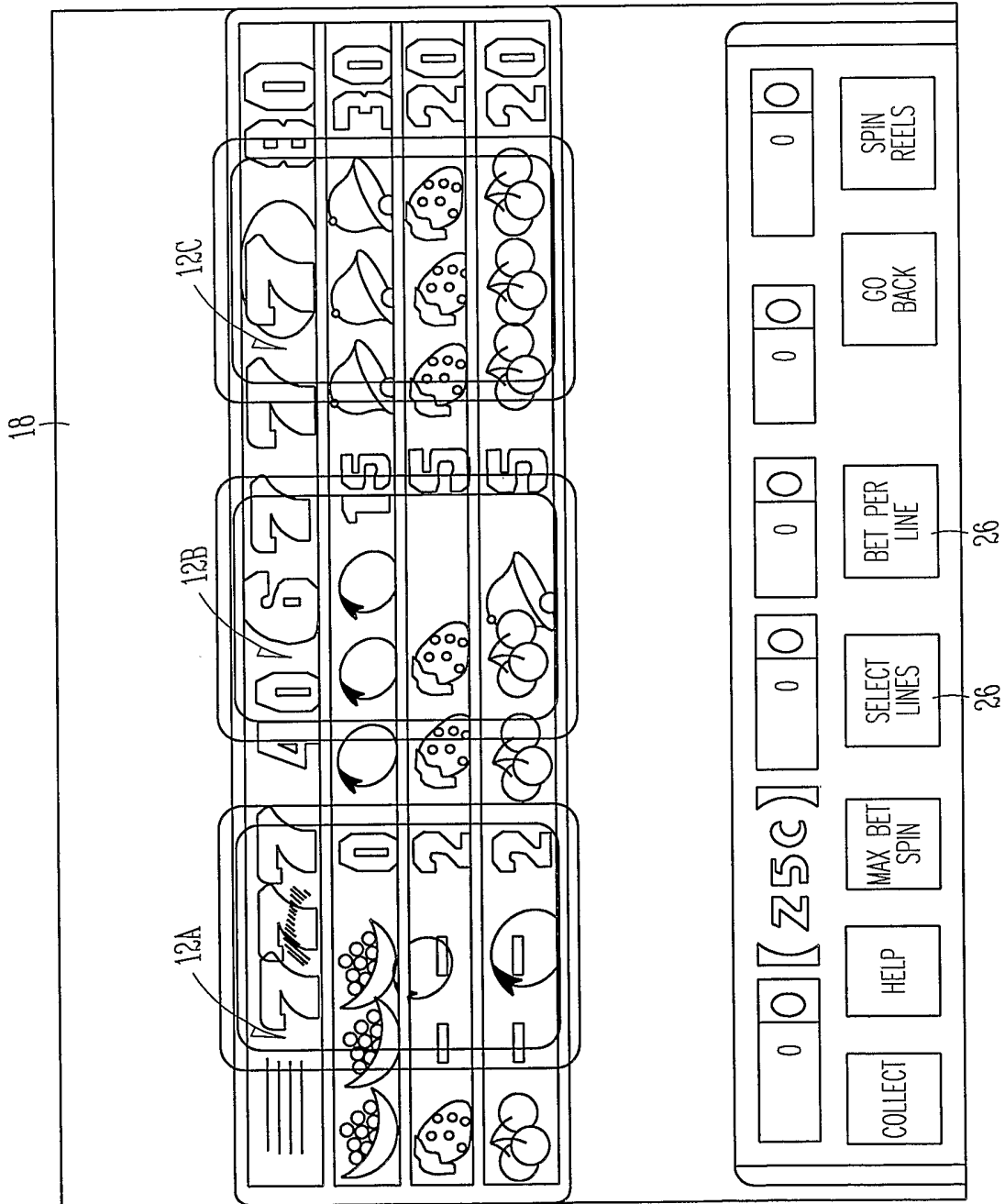

FIG. 5

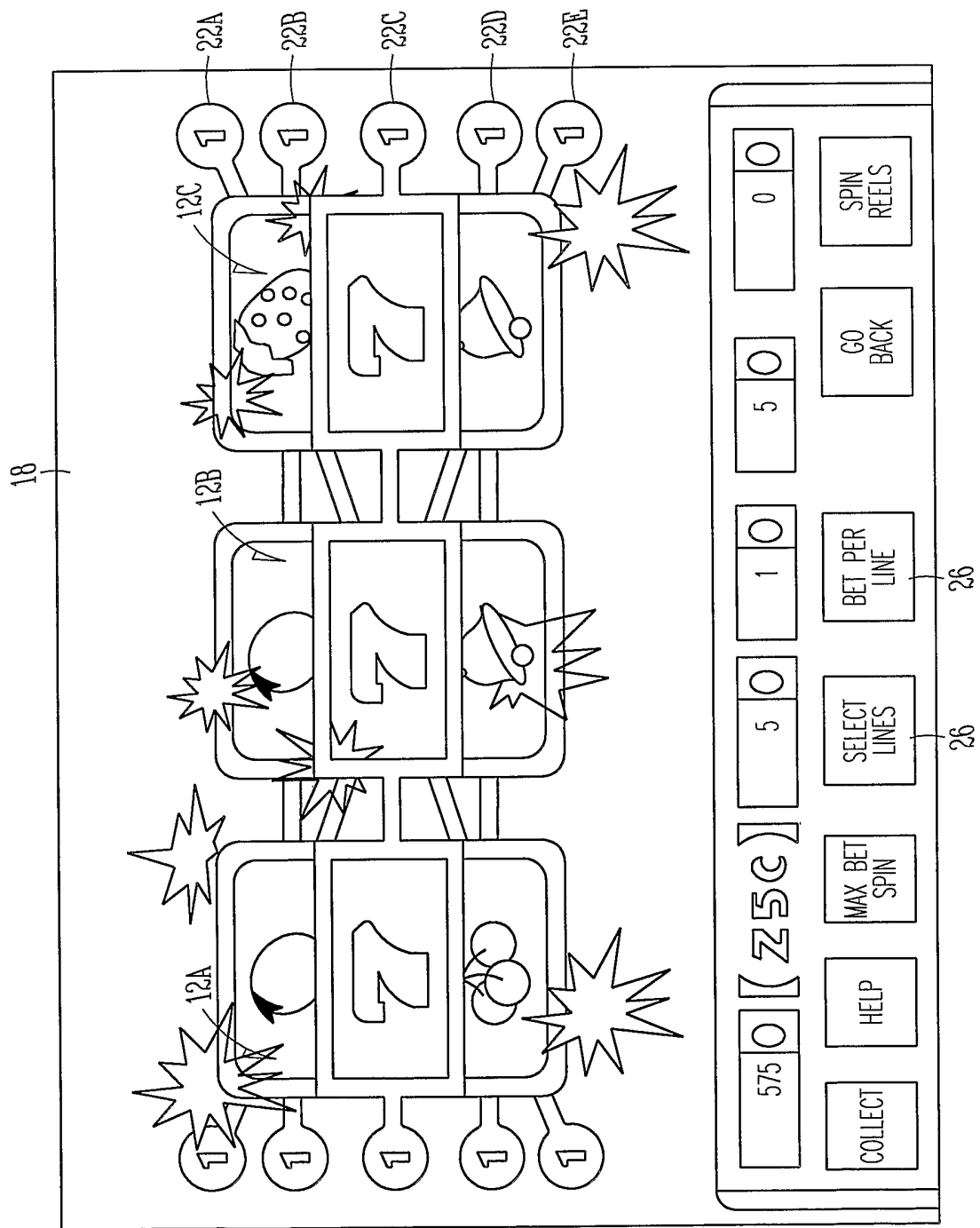

FIG. 6A

9/28

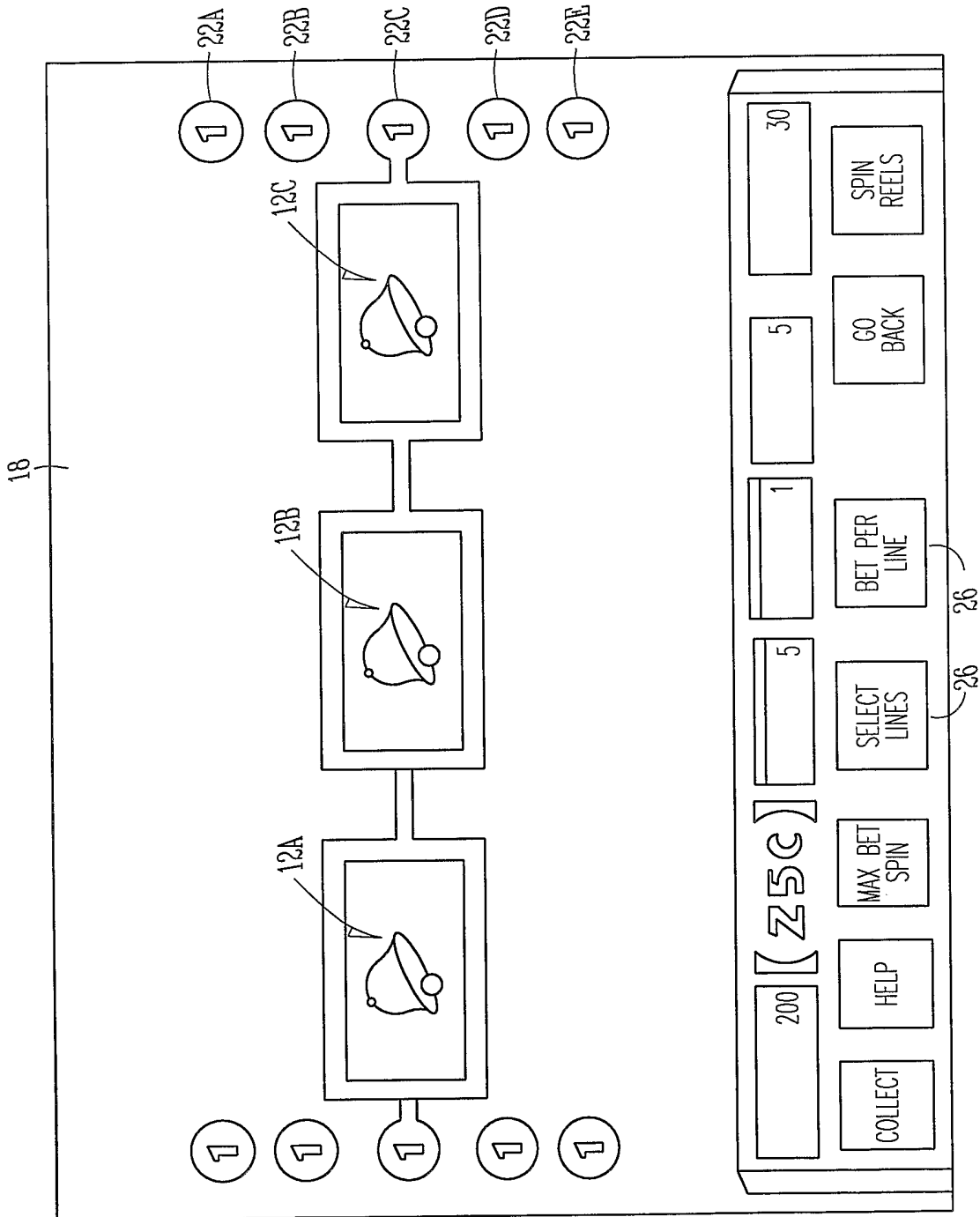

FIG. 6B

10/28

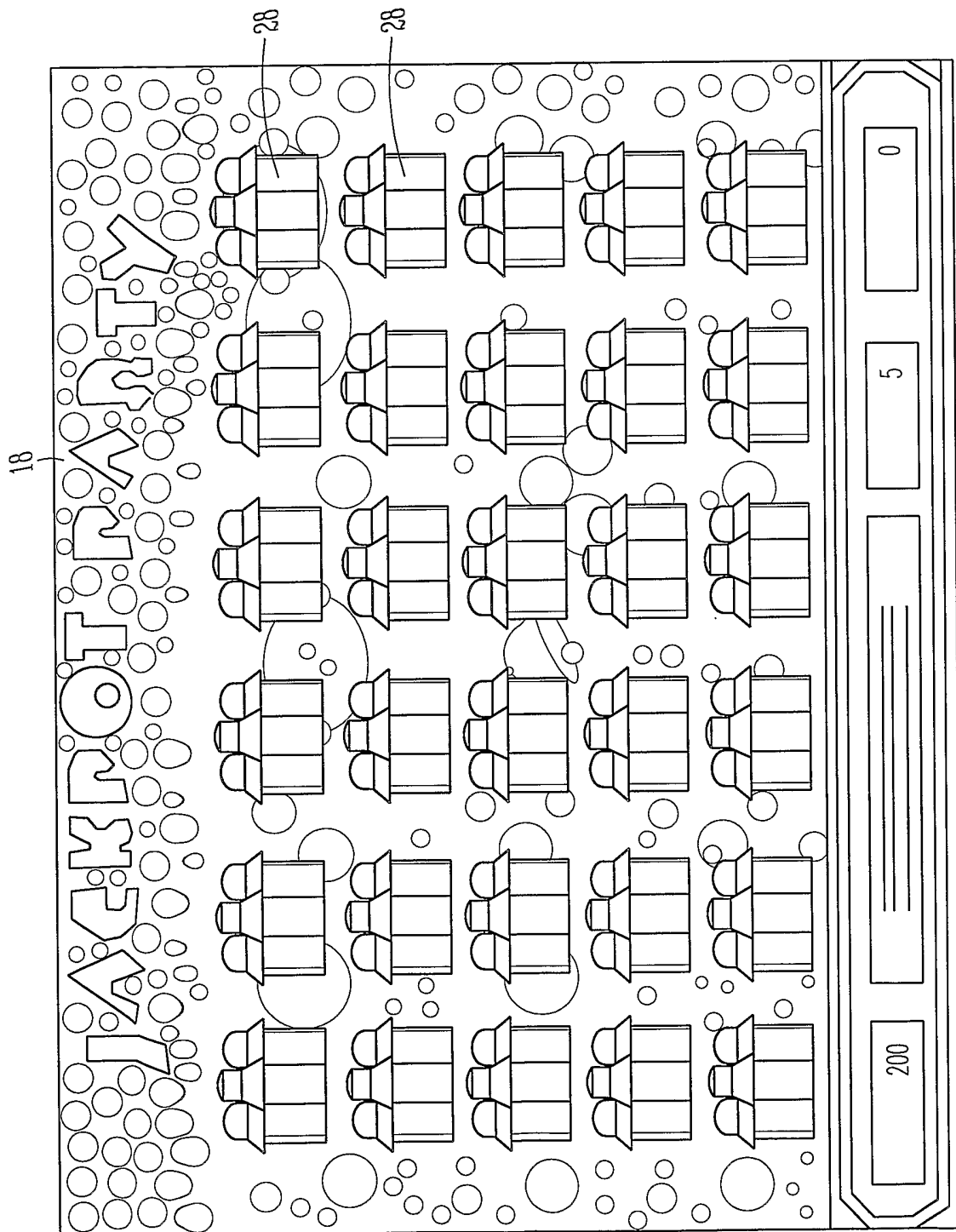

FIG. 7



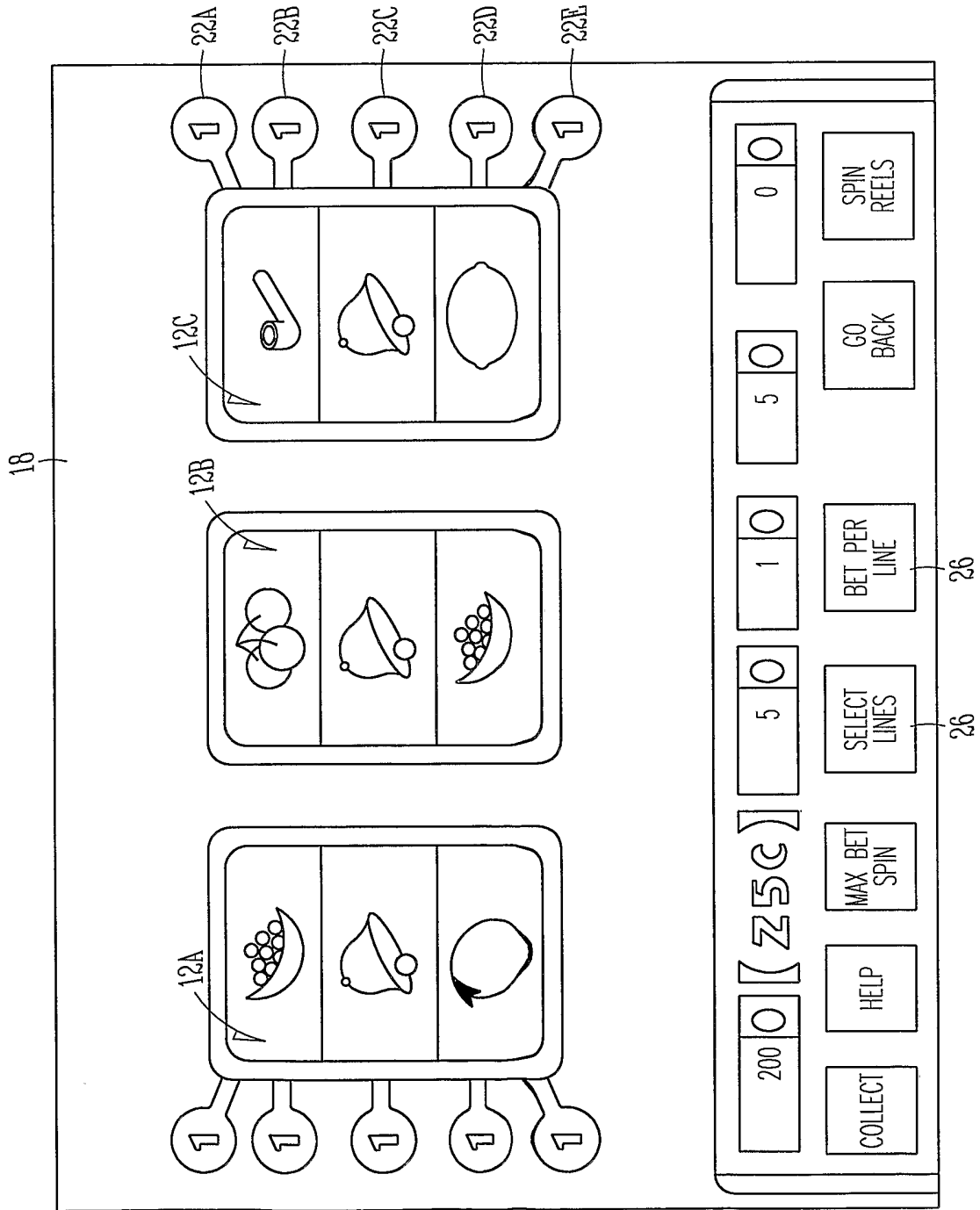

FIG. 8B



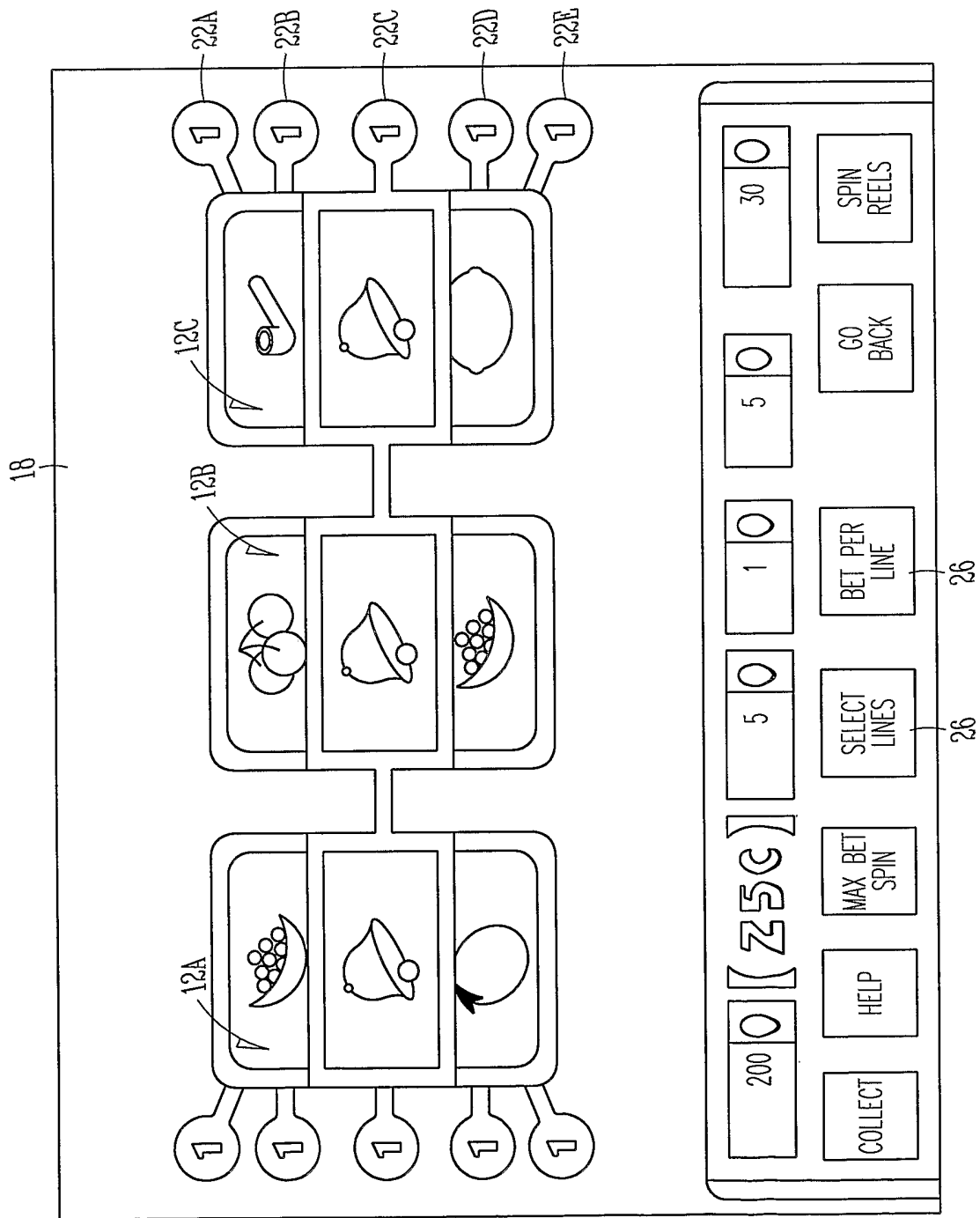

FIG. 8C





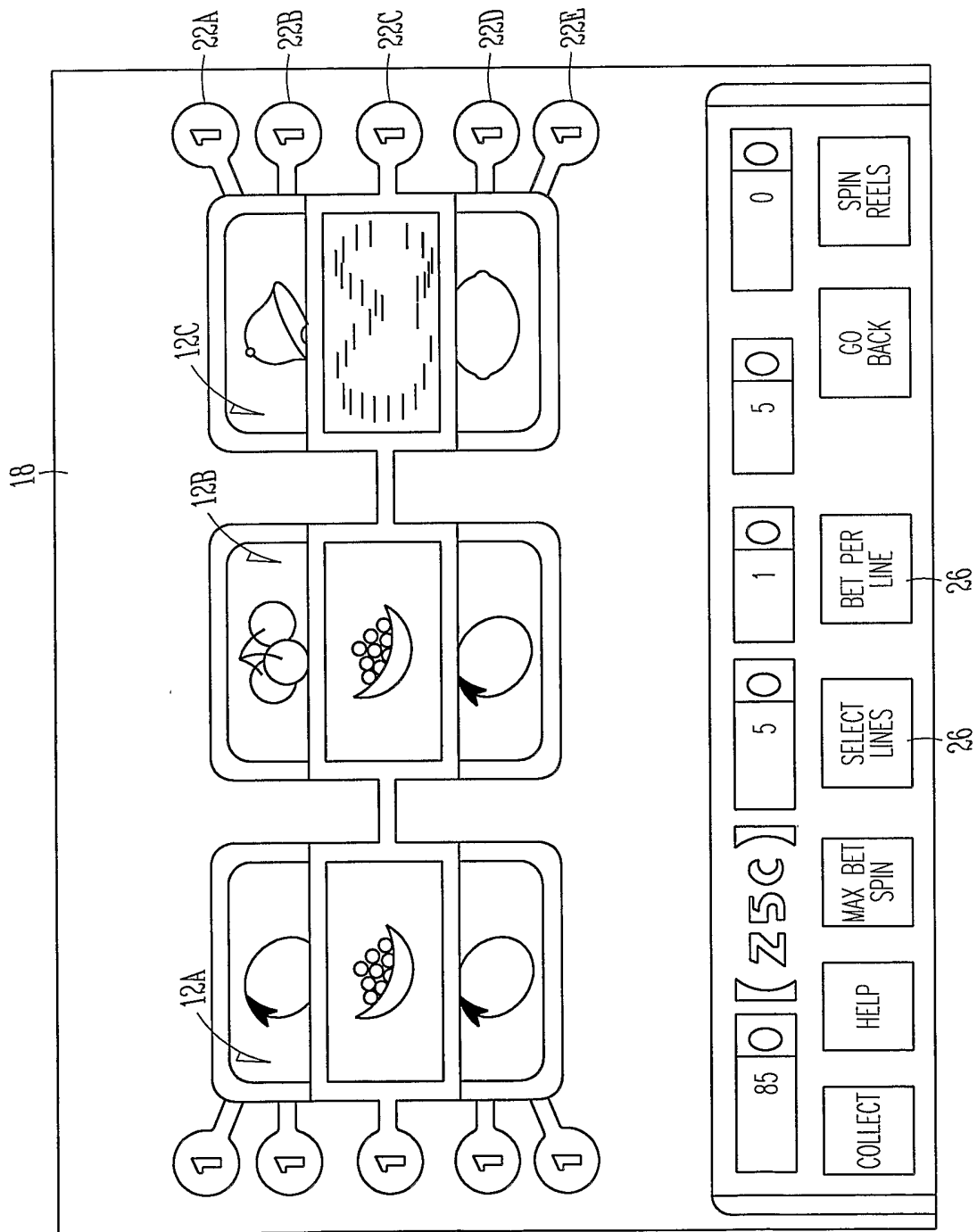
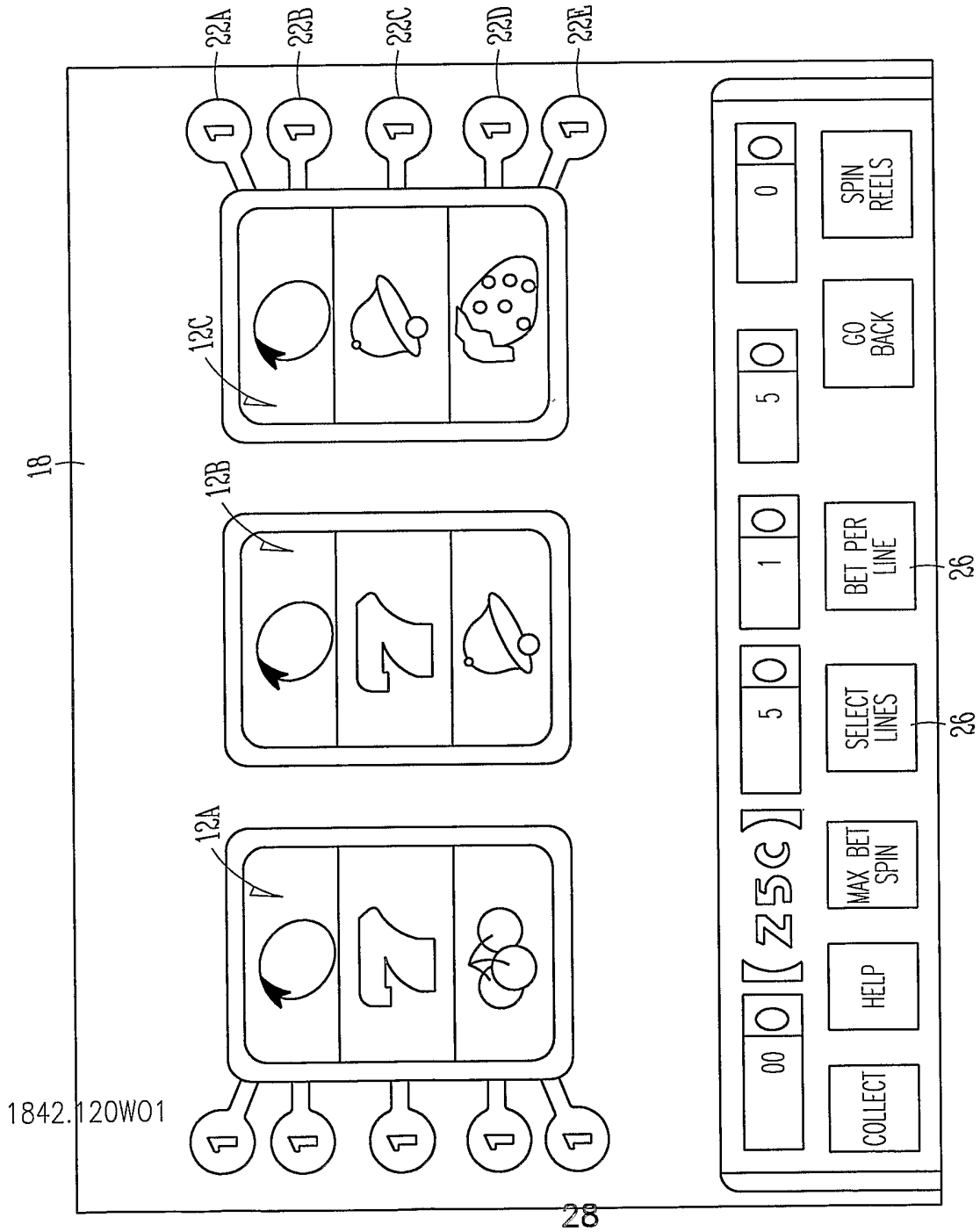

FIG. 9C



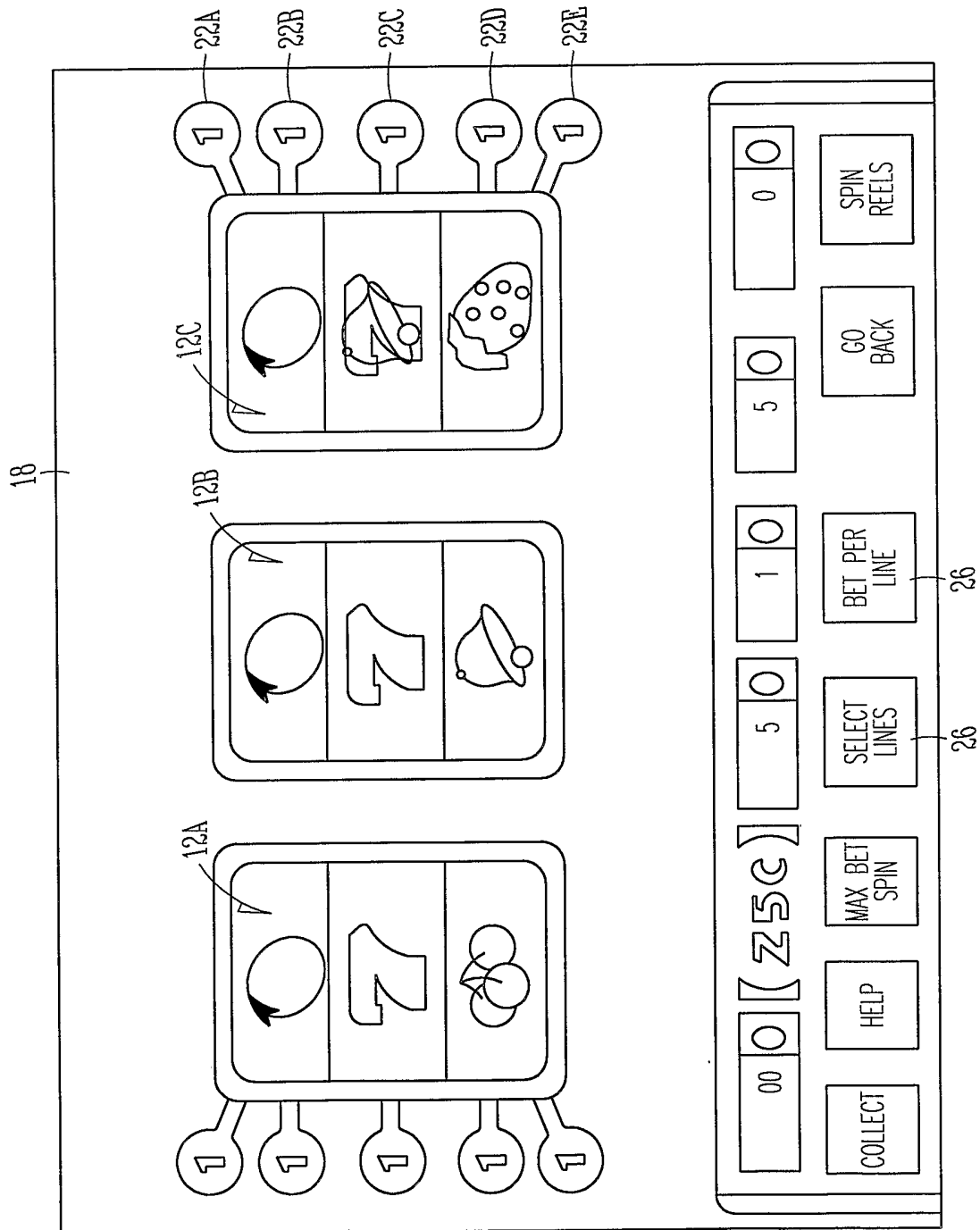

FIG. 10B

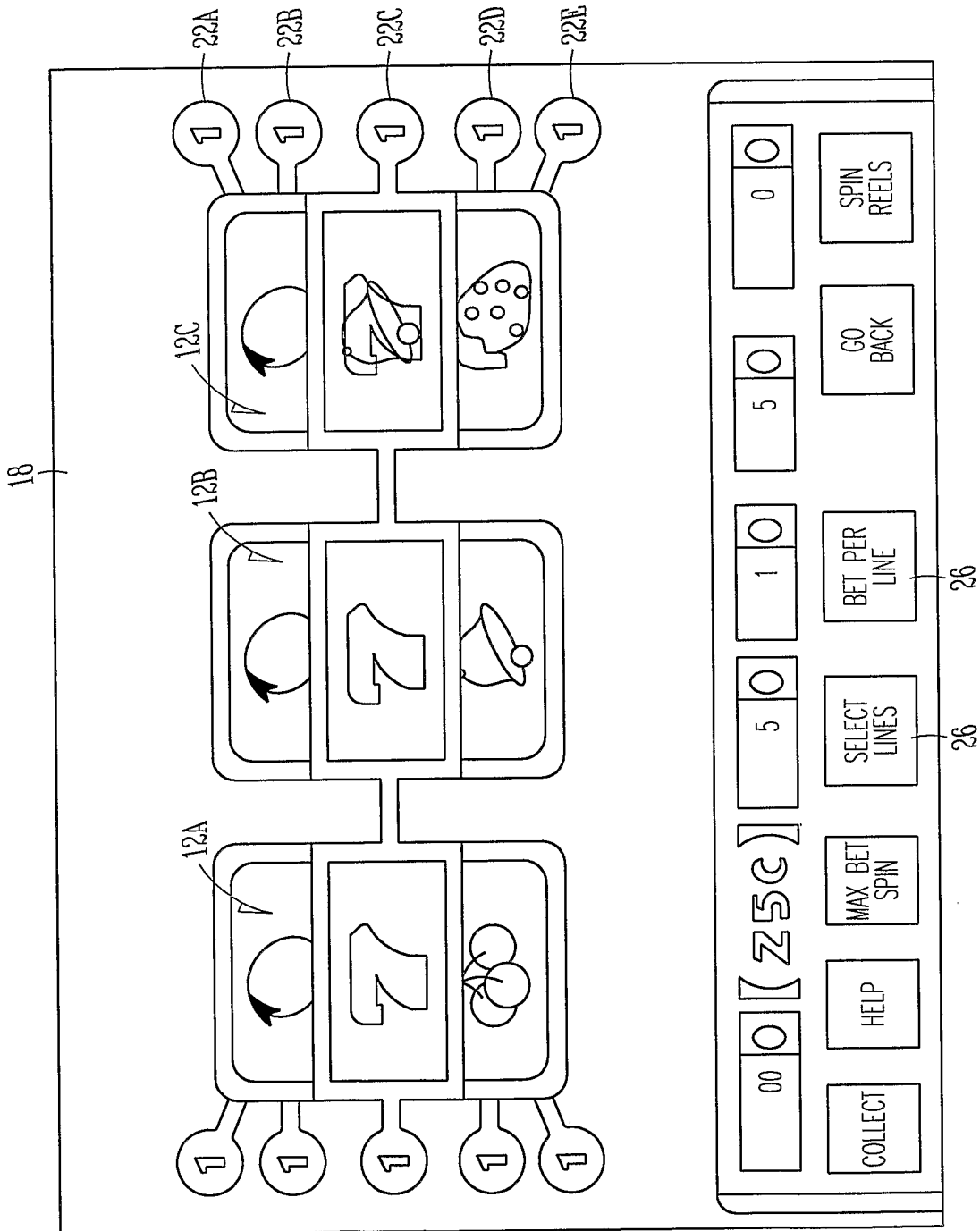

FIG. 10C





21/28

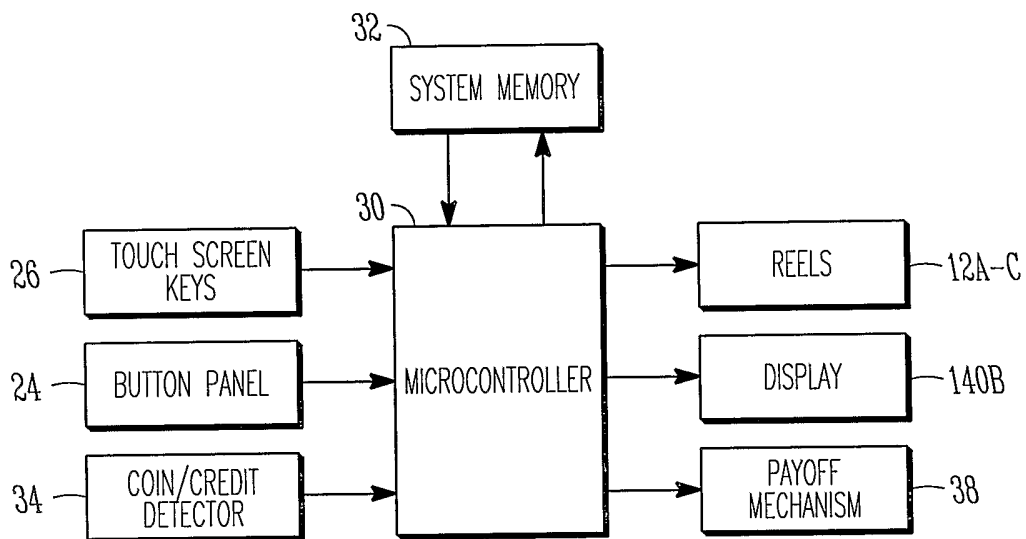

FIG. 12

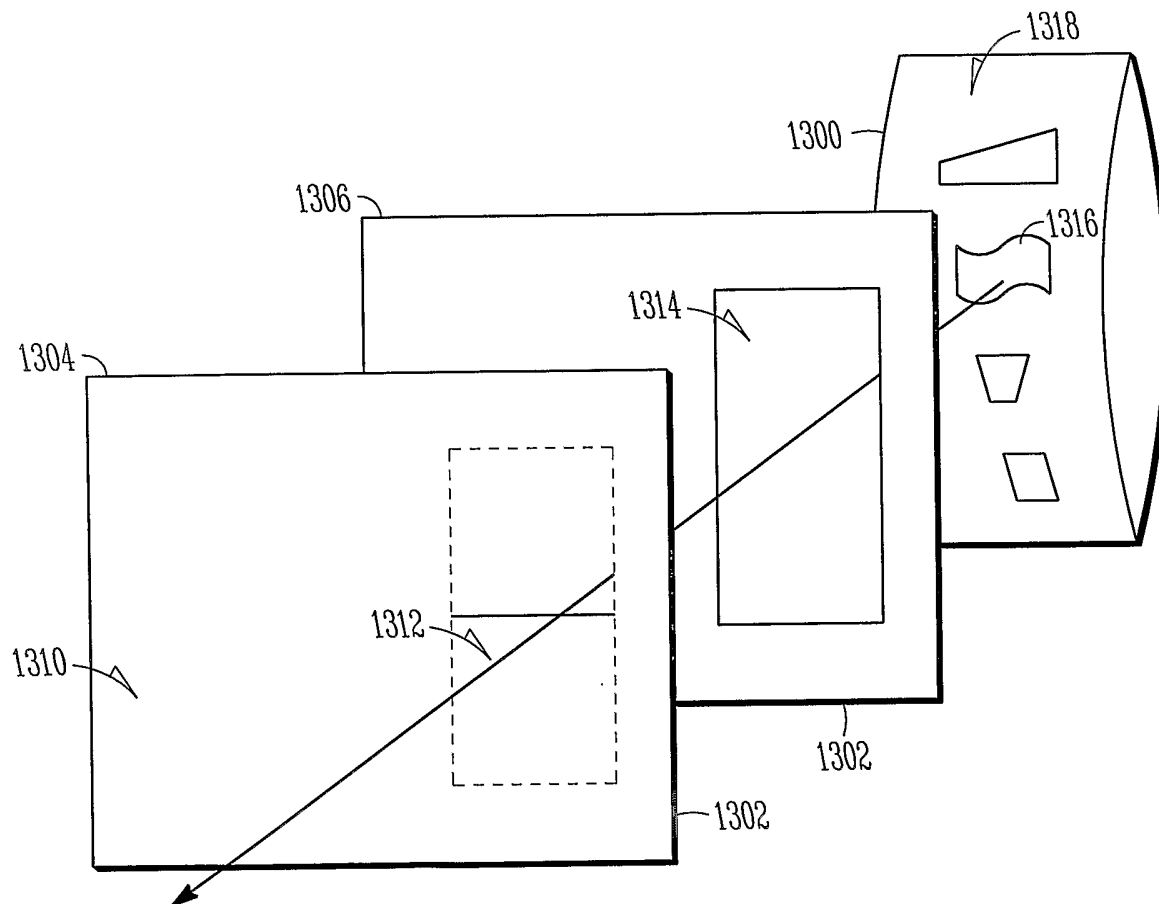

FIG. 13

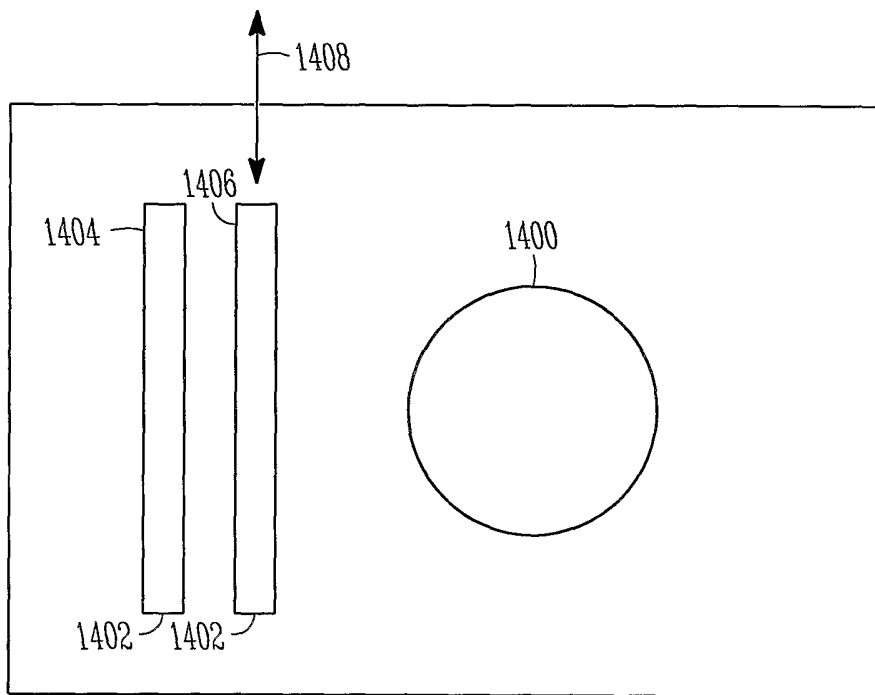

FIG. 14

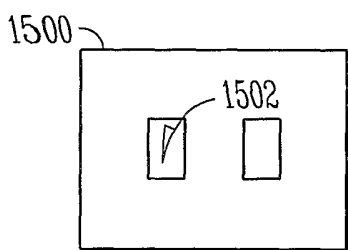

FIG. 15

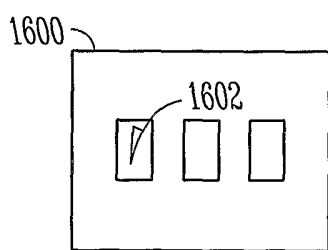

FIG. 16

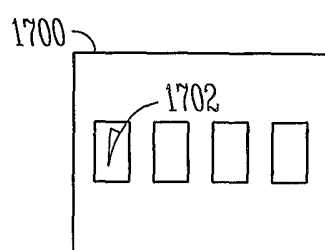

FIG. 17

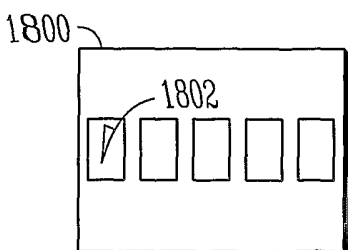

FIG. 18

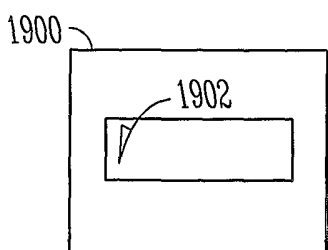

FIG. 19

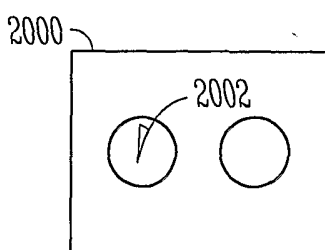

FIG. 20

23/28

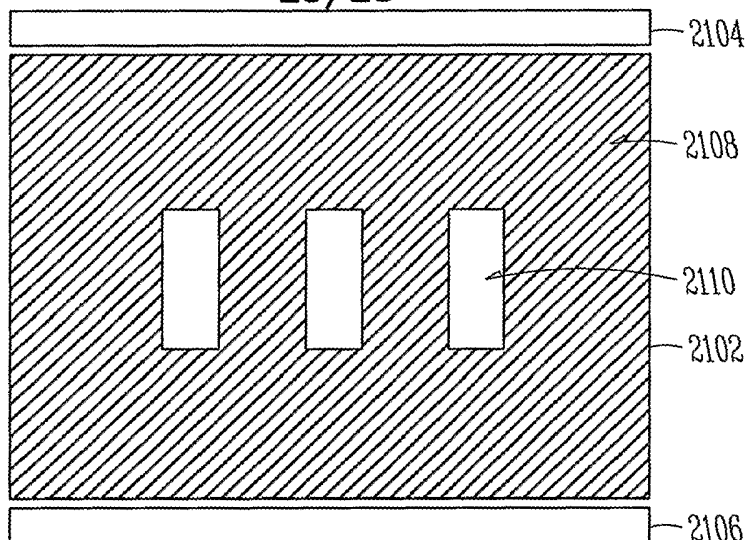

FIG. 21

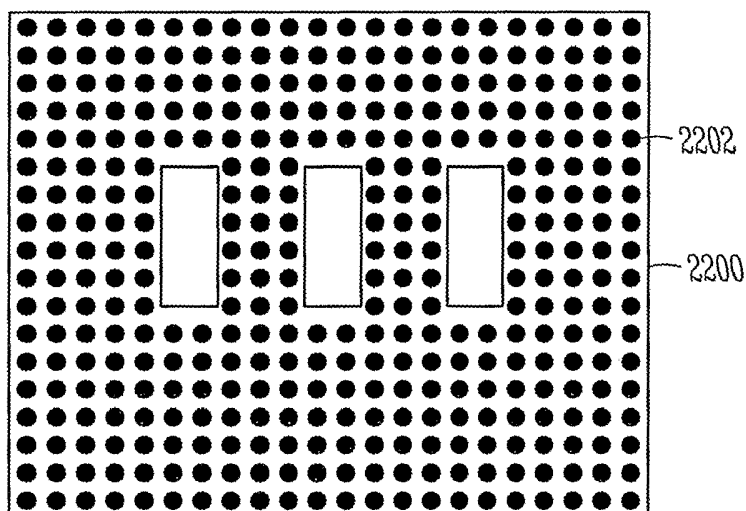

FIG. 22

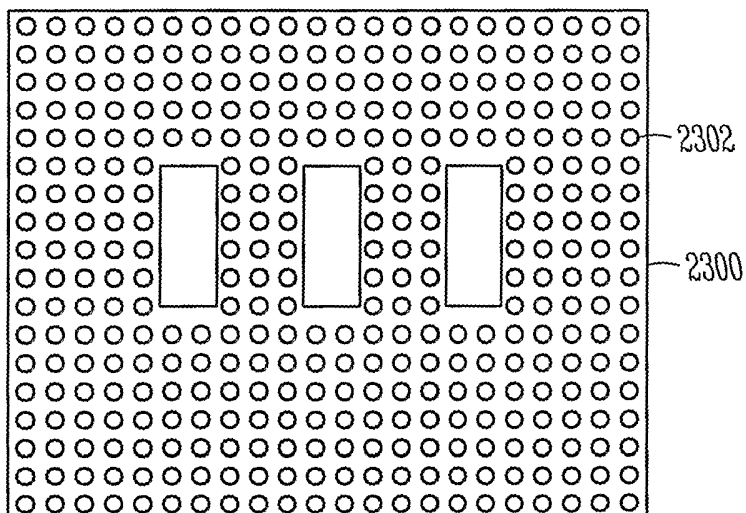

FIG. 23

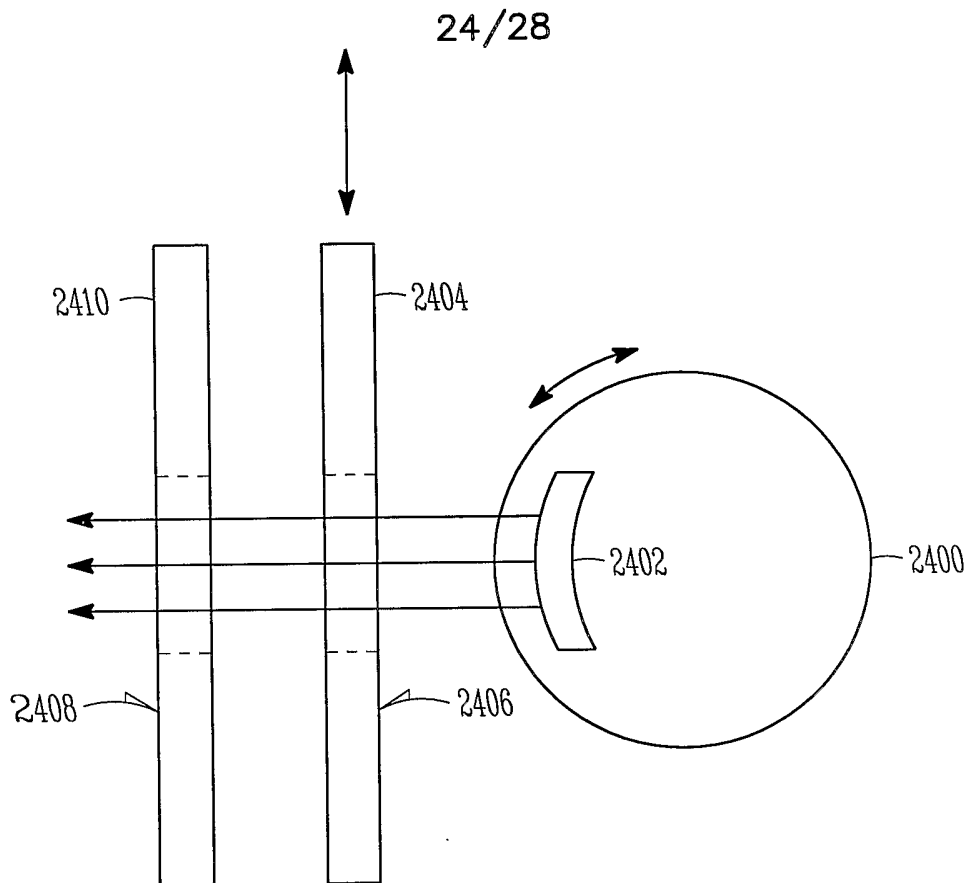

FIG. 24

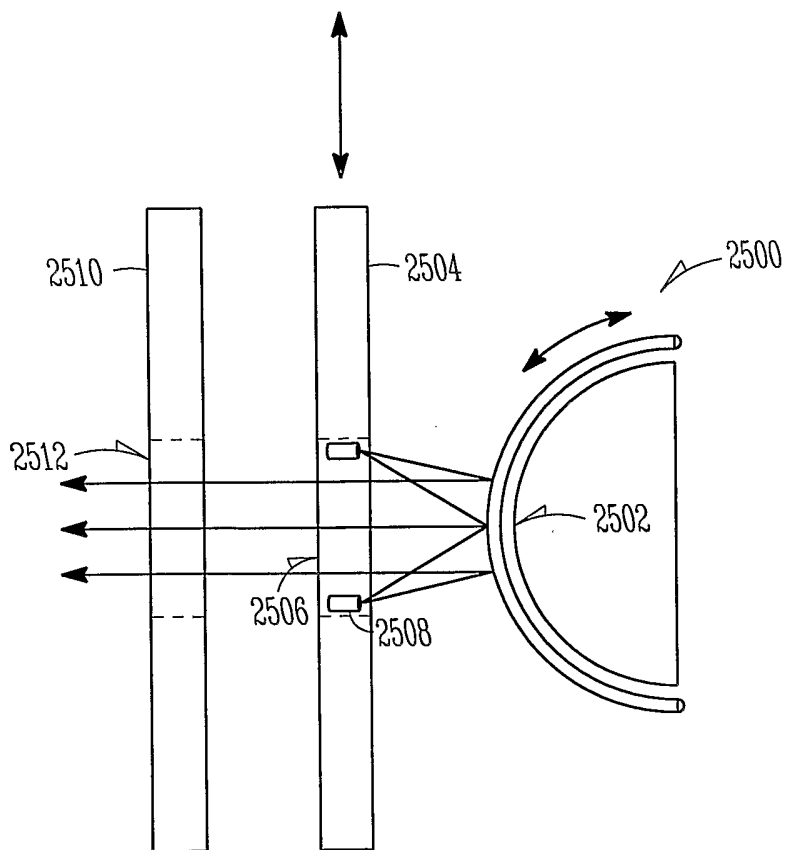

FIG. 25

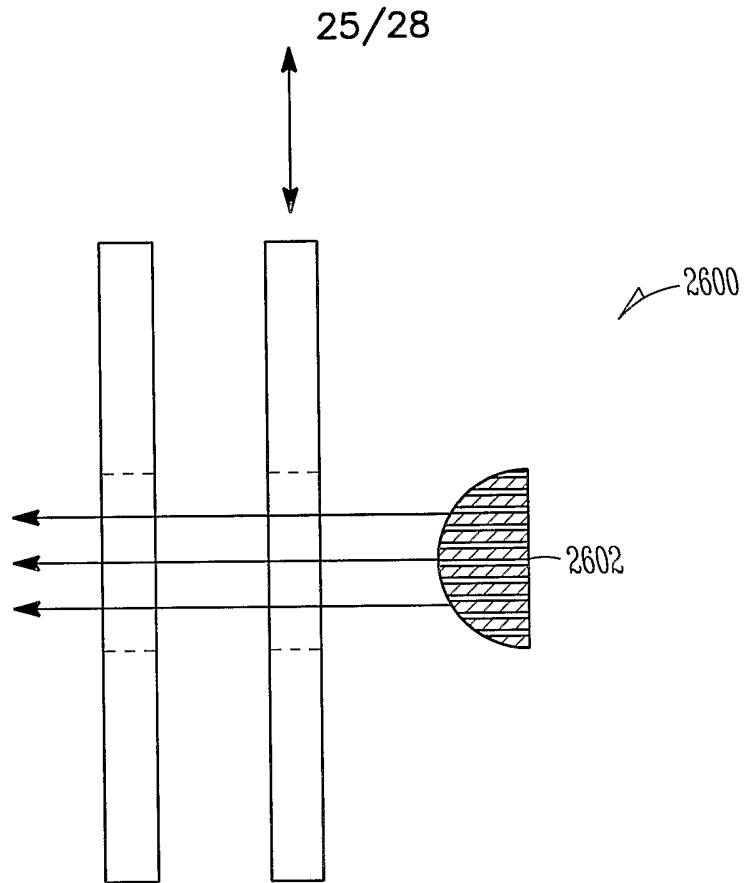

FIG. 26

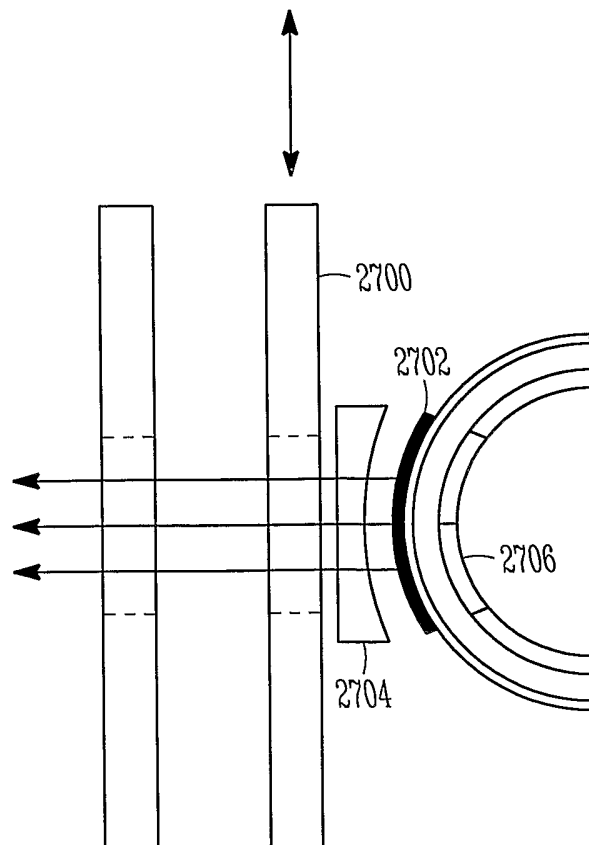

FIG. 27

26/28

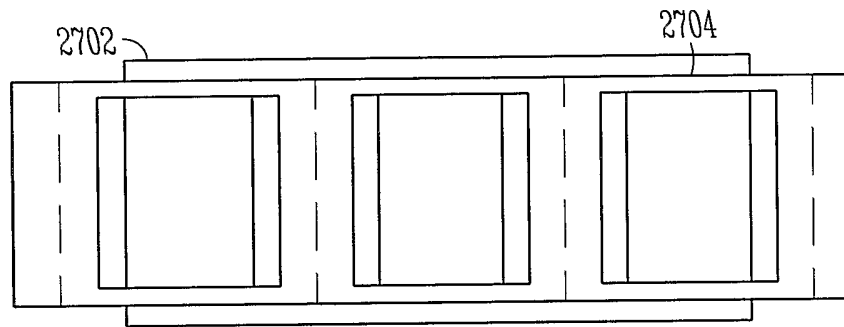

FIG. 28

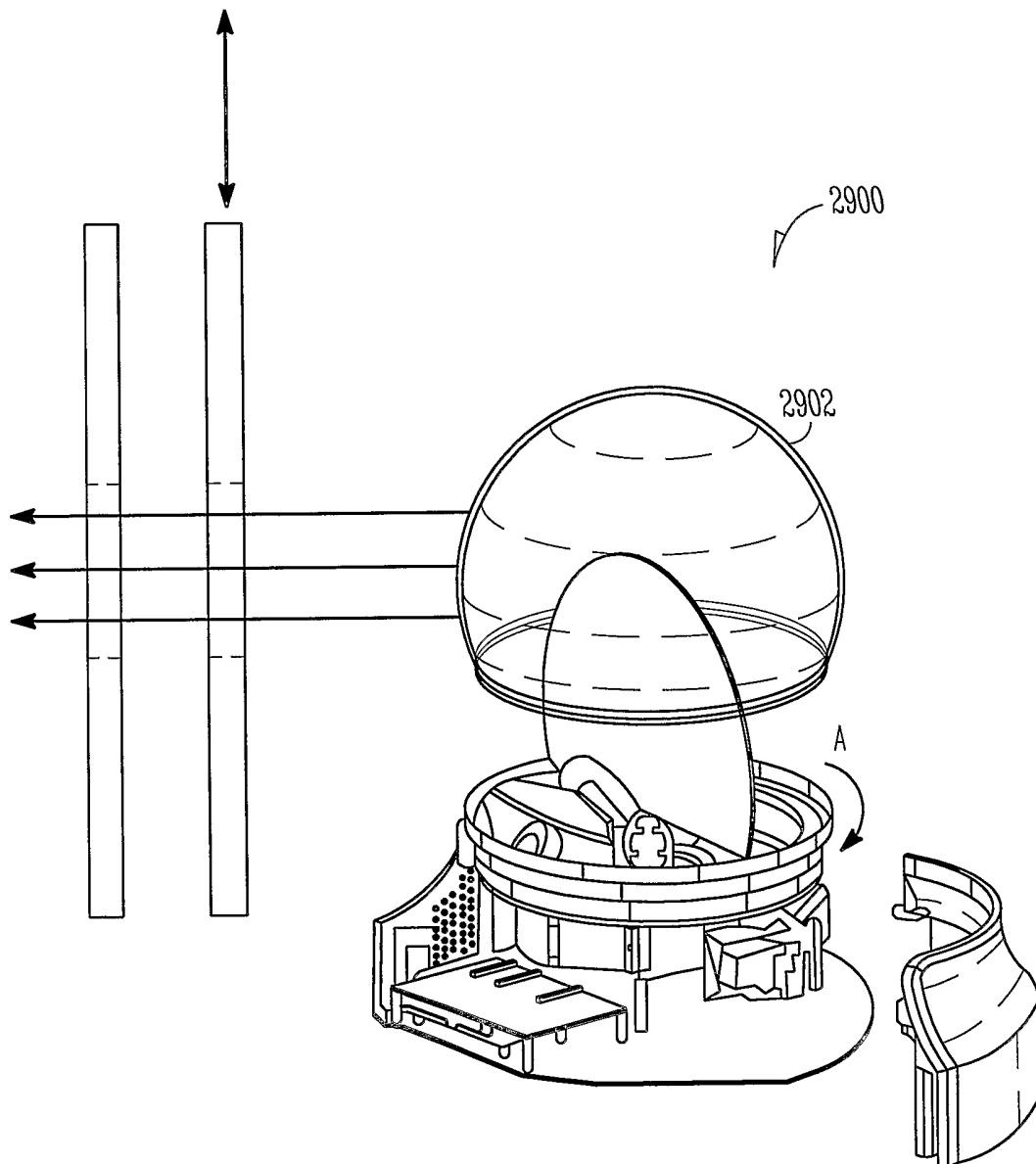
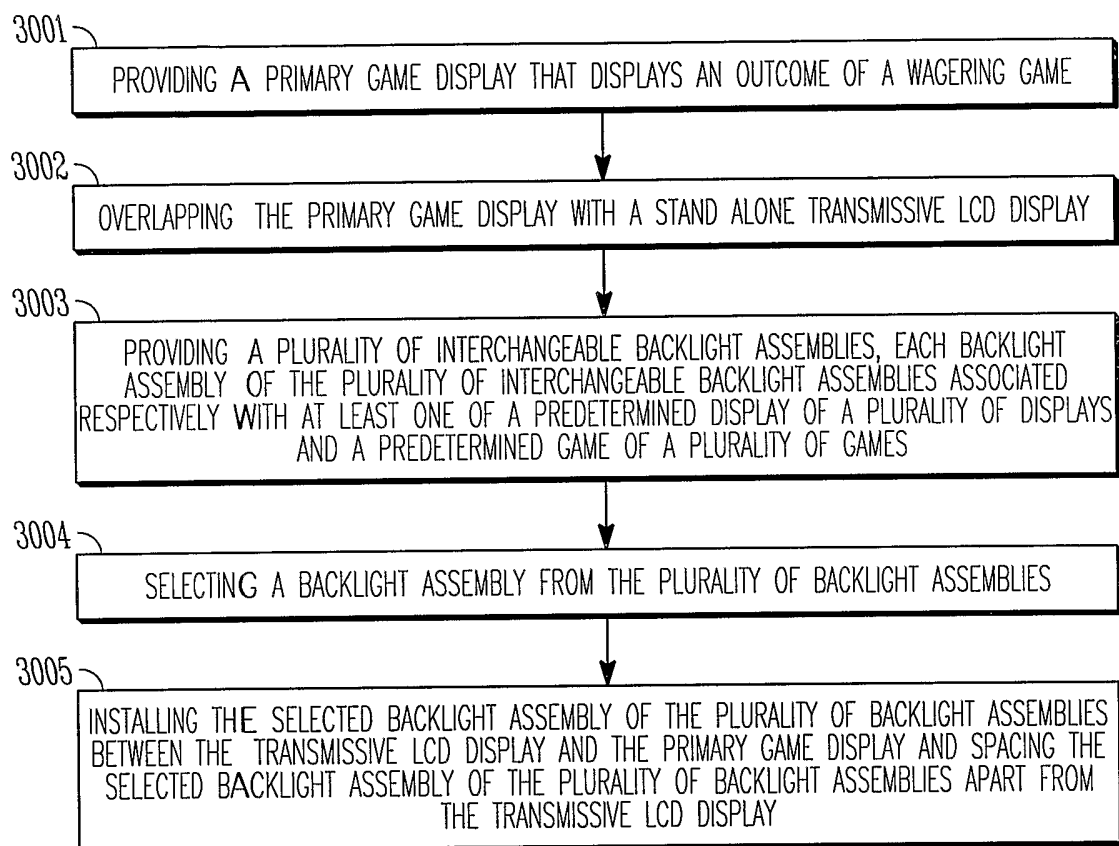
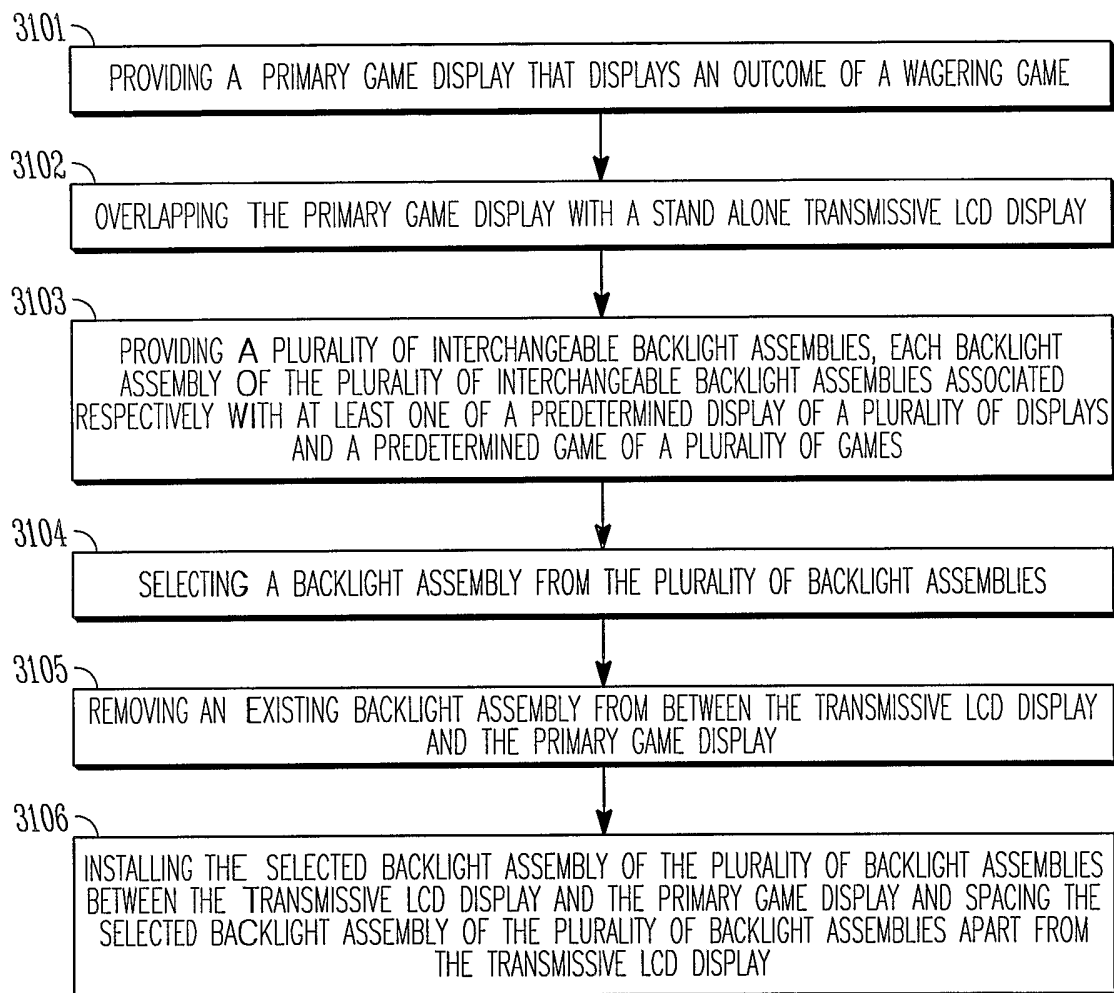

FIG. 29

27/28

*FIG. 30*

28/28

*FIG. 31*